

SERIES	DESCRIPTION	PAGE NO.
	Technical Tips.....	CE1-CE2
SUPER COILS		
	CC1/2" Solenoid Tubes	CE3-CE4
	CA.....5/8" Solenoid Tubes	CE5-CE6
	SW7L.....1/2" Solenoid Tube - Short.....	CE7- CE8
STANDARD COILS		
	DS.....1" Solenoid Tubes	CE9

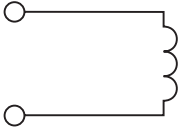

CV	Check Valves
SH	Shuttle Valves
LM	Load/Motor Controls
FC	Flow Controls
PC	Pressure Controls
LE	Logic Elements
DC	Directional Controls
MV	Manual Valves
SV	Solenoid Valves
PV	Proportional Valves
CE	Coils & Electronics
CB	Carpak Bodies
BC	Bodies & Cavities
TD	Technical Data

CV	Check Valves
SH	Shuttle Valves
LM	Load/Motor Controls
FC	Flow Controls
PC	Pressure Controls
LE	Logic Elements
DC	Directional Controls
MV	Manual Valves
SV	Solenoid Valves
PV	Proportional Valves
CE	Coils & Electronics
CB	Cartpak Bodies
BC	Bodies & Cavities
TD	Technical Data

INTRODUCTION

This technical tips section is designed to help familiarize you with the Parker line of Coils. In this section we highlight the features and discuss some of the available options.

We also use this section to present some common terminology related to coil and coil technology.

COMMON OPTIONS

Below are some of the common options to the Super Coil product offering.

Continuous Duty: Parker’s standard line of coils are rated for continuous duty operation. This means the coil can be left on continuously without fear of the magnet wire insulation breakdown, when used in standard climate conditions. The Super Coils are made of a high quality Class N magnet wire. This Class N rating signifies the internal wires are rated to 200°C (392°F).

Continuous duty does not mean the coil will have the same amount of power after hours of operation as it had at initial actuation. Coils do heat up during use. This internal heat rise increases the resistance of the coil and thus, decreases the current ($V = IR$). The performance curves presented on the solenoid valve pages are based on a coil at room temperature and 85% of voltage. Thus, when using a valve in continuous duty applications, you may need to derate the performance. In short, the continuous duty rating signifies that while the coil will get hot during use and resistance will increase, it will not generate enough heat to damage the coil.

Terminations: Parker offers a wide variety of coil terminations for all coils to meet the demands of your application. Over the years, the dual lead wire and dual spade offerings have been popular due to their ease of installation and availability. In the past few years, the demand for more secure termination connections has increased.

In addition, the integral connectors reduce cost and improve integrity by reducing the number of connections. As such, the DIN, and Integral Deutsch have increased in popularity.

If you do not find your desired coil termination in our catalog, contact your factory sales representative.

Current Types: Both direct current (DC) and alternating current (AC) versions are available for the Parker line of coils. The AC versions are essentially DC coils with a full wave rectifier integrally molded into the coil. The rectifiers are rated for voltage peaks up to 1000 volts maximum. For voltage transients greater than 1000 volts, a Harris Thyrector is recommended. The AC coils operate at 50/60 cycles (Hz). Since the AC versions are rectified DC coils, there is no inrush current like with “true” AC coils. It also means DC coils and AC coils are interchangeable.

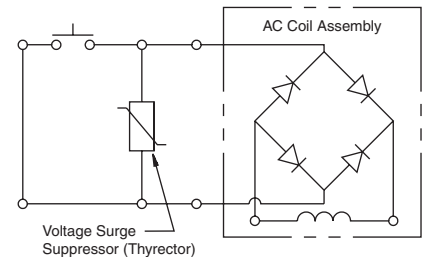

Voltages: Parker has a wide selection of coils available to meet your needs. Most coil terminations are available with our standard voltages of 12V and 24V in DC. Voltages 6V, 10V, 18V, 36V, 48V DC, 115 V, 120V and 440V AC may also be available for many termination types at a premium. Contact your Parker representative should your application call for voltages other than our standard offering.

Wattages: Parker offers a variety of coil wattages to meet the demands of your application. However, when using Parker’s ‘Winner’s Circle’ line, please note that all performance curves/values are based on using the higher watt coil. Selecting a lower watt coil could possibly de-rate the performance of the valve. Contact your Parker representative should your application call for wattages other than our standard offering.

Technical Tips

Diodes: The Parker Coils can be ordered with a diode molded internally. Parker Unicoils use a IN5062 diode. The Super Coils use a IN5627 diode. Diodes are sometimes used to protect sensitive, downstream electrical components from potential surges from the coil. By internally molding the diode into the coil, you can reduce the assembly time and cost associated with externally wiring a diode. One should be careful not to switch the polarity (“+” and “-” terminals), when wiring a coil with an internal diode. If these terminals are switched, the first time voltage is applied to the coil; the short circuit will destroy the diode and render the coil use-less.

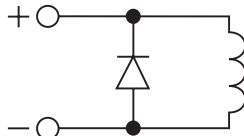

Parker coils with diodes have “+” and “-” molded near the termination outlet to help identify polarity.

Coils and Electronics

DIN Connectors: Parker does offer connectors for use with the DIN style coils. As shown below, the DIN connectors are available in both rectified and non-rectified forms. The cable gland versions can be ordered for type PG9 or PG11.

Cable Gland

Type	Non-Rectified	Rectified
PG9	710549-00	712126-01
PG11	710549-01	712126-00

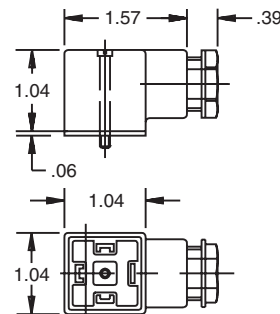

Conduit

Rectified
712704-00

Conduit

Non-Rectified
710549-02

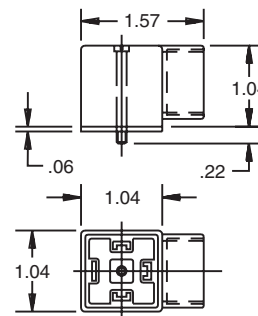
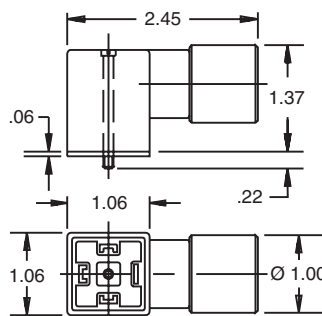

CV	Check Valves
SH	Shuttle Valves
LM	Load/Motor Controls
FC	Flow Controls
PC	Pressure Controls
LE	Logic Elements
DC	Directional Controls
MV	Manual Valves
SV	Solenoid Valves
PV	Proportional Valves
CE	Coils & Electronics
CB	Cartrpak Bodies
BC	Bodies & Cavities
TD	Technical Data

Features

- Integral Deutsch connector coil exceeds IP69K standards
- Integral Deutsch connector coil thermal shock dunk test rated
- Universal 50/60 Hz operation
- Waterproof coil hermetically sealed, requires no O-rings or waterproofing kits
- External plated steel flux-carrying band (unlike encapsulated band) enables coil to withstand severe thermal shocks without cracking
- Symmetrical coil can be reversed without affecting performance

Specifications

Coil Type	S Standard P Puissant
Nominal Wattage (See Ordering Information For Exact Wattage)	S 14 Watts P 19 Watts
Duty Cycle	Continuous @ 100% voltage
Magnetic Wire Insulation Class	'N' Rated at 200°C (392°F)
Temperature Range	-40°C to +200°C (-40°F to +392°F)
Temperature Rise At Nominal Voltage And Natural Ventilation	S 75°C (135°F) P 95°C (172°F)
Dielectric Strength Maximum Current Leakage (Amps)	.0005 In dry lab condition at 1000V AC for 30 seconds .001 After being immersed in 23°C (77°F) water with waterproof connector for 24 hours at 500V AC
Encapsulating Material	Glass filled rynite
Color Identification On The Terminal Boss	S Black Ring P Red Ring
Weight	0.20 kg (0.44 lbs.)

AC Coil Assembly

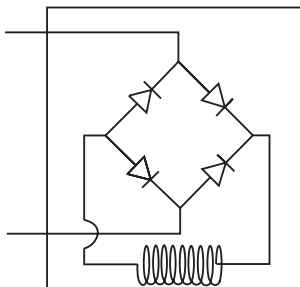

Ordering Information

CC	<input type="checkbox"/>	<input type="checkbox"/>	<input type="checkbox"/>
Super Coil 1/2" I.D.	Wattage	Voltage	Termination

Code	Wattage
S	Standard
P	Puissant

Code	Voltage	Watts		Amps		Ohms**	
		S	P	S	P	S	P
012*	12 VDC	14	19	1.15	1.58	10.43	7.58
024*	24 VDC	14	19	0.58	0.79	41.74	30.30
115*	115 VAC	16	19	0.17	0.20	680	576

*Standard Voltages

**Resistance ±10% at 68°F

Code	Termination
*C	Double Lead Wire with Conduit Connector (AC Only)
*D	DIN 43650 (AC or DC, Supplied without DIN Connector)
*H	Integral Deutsch
*HSN	Integral Deutsch with Anti-vibration ring
*HSZN	Integral Deutsch with Anti-vibration ring and Zener Diode
*L	Double Lead (DC Only)
*S	Double Spade (DC Only)

*UL listed 12/24 VDC only.

Note: Additional voltages and other terminals are available. Some coils are UL approved. For details please consult factory.

DIN Female Mating Connector: See page CE2

Deutsch Mating Connector: # DT06-2S

Terminal Styles and Dimensions

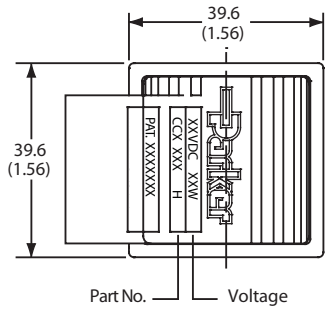
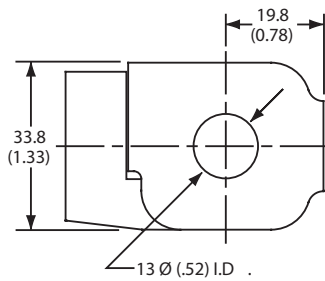

<p>S - Double Spade</p>	<p>L - Double Lead 18 gauge 457mm 18" long black color</p>
<p>HSN - Integral Deutsch with Anti-Vibration Ring</p> <p>HSZN - Integral Deutsch with Anti-Vibration Ring and Zenner Diode</p> <p>H - Integral Deutsch DT04 - 2P - EP04 (+ and - metered)</p>	<p>D - DIN 43650 (ground wire on AC only)</p>

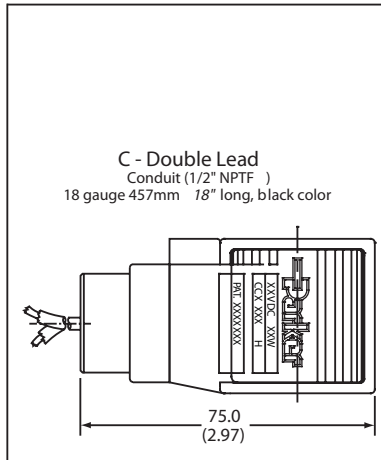

NOTES:

1. The standard A.C. coil includes a molded-in full wave rectifier rated for 800 peak reverse voltage.
2. All P Puissant (high wattage) coils use a red ring as an indication marker on the terminal boss.



CV
Check Valves
SH
Shuttle Valves
LM
Load/Motor Controls
FC
Flow Controls
PC
Pressure Controls
LE
Logic Elements
DC
Directional Controls
MV
Manual Valves
SV
Solenoid Valves
PV
Proportional Valves
CE
Coils & Electronics
CB
Cartrpak Bodies
BC
Bodies & Cavities
TD
Technical Data