

# RV8-10 - Relief Valve

Poppet, direct acting, differential area  
76 L/min (20 USgpm) • 350 bar (5000 psi)

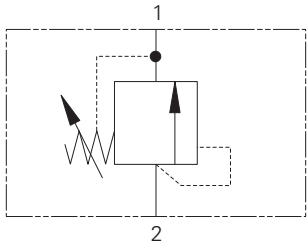

## Operation

This valve remains closed from port 2 to 1 until the predetermined setting has been reached at port 2.

The pressure acts on the differential area between the seat and the seal diameter on the poppet.

## Features

Hardened and ground working parts. Low leakage poppet design. High flow rate for a compact cartridge.

## Sectional View

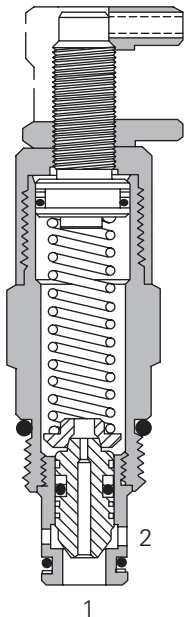

## Performance Data

### Ratings and Specifications

Performance data is typical with fluid at 21,8 cSt (105 SUS) and 49° C (120° F)

Typical application pressure (all ports)	350 bar (5000 psi)
Cartridge fatigue pressure (infinite life)	350 bar (5000 psi)
Rated flow	76 L/min (20 USgpm)
Internal leakage	0.3 mL/min (5 drops/min) @ 85% of Pressure Setting
Cavity	C-10-2
Standard housing materials	Aluminum or steel
Temperature range	-40° to 120°C (-40° to 248°F)
Fluids	All general purpose hydraulic fluids such as: MIL-H-5606, SAE 10, SAE 20, etc.
Filtration	Cleanliness Code 18/16/13
Weight cartridge only	0,22 kg (0.48 lbs)
Seal kits – RV8	565803 Buna-N 566086 Viton®
– RV8A	565806 Buna-N 889627 Viton®

Viton is a registered trademark of E.I. DuPont

## Description

This is a fast, direct acting differential area screw-in cartridge relief valve. The valve is ideal for the protection against shock pressures that can damage actuators.

## Pressure Override Curves

Cartridge only  
Tank pressure = 0

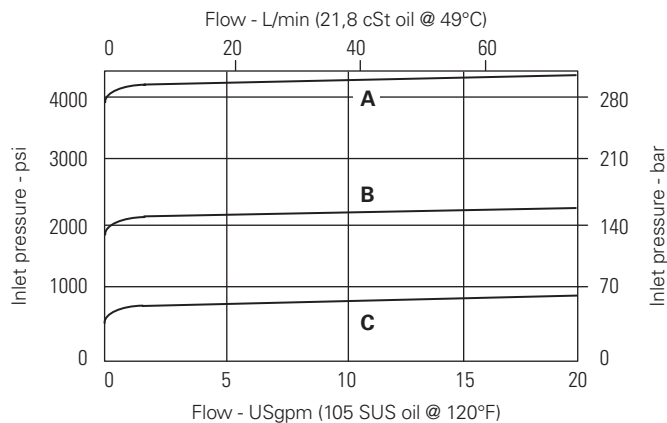

# RV8-10 - Relief Valve

Poppet, direct acting, differential area

76 L/min (20 USgpm) • 350 bar (5000 psi)

## Model Code

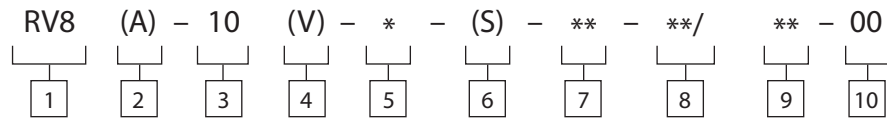

**1** Function  
RV8 - Relief valve

**2** Cage Seals  
Blank - Single back-up ring as shown  
A - 1/2 thickness back-up ring on each side of o-ring (for cross port relief applications)

**3** Size  
10 - 10 size

**4** Seal Material  
Blank - Buna-N  
V - Viton®

**5** Adjustment  
C - Cap  
F - Factory set  
I - Internal  
K - Knob  
S - Screw

**6** Valve Housing Material  
Blank - Aluminum  
S - Steel

**7** Port Size  
0 - Cartridge only

Code	Port Size	Housing Number	Aluminum Light duty	Aluminum Fatigue rated	Steel Fatigue rated
3B	3/8" BSPP	02-175462	-	-	-
2G	1/4" BSPP	-	-	876702	02-175102
3G	3/8" BSPP	-	-	876703	02-175103
6H	SAE 6	-	-	876700	-
8H	SAE 8	-	-	876701	-
6T	SAE 6	566151	-	-	02-175100
8T	SAE 8	-	-	-	02-175101

See section J for housing.

**8** Cracking Pressure Range  
Note: Code based on pressure in psi.  
4 - 3,45-30 bar (50-450 psi)  
12 - 7-86 bar (100-1250 psi)  
25 - 17-175 bar (250-2500 psi)  
50 - 38-350 bar (550-5000 psi)

**9** Setting Pressure  
Within ranges in **8**  
Blank - Normal factory setting at approximate mid-range. User requested settings in 3,45 bar (50 psi) steps, Coded as in the following examples:  
10 - 70 bar (1000 psi)  
10.5 - 72,4 bar (1050 psi)

**10** Special Features  
00 - None  
(Only required if valve has special features, omitted if "00.")  
SS - 316 Stainless Steel external components



**WARNING**  
Aluminum housings can be used for pressures up to 210 bar (3000 psi). Steel housings must be used for operating pressures above 210 bar (3000 psi).

Torque cartridge in housing  
A - 47-54 Nm (35-40 ft. lbs)  
S - 68-75 Nm (50-55 ft. lbs)

## Dimensions

mm (inch)

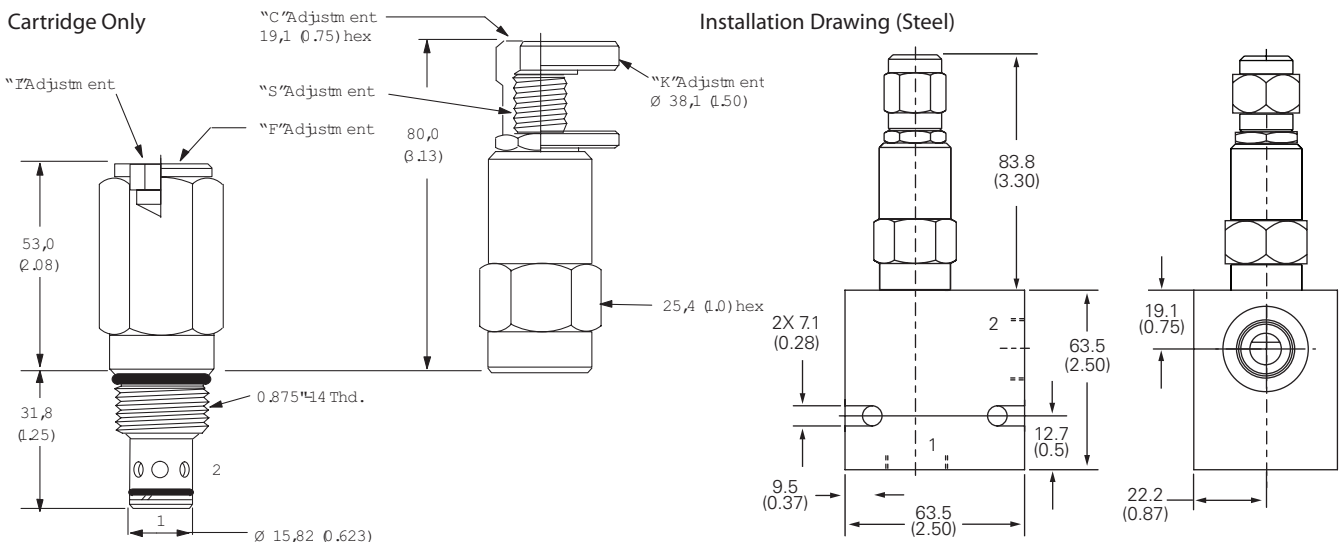

Where measurements are critical request certified drawings. We reserve the right to change specifications without notice.