

PRV2-10 - Pressure reducing/relieving valve

Spool, pilot operated
38 L/min (10 USgpm) • 240 bar (3500 psi)

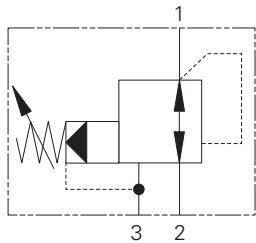

Operation

This valve is normally open allowing inlet oil to pass to the regulated line until the outlet (regulated) pressure exceeds the setting of the pilot section. When this setting is achieved a pilot flow occurs, causing a pressure imbalance across the main spool, which then moves throttling the inlet flow

and preventing any further pressure rise in the regulated line. If any external force causes the regulated pressure to rise more than 5-10% above the setting, the main spool moves back further, opening the regulated port to the tank line, thus working as a relief valve.

Features

Cartridge construction with hardened, ground and honed working parts giving smooth, stable operation over all pressure ranges.

Sectional view

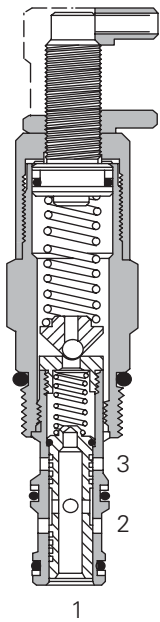

Performance data

Ratings and specifications

Performance data is typical with fluid at 21,8 cSt (105 SUS) and 49° C (120° F)

Typical application pressure (all ports)	240 bar (3500 psi)
Cartridge fatigue pressure (infinite life)	210 bar (3000 psi)
Rated flow	38 L/min (10 USgpm)
Cavity	C-10-3
Standard housing materials	Aluminum or steel
Temperature range	-40° to 120°C (-40° to 248°F)
Fluids	All general purpose hydraulic fluids such as: MIL-H-5606, SAE 10, SAE 20, etc.
Filtration	Cleanliness Code 18/16/13
Weight cartridge only	0,24 kg (0.54 lbs)
Seal kits	565804 Buna-N 889599 Viton®

Viton is a registered trademark of E.I. DuPont

Description

This is a pilot operated screw in cartridge pressure reducing / relieving valve. The valve maintains a constant outlet pressure in hydraulic sub-systems regardless of fluctuations in the primary system. In addition to this it will act as a relief valve if the pressure in the sub-system rises higher than the setting of the valve directing excess fluid to tank.

Pressure override curves

Cartridge only

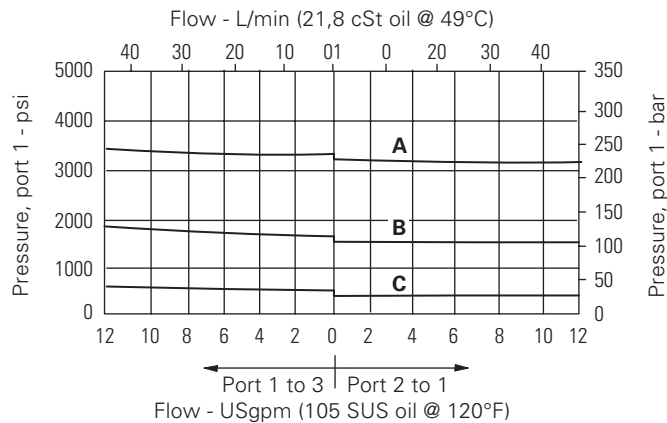

- A - 35 spring
- B - 20 spring
- C - 3 spring

Where measurements are critical request certified drawings. We reserve the right to change specifications without notice.

PRV2-10 - Pressure reducing/relieving valve

Spool, pilot operated
38 L/min (10 USgpm) • 240 bar (3500 psi)

Model code

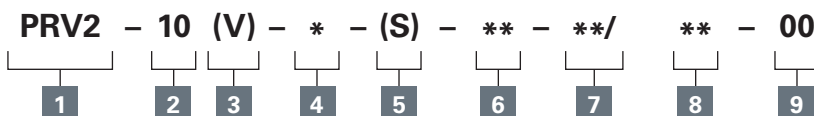

1 Function

PRV2 - Pressure reducing/relieving valve

2 Size

10 - 10 size

3 Seal material

Blank - Buna-N
V - Viton®

4 Adjustment

C - Cap
F - Factory set
I - Internal
K - Knob
S - Screw

5 Valve housing material

Blank - Aluminum
S - Steel

6 Port size

0 - Cartridge only

Code	Port size	Housing number		
		Aluminum light duty	Aluminum fatigue rated	Steel fatigue rated
3B	3/8" BSPP	02-173358	-	-
2G	1/4" BSPP	-	876705	02-175127
3G	3/8" BSPP	-	876714	02-175128
6H	SAE 6	-	876704	-
8H	SAE 8	-	876711	-
6T	SAE 6	566162	-	02-175124
8T	SAE 8	-	-	02-175125

See section J for housing.

7 Cracking pressure range

Note: Code based on pressure in psi.

3 - 3,5-20 bar (50-300 psi)
20 - 7-140 bar (100-2000 psi)
35 - 17-240 bar (250-3500 psi)

8 Factory set reduced pressure

Within ranges in **7**

Blank - Normal factory setting at approximate mid-range. User requested settings in 3,45 bar (50 psi) steps, Coded as in the following examples:

10 - 70 bar (1000 psi)
10.5 - 72,4 bar (1050 psi)

9 Special features

00 - None (Only required if valve has special features, omitted if "00.")
SS - 316 Stainless Steel external components

Dimensions

mm (inch)
Cartridge only

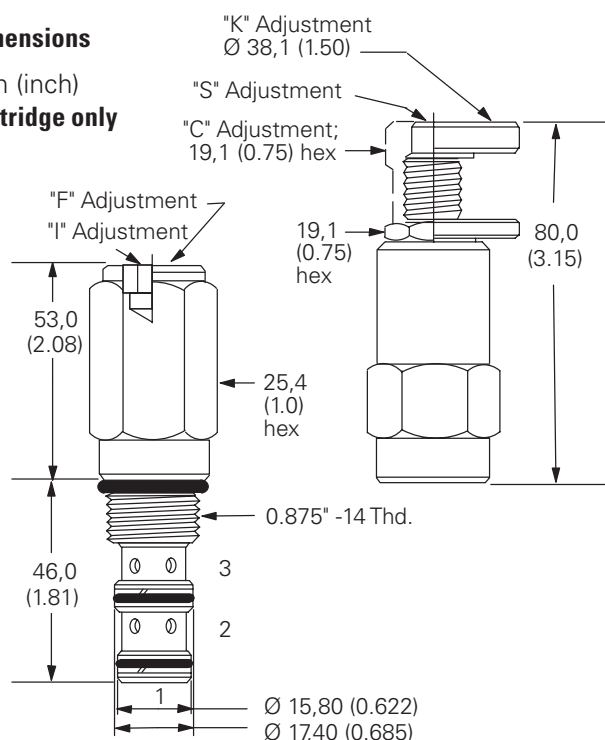

Installation drawing (Steel)

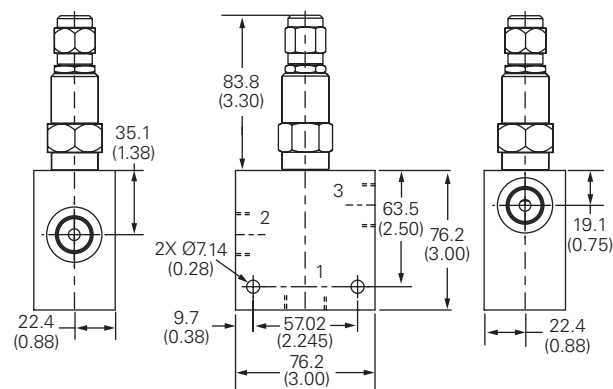

Torque cartridge in housing
A - 47-54 Nm (35-40 ft. lbs)
S - 68-75 Nm (50-55 ft. lbs)

Warning

Aluminum housings can be used for pressures up to 210 bar (3000 psi). Steel housings must be used for operating pressures above 210 bar (3000 psi).

Where measurements are critical request certified drawings. We reserve the right to change specifications without notice.