

PFRD/S-16 - Priority flow control

Spool type, load-sensing
150 L/min (40 USgpm) • 280 bar (4000 psi)

Dynamic signal (PFRD)

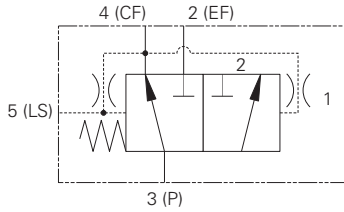

Static signal (PFRS)

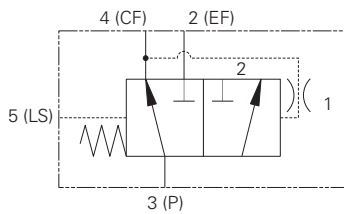

Sectional view

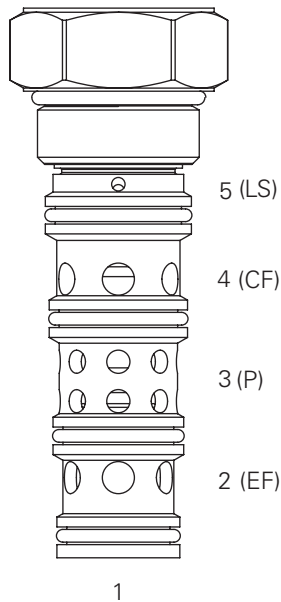

Note: Port 1 unused, port should be plugged.

Description

This is a load sense priority flow regulator designed to provide a controlled pressure compensated flow on demand. The valve is ideal for steering or accumulator charging circuits.

Operation

This valve is used in the flow control mode. Pump flow from the valve inlet port 3 is delivered first to port 4 at a fixed rate; excess flow is bypassed to port 2. The valve maintains the controlled flow to 4 regardless of inlet pressure change or load pressure changes at 2 or 4. This valve is typically used with open loop load sense systems in steering and braking circuits. The static type is used for less difficult applications where response or circuit stability is not a problem. The dynamic type is used for difficult applications where response or circuit

stability are critical. The load sense line connected to port 5 should not exceed 2 Meters (6 Feet) in length. Overpressure protection for the circuits connected to ports 2 and 4 must be provided by external relief valves. The control pressure is determined by assuring adequate inlet pressure to the steering unit and must be matched to the steering unit's required flow. The control pressure must be supplied to the valve as a minimum inlet pressure. The pressure at port 4 can vary by 10% when the load at the excess flow port 2 varies from 0 to maximum pressure.

Features

Hardened and ground working parts to limit leakage and extend service life. Robust design with a 280 bar max pressure rating.

Performance data

Ratings and specifications

Performance data is typical with fluid at 21,8 cSt (105 SUS) and 49°C (120°F)

Typical application pressure (all ports)	280 bar (4000 psi)
Cartridge fatigue pressure (infinite life)	280 bar (4000 psi)
Rated inlet flow	150 L/min (40 USgpm)
Temperature range	-40° to 120°C (-40° to 248°F)
Cavity	C-16-5S
Fluids	All general purpose hydraulic fluids such as: MIL-H-5606, SAE 10, SAE 20 etc.
Filtration	Cleanliness code 18/16/13
Standard housing material	Aluminum or Steel
Weight cartridge only	0,47 kg (1.05 lbs)
Seal kit	202915-922
Internal leakage	164cc/min (10 in 3/min) @ 3000 PSID
Recommended L/S orifice	0.036" (not included in valve)

Pressure drop

Cartridge only

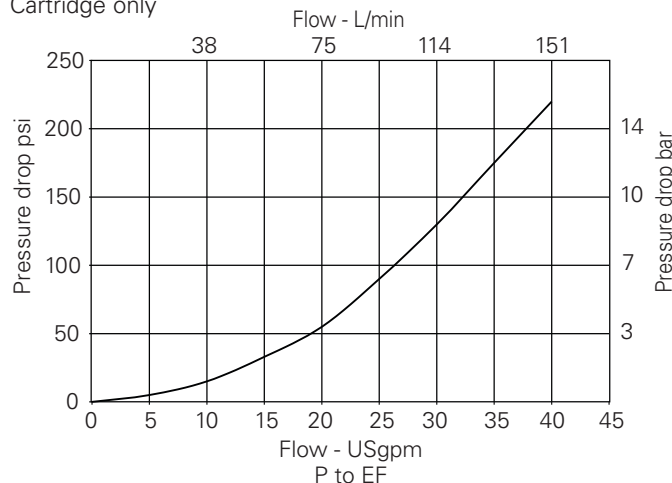

Notes: Minimum inlet flow should not be less than 1/4 of maximum inlet flow. Minimum pressure drop is determined by control pressure.

Where measurements are critical request certified drawings. We reserve the right to change specifications without notice.

PFRD/S-16 - Priority flow control

Spool type, load-sensing
150 L/min (40 USgpm) • 280 bar (4000 psi)

Model code



1 Function

PFRS - Priority flow regulator
Static signal type
PFRD - Priority flow regulator
Dynamic signal type

2 Size

16 - 16 size

3 Seal material

U - Urethane (standard)

4 Valve housing material

O - Cartridge only
A - Aluminum
S - Steel (standard)

5 Port size

Code	Port size		Housing number	
	Port 2, 3, 4	Port 5	Aluminium	Steel
000	No Body	-	-	-
12T	SAE 12	SAE 4	4994880-001	4994881-001
16T	SAE 16	SAE 4	4994880-002	4994881-002
06G	3/4" BSPP	1/4" BSPP	4994880-003	4994881-003
08G	1" BSPP	1/4" BSPP	4994880-004	4994881-004

*These model digits will not be stamped on the valve.
See section J for housing details.

6 Control pressure

PFRS options

065 - 65 psi (4.5 bar)
130 - 130 psi (8.9 bar)
160 - 160 psi (11.0 bar)

PFRD options

080 - 80 psi (5.5 bar)
110 - 110 psi (7.6 bar)
130 - 130 psi (9.0 bar)

7 Special features

00 - None
(Only required if valve has special features, omit if ("00"))

Dimensions

mm (inch)

Torque cartridge in housing
A - 108-122 Nm (80-90 ft lbs)
B - 136-149 Nm (100-110 ft lbs)

Note: Standard housings include port 1, however for most applications this port must be blocked.

Cartridge only

Basic code
PFRD/S-16

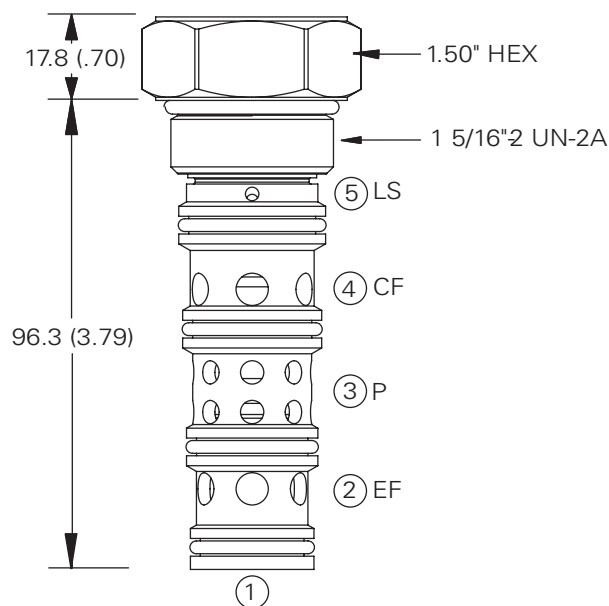

Installation drawing (Steel)

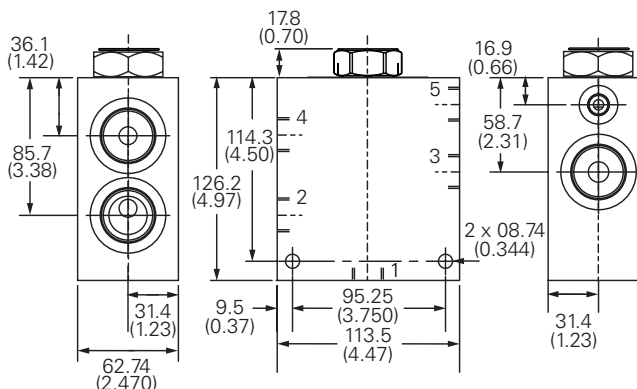

Warning

Aluminum housings can be used for pressures up to 210 bar (3000 psi). Steel housings **must** be used for operating pressures **above** 210 bar (3000 psi).

Where measurements are critical request certified drawings. We reserve the right to change specifications without notice.