



Sun FLeX Series Solenoid Valves

HIGH RELIABILITY

10-million on-off operational cycles

ZINC-NICKEL COATING STANDARD

Offers 1,000-hour salt fog protection

USES 740 & 747 SERIES DC COILS

High-power & hazardous location coils

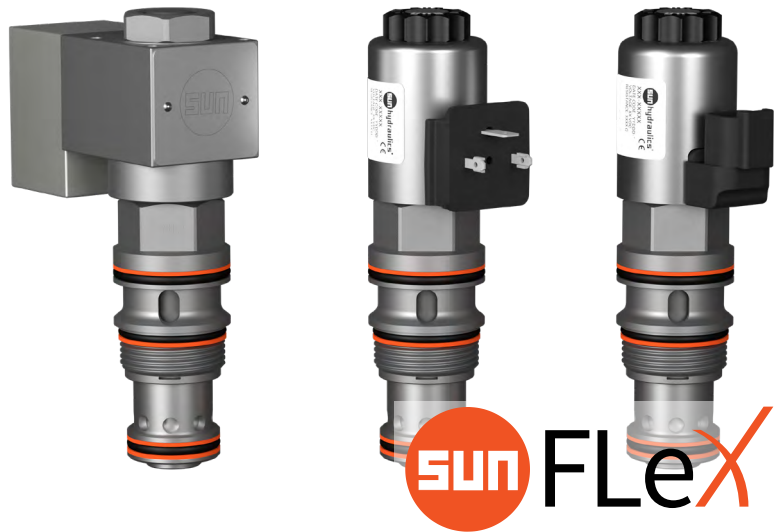

FREP

5000 psi (350 bar)
T-17A cavity

3-WAY, DIRECT-ACTING
ELECTRO-PROPORTIONAL,
BYPASS/RESTRICTIVE
PRIORITY FLOW CONTROL VALVE

PATENT PENDING

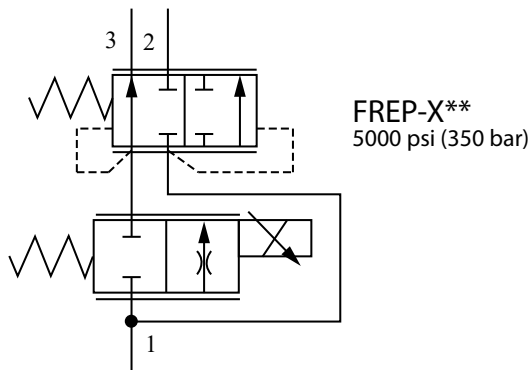

TABLE OF CONTENTS

Valve Functionality	2
Technical Features	2
Model Configurations & Options	3
Technical Specifications	4
Performance Curves	5
Dimensional Drawings	7
Cavity Drawings	8
Accessories	9

sunhydraulics.com/model/FREP

FREP 3-WAY, DIRECT-ACTING
ELECTRO-PROPORTIONAL,
BYPASS/RESTRICTIVE
PRIORITY FLOW CONTROL VALVE

SERIES 3, CAVITY: T-17A

FREP-X**

Function: When de-energized, the throttle spool (1) creates a blocked flow path from port 1 to port 3. The compensator spool (2) creates a blocked flow path from port 1 to port 2. When energized, the throttle spool (1) creates an open unidirectional flow path from port 1 to port 3. The compensator spool (2) creates an open unidirectional flow path from port 1 to port 2 while restricting flow from port 1 to port 3.

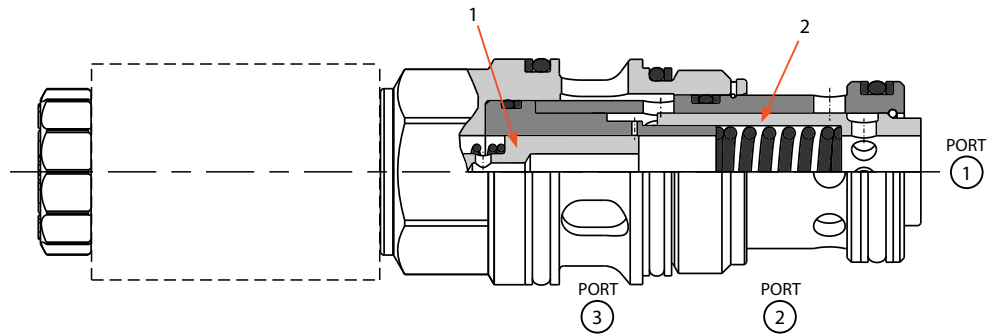
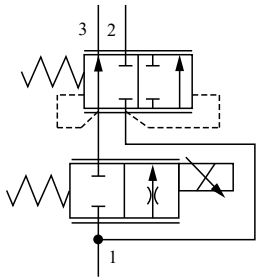

This valve is a normally closed, electro-proportional, bypass/restrictive, priority flow control valve. The valve takes an input flow at port 1 and uses it to satisfy the priority flow at port 3. If the input flow exceeds the priority requirement, the excess is bypassed out port 2.

The valve pressure compensates the priority flow for precise flow regulation in applications where there may be wide pressure fluctuations. Port 2 may also be completely blocked so that the valve can be used as a 2-way electro-proportional pressure compensated flow control from 1 to 3.

TECHNICAL FEATURES

- Incorporates the Sun floating-style construction to minimize the possibility of internal parts binding due to excessive installation torque and/or cavity/cartridge machining variations.
- FLeX Series proportional valves are fully compatible with the XMD Expandable Mobile Drivers from Sun.
- Designed and tested to exceed 10 million on-off operational cycles at full rated pressure.
- Exceeds the new NFPA test standard T2.6.1 R2014 for fatigue and burst pressure ratings.
- Both priority and bypass flow are usable up to the system operating pressure.
- Priority flow remains relatively constant regardless of variation in input flow.
- Bypass flow is not available until priority flow requirements are satisfied.
- Pressure at the bypass port (port 2) may exceed pressure at the priority port (port 3).
- In applications where the priority flow will be completely blocked, bypass pressure drop will increase over time unless a leak path is provided for the priority flow.
- Designed using CFD fluid simulation for optimized geometries.
- For optimum performance, use an amplifier with current feedback and adjustable dither (80 - 250 Hz).
- Zinc-nickel plating standard for 1000-hour salt fog protection.
- Can be used with the 740 Series high-power and 747 Series hazardous location coils.
- A wide variety of coil termination and voltage options are available, with and without surge protection. See the CONFIGURATION section.
- Coil connector options offer ratings up to IP69K. See individual coil product pages for details.

MODEL CODE EXPLANATION

Sun cartridges have a base seven-digit part number. Each of the digits in the sequence has significance as shown in the model code explanation below. Available options

and modifiers for specific cartridges, manifolds, and valve packages are shown on the individual product pages and data sheets. Not all modifiers are applicable for every model.

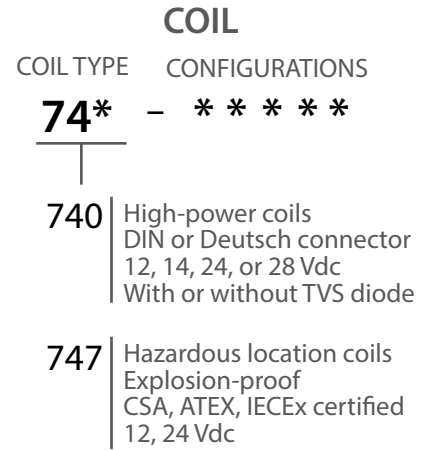
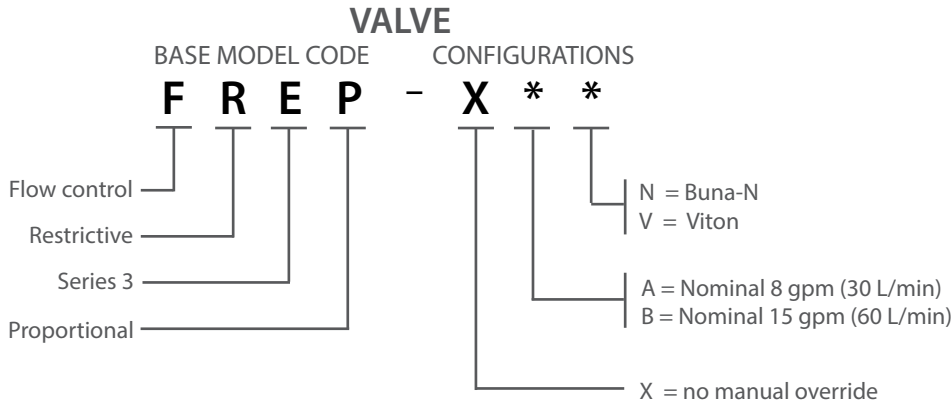

Important Note:

When performing model code searches on www.sunhydraulics.com, do not include setting(s). When ordering, no spaces or dashes are used.

See individual coil data sheets for full coil configuration.

COMPATIBLE COILS

High-Power (25-W) Coils

Voltage	DIN 43650 Form A (IP65/IP67)	AMP Junior Connector Adaptor Kit	Twin Leads Connector Adaptor Kit	Metri-Pack, Series 150-2M Connector Adapter	Deutsch DT04-2P (IP69K)	Resistance @20°C (ohms) ±10% (with diode*)	TVS Diode (Nominal Breakdown Voltage (with diode*))
12 Vdc	740-212	740-612	740-712	740-812	740-912	5.8 Ω	68 Vdc
14 Vdc	740-214	740-614	740-714	740-814	740-914	7.8 Ω	68 Vdc
24 Vdc	740-224	740-624	740-724	740-824	740-924	23.0 Ω	68 Vdc
28 Vdc	740-228	740-628	740-728	740-828	740-928	31.4 Ω	68 Vdc

* Above model codes are shown without transient voltage suppression (TVS) diodes. To order 740 Series coils with a TVS diode, append model code with "D" (Example: 740-212D).

Hazardous Location, Explosion-Proof (30-W) Coils

Voltage	M20 x 1.5 180°	M20 x 1.5 90°	1/2" NPT 180°	1/2" NPT 90°	Wattage @ 20°C	Circuitry
12 Vdc	747-JM12BD	747-JM12CD	747-JN12BD	747-JN12CD	29.6 W	With diode
24 Vdc	747-JM24BD	747-JM24CD	747-JN24BD	747-JN24CD	29.9 W	With diode

FREP 3-WAY, DIRECT-ACTING
ELECTRO-PROPORTIONAL,
BYPASS/RESTRICTIVE
PRIORITY FLOW CONTROL VALVE

TECHNICAL SPECIFICATIONS	
Sun Cavity	T-17A
Sun Cartridge Series	Series 3
Maximum Flow Rate/Capacity	30 gpm (120 L/min)
Maximum Operating Pressure	5000 psi (350 bar)
Response Time - Typical	50 ms (open & close)
Typical Internal Leakage at 110 SUS (24 cSt) from port 1 to 3 @ 1450 psi (100 bar)	30 mL/min @ 1450 psi (100 bar)
Typical Internal Leakage at 110 SUS (24 cSt) from port 1 to 3 @ 5000 psi (350 bar)	110 mL/min @ 5000 psi (350 bar)
Switching Frequency - Maximum	1 Hz (3,600 cycles/hour)
Recommended Dither Frequency	100 Hz
Typical Hysteresis (at Recommended Dither)	A: 9%, B: 7%
Typical Linearity (at Recommended Dither)	A: 2%, B: 3%
Typical Repeatability (at Recommended Dither)	1.5%
Typical Deadband, Nominal (as Percent of Coil Current)	25%
Manual Override Option	No
Viscosity Range	2,8 to 380 cSt or 35 to 2000 SUS
Filtration	Minimum cleanliness (ISO 4406 1999, 4/6/14 µm) 18/16/13
Valve Hex Size	1-1/4 in (31,7 mm)
Valve Installation Torque	150-160 lbf ft (203-217 N-m)
Mounting Position	No restrictions
Valve Weight (excluding coil)	1.2 lbs (0.5 kg)
Seal Kit - Viton	990-017-006
Seal Kit - Buna	990-017-007

PERFORMANCE CURVES

FREP
Typical Bypass Pressure Differential vs. Flow

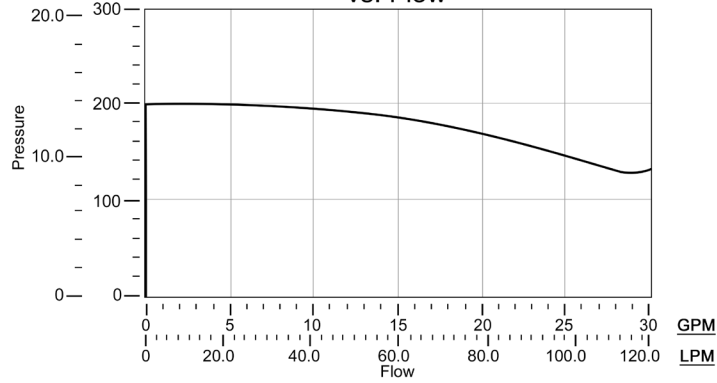

FREP
Flow vs. Command

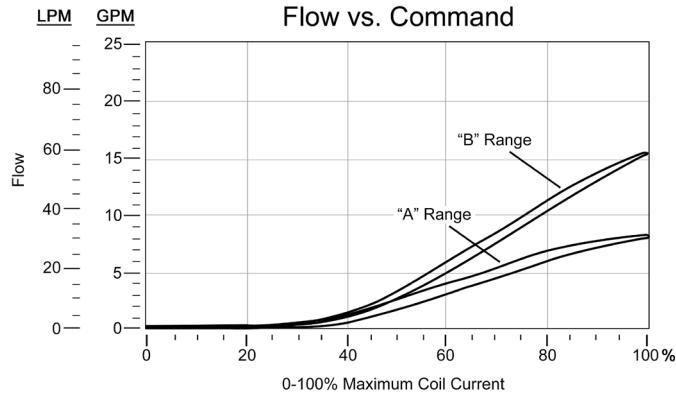

FREP-*A*
Typical Priority Flow
with 20 GPM (75.7 LPM) Inlet

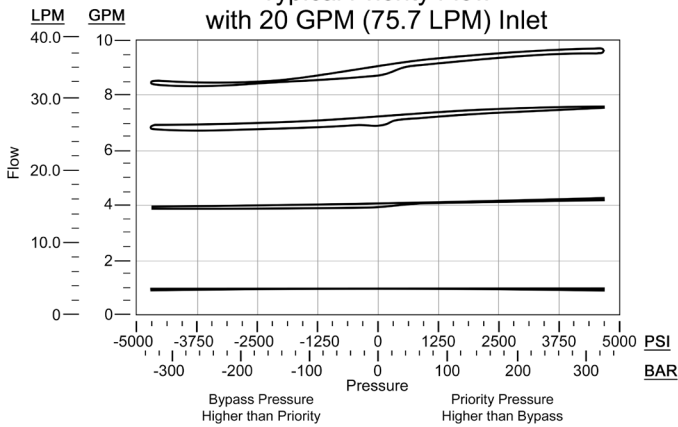

FREP-*B*
Typical Priority Flow
with 20 GPM (75.7 LPM) Inlet

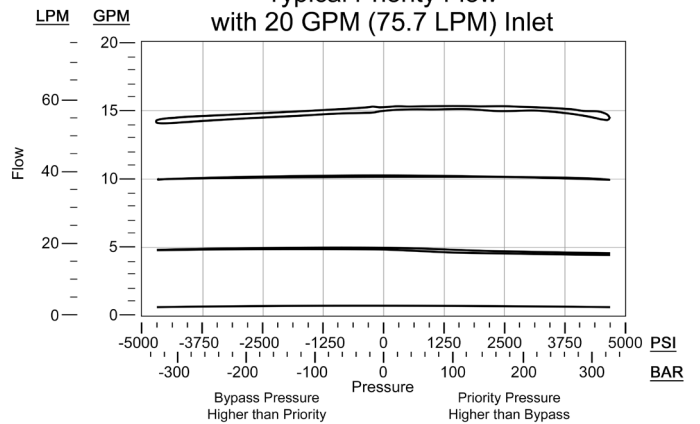

PERFORMANCE CURVES (CONTINUED)

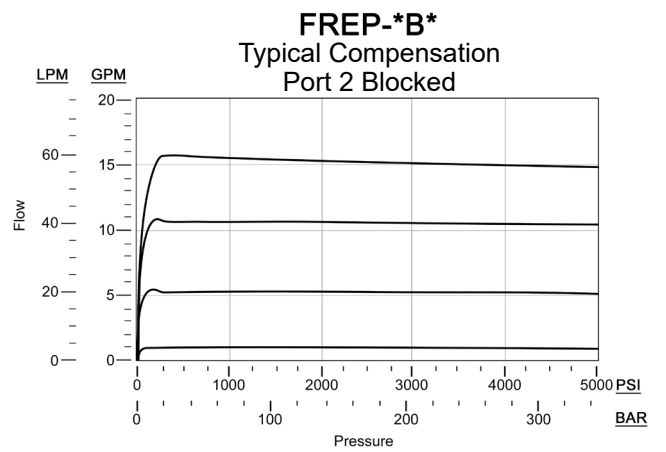
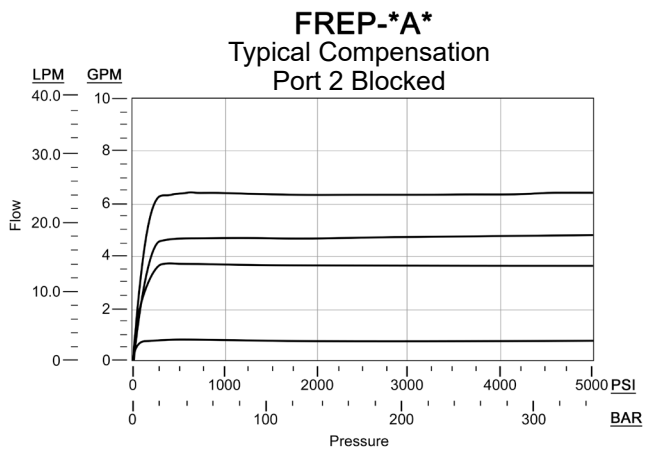
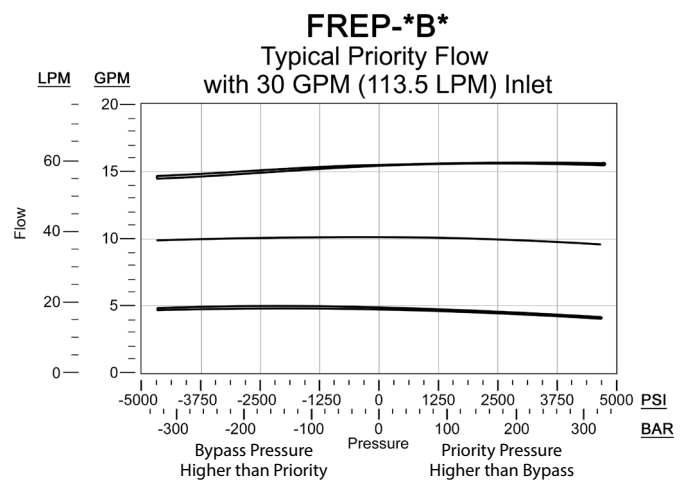
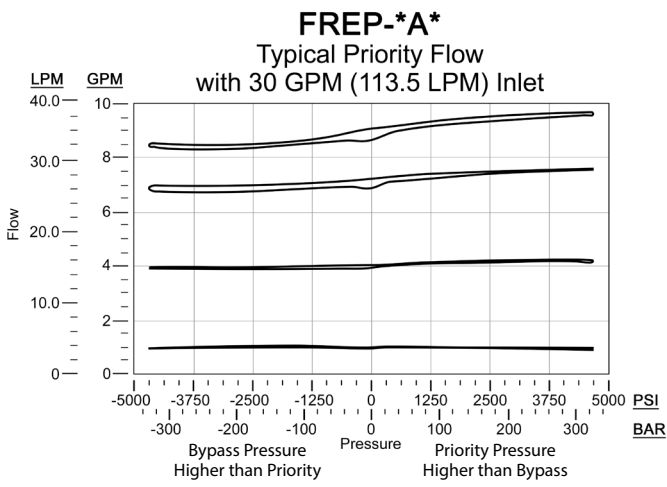

FREP WITH 740 SERIES HIGH-POWER COILS

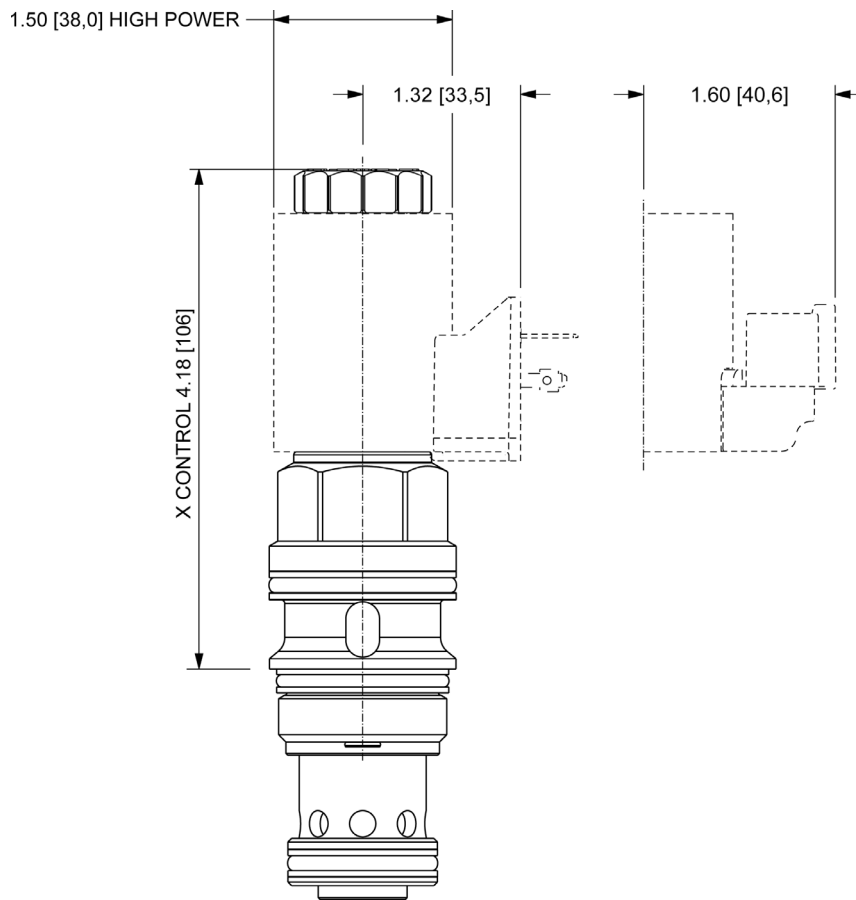

747 SERIES HAZARDOUS LOCATION COILS

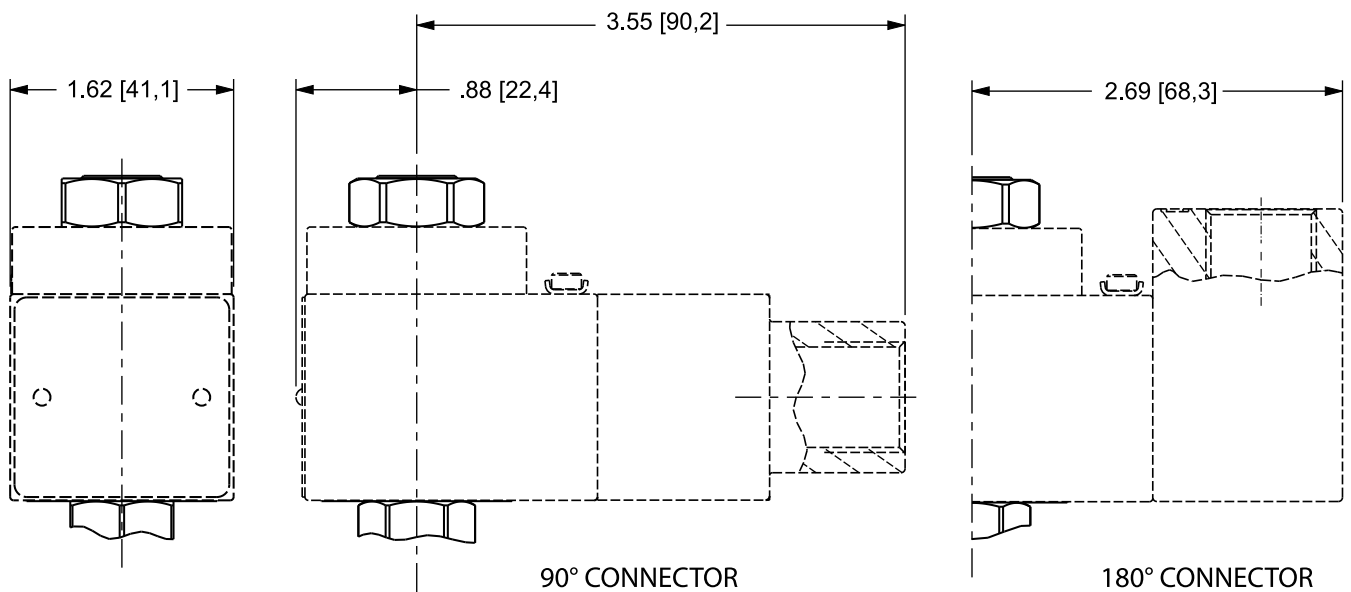

NOTE: Please verify cartridge clearance requirements when choosing a Sun manifold. Different valve controls and coils require different clearances. An additional minimum 2.0 in. (50,8 mm) beyond the valve extension is needed for coil installation and removal.

T-17A CAVITY DIMENSIONAL DRAWING

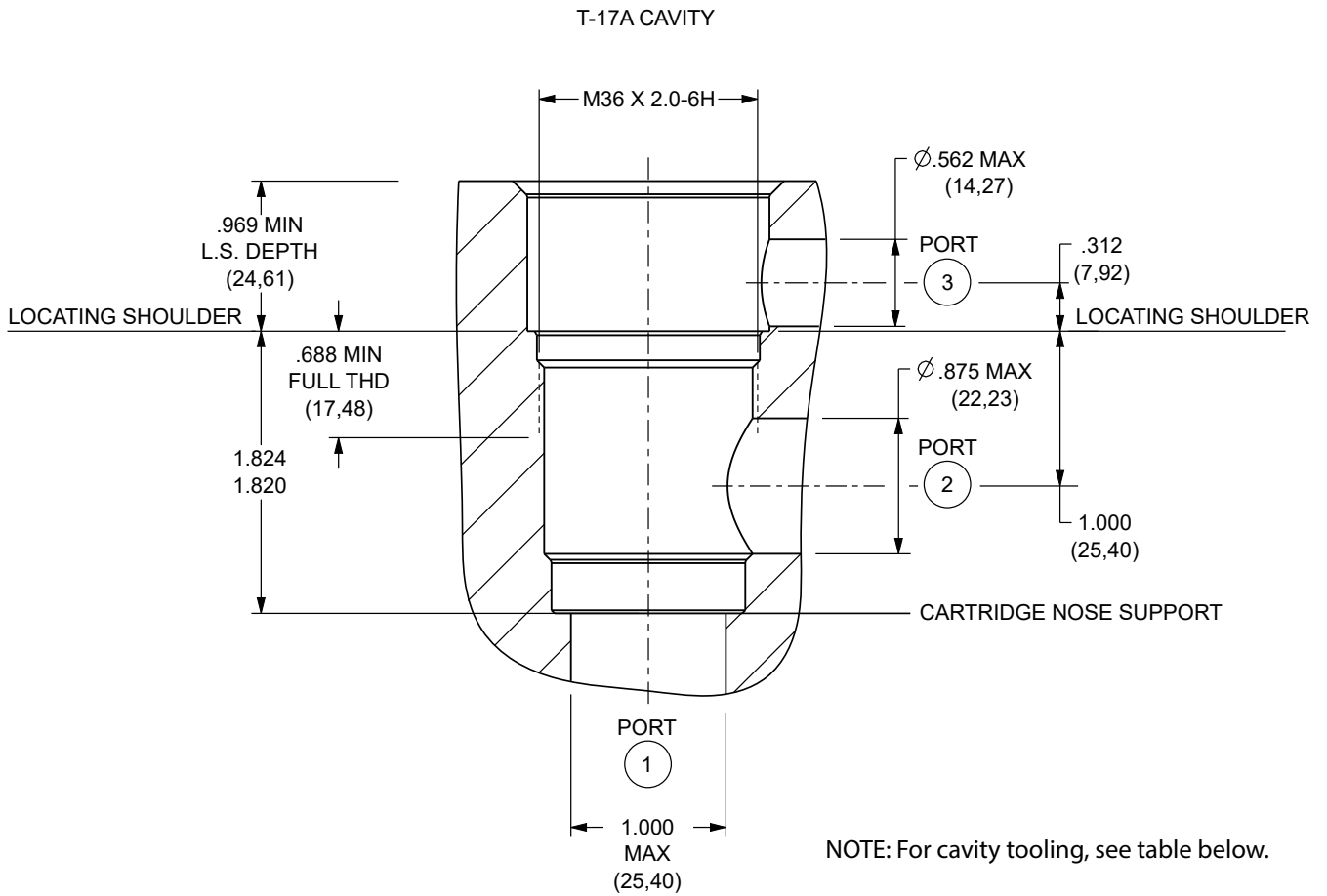

NOTE: For cavity tooling, see table below.

For full cavity detail, download the latest drawings from our website.

www.sunhydraulics.com/cavity/T-17A

T-17A CAVITY TOOLING

DESCRIPTION	HIGH-SPEED STEEL	TITANIUM COATED
M36 X 2-6H tap, straight shank	998996	998996101
Series 3 deep hex socket	998100003	
T-17A cavity form drill, morse taper	994017001	994017101
T-17A cavity form drill, straight shank	994017002	994017102
T-17A cavity form reamer, morse taper	995017001	995017101
T-17A cavity form reamer, straight shank	995017002	995017102

ACCESSORIES

XMD Single- and Dual-Output Drivers

The XMD is a single- or dual-output driver used with solenoid-operated electro-proportional valves for the mobile and industrial hydraulic industries. The driver can be mounted on a manifold using the standard mount clip or directly to the 740 Series low- and high-power coils using an optional coil-mount clip.

DESCRIPTION	PART NUMBER
Single-output PWM driver with standard mounting bracket	XMD-01
Dual-output PWM driver with standard mounting bracket	XMD-02



Wire Harnesses

DESCRIPTION	PART NUMBER
Wire harness, 2-pin Deutsch-to-Metri-Pack Conversion	991-717
Wire harness, 2-pin Deutsch-to-Amp Jr Timer Conversion	991-718
Wire harness, 2-pin Deutsch-to-Twin-Lead Conversion	991-719

MOTOR-MOUNT MANIFOLDS – PRIORITY FLOW CONTROL (FREP)



Sun Hydraulics offers six standard OMP motor-mount manifolds designed for the FREP that include a set of deep mounting holes to accommodate Sun’s XMD Mobile Driver. These single-cavity manifolds include versions in a range of port sizes.

These priority flow control manifolds include the following models available on our website: WEC, WED, WEK, WEL, WEV, and WEW. See our WE* listings online: www.SunHydraulics.com/FREP-manifolds.

To search our complete line of more than 4000 standard manifolds, please visit our website: www.SunHydraulics.com/models/manifolds.



Sun Hydraulics Headquarters
Sarasota, Florida USA
+1 941 362 1200

Custom Fluidpower Pty Ltd
(A Sun Hydraulics Company)
Newcastle, Australia
+61 02 4953 5777
sales@custom.com.au

Sun Hydraulics Limited
Coventry, England
+44 2476 217 400
sales@sunuk.com

Sun Hydraulics Korea Corp.
Incheon, Korea
+82 3281 31350
sales@sunhydraulics.co.kr

Sun Hydraulik GmbH
Erkelenz, Germany
+49 2431 80910
sales@sunhydraulik.de

Sun Hydraulics China Co. Ltd.
Shanghai, P.R. China
+86 2162 375885
sunchinainfo@sunhydraulics.com

Sun Hydraulics Corp. (India)
Bangalore, India
+91 8028 456325
sunindiainfo@sunhydraulics.com

Sun Hydraulics Corp. (S.America)
Rosario, Argentina
+54 9 341 584 3075
ventas@sunhydraulics.com