

# Gelenkköpfe

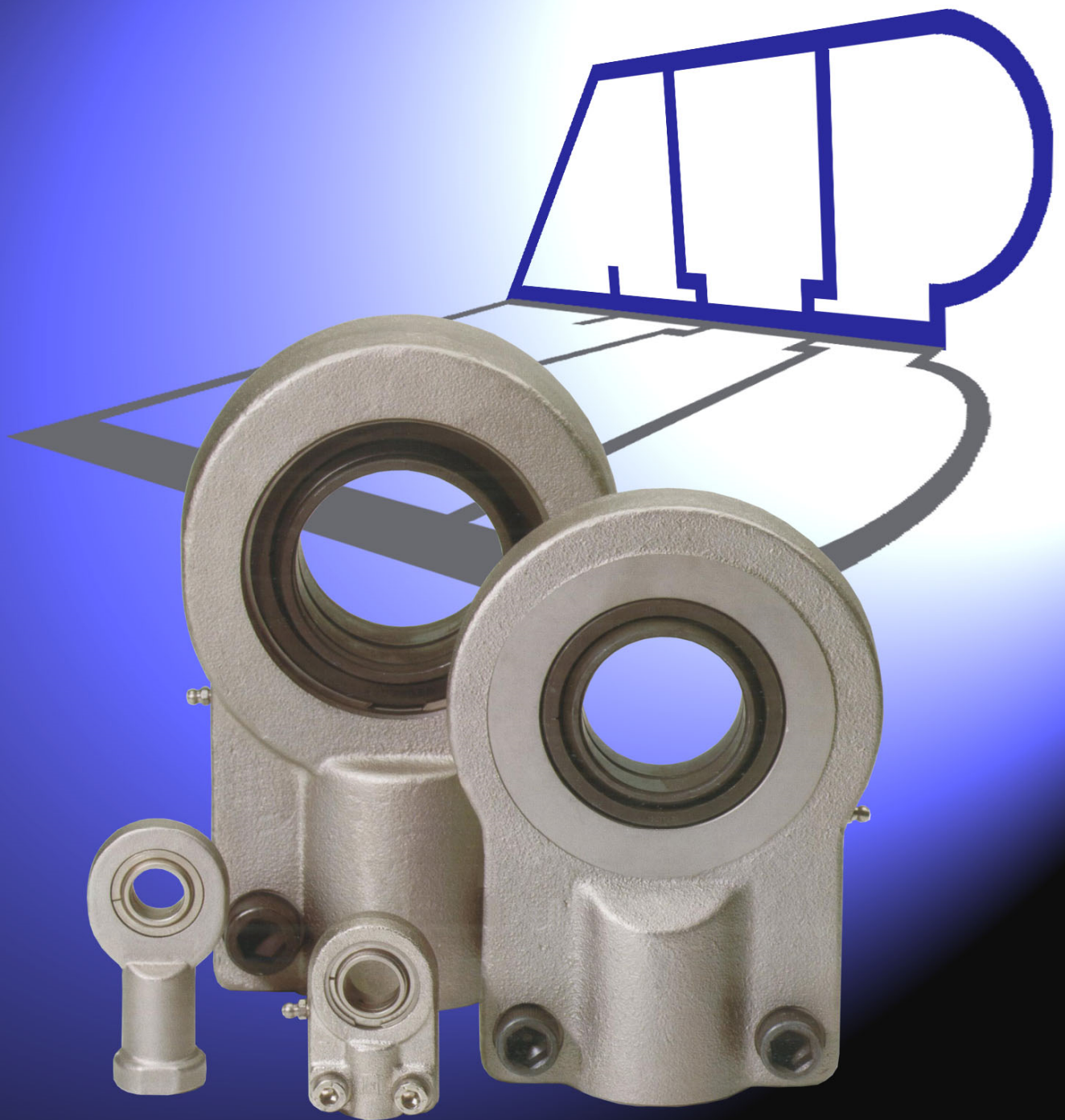

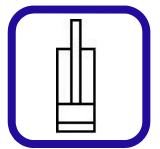

# Gelenkkopf

## Inhaltsverzeichnis

Gelenkkopf.....	2
TS...C (GK...DO).....	2
TS...N (GF...DO).....	3
TS...CE-N.....	4
TAPR...N (GIHR...DO).....	5
TAPR...U (GIHR-K...DO).....	6
TAPR...CE (GIHNR-K...LO).....	7
TFI...FK (GIR...DO).....	8
TFI...FK-2RS (GIR...DO-2RS).....	8
TFI...FK-2RS MAG.....	8
TFE...MK (GAR...DO).....	9
TFE...MK-2RS (GAR...DO-2RS).....	9
TFE...MK-2RS MAG.....	9
TFE...MKB (GAR...UK).....	10
TFE...T-2RS (GAR...UK-2RS).....	10
TFE...T-2RS MAG.....	10
Anwendungsrichtlinien für Gelenkköpfe.....	11
Type: TS...C (GK...DO).....	11
Type: TS...N (GF...DO).....	11
Type: TAPR...N (GIHR...DO).....	11
Type: TAPR...U (GIHR-K...DO).....	12
Type: TAPR...CE / TAPR...S (GIHN-K...LO / GIHO-K...DO).....	12
Type: TFI...FK / TFI...FK-2RS (GIR...DO / GIR...DO 2RS).....	12
Type: TFE...MK / TFE...MK-2RS (GAR...DO / GAR...DO 2RS).....	13
Type: TFI...FKB / ...T-2RS (GIR...UK / GIR...UK 2RS).....	13
Type: TFE...T / 2RS MAG. (GAR...UK / GAR...UK 2RS).....	13

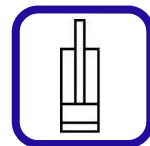

# Gelenkkopf

TS...C (GK...DO)

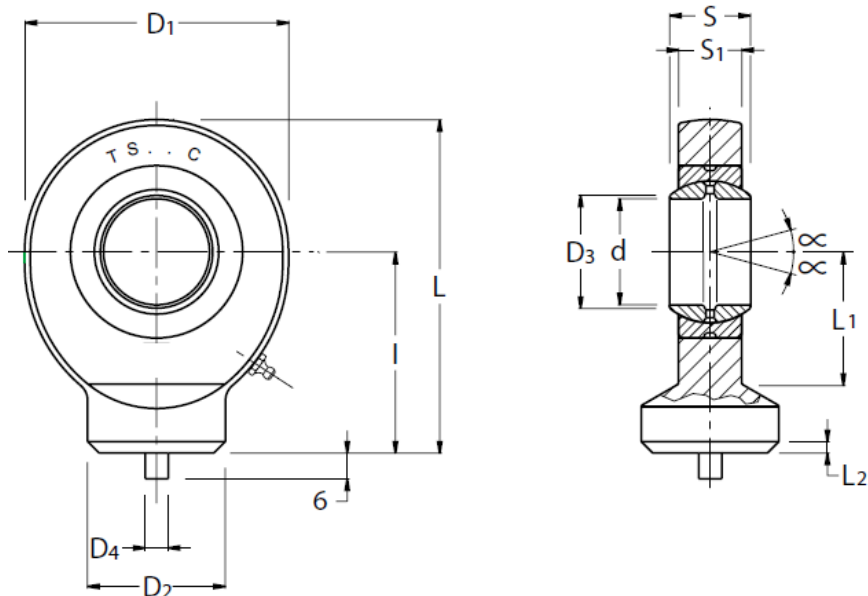

Artikel	d	Toleranz		S	D3	I	D1	D2	S1	L	L1	L2	D4	Ladefaktoren		Radiales Spiel	Schwenkwinkel	Gewicht kg	ATP-Artikel-Nr.
		d	S											Dynamisch C	Statisch Co				
		mm																	
TS 10 C	10	0±-0.008	0±-0.12	9	13.2	24	29	15	7	38.5	15	2	3	8.15	15.6	0.023-0.068	12	0.04	256 890 010
TS 12 C	12	0±-0.008	0±-0.12	10	15	27	34	17.5	8	44	18	2	3	10.8	21.6	0.023-0.068	11	0.06	256 890 012
TS 15 C	15	0±-0.008	0±-0.12	12	18.4	31	40	21	10	51	20	2.5	4	17	32	0.030-0.082	8	0.12	256 890 015
TS 16 C	16	0±-0.008	0±-0.12	14	20.7	35	46	24	11	58	23	3	4	19	36	0.030-0.082	9	0.17	256 890 016
TS 17 C	17	0±-0.008	0±-0.12	14	20.7	35	46	24	11	58	23	3	4	21.2	40	0.030-0.082	10	0.18	256 890 017
TS 20 C	20	0±-0.008	0±-0.12	16	24.1	38	53	27.5	13	64.5	27.5	3	4	30	54	0.030-0.082	9	0.26	256 890 020
TS 25 C	25	0±-0.010	0±-0.12	20	29.3	45	64	33.5	17	77	33	4	4	48	72	0.037-0.100	7	0.45	256 890 025
TS 30 C	30	0±-0.010	0±-0.12	22	34.2	51	73	40	19	87.5	37.5	4	4	62	95	0.037-0.100	6	0.67	256 890 030
TS 35 C	35	0±-0.010	0±-0.12	25	39.7	61	82	47	21	102	43	4	4	80	125	0.037-0.100	6	1.02	256 890 035
TS 40 C	40	0±-0.012	0±-0.12	28	45	69	92	52	23	115	48	5	4	100	156	0.043-0.120	7	1.40	256 890 040
TS 45 C	45	0±-0.012	0±-0.12	32	50.7	77	102	58	27	128	52	5	6	127	208	0.043-0.120	7	1.93	256 890 045
TS 50 C	50	0±-0.012	0±-0.12	35	56	88	112	62	30	144	59	6	6	156	250	0.043-0.120	6	2.69	256 890 050
TS 60 C	60	0±-0.012	0±-0.15	44	66.8	100	135	70	38	167.5	72.5	8	6	245	390	0.043-0.120	6	4.60	256 890 060
TS 70 C	70	0±-0.015	0±-0.15	49	77.8	115	160	80	42	195	86	10	6	315	510	0.055-0.142	6	7.00	256 890 070
TS 80 C	80	0±-0.015	0±-0.15	55	89.4	141	180	95	47	231	98	10	6	400	620	0.055-0.142	6	11.00	256 890 080

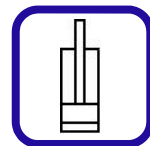

### TS...N (GF...DO)

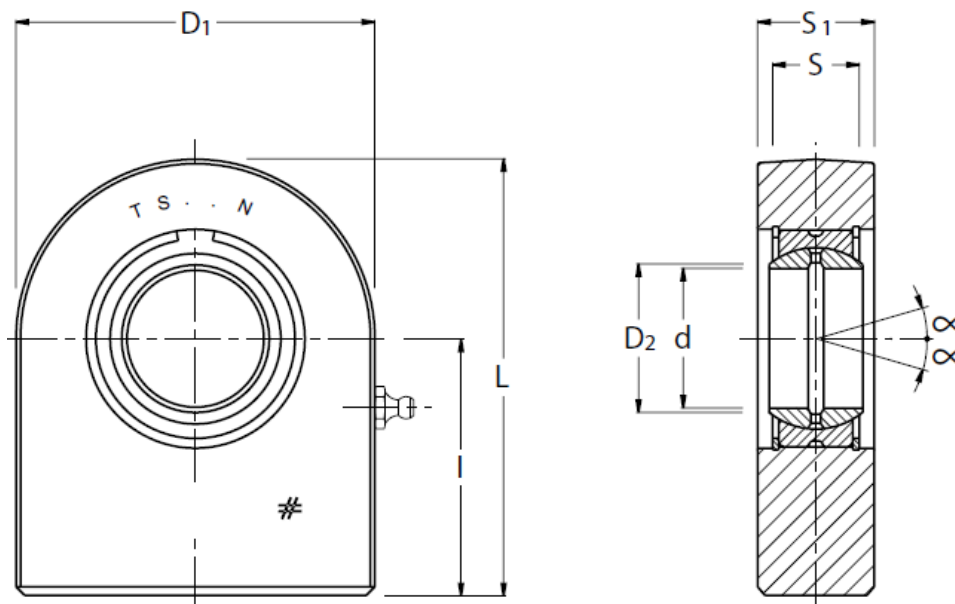

Artikel	d	Toleranz		S	D2	I	D1	S1	L	Ladefaktoren		Radiales Spiel	Schwenkwinkel	Gewicht kg	ATP-Artikel-Nr.
		d	S							Dynamisch	Statisch Co				
		Mm								KN	mm				
TS 15 N	15	0÷-0.008	0÷-0.12	12	18.4	31	45	16	53.5	17	53	0.022-0.082	8	0.22	
TS 16 N	16	0÷-0.008	0÷-0.12	14	20.7	35	48	17.5	59	21.2	59	0.025-0.082	10	0.29	
TS 17 N	17	0÷-0.008	0÷-0.12	14	20.7	35	48	17.5	59	21.2	65	0.025-0.082	10	0.29	
TS 20 N	20	0÷-0.010	0÷-0.12	16	24.1	38	50	19	63	30	67	0.030-0.082	9	0.36	256 895 020
TS 25 N	25	0÷-0.010	0÷-0.12	20	29.3	45	55	23	72.5	48	69.5	0.037-0.100	7	0.53	256 895 025
TS 30 N	30	0÷-0.010	0÷-0.12	22	34.2	51	65	28	83.5	62	118	0.037-0.100	6	0.85	256 895 030
TS 35 N	35	0÷-0.012	0÷-0.12	25	39.7	61	83	30	102.5	80	196	0.037-0.100	6	1.50	256 895 035
TS 40 N	40	0÷-0.012	0÷-0.12	28	45	69	100	35	119	100	305	0.043-0.120	7	2.42	256 895 040
TS 45 N	45	0÷-0.012	0÷-0.12	32	50.7	77	110	40	132	127	386	0.043-0.120	7	3.39	256 895 045
TS 50 N	50	0÷-0.012	0÷-0.12	35	56	88	123	40	149.5	156	441	0.043-0.120	6	4.24	256 895 050
TS 60 N	60	0÷-0.015	0÷-0.15	44	66.8	100	140	50	170	245	570	0.043-0.120	6	7.10	256 895 060
TS 70 N	70	0÷-0.015	0÷-0.15	49	77.8	115	164	55	197	315	724	0.055-0.142	6	10.70	256 895 070
TS 80 N	80	0÷-0.015	0÷-0.15	55	89.4	141	180	60	231	400	804	0.055-0.142	6	15.10	256 895 080
TS 90 N	90	0÷-0.020	0÷-0.20	60	98.1	150	226	65	263	490	1340	0.055-0.142	5	23.40	256 895 090
TS 100 N	100	0÷-0.020	0÷-0.20	70	109.5	170	250	70	295	610	1516	0.065-0.165	7	33.10	256 895 100
TS 110 N	110	0÷-0.020	0÷-0.20	70	121.2	185	295	80	332.5	655	2340	0.065-0.165	6	48.50	256 895 110
TS 120 N	120	0÷-0.020	0÷-0.20	85	135.5	210	360	90	390	950	3210	0.065-0.165	6	79.50	

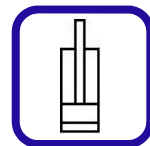

## TS...CE-N

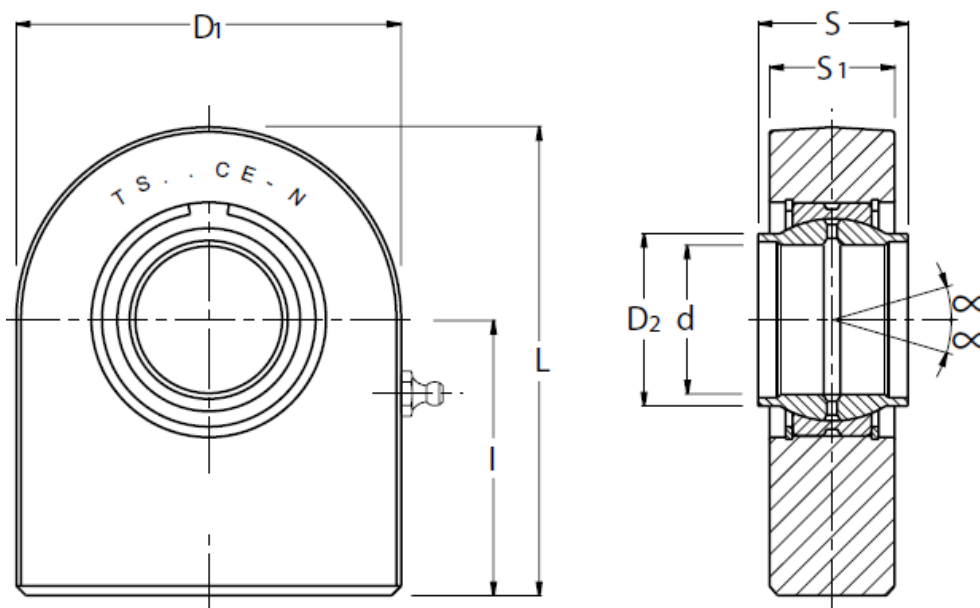

Artikel	d	Toleranz		S	D2	I	D1	S1	L	Ladefaktoren		Radiales Spiel	Schwenkwinkel	Gewicht kg	ATP-Artikel-Nr.
		d	S							Dynamisch C	Statisch Co				
		Mm													
TS 20 CE-N	20	0 $\pm$ +0.021	0 $\pm$ -0.021	20	25	38	50	19	63	30	74	0.030-0.082	4	0.36	256 896 020
TS 25 CE-N	25	0 $\pm$ +0.021	0 $\pm$ -0.021	25	30.5	45	55	23	72.5	48	95	0.037-0.100	4	0.54	256 896 025
TS 32 CE-N	32	0 $\pm$ +0.025	0 $\pm$ -0.025	32	38	65	70	27	103	62.5	168	0.037-0.100	4	1.12	256 896 032
TS 40 CE-N	40	0 $\pm$ +0.025	0 $\pm$ -0.025	40	46	69	100	35	119	100	268	0.043-0.120	4	2.50	256 896 040
TS 50 CE-N	50	0 $\pm$ +0.025	0 $\pm$ -0.025	50	57	88	123	40	149.5	156	362	0.043-0.120	4	4.60	256 896 050
TS 63 CE-N	63	0 $\pm$ +0.030	0 $\pm$ -0.030	63	71.5	107	145	50	178	248	570	0.055-0.142	4	9.30	256 896 063
TS 70 CE-N	70	0 $\pm$ +0.030	0 $\pm$ -0.030	70	79	115	164	55	197	315	800	0.055-0.142	4	11.25	256 896 070
TS 80 CE-N	80	0 $\pm$ +0.030	0 $\pm$ -0.030	80	91	141	180	60	231	400	874	0.055-0.142	4	15.75	256 896 080
TS 90 CE-N	90	0 $\pm$ +0.035	0 $\pm$ -0.035	90	99	150	226	65	263	490	1045	0.055-0.142	4	24.00	256 896 090
TS 100 CE-N	100	0 $\pm$ +0.035	0 $\pm$ -0.035	100	113	170	250	70	295	610	1330	0.065-0.165	4	33.95	256 896 100
TS 110 CE-N	110	0 $\pm$ +0.035	0 $\pm$ -0.035	110	124	185	195	80	332.5	655	1490	0.065-0.165	4	49.00	256 896 110

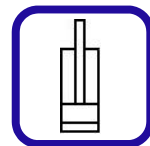

### TAPR...N (GIHR...DO)

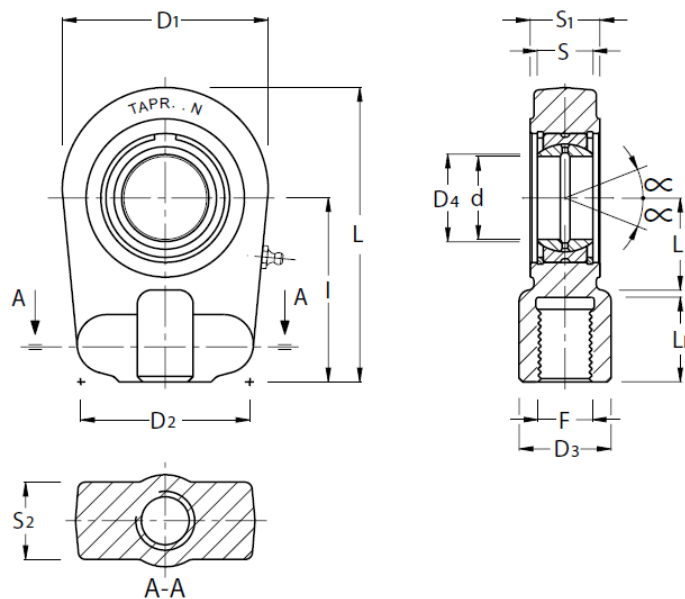

Artikel	d	Toleranz		S	D4	I	D1	D2	S1	S2	L	L1	D3	LF	F	Ladefaktoren		Radiales Spiel	Schwenkwinkel	Gewicht kg	ATP-Artikel-Nr.
		d	S													Dynamisch C	Statisch Co				
		Mm															KN				
TAPR 20 N	20	0±-0.010	0±-0.12	16	24.1	50	56	46	19	17	80	25	25	17	M16x1,5	30	81.1	0.030-0.082	0.45	9	256 882 020
TAPR 25 N	25	0±-0.010	0±-0.12	20	29.3	50	56	46	23	21	80	28	25	17	M16x1,5	48	72	0.037-0.100	0.49	7	256 882 025
TAPR 30 N	30	0±-0.010	0±-0.12	22	34.2	60	64	50	28	36	94	30	32	23	M22x1,5	62	106	0.037-0.100	0.76	6	256 882 030
TAPR 35 N	35	0±-0.012	0±-0.12	25	39.7	70	78	66	30	38	112	38	40	29	M28x1,5	80	153	0.037-0.100	1.26	6	256 882 035
TAPR 40 N	40	0±-0.012	0±-0.12	28	45	85	94	76	35	33	135	45	49	36	M35x1,5	100	250	0.043-0.120	2.15	7	256 882 040
TAPR 50 N	50	0±-0.012	0±-0.12	35	56	105	116	90	40	37	168	55	61	46	M45x1,5	156	365	0.043-0.120	3.80	6	256 882 050
TAPR 60 N	60	0±-0.015	0±-0.15	44	66.8	130	130	120	50	46	200	65	75	59	M58x1,5	245	400	0.043-0.120	6.20	6	256 882 060
TAPR 70 N	70	0±-0.015	0±-0.15	49	77.8	150	154	130	55	51	232	75	86	66	M65x1,5	315	540	0.055-0.142	9.83	6	256 882 070
TAPR 80 N	80	0±-0.015	0±-0.15	55	89.4	170	176	160	60	55	265	80	105	81	M 80x2	400	670	0.055-0.142	13.97	6	
TAPR 90 N	90	0±-0.020	0±-0.20	60	98.1	210	206	180	65	60	322	90	124	101	M100x2	490	980	0.055-0.142	23.50	5	256 882 090
TAPR 100 N	100	0±-0.020	0±-0.20	70	109.5	235	231	200	70	65	360	105	138	111	M110x2	610	1120	0.065-0.165	32.00	7	
TAPR 110 N	110	0±-0.020	0±-0.20	70	121.2	265	266	220	80	74	407	115	152	125	M120x3	655	1700	0.065-0.165	41.00	6	
TAPR 120 N	120	0±-0.020	0±-0.20	85	135.5	310	340	257	90	84	490	140	172	135	M130x3	950	2900	0.065-0.165	72.00	6	

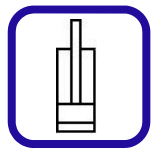

### TAPR...U (GIHR-K...DO)

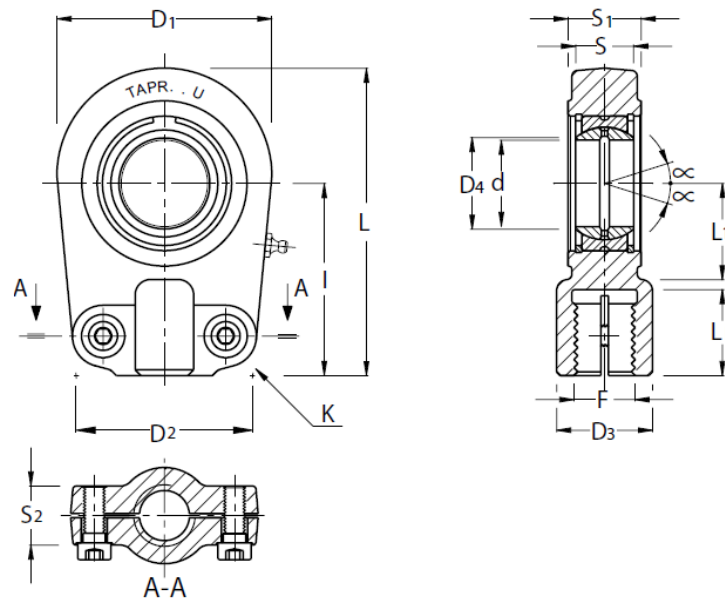

Artikel	d	Toleranz		S	D4	I	D1	D2	S1	S2	L	L1	D3	LF	F	Ladefaktoren		Radiales Spiel	Schwenkwinkel	Gewicht kg	Schraube K UNI 5931	Schrauben Kupplung Nm	ATP-Artikel-Nr.
		d	S													Dynamisch C	Statisch Co						
		Mm															KN						
TAPR 20 U	20	0±-0.010	0±-0.12	16	24.1	50	56	46	19	17	80	25	25	17	M16x1,5	30	81.1	0.030-0.082	9	0.44	M8x18	25	256 884 020
TAPR 25 U	25	0±-0.010	0±-0.12	20	29.3	50	56	46	23	21	80	28	25	17	M16x1,5	48	72	0.037-0.100	7	0.47	M8x20	25	256 884 025
TAPR 30 U	30	0±-0.010	0±-0.12	22	34.2	60	64	50	28	36	94	30	32	23	M22x1,5	62	106	0.037-0.100	6	0.77	M8x25	25	256 884 030
TAPR 35 U	35	0±-0.012	0±-0.12	25	39.7	70	78	66	30	38	112	38	40	29	M28x1,5	80	153	0.037-0.100	6	1.24	M10x30	49	256 884 035
TAPR 40 U	40	0±-0.012	0±-0.12	28	45	85	94	76	35	33	135	45	49	36	M35x1,5	100	250	0.043-0.120	7	2.12	M10x35	49	256 884 040
TAPR 50 U	50	0±-0.012	0±-0.12	35	56	105	116	90	40	37	168	55	61	46	M45x1,5	156	365	0.043-0.120	6	3.74	M12x40	86	256 884 050
TAPR 60 U	60	0±-0.015	0±-0.15	44	66.8	130	130	120	50	46	200	65	75	59	M58x1,5	245	400	0.043-0.120	6	6.49	M16x45	210	256 884 060
TAPR 70 U	70	0±-0.015	0±-0.15	49	77.8	150	154	130	55	51	232	75	86	66	M65x1,5	315	540	0.055-0.142	6	9.88	M16x50	210	256 884 070
TAPR 80 U	80	0±-0.015	0±-0.15	55	89.4	170	176	160	60	55	265	80	105	81	M 80x2	400	670	0.055-0.142	6	14.20	M20x55	410	256 884 080
TAPR 90 U	90	0±-0.012	0±-0.20	60	98.1	210	206	180	65	60	322	90	124	101	M100x2	490	980	0.055-0.142	5	20.00	M20x60	410	256 884 090
TAPR 100 U	100	0±-0.012	0±-0.20	70	109.5	235	231	200	70	65	360	105	138	111	M110x2	610	1120	0.065-0.165	7	27.50	M24x65	710	256 884 100
TAPR 110 U	110	0±-0.012	0±-0.20	70	121.2	265	266	220	80	74	407.5	115	152	125	M120x3	655	1700	0.065-0.165	6	45.60	M24x80	710	256 884 110
TAPR 120 U	120	0±-0.012	0±-0.20	85	135.5	310	340	257	90	84	490	140	172	135	M130x3	950	2900	0.065-0.165	6	72.00	M24x85	710	

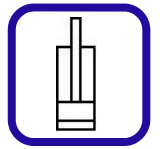
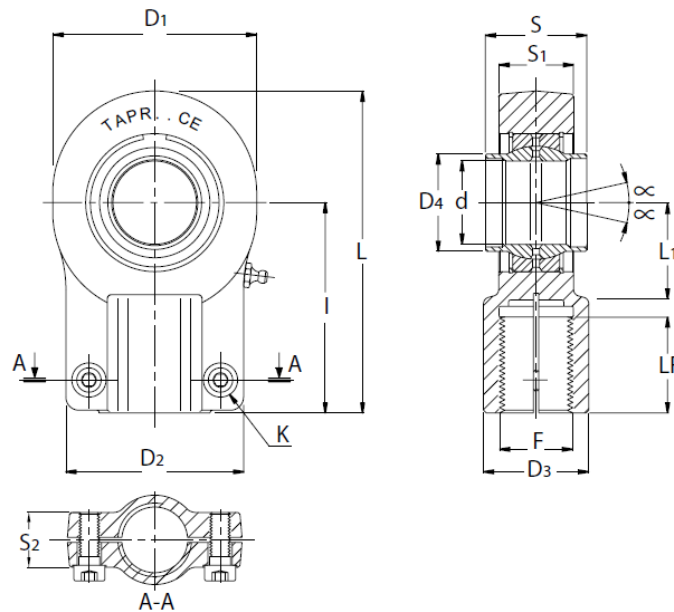
**TAPR...CE (GIHNR-K...LO)**

Artikel	d	Toleranz		S	D4	I	D1	D2	S1	S2	L	L1	D3	LF	F	Ladefaktoren		Radiales Spiel	Schwenkwinkel	Gewicht kg	Schraube K UNI 5931	Schrauben Kupplung Nm	ATP-Artikel-Nr.
		d	S													Dynamisch C	Statisch Co						
		Mm															KN						
TAPR 12 CE	12	0 $\pm$ +0.018	0 $\pm$ -0.18	12	15.5	38	32	32	11	15	54	14	16	17	M12x1.25	10.8	24.5	0.023-0.068	4	0.11	M5x16	6	256 880 012
TAPR 16 CE	16	0 $\pm$ +0.018	0 $\pm$ -0.18	16	20	44	40	40	13	15	64	20	21	19	M14x1.5	17.6	36.5	0.030-0.082	4	0.2	M6x14	10	256 880 016
TAPR 20 CE	20	0 $\pm$ +0.021	0 $\pm$ -0.21	20	25	52	47	47	17	19	75	22	25	23	M16x1,5	30	48	0.030-0.082	4	0.35	M8x20	25	256 880 020
TAPR 25 CE	25	0 $\pm$ +0.021	0 $\pm$ -0.21	25	30.5	65	58	54	22	19	96	27	30	29	M20x1,5	48	78	0.037-0.100	4	0.62	M8x20	25	256 880 025
TAPR 32 CE	32	0 $\pm$ +0.025	0 $\pm$ -0.25	32	38	80	71	66	28	22	118	32	38	37	M27x2	67	114	0.037-0.100	4	1.15	M10x25	49	256 880 032
TAPR 40 CE	40	0 $\pm$ +0.025	0 $\pm$ -0.25	40	46	97	90	80	33	26	146	41	47	46	M33x2	100	204	0.043-0.120	4	2.18	M10x30	49	256 880 040
TAPR 50 CE	50	0 $\pm$ +0.025	0 $\pm$ -0.25	50	57	120	109	96	41	32	179	50	58	57	M42x2	156	310	0.043-0.120	4	3.96	M10x35	86	256 880 050
TAPR 63 CE	63	0 $\pm$ +0.030	0 $\pm$ -0.30	63	71.5	140	136	114	53	38	211	62	70	64	M48x2	255	430	0.055-0.142	4	6.8	M16x40	210	256 880 063
TAPR 70 CE	70	0 $\pm$ +0.030	0 $\pm$ -0.30	70	79	160	155	135	57	42	245	70	80	76	M56x2	315	540	0.055-0.142	4	9.6	M16x40	210	256 880 070
TAPR 80 CE	80	0 $\pm$ +0.030	0 $\pm$ -0.30	80	91	180	170	148	67	48	270	78	90	86	M64x3	400	695	0.055-0.142	4	13	M20x50	410	256 880 080
TAPR 90 CE	90	0 $\pm$ +0.035	0 $\pm$ -0.35	90	99	195	185	160	72	52	296	85	100	91	M 72x3	490	750	0.055-0.142	4	19	M20x60	410	256 880 090
TAPR 100 CE	100	0 $\pm$ +0.035	0 $\pm$ -0.35	100	113	210	211	178	85	62	322	98	110	96	M 80x3	610	1060	0.065-0.165	4	25	M24x60	710	256 880 100
TAPR 110 CE	110	0 $\pm$ +0.035	0 $\pm$ -0.35	110	124	235	235	190	88	62	364	105	125	106	M 90x3	655	1200	0.065-0.165	4	32	M24x60	710	256 880 110
TAPR 125 CE	125	0 $\pm$ +0.040	0 $\pm$ -0.40	125	138	260	265	200	103	72	405	120	135	113	M100x3	950	1430	0.065-0.165	4	46	M24x70	710	256 880 125
TAPR 160 CE	160	0 $\pm$ +0.040	0 $\pm$ -0.40	160	177	310	326	250	130	82	488	150	165	126	M125x4	1370	2200	0.065-0.192	4	82.5	M24x80	710	256 880 160
TAPR 200 CE	200	0 $\pm$ +0.046	0 $\pm$ -0.46	200	221	390	418	320	162	102	620	195	215	161	M160x4	2120	3650	0.065-0.192	4	68	M30x100	1500	256 880 200



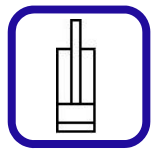

**TFI...FK (GIR...DO)**

**TFI...FK-2RS (GIR...DO-2RS)**

**TFI...FK-2RS MAG**

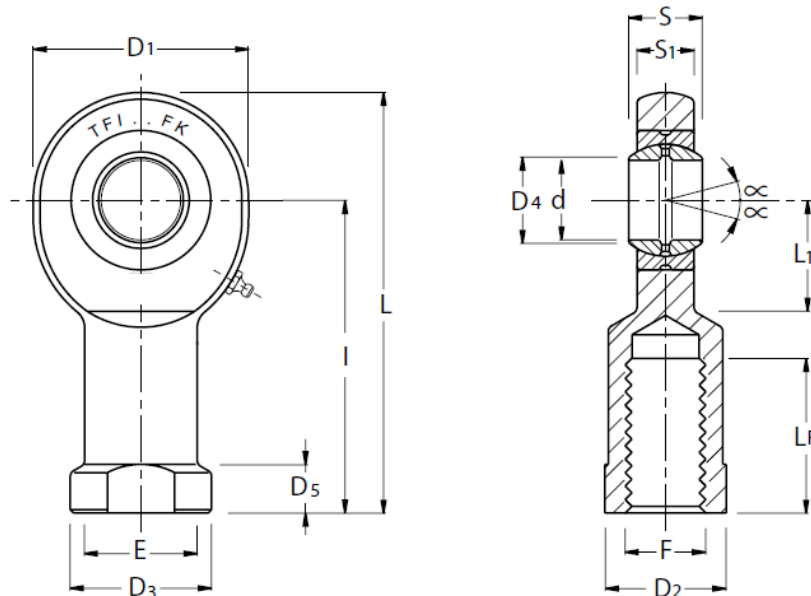

Artikel	d	Toleranz		S	D4	I	D1	D3	E	D2	D5	S1	L	L1	LF	F	Ladefaktoren		Radiales Spiel	Schwenkwinkel	Gewicht kg	ATP-Artikel-Nr.
		d	S														Dynamisch C	Statisch Co				
		Mm																KN				
TFI 6 FK	6	0±-0.008	0±-0.12	6	8	30	21	13	10.5	11	5	4.3	40.5	10.5	11	M6x1	3.4	8.1	0.023-0.068	13	0.02	
TFI 8 FK	8	0±-0.008	0±-0.12	8	10.2	36	24	15	12	13	5	6	48	12	15	M8x1.25	5.5	12.9	0.023-0.068	15	0.04	
TFI 10 FK	10	0±-0.008	0±-0.12	9	13.2	43	29	18	15	15	6.5	7	57.5	14	20	M10x1.5	8.1	17.6	0.023-0.068	12	0.06	256 850 010
TFI 12 FK	12	0±-0.008	0±-0.12	10	15	50	34	20	17	18	6.5	8	67	17.5	24	M12x1.75	10.8	24.5	0.023-0.068	11	0.09	256 850 012
TFI 15 FK	15	0±-0.008	0±-0.12	12	18.4	61	40	24	20	21	8	10	81	20	30	M14x2	17	36	0.030-0.082	8	0.18	256 850 015
TFI 17 FK	17	0±-0.008	0±-0.12	14	20.7	67	46	28	23	24	10	11	90	23	34	M16x2	21.2	45	0.030-0.082	10	0.22	256 850 017
TFI 20 FK	20	0±-0.010	0±-0.12	16	24.1	77	53	35	27.5	32	10	13	103.5	27.5	40	M20x1.5	30	60	0.030-0.082	9	0.35	256 850 020
TFI 25 FK	25	0±-0.010	0±-0.12	20	29.3	94	64	42	33.5	36	12	17	126	32	48	M24x2	48	83	0.037-0.100	7	0.64	256 850 025
TFI 30 FK	30	0±-0.010	0±-0.12	22	34.2	110	73	50	40	41	15	19	146.5	37	56	M30x2	62	110	0.037-0.100	6	0.93	256 850 030
TFI 35 FK-2RS	35	0±-0.012	0±-0.12	25	39.7	125	82	58	47	50	15	21	166	42	60	M36x3	80	146	0.037-0.100	6	1.3	
TFI 40 FK-2RS	40	0±-0.012	0±-0.12	28	45	142	92	65	52	55	18	23	188	48	67	M39x3	100	180	0.043-0.120	7	2.01	
TFI 45 FK-2RS	45	0±-0.012	0±-0.12	32	50.7	145	102	70	58	60	20	27	196	52	65	M42x3	127	240	0.043-0.120	7	2.5	
TFI 50 FK-2RS	50	0±-0.012	0±-0.12	35	56	160	112	75	62	65	20	30	216	59	69	M45x3	156	290	0.043-0.120	6	3.5	
TFI 60 FK-2RS	60	0±-0.015	0±-0.15	44	66.8	175	135	88	70	75	20	38	242	75	73	M52x3	245	450	0.043-0.120	6	5.5	
TFI 70 FK-2RS	70	0±-0.015	0±-0.15	49	77.8	200	160	98	85	80	20	42	280	87	80	M56x4	315	610	0.055-0.142	6	8.6	
TFI 80 FK-2RS	80	0±-0.015	0±-0.15	55	89.4	230	180	110	95	100	25	47	320	100	85	M64x4	400	750	0.055-0.142	6	12	
TFI 40 FK-2RS MAG	40	0±-0.012	0±-0.12	28	45	142	92	65	52	55	18	23	188	48	67	M42x3	100	180	0.043-0.120	7	1.96	
TFI 45 FK-2RS MAG	45	0±-0.012	0±-0.12	32	50.7	145	102	70	58	60	20	27	196	52	65	M45x3	127	240	0.043-0.120	7	2.44	
TFI 50 FK-2RS MAG	50	0±-0.012	0±-0.12	35	56	160	112	75	62	65	20	30	216	59	69	M52x3	156	290	0.043-0.120	6	3.4	
TFI 60 FK-2RS MAG	60	0±-0.015	0±-0.15	44	66.8	175	135	88	70	75	20	38	242	75	73	M60x4	245	450	0.043-0.120	6	6.1	
TFI 70 FK-2RS MAG	70	0±-0.015	0±-0.15	49	77.8	200	160	98	85	80	20	42	280	87	80	M72x4	315	610	0.055-0.142	6	8.7	
TFI 80 FK-2RS MAG	80	0±-0.015	0±-0.15	55	89.4	230	180	110	95	100	25	47	320	100	85	M80x4	400	750	0.055-0.142	6	13.9	

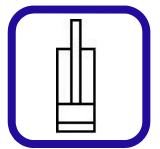

**TFE...MK (GAR...DO)**

**TFE...MK-2RS (GAR...DO-2RS)**

**TFE...MK-2RS MAG**

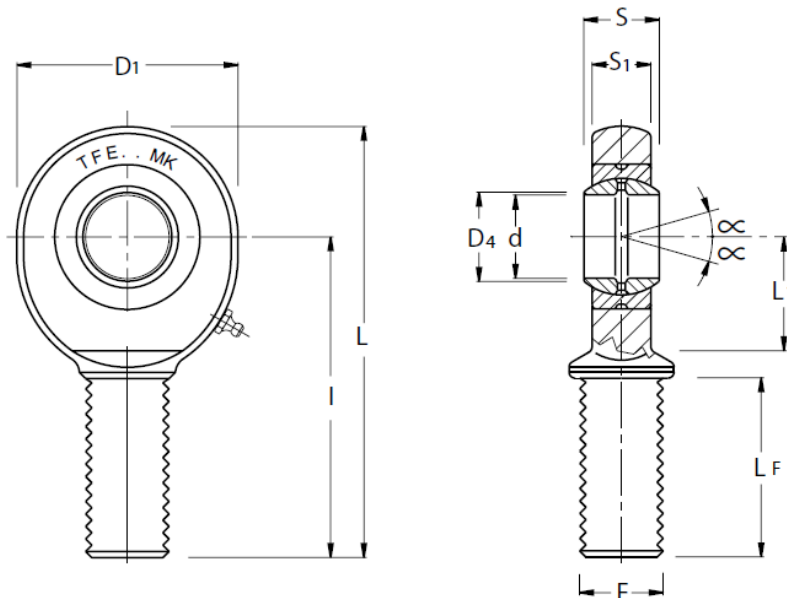

Artikel	d	Toleranz		S	D4	I	D1	S1	L	L1	LF	F	Ladefakto ren		Radiates Spiel	Schwenkwinkel	Gweight kg	ATP-Artikel-Nr.
		d	S										Dynamisch C	Statisch Co				
		mm																
TFE 6 MK	6	0±-0.008	0±-0.12	6	8	36	21	4.3	46.5	12	18	M6x1	3.4	10.2	0.023-0.068	13	0.01	
TFE 8 MK	8	0±-0.008	0±-0.12	8	10.2	42	24	6	54	14	22	M8x1.25	5.5	16	0.023-0.068	15	0.03	256 854 008
TFE 10 MK	10	0±-0.008	0±-0.12	9	13.2	48	29	7	62.5	15	27	M10x1.5	8.1	22	0.023-0.068	12	0.05	256 854 010
TFE 12 MK	12	0±-0.008	0±-0.12	10	15	54	34	8	71	19	30	M12x1.75	10.8	30.4	0.023-0.068	11	0.08	256 854 012
TFE 15 MK	15	0±-0.008	0±-0.12	12	18.4	63	40	10	83	20	34	M14x2	17	44.8	0.030-0.082	8	0.14	
TFE 17 MK	17	0±-0.008	0±-0.12	14	20.7	69	46	11	92	23	36	M16x2	21.2	56.5	0.030-0.082	10	0.19	
TFE 20 MK	20	0±-0.010	0±-0.12	16	24.1	78	53	13	104.5	27.5	43	M20x1.5	30	75.6	0.030-0.082	9	0.31	256 854 020
TFE 25 MK	25	0±-0.010	0±-0.12	20	29.3	94	64	17	126	32	53	M24x2	48	88.2	0.037-0.100	7	0.56	
TFE 30 MK	30	0±-0.010	0±-0.12	22	34.2	110	73	19	146.5	37	65	M30x2	62	119	0.037-0.100	6	0.89	256 854 030
TFE 25 MK-2RS	25	0±-0.010	0±-0.12	20	29.3	94	64	17	126	32	53	M24x2	48	88.2	0.050-0.082	7	0.56	256 854 025
TFE 30 MK-2RS	30	0±-0.010	0±-0.12	22	34.2	110	73	19	146.5	37	65	M30x2	62	119	0.050-0.082	6	0.89	
TFE 35 MK-2RS	35	0±-0.012	0±-0.12	25	39.7	140	82	21	181	43	82	M36x3	80	159	0.037-0.100	6	1.4	256 854 035
TFE 40 MK-2RS	40	0±-0.012	0±-0.12	28	45	150	92	23	196	48	86	M39x3	100	194	0.043-0.120	7	1.8	256 854 040
TFE 45 MK-2RS	45	0±-0.012	0±-0.12	32	50.7	163	102	27	218	52	94	M42x3	127	259	0.043-0.120	7	2.6	
TFE 50 MK-2RS	50	0±-0.012	0±-0.12	35	56	185	112	30	241	60	106	M45x3	156	313	0.043-0.120	6	3.4	256 854 050
TFE 60 MK-2RS	60	0±-0.015	0±-0.15	44	66.8	210	135	38	277.5	75	115	M52x3	245	485	0.043-0.120	6	5.9	
TFE 70 MK-2RS	70	0±-0.015	0±-0.15	49	77.8	235	160	42	315	87	125	M56x4	315	564	0.055-0.142	6	8.2	256 854 070
TFE 80 MK-2RS	80	0±-0.015	0±-0.15	55	89.4	270	180	47	360	100	140	M64x4	400	689	0.055-0.142	6	13.1	
TFE 40 MK-2RS MAG	40	0±-0.012	0±-0.12	28	45	150	92	23	196	48	86	M42x3	100	180	0.043-0.120	7	1.85	
TFE 45 MK-2RS MAG	45	0±-0.012	0±-0.12	32	50.7	163	102	27	218	52	94	M45x3	127	240	0.043-0.120	7	2.66	
TFE 50 MK-2RS MAG	50	0±-0.012	0±-0.12	35	56	185	112	30	241	60	106	M52x3	156	290	0.043-0.120	6	4	
TFE 60 MK-2RS MAG	60	0±-0.015	0±-0.15	44	66.8	210	135	38	277.5	75	115	M60x4	245	450	0.043-0.120	6	6.7	
TFE 70 MK-2RS MAG	70	0±-0.015	0±-0.15	49	77.8	235	160	42	315	87	125	M72x4	315	610	0.055-0.142	6	8.38	
TFE 80 MK-2RS MAG	80	0±-0.015	0±-0.15	55	89.4	271	180	47	360	100	140	M80x4	400	750	0.055-0.142	6	15	

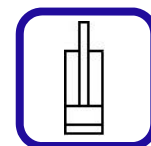

### TFE...MKB (GAR...UK)

### TFE...T-2RS (GAR...UK-2RS)

### TFE...T-2RS MAG

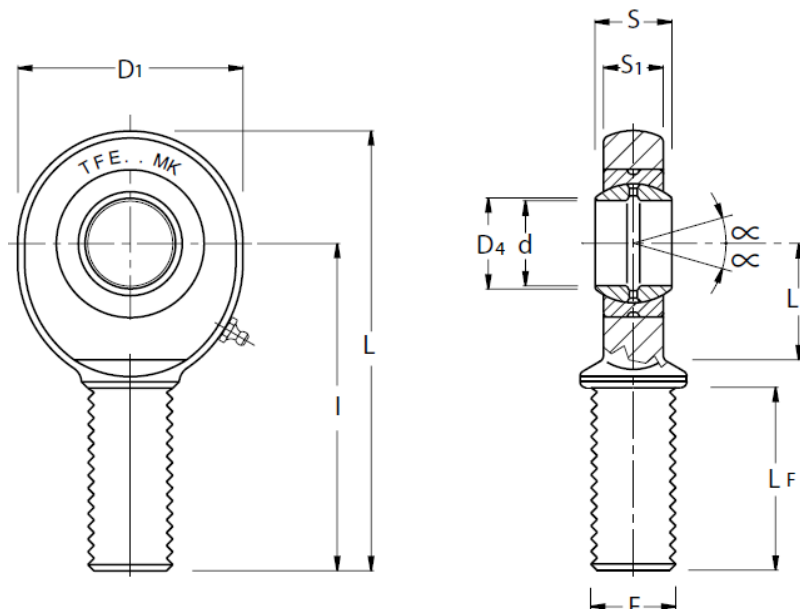

Artikel	d	Toleranz		S	D4	I	D1	S1	L	L1	LF	F	Ladefaktoren		Radiales Spiel	Schwenkwinkel	Gewicht kg	ATP-Artikel-Nr.
		d	S										Dynamisch C	Statisch Co				
		mm																
TFE 6 MKB	6	0 $\pm$ +0.008	0 $\pm$ -0.12	6	8	36	21	4.3	46.5	12	18	M6x1	3.6	8.1	0-0.032	13	0.01	
TFE 8 MKB	8	0 $\pm$ +0.008	0 $\pm$ -0.12	8	10.2	42	24	6	54	14	22	M8x1.25	5.8	12.9	0-0.032	15	0.03	
TFE 10 MKB	10	0 $\pm$ +0.008	0 $\pm$ -0.12	9	13.2	48	29	7	62.5	15	27	M10x1.5	8.6	17.6	0-0.032	12	0.05	
TFE 12 MKB	12	0 $\pm$ +0.008	0 $\pm$ -0.12	10	15	54	34	8	71	19	30	M12x1.75	11.4	24.5	0-0.032	11	0.08	
TFE 15 MKB	15	0 $\pm$ +0.008	0 $\pm$ -0.12	12	18.4	63	40	10	83	20	34	M14x2	17.6	36	0-0.040	8	0.14	
TFE 17 MKB (T-2RS)	17	0 $\pm$ +0.008	0 $\pm$ -0.12	14	20.7	69	46	11	92	23	36	M16x2	22.4	45	0-0.040	10	0.19	
TFE 20 MKB (T-2RS)	20	0 $\pm$ +0.010	0 $\pm$ -0.12	16	24.1	78	53	13	104.5	27.5	43	M20x1.5	31.5	60	0-0.040	9	0.31	256 864 020
TFE 25 MKB (T-2RS)	25	0 $\pm$ +0.010	0 $\pm$ -0.12	20	29.3	94	64	17	126	32	53	M24x2	51	83	0-0.050	7	0.56	
TFE 30 MKB (T-2RS)	30	0 $\pm$ +0.010	0 $\pm$ -0.12	22	34.2	110	73	19	146.5	37	65	M30x2	65.5	110	0-0.050	6	0.89	256 864 030
TFE 35 T-2RS	35	0 $\pm$ +0.012	0 $\pm$ -0.12	25	39.7	140	82	21	181	43	82	M36x3	112	146	0-0.050	6	1.4	
TFE 40 T-2RS	40	0 $\pm$ +0.012	0 $\pm$ -0.12	28	45	150	92	23	196	48	86	M39x3	140	180	0-0.060	7	1.8	
TFE 45 T-2RS	45	0 $\pm$ +0.012	0 $\pm$ -0.12	32	50.7	163	102	27	218	52	94	M42x3	180	240	0-0.060	7	2.6	
TFE 50 T-2RS	50	0 $\pm$ +0.012	0 $\pm$ -0.12	35	56	185	112	30	241	60	106	M45x3	220	290	0-0.060	6	3.4	
TFE 60 T-2RS	60	0 $\pm$ +0.015	0 $\pm$ -0.15	44	66.8	210	135	38	277.5	75	115	M52x3	345	450	0-0.060	6	5.9	
TFE 70 T-2RS	70	0 $\pm$ +0.015	0 $\pm$ -0.15	49	77.8	235	160	42	315	87	125	M56x4	440	610	0-0.072	6	8.2	
TFE 80 T-2RS	80	0 $\pm$ +0.015	0 $\pm$ -0.15	55	89.4	270	180	47	360	100	140	M64x4	570	750	0-0.072	6	12	
TFE 40 T-2RS MAG	40	0 $\pm$ +0.012	0 $\pm$ -0.12	8	45	150	92	23	196	48	86	M42x3	140	180	0-0.060	7	1.85	
TFE 45 T-2RS MAG	45	0 $\pm$ +0.012	0 $\pm$ -0.12	32	50.7	163	102	27	218	52	94	M45x3	180	240	0-0.060	7	2.66	
TFE 50 T-2RS MAG	50	0 $\pm$ +0.012	0 $\pm$ -0.12	35	56	185	112	30	241	60	106	M52x3	220	290	0-0.060	6	3.5	
TFE 60 T-2RS MAG	60	0 $\pm$ +0.015	0 $\pm$ -0.15	44	66.8	210	135	38	277.5	75	115	M60x4	345	450	0-0.060	6	6.02	
TFE 70 T-2RS MAG	70	0 $\pm$ +0.015	0 $\pm$ -0.15	49	77.8	235	160	42	315	87	125	M72x4	440	610	0-0.072	6	8.38	
TFE 80 T-2RS MAG	80	0 $\pm$ +0.015	0 $\pm$ -0.15	55	89.4	270	180	47	360	100	140	M80x4	570	750	0-0.072	6	12.2	

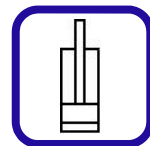

## Anwendungsrichtlinien für Gelenkköpfe

### **Type: TS...C (GK...DO)**

Gleitpaarung:	Stahl / Stahl
Konstruktionsmerkmale:	Gelenkköpfe mit kreisförmiger Anschweissfläche entsprechend DIN 648, Massreihe E, Form C. Gelenkköpfe geschmiedet aus St 52-3 mit Zentrierstift im Schaftboden und 45° Anschweissfase. Gelenklager mittels beidseitiger Ringverstemmung im Gelenkkopf fixiert.
Schmierung:	erforderlich
Geeignet für Belastungsart:	wechselnd
Anwendungsmerkmale:	Gelenkkopf zur wirtschaftlichen Herstellung von Zylinderanlenkelementen. Sowohl auf dem Kolbenstangenende als auch am Zylinderboden einsetzbar.

### **Type: TS...N (GF...DO)**

Gleitpaarung:	Stahl / Stahl
Konstruktionsmerkmale:	Gelenkköpfe mit rechteckiger Anschweissfläche. Gelenkköpfe bis zur Nenngrösse 50 aus geschmiedetem St 52-3, ab Nenngrösse 60 aus gewalztem St 52-3 hergestellt. Gelenklager nach DIN 648, Massreihe E mittels Sprengringen im Gelenkkopf fixiert.
Schmierung:	erforderlich
Geeignet für Belastungsart:	wechselnd
Anwendungsmerkmale:	Gelenkkopf sehr massiver Bauart zum Anschweissen an Hydraulik-Zylinderböden, einsetzbar im Anlagen- und Apparatebau sowie in sonstigen Schweisskonstruktionen. Das Gelenklager ist demontierbar.

### **Type: TAPR...N (GIHR...DO)**

Gleitpaarung:	Stahl / Stahl
Konstruktionsmerkmale:	Hydraulik-Gelenkköpfe mit Innengewinde in gedrungener Bauform – kurzes Gewinde – Gelenkköpfe bis Nenngrösse 50 aus geschmiedetem Stahl, ab Nenngrösse 60 aus Sphäroguss hergestellt. Gelenklager nach DIN 648, Massreihe E ist mittels Sprengringen im Gelenkkopf fixiert.
Schmierung:	erforderlich
Geeignet für Belastungsart:	wechselnd
Anwendungsmerkmale:	Gelenkköpfe mit besonderem Zuschnitt auf den Anwendungsbereich Hydraulikzylinder. Die gedrungene Bauform erlaubt geringste Anlenkabstände bei maximaler Hubausnutzung.

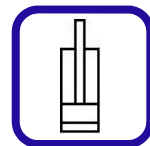
**Type: TAPR...U (GIHR-K...DO)**

Gleitpaarung:	Stahl / Stahl
Konstruktionsmerkmale:	Hydraulik-Gelenkköpfe entsprechend der Reihe TAPR..N, jedoch mit Gewindeklemmeinrichtungen. Klemmung erfolgt über zwei Innensechskantschrauben nach DIN 912-8.8. bzw. -10.9.
Schmierung:	erforderlich
Geeignet für Belastungsart:	wechselnd
Anwendungsmerkmale:	Gelenkköpfe entsprechend der Reihe GIHR..DO, jedoch durch Gewindeklemmeinrichtung auf dem Bolzengewinde zu sichern.

**Type: TAPR...CE / TAPR...S (GIHN-K...LO / GIHO-K...DO)**

Gleitpaarung:	Stahl / Stahl
Konstruktionsmerkmale:	Hydraulik-Gelenkköpfe mit Innengewinde entsprechend DIN 24 338. Gelenkköpfe bis Nenngrosse 50 aus geschmiedetem Stahl ab Nenngrosse 63 aus Sphäroguss hergestellt. Gelenklager ist mittels Sprengringen im Gelenkkopf fixiert. Gewindeklemmeinrichtungen wie bei der Reihe TAPR..U.
Schmierung:	erforderlich
Geeignet für Belastungsart:	wechselnd
Anwendungsmerkmale:	Gelenkköpfe nach DIN 24 338 für Norm-Hydraulikzylinder entsprechend Cetop-Empfehlung RP 58 H; DIN 24 333 DIN 24 336; ISO/DIS 6020 I; ISO/DIS 6022.

**Type: TFI...FK / TFI...FK-2RS (GIR...DO / GIR...DO 2RS)**

Gleitpaarung:	Stahl / Stahl
Konstruktionsmerkmale:	Gelenkkopf DIN 648, Massreihe E, Form B – Innengewindeschaff nachschmierbar über Kegelschmiernippel bzw. Gehäusebohrung Gelenkkopf geschmiedet aus vergütetem Stahl. Ab Nenngrosse 17 auch mit abgedichtetem Lager.
Schmierung:	erforderlich
Geeignet für Belastungsart:	wechselnd
Anwendungsmerkmale:	Gelenkköpfe für turbulente Betriebsverhältnisse( Wechsellast – grosse Schwenkwinkel – stossartige Belastung). Materialschonende Kraftübertragung durch Optimierte Kopfform – schmalbauendes Auge für Kompakte Umgebungs konstruktion – langes Verstellgewinde.

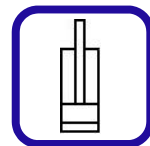
**Type: TFE...MK / TFE...MK-2RS (GAR...DO / GAR...DO 2RS)**

Gleitpaarung:	Stahl / Stahl
Konstruktionsmerkmale:	Gelenkkopf DIN 648, Massreihe E, Form A – Aussengewindeschafft – nachschmierbar über Kegelschmiernippel bzw. Gehäusebohrung. Gelenkkopf geschmiedet aus vergütetem Stahl. Ab Nenngrosse 17 auch mit abgedichtetem Lager.
Schmierung:	erforderlich
Geeignet für Belastungsart:	wechselnd
Anwendungsmerkmale:	Einsatzbereich wie bei der Reihe GIR..UK bzw. GIR..UK-2RS, jedoch mit Aussengewindeschafft.

**Type: TFI...FKB / ...T-2RS (GIR...UK / GIR...UK 2RS)**

Gleitpaarung:	Hartchrom / PTFE-Verbundwerkstoff
Konstruktionsmerkmale:	Gelenkkopf DIN 648, Massreihe E, Form B – Innengewindeschafft Gelenklager wartungsfrei. Gelenkkopf geschmiedet aus vergütetem Stahl.
Schmierung:	nicht erforderlich
Geeignet für Belastungsart:	einseitig
Anwendungsmerkmale:	Gelenkköpfe für ruhige Betriebsverhältnisse ( einseitige Belastung – langsame Bewegung bei kleinen bis mittleren Schwenkwinkeln.) Materialschonende Kraftübertragung durch optimierte Augenform – schmalbauendes Auge für kompakte Umgebungs konstruktion – langes Verstellgewinde.

**Type: TFE...T / 2RS MAG. (GAR...UK / GAR...UK 2RS)**

Gleitpaarung:	Hartchrom / PTFE-Verbundwerkstoff
Konstruktionsmerkmale:	Gelenkkopf DIN 648, Massreihe E, Form A – Aussen-Gewindeschafft. Gelenklager wartungsfrei. Gelenkkopf geschmiedet aus vergütetem Stahl. Ab Nenngrosse 35 auch mit abgedichtetem Lager.
Schmierung:	nicht erforderlich
Geeignet für Belastungsart:	wechselnd
Anwendungsmerkmale:	Gelenkkopf sehr massiver Bauart zum Anschweissen an Hydraulik-Zylinderböden, einsetzbar im Anlagen- und Apparatebau sowie in sonstigen Schweisskonstruktionen. Das Gelenklager ist demontierbar.