

Vickers® Vane Pumps
V Series - Low Noise Vane Pumps

High Performance Intra-vane Pumps
For Industrial Applications

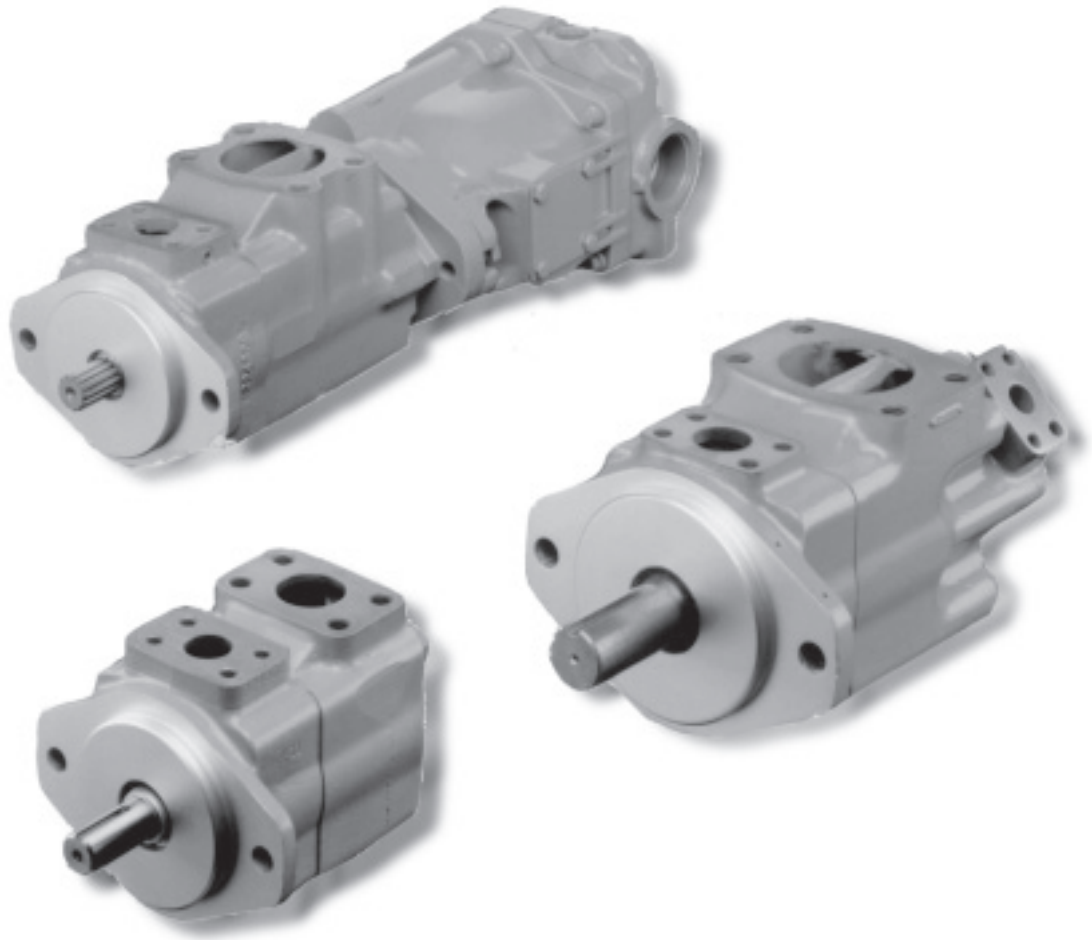

Powering Business Worldwide



EATON

Powering Business Worldwide

The Power of One Eaton

Celebrating **100** YEARS
Ideals that Endure

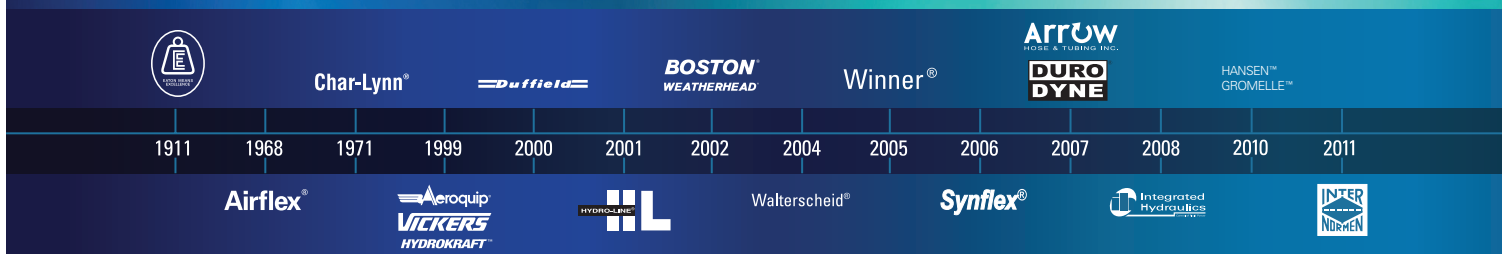

EATON
Powering Business Worldwide

There's a certain energy at Eaton. It's the power of integrating the competencies of some of the world's most respected names to build a brand you can trust to meet every power management need. The energy created supports our commitment to powering business worldwide.

As the world's demand for high-efficiency hydraulic systems for mobile and stationary applications increase, Eaton is helping to solve these challenges more reliably, efficiently, and sustainably. Our goal is simple; to provide unique solutions across a wide range of markets that keep businesses on the leading edge of change. Visit Eaton.com/hydraulics/fusion.

That's the power of One Eaton.

Serving eight key segments - sharing one focus



Alternative Energy

Making energy sources technically practical and economically sound requires the kind of control made possible by high-quality components. When Eaton is on the inside, you will experience the reliable, consistent performance to create and capture energy—making renewable energy an every-day energy.

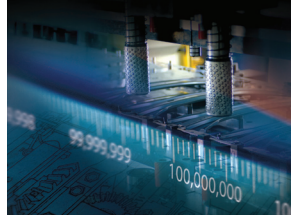

Discrete Manufacturing

Produce at peak efficiency with the superior precision and repeatability of Eaton products. Eaton hydraulic components provide the precise control and consistent operation required for virtually every step in your manufacturing operation. With Eaton, we'll help you redefine the meaning of raw productivity.



Oil & Gas

As the oil & gas industry continues to face further globalization and consolidation, large-scale organizations that can meet your needs in every corner of the world are more difficult to find. At Eaton, our portfolio of products is only surpassed by our tremendous reach.



Processing

Whatever your industry, no matter which processes you manage, Eaton parts and systems help keep you up and running. Our components make equipment more efficient and easier to use, so you get optimal machine performance and maximum productivity.

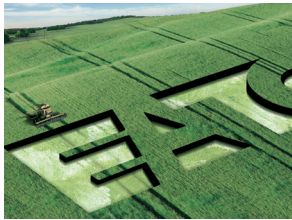

Agriculture & Forestry

There's a reason farming and forestry are called "working the land." These segments involve some of the hardest work and longest hours of any sector in the economy. Your productivity and profitability depend on the way you manage time and tasks.



Commercial Vehicles

Eaton technologies can make your driving operation more successful. Greater comfort and productivity help increase driver retention, while reduced emissions, leaks, and noise improve environmental performance. Increased efficiencies overall mean lower costs and higher net revenue.



Material Handling

Eaton hydraulic systems provide the precise control and consistent operation required for material handling and utility work. With a broad selection of products and solutions built in, Eaton helps make you a master of your domain.



Construction & Mining

When you work on a large scale, even the details are big. You need to trust every part of the equipment that lets you handle construction and mining jobs. For reliable components that deliver consistent performance in extreme conditions, turn to Eaton.

Eaton is a leading diversified power management company

Eaton provides reliable, efficient and safe power management for a growing number of industries.

Understanding and helping our customers succeed

- Listening and understanding to requirements and business drivers
- Delivering solutions with value propositions to solve the critical business needs

Knowing what's important to our customers and integrating that knowledge into the fabric of our business

- ...to deliver innovative, quality products
- ...to respond fast
- ...to provide dedicated customer service and support around the globe

Our strength is global reach with local responsiveness and support

- Customers served in more than 150 countries
- Diverse channels ensure reliable availability and support
- Design and engineering teams provide support for standard products and custom solutions
- Eaton experts offer efficient product and application training

Introduction

Vickers offers the most complete line of hydraulic intravane pumps for industrial applications. A wide variety of single and multiple configurations enables you to select the precise pump or combination best suited for your application.

Your choice of pump is backed by more than 70 years of Vickers engineering and manufacturing skill.

Performance

These cost-effective pumps provide volumetric efficiencies of more than 90% and sound levels as low as 62 dB(A) with operating pressures to 207 bar (3000 psi).

General Description

Intravane pumps provide longer life, increased productivity and application versatility. Extremely low sound levels are compatible with the most demanding industrial applications.

Compact size and ease of service allow maximum equipment design flexibility. Pumps are available in single, double and thru-drive configurations.

Features and Benefits

- High operating pressure capabilities in compact packages provide high power to weight ratios and lower installed costs.
- Low noise characteristics inherent in intravane design enhance operator comfort.
- Twelve vane system provides low amplitude flow pulsations resulting in low system noise characteristics.
- Hydraulic balancing, designed to prevent internally-induced radial shaft and bearing loads, provides long life.
- Double pumps and thru-drive arrangements save installation space and cost by eliminating double shaft extension electric motors or by reducing the number of motors and drive couplings.
- Thru-drive models provide valuable circuit design flexibility, such as having fixed and variable displacement models on a single input drive.
- Sixteen flow displacements and high operating pressure capabilities provide optimum selection and single-source capability for your complete range of flow and pressure requirements.
- Factory tested cartridge kits provide new pump performance upon installation.
- The cartridge kit design offers fast and efficient field serviceability. The cartridge is independent of the drive shaft, allowing for easy change of flow capacity and servicing without removing the pump from its mounting.
- Inlet and outlet ports can be oriented in four different positions relative to each other, providing greater installation flexibility and ease of machine design.

Table of Contents

Model	Maximum Geometric Displacements cm ³ /r (in ³ /r)	Rated Speed r/min	Maximum Pressure bar (psi)	
Single Pumps Installation				
20V	45 (2.8)	1800	207 (3000)	21
25V	67 (4.1)	1800	172 (2500)	22
35V	121 (7.4)	1800	172 (2500)	22
45V	193 (11.7)	1800	172 (2500)	22
Double Pumps Installation				
2520V	67 (4.1) shaft end	1800	172 (2500)	23
	45 (2.8) cover end	1800	207 (3000)	
2525V	67 (4.1) shaft end	1800	172 (2500)	24
	67 (4.1) cover end	1800	172 (2500)	
3520V	121 (7.4) shaft end	1800	172 (2500)	23
	45 (2.8) cover end	1800	207 (3000)	
3525V	121 (7.4) shaft end	1800	172 (2500)	23
	67 (4.1) cover end	1800	172 (2500)	
4520V	193 (11.7) shaft end	1800	172 (2500)	23
	45 (2.8) cover end	1800	207 (3000)	
4525V	193 (11.7) shaft end	1800	172 (2500)	23
	67 (4.1) cover end	1800	172 (2500)	
4535V	193 (11.7) shaft end	1800	172 (2500)	24
	121 (7.4) cover end	1800	172 (2500)	
Thru-Drive Pumps Installation				
25VT	67 (4.1)	1800	172 (2500)	26
35VT	121 (7.4)	1800	172 (2500)	26
45VT	193 (11.7)	1800	172 (2500)	26
Thru-drive Rear Mountings.....				27-30
Performance Data				6
Model Code				7-9
Operating Data				10
Application Data				11
Performance Characteristics				12-20
Installation Data				21-30
Optional Shafts				31-32
ISO Pilot Flange Mounting Options				33
Torque Loading & Drives				34
Foot Mounting Bracket Option				36
Weights & Mounting Options				37
Ordering & Service Information				37

Performance Data Single, Double & Thru-Drive Vane Pumps

Pressure limits, inlet port - bar (psi):

Minimum -0,17 bar (5" Hg) for anti-wear oil
 -0,10 bar (3" Hg) for water containing fluids
 and phosphate esters

Maximum 1,4 bar (20 psi) all fluids

Range 0 to 0,35 bar (0 to 5 psi) all fluids

Maximum continuous pressures in bar (psi), outlet ports

Model	Code	Using anti-wear oil or phosphate ester fluid*	Using water-in-oil emulsions	Using water glycol fluid
20V	2	138 (2000)	69 (1000)	138 (2000)
20V	5,8,11	207 (3000)	69 (1000)	159 (2300)
**20V	12	159 (2300)	69 (1000)	159 (2300)
**20V	14	138 (2000)	69 (1000)	138 (2000)
25V	10,12,14,17,21	172 (2500)	69 (1000)	159 (2300)
25VT	12,14,17,21	172 (2500)	69 (1000)	159 (2300)
25**V	12,14,17,21	172 (2500)	69 (1000)	159 (2300)
**25V	12,14,17,21	172 (2500)	69 (1000)	159 (2300)
35V	25,30,35,38	172 (2500)	69 (1000)	159 (2300)
35VT	25,30,35,38	172 (2500)	69 (1000)	159 (2300)
35**V	25,30,35,38	172 (2500)	69 (1000)	159 (2300)
**35V	25,30,35,38	172 (2500)	69 (1000)	159 (2300)
45V	42,45,50,60	172 (2500)	69 (1000)	159 (2300)
45VT	42, 50, 60	172 (2500)	69 (1000)	159 (2300)
45**V	42, 50, 60	172 (2500)	69 (1000)	159 (2300)

* A transient (peak) pressure 10% over the continuous pressure rating for 0.5 seconds or less duration is allowed.

Speed limits

Minimum speed, all models and fluid combinations 600 rpm

Maximum speed - standard models using anti-wear fluid..... 1800 rpm

Standard models using synthetic and water-in-oil emulsions..... 1200 rpm*

Models using water glycol fluid..... 1500 rpm*

* See Vickers brochure #579.

Single Pump Model Code

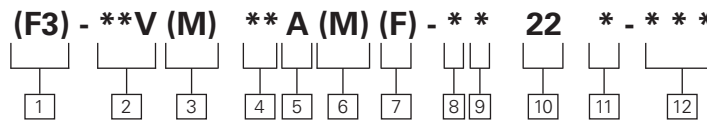

1 F3 - Viton Seals

Omit if not required

2 Series Designation

20V – 7 to 45 cm³/r (0.43 to 2.78 in³/r)

25V – 33 to 67 cm³/r (2.0 to 4.1 in³/r)

35V – 81 to 121 cm³/r (4.9 to 7.4 in³/r)

45V – 138 to 193 cm³/r (8.4 to 11.6 in³/r)

3 Pilot Designation

Omit - Standard pilot

S – SAE per ISO 3019/1 (SAE J744)
(N/A on 20V pump).

M – Metric per ISO 3019/2 100A2HW
codes (N/A on 20V pump).

4 Geometric Displacement

Rated capacity (USgpm) at 1200 rpm,
6,9 bar (100 psi)

Frame Size	Code (USgpm)	cm ³ /r	in ³ /r
20V	2	7	0.43
	5	18	1.10
	8	27	1.67
	9	30	1.85
	11	36	2.22
	12	40	2.47
25V	14	45	2.78
	10	33	2.01
	12	39	2.47
	14	45	2.78
	17	55	3.39
35V	21	67	4.13
	25	81	4.94
	30	97	5.91
	35	112	6.83
45V	38	121	7.37
	42	138	8.41
	45	147	8.95
	50	162	9.85
	60	193	11.75

5 Port Connections

A – SAE 4-bolt flange

6 Port Connection Modifier

Omit – Inch thread port connection
(4-bolt flange).

M – Metric port connection
(4-bolt flange - N/A on 20V)

7 Mounting

Omit - Flange mounting
F – Foot mounting

8 Shafts

Std. Pilot Shafts

Model	Str. Key	HD Str. Key	Spline
20V	1	N/A	151
25V thru 45V	1	86	11

“S” SAE Pilot & “M” Metric ISO Pilot Shafts

Model	Str. Key	HD Str. Key	Metric Str. Key	Spline
25VS - 45VS	202	203	N/A	297
25VM - 45VM	N/A	N/A	292N	N/A

9 Outlet Postions

(Viewed from cover end of pump)

A – Opposite inlet port

B – 90° CCW from inlet

C – Inline with inlet

D – 90° CW from inlet

10 Design

11 Rotation

(Viewed from shaft end of pump)

L – Left hand for counterclockwise

R – Right hand for clockwise

12 Special Suffix

167 – 2-bolt, 5.00” dia. pilot
(25V only - N/A for VS or VM
models)

Note: For options other than listed in the model code, i.e. shafts, ports, displacements and mountings, contact your Vickers representative.

Double Pump Model Code

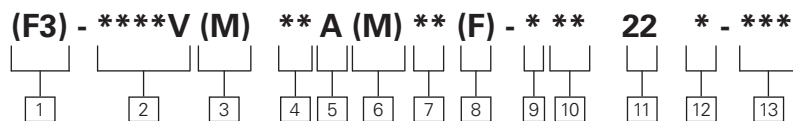

1 F3 - Viton Seals

Omit if not required

2 Series Designation

Displacements cm^3/r (in^3/r)

Model	Shaft End	Cover End
2520V -	33 - 67 (2.0 - 4.1)	7 - 45 (0.45 - 2.8)
2525V -	(2.0 - 4.1)	33 - 67 (0.45 - 2.8)
3520V -	(2.0 - 4.1)	81 - 121 7 - 45
3525V -	(4.9 - 7.4)	81 - 121 33 - 67
4520V -	(4.9 - 7.4)	138 - 193 7 - 45
4525V -	(8.4 - 11.8)	138 - 193 33 - 67
4535V -	(8.4 - 11.8)	138 - 193 81 - 121 (2.0 - 4.1) (8.4 - 11.8)

3 Pilot Designation

Omit - Standard pilot

S – SAE per ISO 3019/1 (SAE J744)
(N/A on 2525V)

M – Metric per ISO 3019/2 100A2HW
(N/A on 2525V)

4 Geometric Displacement - Shaft End Pump

Rated capacity (USgpm) at 1200 rpm,
6,9 bar (100 psi)

Frame Size	Code (USgpm)	cm^3/r	in^3/r
25**V	10	33	2.0
	12	40	2.5
	14	45	2.8
	17	55	3.4
	21	67	4.1
35**V	25	81	4.9
	30	97	5.9
	35	112	6.8
	38	121	7.4
45**V	42	138	8.4
	45	147	9.0
	50	162	9.9
	60	193	11.8

5 Port Connections

A - SAE 4-bolt flange

6 Port Connection Modifier

Omit - Inch thread port connection
(4-bolt flange)

M - Metric port connection
(4-bolt flange)

7 Geometric Displacement - Cover End Pump

Rated capacity (USgpm) at 1200 rpm,
6,9 bar (100 psi)

Frame Size	Code (USgpm)	cm^3/r	in^3/r
**20V	2	7	0.43
	5	18	1.1
	8	27	1.7
	9	30	1.9
	11	36	2.2
	12	40	2.5
**25V	14	45	2.8
	10	33	2.0
	12	40	2.5
	14	45	2.8
	17	55	3.4
4535V	21	67	4.1
	25	81	4.9
	30	97	5.9
	35	112	6.8
	38	121	7.4

8 Mounting

Omit - Flange mounting

F – Foot mounting

9 Shaft

Std. Pilot Shafts

Model	Str. Key	HD Str. Key	Spline
25**V - 45**V	1	N/A	151

"S" SAE Pilot & "M" Metric ISO Pilot Shafts

Model	Str. Key	HD Str. Key	Metric Str. Key	Spline
25**VS - 45**VS	202	203	N/A	297
25**VM - 45**VM	N/A	N/A	292N	N/A

10 Port Orientation

(Viewed from cover end of pump)

All series except 2525V & 4535V
With No. 1 outlet opposite inlet:

AA - No. 2 outlet 135 CCW from inlet

AB - No. 2 outlet 45 CCW from inlet

AC - No. 2 outlet 45 CW from inlet

AD - No. 2 outlet 135 CW from inlet
With No.1 outlet 90 CCW from inlet:

BA - No. 2 outlet 135 CCW from inlet

BB - No. 2 outlet 45 CCW from inlet

BC - No. 2 outlet 45 CW from inlet

BD - No. 2 outlet 135 CW from inlet

With No.1 outlet inline with inlet:

CA - No. 2 outlet 135 CCW from inlet

CB - No. 2 outlet 45 CCW from inlet

CC - No. 2 outlet 45 CW from inlet

CD - No. 2 outlet 135 CW from inlet

With No.1 outlet 90 CW from inlet:

DA - No. 2 outlet 135 CCW from inlet

DB - No. 2 outlet 45 CCW from inlet

DC - No. 2 outlet 45 CW from inlet

DD - No. 2 outlet 135 CW from inlet

Series 2525V & 4535V

With No.1 outlet opposite inlet:

AA - No. 2 outlet opposite inlet

AB - No. 2 outlet 90 CCW from inlet

AC - No. 2 outlet inline with inlet

AD - No. 2 outlet 90 CW from inlet

With No.1 outlet 90 CCW from inlet:

BA - No. 2 outlet opposite inlet

BB - No. 2 outlet 90 CCW from inlet

BC - No. 2 outlet inline with inlet

BD - No. 2 outlet 90 CW from inlet

With No.1 outlet inline with inlet:

CA - No. 2 outlet opposite inlet

CB - No. 2 outlet 90 CCW from inlet

CC - No. 2 outlet inline inlet

CD - No. 2 outlet 90 CW from inlet

With No.1 outlet 90 CW from inlet:

DA - No. 2 outlet opposite inlet

DB - No. 2 outlet 90 CCW from inlet

DC - No. 2 outlet inline with inlet

DD - No. 2 outlet 90 CW from inlet

11 Design

12 Rotation

(Viewed from shaft end of pump)

L – Left hand for counter clockwise

R – Right hand for clockwise

13 Special Suffix

167 – 2-bolt, 5" dia. pilot
(25**V only - N/A for VS or VM models)

Thru-Drive Pump Model Code

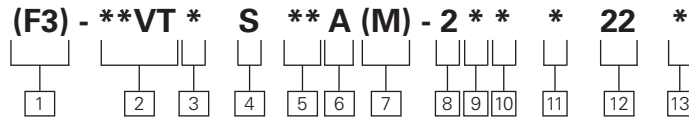

1 F3 - Viton Seals

Omit if not required

2 Series Designation

25VT – 33 to 67 cm³/r (2.0 to 4.1 in³/r)
35VT – 81 to 121 cm³/r (4.9 to 7.4 in³/r)
45VT – 138 to 193 cm³/r (8.4 to 11.8 in³/r)

3 Rear Pump Mounting

SAE (ISO 3019/1) 2-bolt
A – SAE “A”
B – SAE “B”
C – SAE “C” (35VT & 45VT only)
BP – SAE “B” to mount PVE12/19/21 piston pump

4 Pilot Designation

M – Metric per ISO 3019/2 100A2HW
S – Standard pilot per ISO 3019/1 (SAE J744)

5 Geometric Displacement

Rated capacity (USgpm) at 1200 rpm, 6,9 bar (100 psi)

Frame Size	Code (USgpm)	cm ³ /r	in ³ /r
25VT	10	33	2.01
	12	40	2.47
	14	45	2.78
	17	55	3.39
	21	67	4.13
35VT	25	81	4.94
	30	97	5.91
	35	112	6.83
	38	121	7.37
45VT	42	138	8.41
	45	147	8.95
	50	162	9.85
	60	193	11.75

6 Port Connections

A – SAE 4-bolt flange

7 Port Connection Modifier

Omit – Inch thread port connection (4-bolt flange).
M – Metric port connection (4-bolt flange)

8 Thru-Drive Coupling

2 – Coupling with pump (included)

Pump Series	Tail shaft pump Requirements
**VTA	SAE “A” size w/30 involute spline, 9T 16/32 D.P.
**VTB	SAE “B” size w/30 involute spline, 13T 16/32 D.P.
**VTC	SAE “C” size w/30 involute spline, 14T 12/24 D.P.

9 Shaft

Model	SAE Str. Key	ISO Str. Key	SAE Spline	HD Str. Key
25VT	202	292N	297	203
35VT	N/A	292N	297	203
45VT	N/A	292N	297	203

10 Outlet Postions

(Viewed from cover end of pump)
A – Opposite end
B – 90° CCW from inlet
C – Inline with inlet
D – 90° CW from inlet

11 Thru-Drive Adapter Orientation

(Viewed from cover end of pump)
SAE - A Adaptor
A – Rotate 45° CW with respect to pump mounting flange
B – Rotate 45° CCW with respect to pump mounting flange
SAE - B, BP or C adaptor
A – Inline with pump mounting flange
B – Rotate 90 with respect to pump mounting flange

12 Design

13 Rotation

(Viewed form shaft end of pump)
L – Left hand for counterclockwise
R – Right hand for clockwise

Note: For options other than listed in the model code, i.e. shafts, ports, displacements and mountings, contact your Vickers representative.

Operating Data

Sound Levels

Average sound levels are at 138 bar (2000 psi) using SAE 10W (26 cSt) – (128 SUS) oil at 50°C (120°F).

Model	- 1200 rpm	dB(A) 1500 rpm	- 1800 rpm
20V	62	64	66
25V	63	65	67
35V	64	66	69
45V	67	69	71

Sound levels for double pumps are on the average 1 to 3 dB(A) higher when both pumping sections are pressurized.

Sound levels are per NFPA T3.970.12 test standards.

Hydraulic Fluids

Use antiwear industrial hydraulic oils or automotive crankcase oils having letter designations SC, SD, SE or SF with viscosity grades of 32 to 68 cSt at 40° C (140° F). Preferred viscosity at rated speed and pressures:

Minimum	13 cSt (70 SUS)
Maximum	54 cSt (251 SUS)
<hr/>	
Minimum	49°C (120°F)
Maximum	65°C (150°F)

Cold Starts

When operating with SAE 10W oil in the 860 to 54 cSt (4000 to 251 SUS) range, the speed and pressure should be limited to 50% or less of their respective rated values until the system has warmed up. Extreme caution must be used when starting units when fluid viscosities are greater than 860 cSt (4000 SUS). Care should be exercised to warm up the entire system, including remote cylinders and motors.

High Temperature

Viscosities must not be less

than the respective minimum values listed for each series of pumps. Temperatures should not exceed 99° C (210° F) because the life expectancy of cartridge kits and elastomers will decrease.

Water-in-oil Emulsions

Water-in-oil emulsions may be used. However, they require careful selection and monitoring of the fluid. For assistance contact your Vickers representative. Soluble oil-in-water solutions are not recommended.

Synthetic Fire Resistant Fluids

Phosphate esters and their blends with operating viscosity of the petroleum oil described above may be used. These fluids are generally compatible with fluorocarbon and silicone elastomers. Add F3 prefix to the model code for special seals.

For operating conditions exceeding recommendations listed in this section, consult your Vickers representative. For details, refer to Vickers data sheet I-286-S, M-2950-S or GB-B-920, "Hydraulic Fluid and Temperature Recommendations."

Filtration Requirements

For satisfactory service life of components, use full flow filtration to provide fluid cleanliness conforming to ISO code (see next page). Vickers OFP, OFR and OFRS series filters are recommended. Contact your Vickers representative for further filtration advice.

Drive Data

Pumps are assembled for CW or CCW rotation. Right hand or clockwise rotation and left hand or counterclockwise rotation is viewed from the shaft end.

Inlet and outlet ports remain the same regardless of the direction of shaft rotation. Assembly change of internal parts is necessary, when change of shaft rotation is required.

Pump Drive

Direct coaxial drive is recommended. If drives imposing radial shaft loads are considered, please consult your Vickers representative.

Air Bleed

At the time of first-starting, if the pump does not immediately prime, air should be bled from the pump delivery line. This may be accomplished by loosening a connection in the delivery line close to the pump until oil flows – indicating the pump has primed. An air bleed valve is available for this purpose.

CAUTION: – No Case Drain The pump is drained internally into its inlet. System pressure at the pump inlet connection may not exceed 1,4 bar (20 psi).

CAUTION: – Low Outlet Pressure Do not run a pump with the outlet pressure lower than the inlet pressure. This causes operating noise and vane instability.

Start-up Procedure

Make sure the reservoir and circuit are clean and free of dirt/debris prior to filling with hydraulic fluid.

Fill the reservoir with filtered oil and fill to a level sufficient enough to prevent vortexing at suction connection to pump inlet. It is good practice to clean up the system by flushing and filtering using an external slave pump.

Before starting the pump, fill with fluid through one of the ports. This is particu-

larly important if the pump is above the fluid level of the reservoir.

When initially starting the pump, remove all trapped air from the system. This can be accomplished by loosening the pump outlet fittings or connections before starting the pump or by using an air bleed valve. All inlet connections must be tight to prevent air leaks.

Once the pump is started it should prime within a few seconds. If the pump does not prime, check to make sure that there are no restrictions between the reservoir and the inlet to the pump, and that there are no air leaks in the inlet line and connections. Also check to make sure that trapped air can escape at the pump outlet.

After the pump is primed, tighten the loose outlet connections, then operate for five to ten minutes unloaded to remove all trapped air from the circuit.

If reservoir has a sight gage, make sure the fluid is clear – not milky.

Add fluid to the reservoir to bring it up to the proper fill level.

Application Data

Fluid Cleanliness

Proper fluid condition is essential for long and satisfactory life of hydraulic components and systems. Hydraulic fluid must have the correct balance of cleanliness, materials, and additives for protection against wear of components, elevated viscosity, and inclusion of air.

Essential information on the correct methods for treating hydraulic fluid is included in Vickers publication 561 "Vickers Guide to Systemic Contamination Control" available from your local Vickers distributor or by contacting Vickers, Incorporated. Recommendations on filtration and the selection of products to control fluid condition are included in 561.

Recommended cleanliness levels, using petroleum oil under common conditions, are based on the highest fluid pressure

levels in the system and are coded in the chart below. Fluids other than petroleum, severe service cycles, or temperature extremes are cause for adjustment of these cleanliness codes. See Vickers publication 561 for exact details.

Vickers products, as any components, will operate with apparent satisfaction in fluids with higher cleanliness codes than those described. Other manufacturers will often recommend levels above those specified. Experience has shown, however, that life of any hydraulic component is shortened in fluids with higher cleanliness codes than those listed below. These codes have been proven to provide a long, trouble-free service life for the products shown, regardless of the manufacturer.

Product	System Pressure Level bar (psi)		
	<70 (<1000)	70-207 (1000-3000)	207+ (3000+)
Vane Pumps – Fixed	20/18/15	19/17/14	18/16/13
Vane Pumps – Variable	18/16/14	17/15/13	
Piston Pumps – Fixed	19/17/15	18/16/14	17/15/13
Piston Pumps – Variable	18/16/14	17/15/13	16/14/12
Directional Valves	20/18/15	20/18/15	19/17/14
Pressure/Flow Control Valves	19/17/14	19/17/14	19/17/14
CMX Valves	18/16/14	18/16/14	17/15/13
Servo Valves	16/14/11	16/14/11	15/13/10
Proportional Valves	17/15/12	17/15/12	15/13/11
Cylinders	20/18/15	20/18/15	20/18/15
Vane Motors	20/18/15	19/17/14	18/16/13
Axial Piston Motors	19/17/14	18/16/13	17/15/12
Radial Piston Motors	20/18/14	19/17/13	18/16/13

Fluids and Seals

Fluorocarbon seals are available and are suitable for use with phosphate ester type fluids or their blends, water glycol, water-in-oil emulsion fluids and petroleum oil.

20V Performance Characteristics

20V Cartridge Performance

Typical flows at 50° C (120° F), 10W oil (26cSt) - (128 SUS),
0 psi inlet at specified speeds

Codes 5 and 12 Displacement

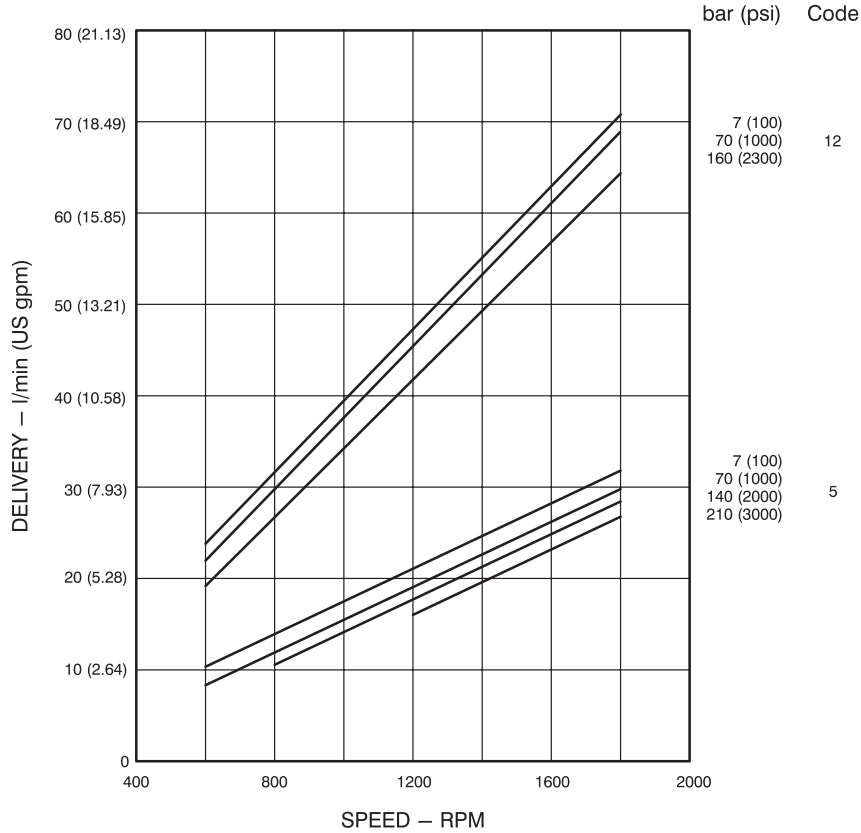

Codes 5 and 12 Input kw (hp)

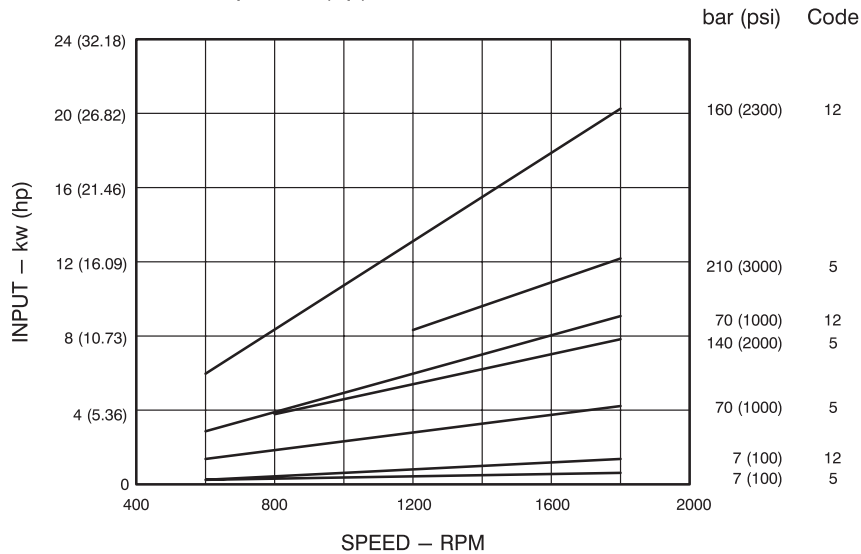

20V Performance Characteristics

20V Cartridge Performance

Typical flows at 50° C (120° F), 10W oil (26cSt) - (128 SUS),
0 psi inlet at specified speeds

Codes 2 and 9 Displacement

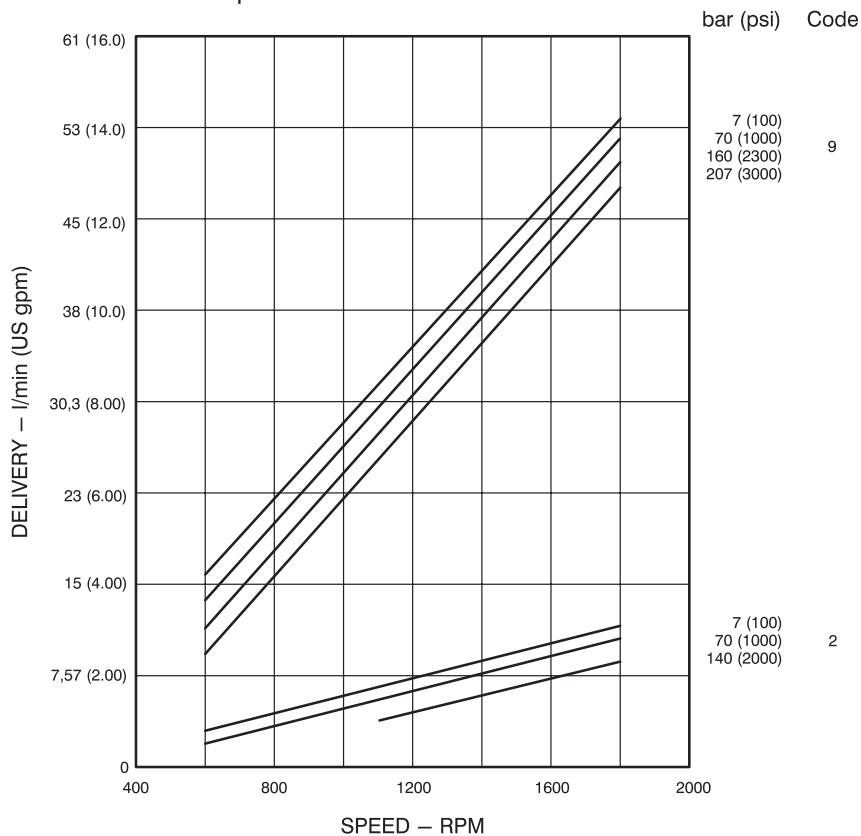

Codes 2 and 9 Input kw (hp)

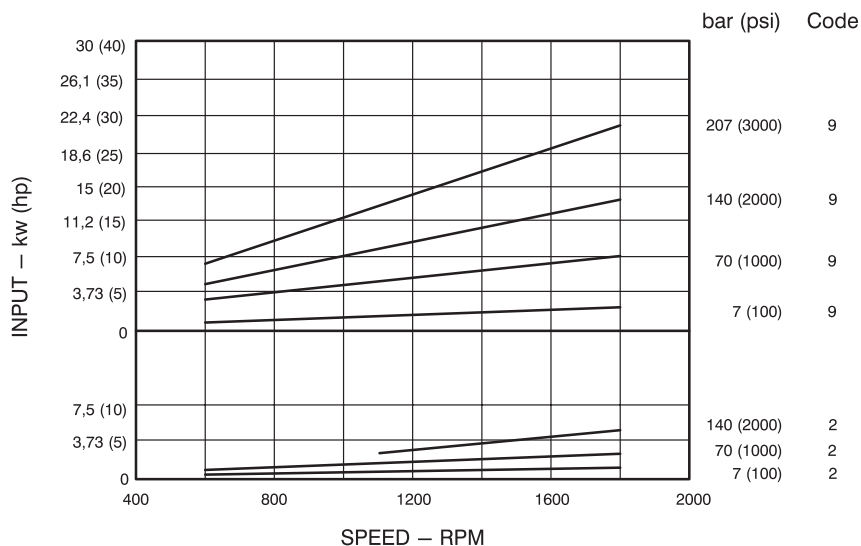

20V Performance Characteristics

Codes 8, 11, and 14 Displacement

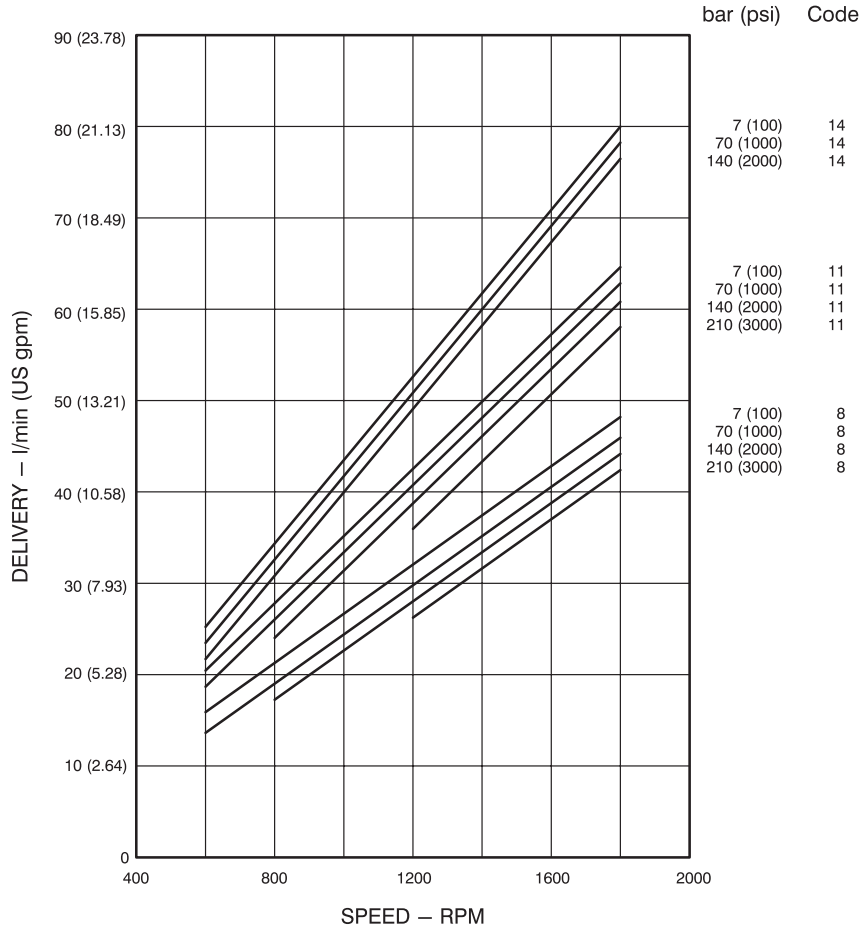

Codes 8, 11, and 14 Input

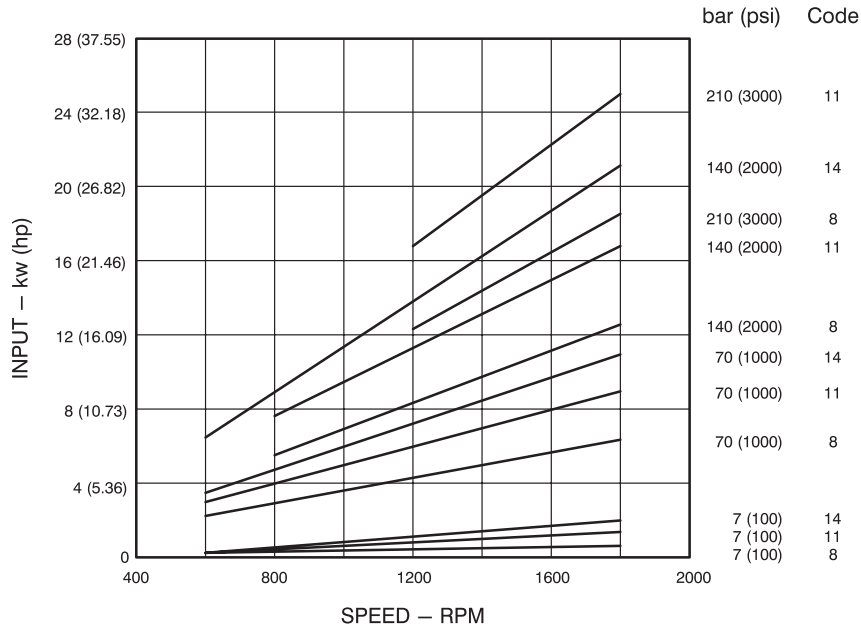

25V(T), 25**V, & **25V Performance Characteristics

25V(T), 25**V, and **25V

Code 10 Displacement

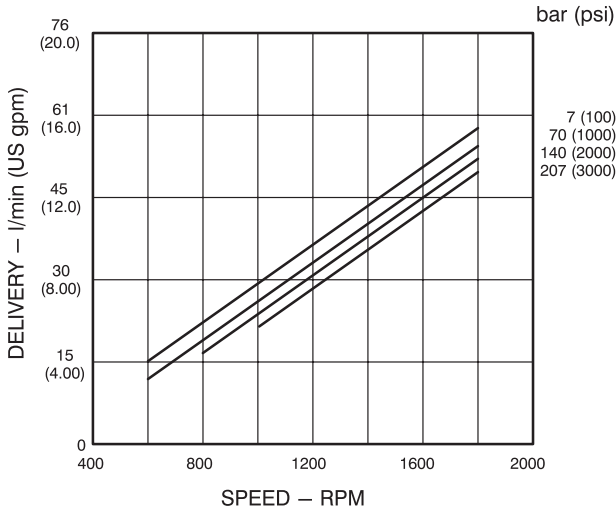

Codes 12 and 17 Displacement

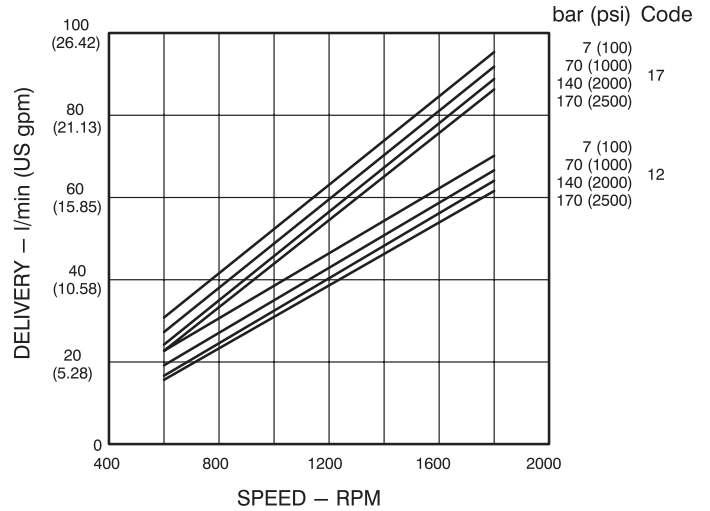

Code 10 Input

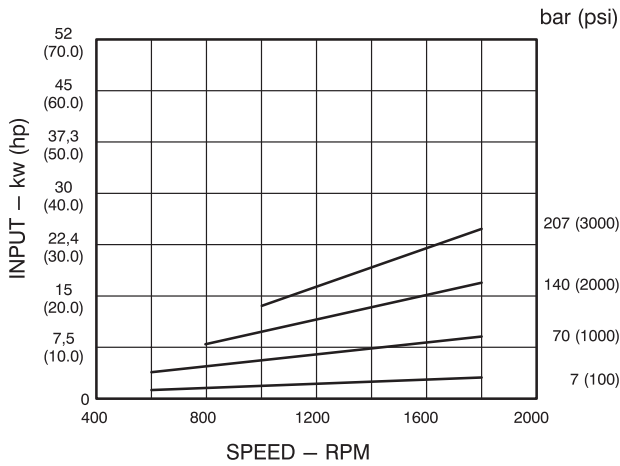

Codes 12 and 17 Input

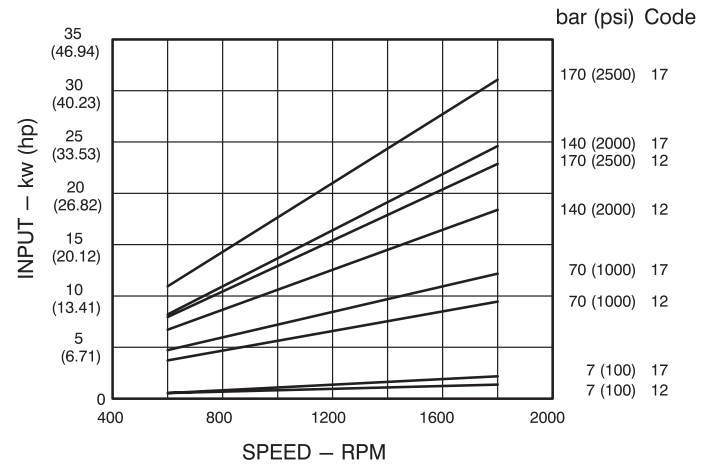

25V(T), 25**V, & **25V

Performance Characteristics

Codes 14 and 21 Displacement

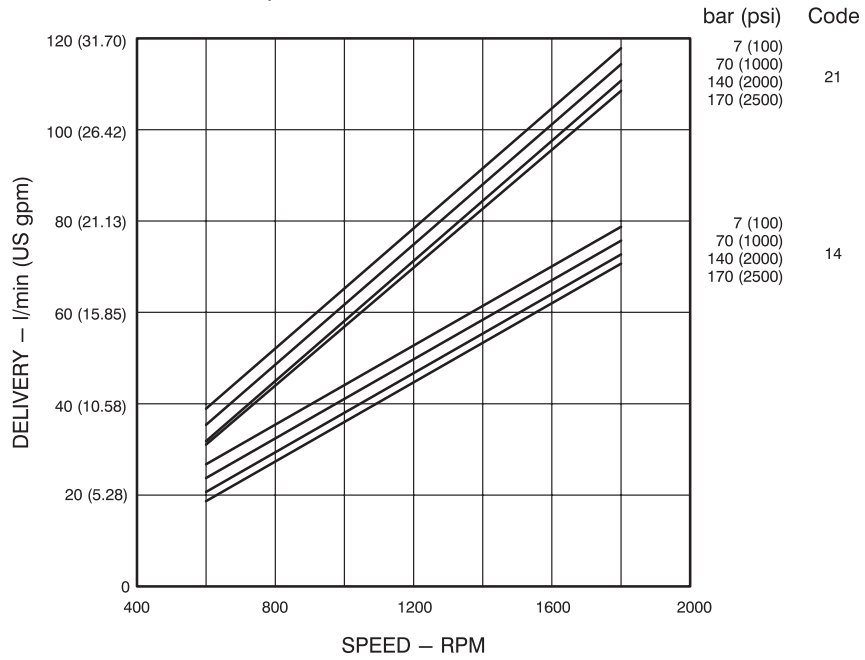

Codes 14 and 21 Input

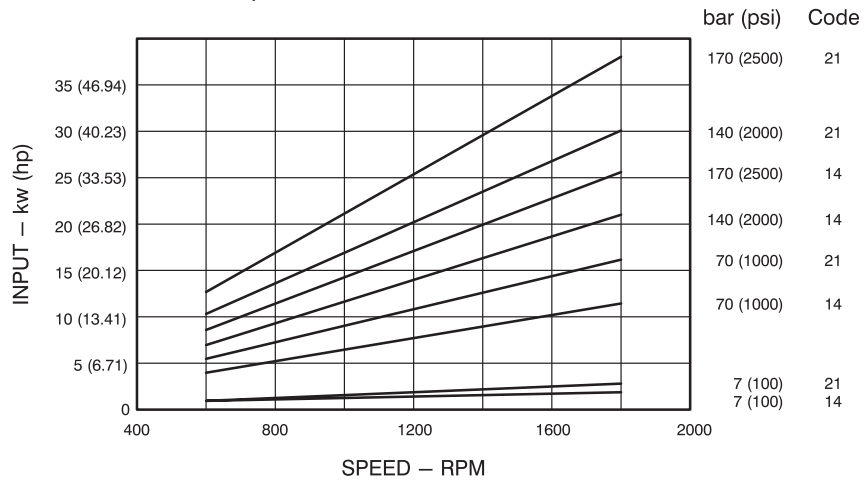

35V(T), 35**V, & **35V

Performance Characteristics

35V(T), 35**V, and **35V

Codes 25 and 35 Displacement

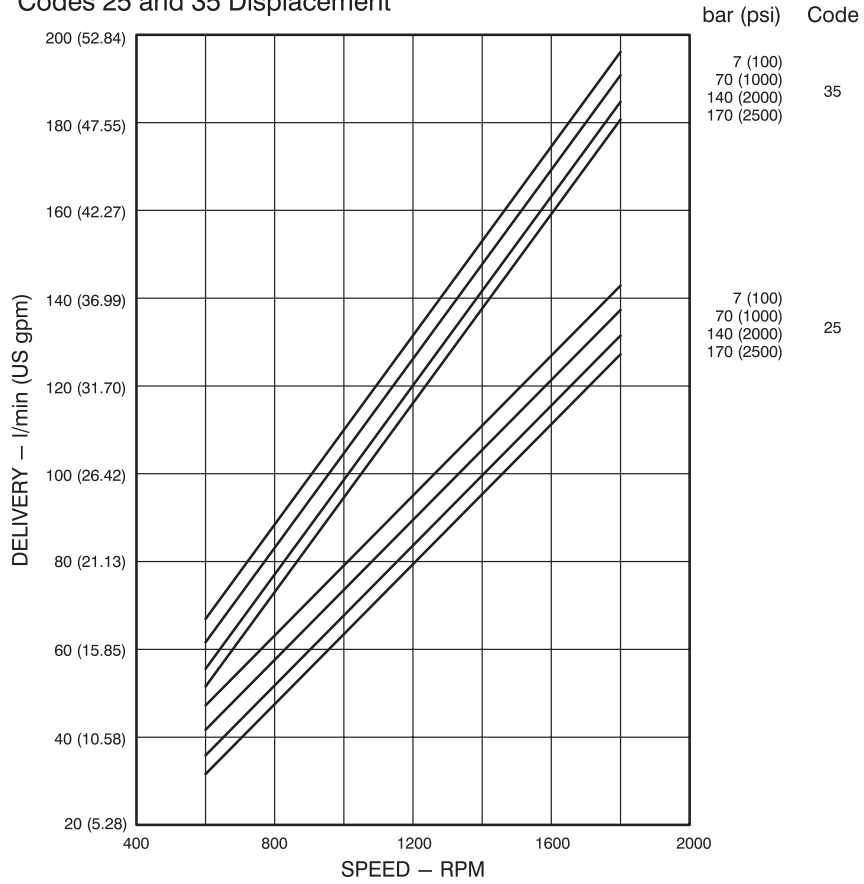

Codes 25 and 35 Input

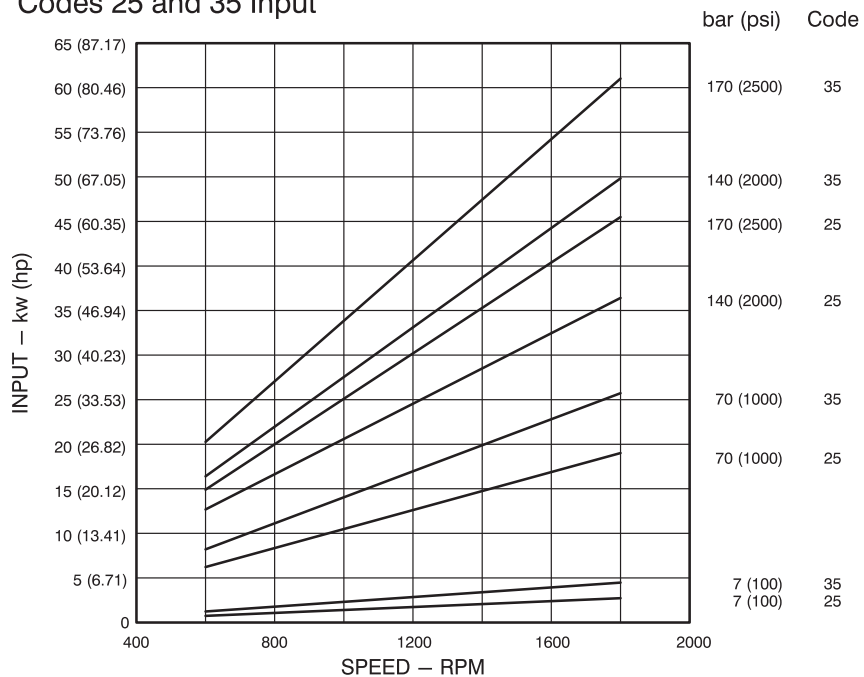

35V(T), 35**V, & **35V

Performance Characteristics

Codes 30 and 38 Displacement

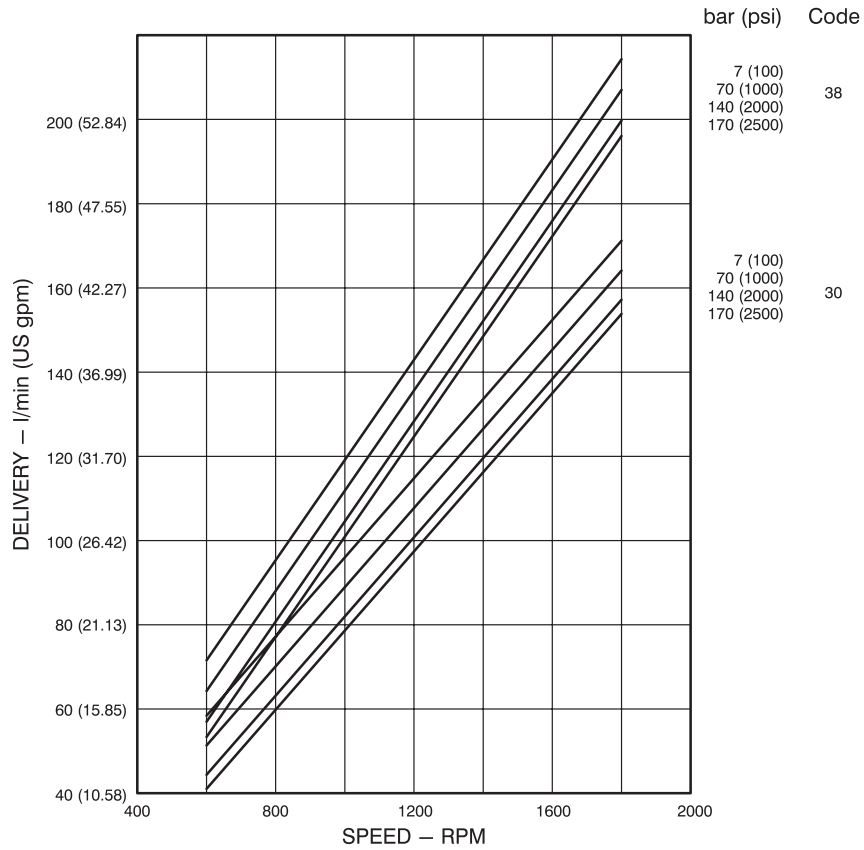

Codes 30 and 38 Input

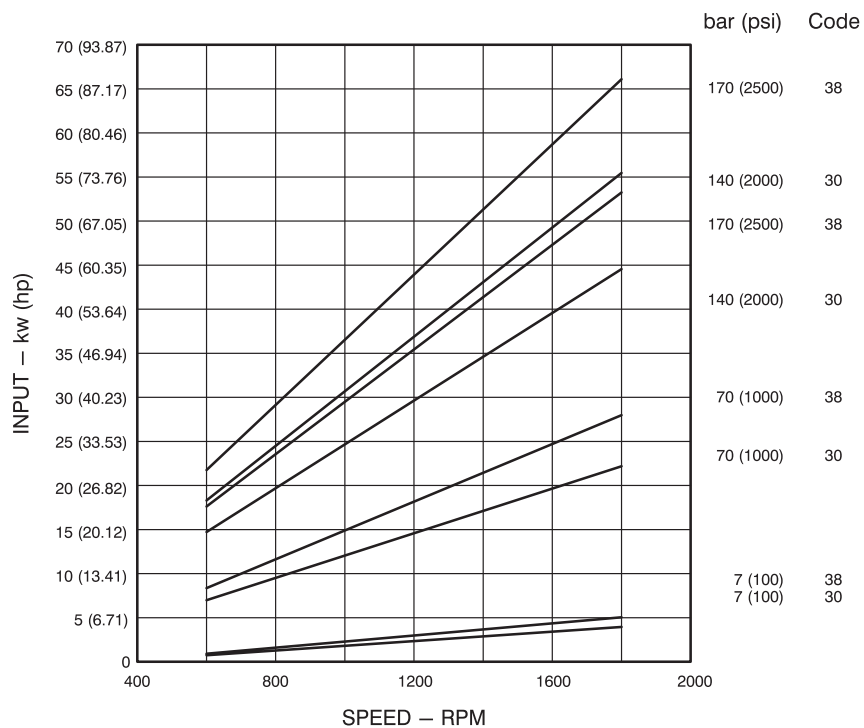

45V(T), 45**V

Performance Characteristics

45V(T) and 45**V

Codes 42 and 60 Displacement

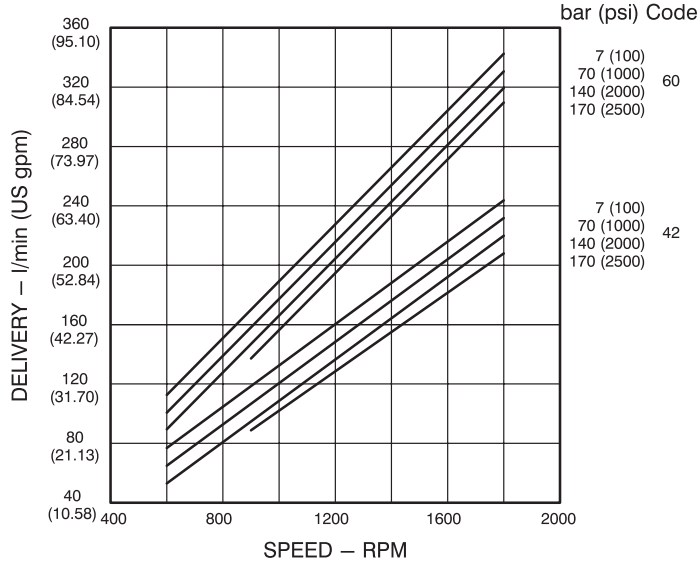

Code 45 Displacement

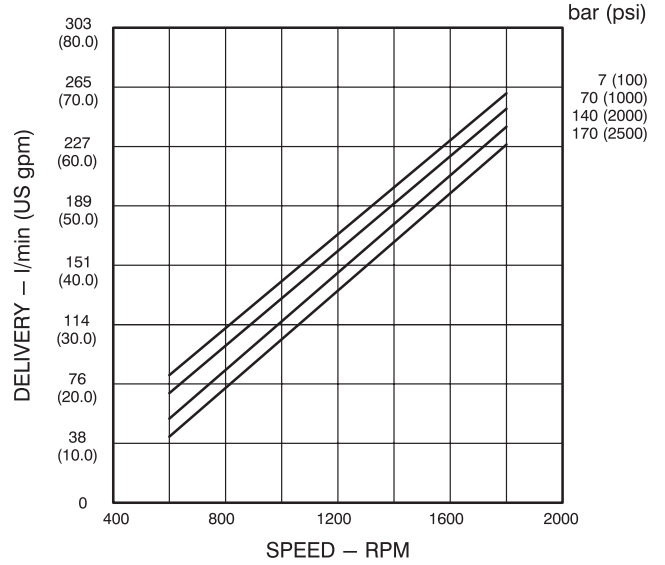

Codes 42 and 60 Input

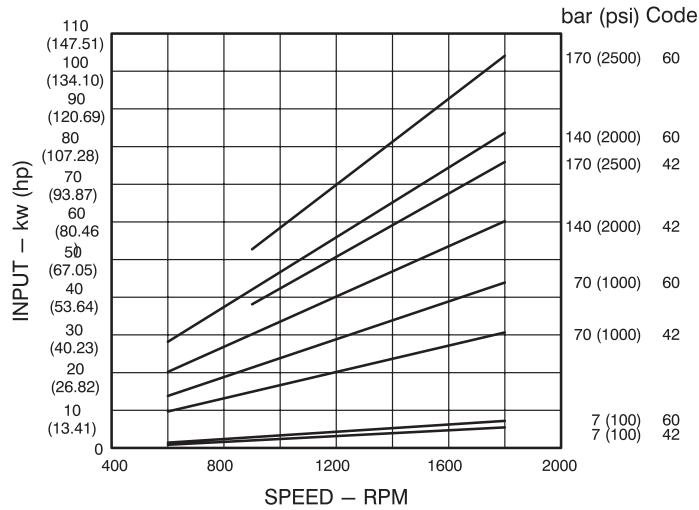

Code 45 Input

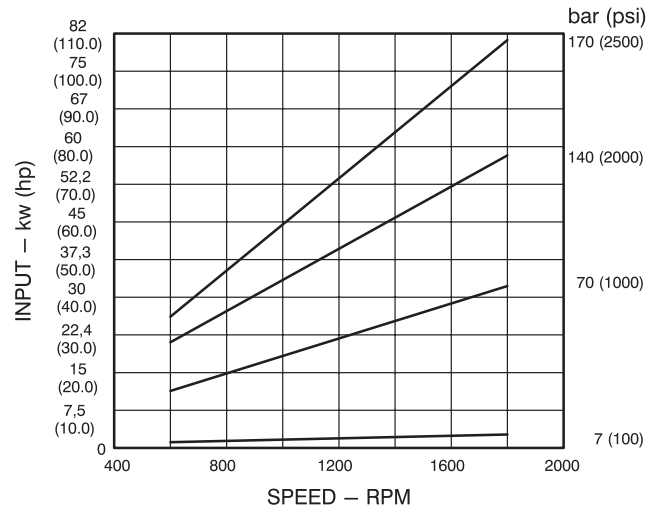

45V(T), 45**V

Performance Characteristics

Code 50 Displacement

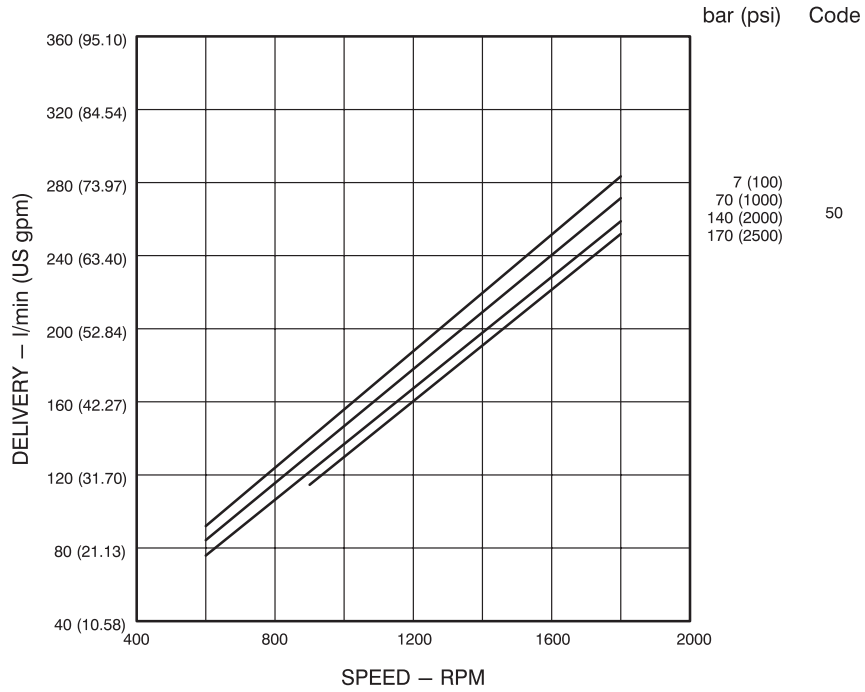

Code 50 Input

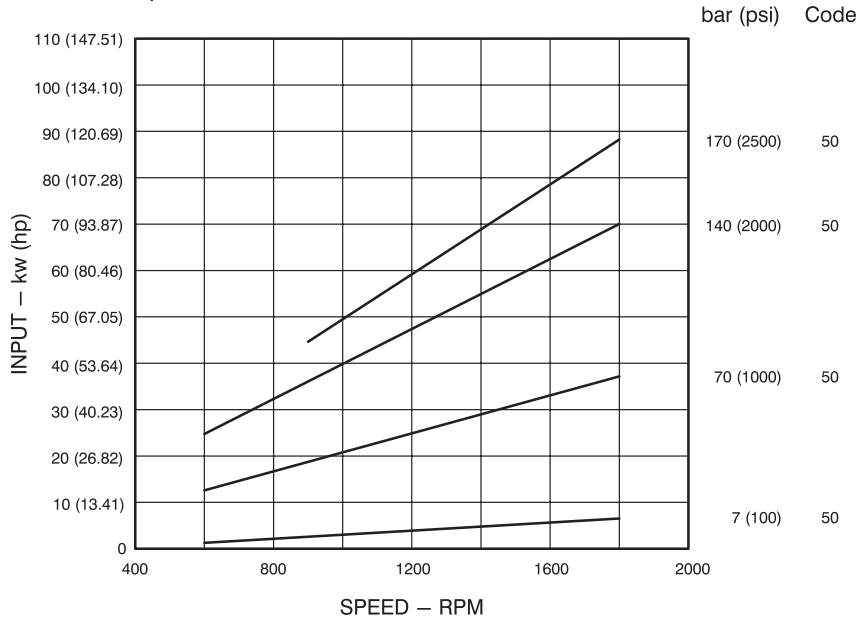

20V Installation Dimensions

20V Series Single Pumps Millimeters (inches)

.375-16 UNC-2B or M10-.750 thd., 4 holes
Uses FL1-6 series flange.

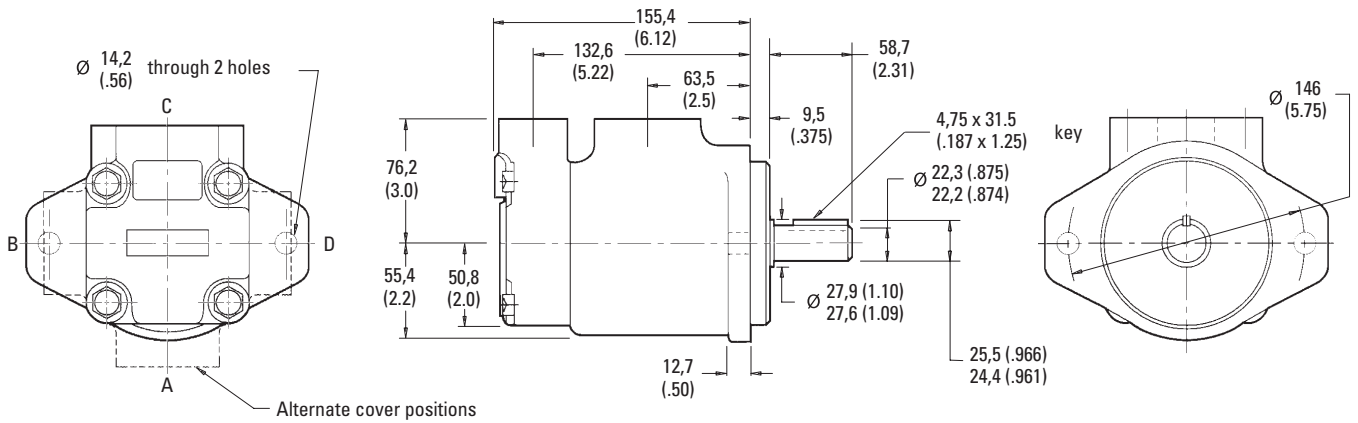
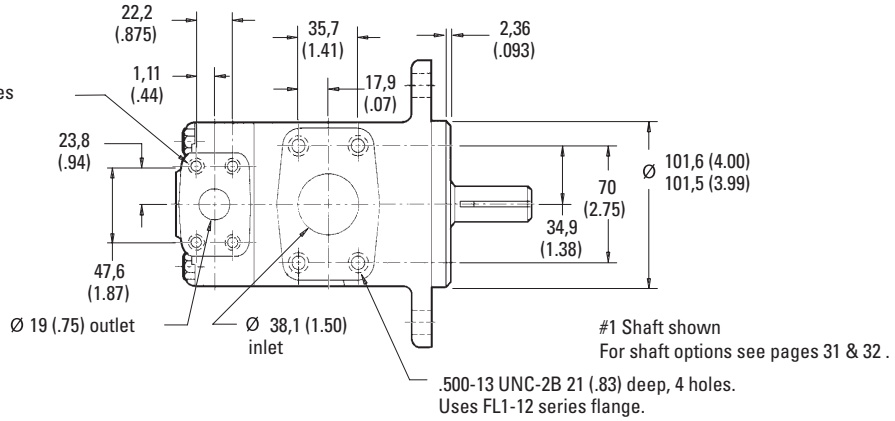

For mounting bracket dimensions see page 36.

25V, 35V, 45V Installation Dimensions

25V, 35V and 45V Single Pumps Millimeters (inches)

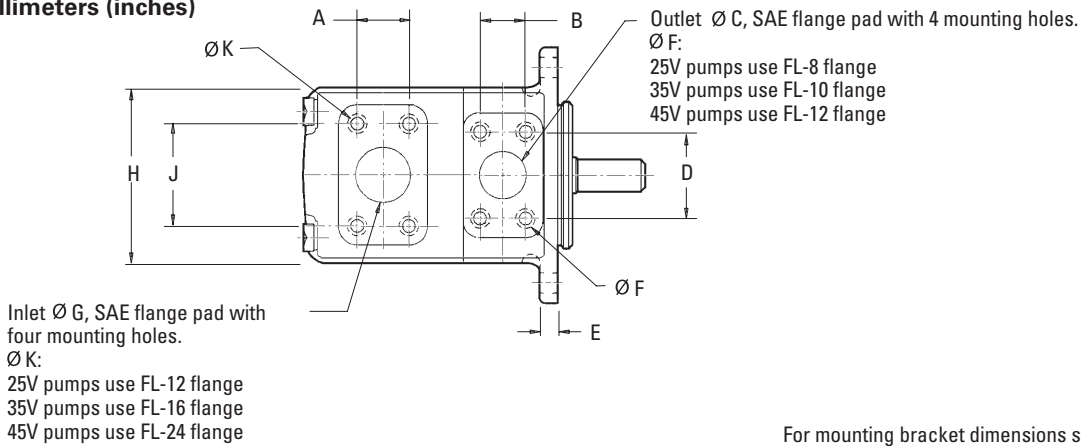

For mounting bracket dimensions see page 36.

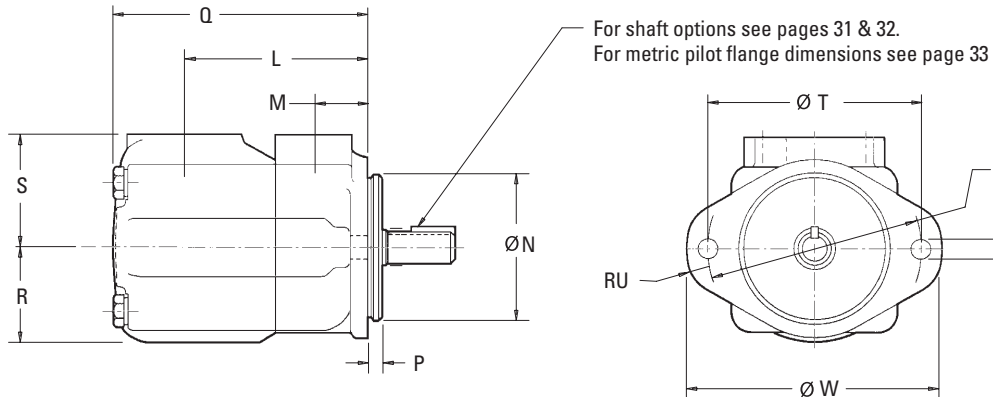

Model	Ø F x full thread depth, 4 holes	Ø K x full thread depth, 4 holes
25V(*)-**AM	M10 x 19,0 (0.75) deep	M12 x 23,8 (0.94) deep
25V(*)-**A	3/8"-16UNC-2B x 19 (0.75) deep	1/2"-13UNC-2B x 23,8 (0.94) deep
35V(*)-**AM	M12 x 22,3 (0.88) deep	M12x22,3 (0.88) deep
35V(*)-**A	0.43"-14UNC-2B x 22,3 (0.88) deep	1/2"-13UNC-2B x 22,3 (0.88) deep
45V(*)-**AM	M12 x 23,8 (0.94) deep	M16 x 30 (1.18) deep
45V(*)-**A	1/2"-13UNC-2B x 23,8 (0.94) deep	5/8"-11UNC-2B x 30 (1.18) deep

Model	A	B	Ø C	D	E	Ø G	H	J	L	L for (**VS & **VM)	M	Ø N	P	P for (**VS)	P for (**VM)
25V	35,7 (1.41)	26,2 (1.03)	25,4 (1.00)	52,4 (2.06)	12,7 (0.50)	38,1 (1.50)	118 (4.62)	69,9 (2.75)	121 (4.76)	149 (5.88)	38,1 (1.50)	101,6 (4.00) 101,5 (3.99)	9,53 (0.38)	9,53 (0.38)	9,25 (.364)
35V	42,9 (1.69)	30,2 (1.19)	31,8 (1.25)	58,7 (2.31)	16 (0.63)	50,8 (2.00)	140 (5.50)	77,8 (3.06)	125,5 (4.94)	133,4 (5.25)	38,1 (1.50)	127,0 (5.00) 126,9 (4.99)	9,53 (0.38)	12,7 (0.50)	9,11 (.359)
45V	61,9 (2.43)	35,7 (1.41)	38,1 (1.50)	69,9 (2.75)	16 (0.63)	76,2 (3.00)	159 (6.25)	106,4 (4.19)	153 (6.03)	164 (6.44)	43 (1.69)	127,0 (5.00) 126,9 (4.99)	12,7 (0.50)	12,7 (0.50)	9,11 (.359)

Model	Q	Q for (**VS)	Q for (**VM)	R	S	Ø T	RU	Ø V	Ø W	Ø X
25V	162,1 (6.38)	171,7 (6.76)	171,7 (6.76)	63,5 (2.50)	76,2 (3.00)	146 (5.75)	14 (0.55)	14,2 (0.56)	175 (6.88)	121 (4.76)
35V	185 (7.28)	193 (7.59)	193 (7.59)	69,9 (2.75)	82,6 (3.25)	181 (7.13)	16 (0.63)	17,5 (0.69)	213 (8.38)	148 (5.83)
45V	216 (8.50)	226 (8.91)	226 (8.91)	82,6 (3.25)	93,7 (3.69)	181 (7.13)	16 (0.63)	17,5 (0.69)	213 (8.38)	148 (5.83)

2520V, 35**V, 452*V Installation Dimensions

2520V, 35**V and 452*V Double Pumps Millimeters (inches)

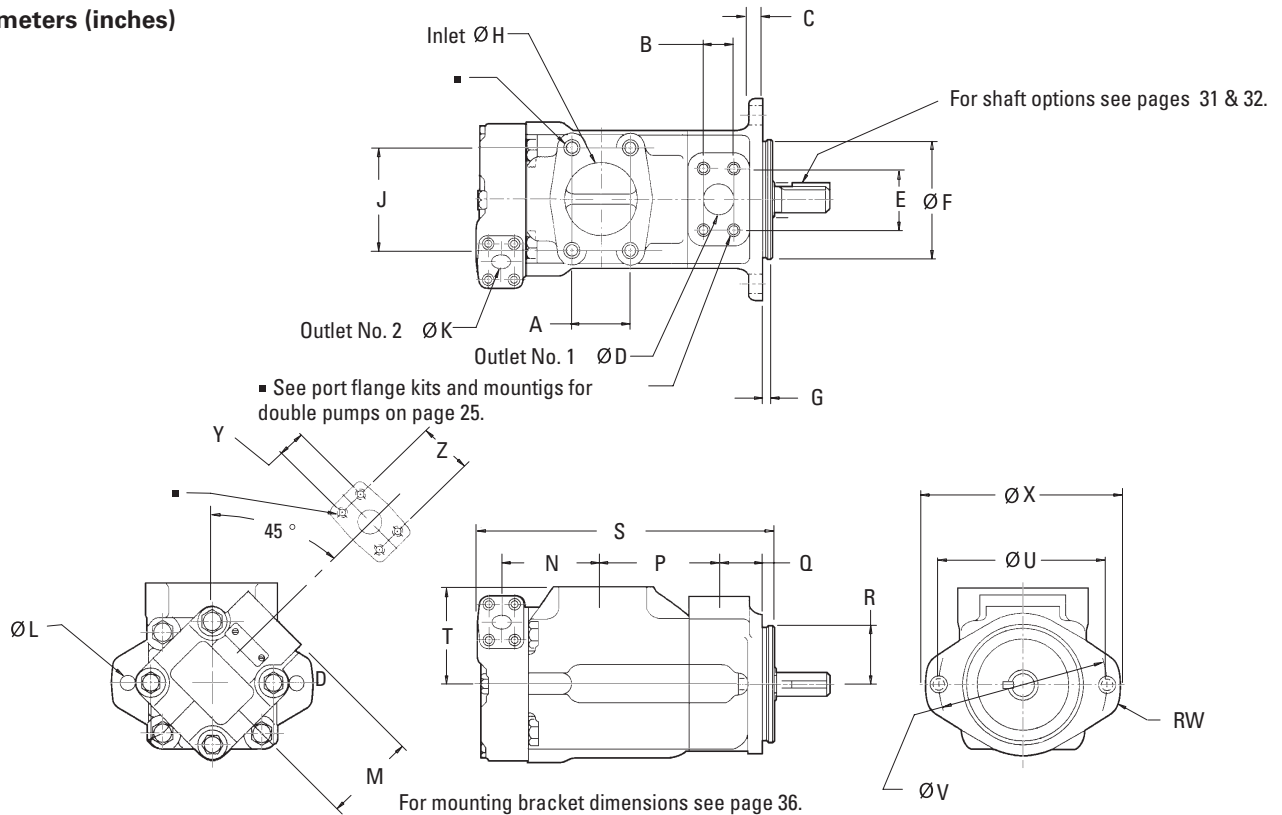

Model	A	B	C	øD▲	E	øF	G	G for (***)VS)	G for (***)VM)	øH▲	J	øK▲	øL	M	N
2520V	50,8 (2.00)	26,2 (1.03)	12,7 (0.50)	25,4 (1.00)	52,4 (2.06)	101,6 (4.0) 101,5 (3.9)	9,53 (0.38)	9,53 (0.38)	9,25 (.364)	63,5 (2.50)	88,9 (3.50)	19,1 (0.75)	14,2 (0.56)	76,2 (3.00)	88,1 (3.47)
3520V	62 (2.44)	30,1 (1.19)	15,9 (0.62)	31,7 (1.25)	58,7 (2.31)	127 (5.00) 126 (4.99)	9,53 (0.38)	12,7 (0.50)	9,12 (.359)	76,2 (3.00)	106,3 (4.19)	19,1 (0,75)	17,5 (0.69)	76,2 (3.00)	99,6 (3.92)
3525V	62 (2.44)	30,1 (1.19)	15,9 (0.62)	31,7 (1.25)	58,7 (2.31)	127 (5.00) 126 (4.99)	9,53 (0.38)	12,7 (0.50)	9,12 (.359)	76,2 (3.00)	106,3 (4.19)	25,4 (1.00)	17,5 (0.69)	74,7 (2.94)	109,5 (4.31)
4520V	69,9 (2.75)	35,7 (1.41)	15,9 (0.62)	38,1 (1.50)	69,9 (2.75)	127 (5.00) 126 (4.99)	12,7 (0.50)	12,7 (0.50)	9,12 (.359)	88,9 (3.50)	120,6 (4.75)	19,1 (0.75)	17,5 (0.69)	76,2 (3.00)	102 (4.72)
4525V	69,9 (2.75)	35,7 (1.41)	15,9 (0.62)	38,1 (1.50)	69,9 (2.75)	127 (5.00) 126 (4.99)	12,7 (0.50)	12,7 (0.50)	9,12 (.359)	88,9 (3.50)	120,6 (4.75)	25,4 (1.00)	17,5 (0.69)	74,7 (2.94)	136 (5.35)

Model	P	P for (***)VS & VM)	Q	R	S	S for (***)VS)	S for (***)VM)	T	øU	øV	RW	øX	Y	Z
2520V	101,6 (4.00)	111,3 (4.38)	38,1 (1.50)	76,2 (3.00)	250 (9.81)	259 (10.2)	259 (10.2)	85,3 (3.38)	146,1 (5.75)	175 (6.88)	14 (0.55)	174,7 (6.88)	22,2 (0.88)	47,6 (1.88)
3520V	114,3 (4.50)	122,2 (4.81)	38,1 (1.50)	82,6 (3.25)	273,3 (10.8)	285 (11.2)	282 (11.1)	88,9 (3.50)	181 (7.13)	148 (5.83)	16 (0.63)	213 (8.38)	22,2 (0.88)	47,6 (1.88)
3525V	114,3 (4.50)	122,2 (4.81)	38,1 (1.50)	82,6 (3.25)	287,3 (9.81)	260 (10.2)	254 (10.0)	88,9 (3.50)	181 (7.13)	148 (5.83)	16 (0.63)	213 (8.38)	26,2 (1.03)	52,4 (2.06)
4520V	119,4 (4.70)	129,7 (5.11)	42,9 (1.69)	93,7 (3.69)	303,5 (11.95)	314 (12.4)	310 (12.2)	102,4 (4.03)	181 (7.13)	148 (5.83)	16 (0.63)	213 (8.38)	22,2 (0.88)	47,6 (1.88)
4525V	119,4 (4.70)	129,7 (5.11)	42,9 (1.69)	93,7 (3.69)	325 (12.8)	336 (13.2)	332 (13.1)	102,4 (4.03)	181 (7.13)	148 (5.83)	16 (0.63)	213 (8.38)	26,2 (1.03)	52,4 (2.06)

▲ Nominal port size, also see next page "port flange kits and mountings for double pumps.

2525V, 4535V

Installation Dimensions

2525V and 4535V Series Double Pumps Millimeters (inches)

■ See port flange kits and mountigs for double pumps on the next page.

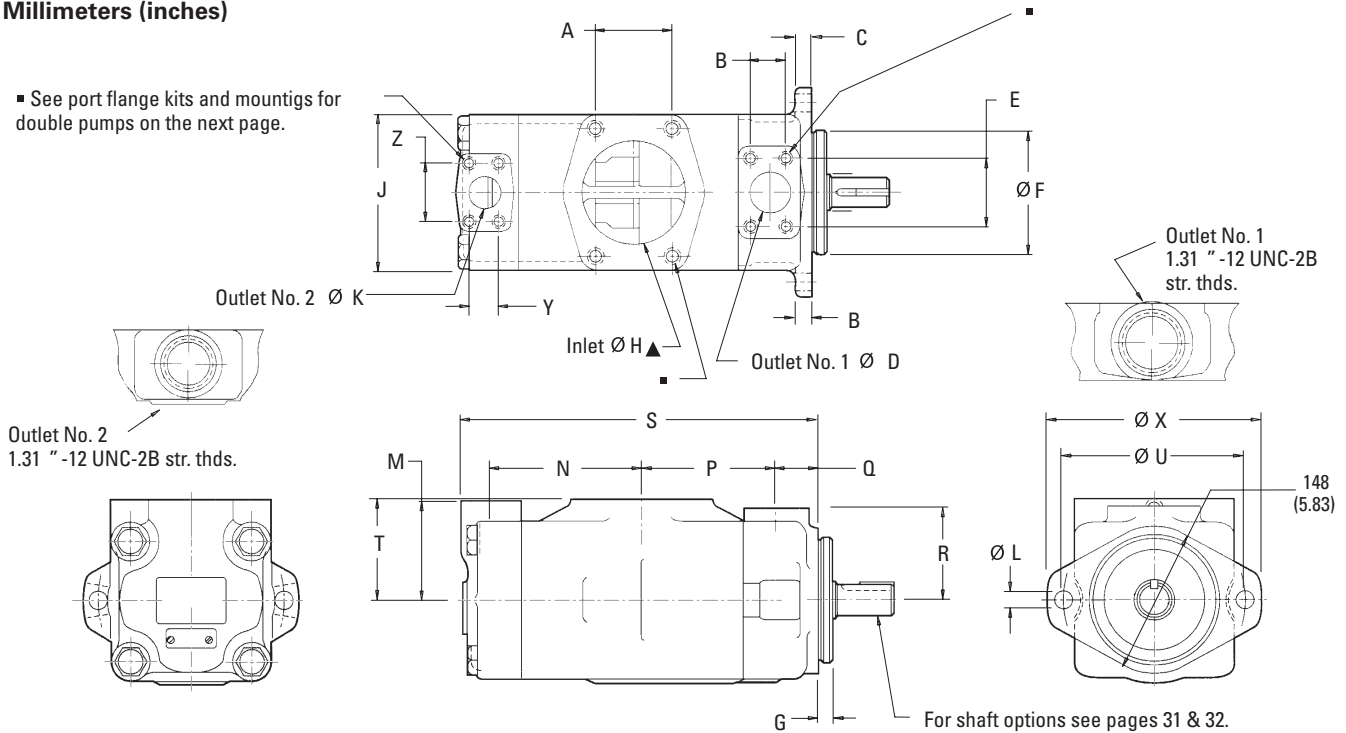

For mounting bracket dimensions see page 36.

▲ Nominal port size, also see next page port flange kits and mountings for double pumps.

Model	A	B	C	\varnothing D▲	E	\varnothing F	G	\varnothing H▲	J	\varnothing K▲	\varnothing L	M	N
2525V	50,8 (2.00)	26,2 (1.03)	12,7 (0.50)	25,4 (1.00)	52,4 (2.06)	101,6 (4.0) 101,5 (3.9)	9,53 (0.38)	63,5 (2.50)	88,9 (3.50)	25,4 (1.00)	14,2 (0.56)	76,2 (3.00)	97,5 (3.84)
4535V	77,8 (3.06)	35,7 (1.41)	15,9 (0.62)	38,1 (1.50)	69,9 (2.75)	127 (5.00) 126 (4.99)	12,7 (0.50)	101,6 (4.00)	130,2 (5.13)	31,7 (1.25)	17,5 (0.69)	101,6 (4.00)	148,3 (5.84)
4535VM							9,12 (.359)						

Model	P	Q	R	S	T	\varnothing U	\varnothing V	RW	\varnothing X	Y	Z
2525V	101,6 (4.00)	38,1 (1.50)	76,2 (3.00)	263 (10.4)	84 (3.31)	146,1 (5.75)	175 (6.88)	14 (0.55)	174,7 (6.88)	26,2 (1.03)	52,4 (2.06)
4535V	133,3 (5.25)	42,9 (1.69)	93,7 (3.69)	353 (13.9)	102,4 (4.03)	181 (7.13)	148 (5.83)	–	213 (8.38)	30,2 (1.19)	58,7 (2.31)
4535VS & 4535VM	144 (5.66)			364 (14.3)							

Port Flange Kits /Mtg for Double Pumps

▪ Port Flange Kits and Mountings for Double Pumps

Pump	Inlet		Outlet No. 1, Shaft end		Outlet No. 2, Rear end	
	Flange Kits	Mounting Bolt Tap & Full Thread Depth	Flange Kits	Mounting Bolt Tap & Full Thread Depth	Flange Kits	Mounting Bolt Tap & Full Thread Depth
2520V-***AM-	N/A from Vickers	M12 x 23,8 (0.94)	N/A from Vickers	M10 x 20,1 (0.79)	N/A from Vickers	M10 x 20,1 (0.79)
2520V-***A-	FL1-20-	.50" - 13UNC-2B x 23,8 (0.94)	FL1-8-	.375" - 16UNC-2B x 20,1 (0.79)	FL1-6	.375" - 16UNC-2B x 20,1 (0.79)
2525V-***AM-	N/A from Vickers	M12 x 23,8 (0.94)	N/A from Vickers	M10 x 20,1 (0.79)	N/A from Vickers	M10 x 20,1 (0.79)
2525V-***A-	FL1-20-	.50" - 13UNC-2B x 23,8 (0.94)	FL1-8-	.375" - 16UNC-2B x 20,1 (0.79)	FL1-8-	.375" - 16UNC-2B x 20,1 (0.79)
3520V-***AM-	N/A from Vickers	M16 x 30,0 (1.18)	N/A from Vickers	M16 x 30,0 (1.18)	N/A from Vickers	M10 x 20,1 (0.79)
3520V-***A-	FL1-24-	.625" - 11UNC-2B x 30,0 (1.18)	FL1-10-	.437" - 14UNC-2B x 30,0 (1.18)	FL1-6-	.375" - 16UNC-2B x 20,1 (0.79)
3525V-***AM-	N/A from Vickers	M16 x 30,0 (1.18)	N/A from Vickers	M16 x 30,0 (1.18)	N/A from Vickers	M10 x 20,1 (0.79)
3525V-***A-	FL1-24-	.625" - 11UNC-2B x 30,0 (1.18)	FL1-10-	.437" - 14UNC-2B x 30,0 (1.18)	FL1-8-	.375" - 16UNC-2B x 20,1 (0.79)
4520V-***AM-	N/A from Vickers	M16 x 30,0 (1.18)	N/A from Vickers	M12 x 23,8 (0.94)	N/A from Vickers	M10 x 20,1 (0.79)
4520V-***A-	FL1-28-	.625" - 11UNC-2B x 30,0 (1.18)	FL1-12-	.50" - 13UNC-2B x 23,8 (0.94)	FL1-6-	.375" - 16UNC-2B x 20,1 (0.79)
4525V-***AM-	N/A from Vickers	M16 x 30,0 (1.18)	N/A from Vickers	M12 x 23,8 (0.94)	N/A from Vickers	M10 x 20,1 (0.79)
4525V-***A-	FL1-28-	.625" - 11UNC-2B x 30,0 (1.18)	FL1-12-	.50" - 13UNC-2B x 23,8 (0.94)	FL1-8-	.375" - 16UNC-2B x 20,1 (0.79)
4535V-***AM-	N/A from Vickers	M16 x 30,0 (1.18)	N/A from Vickers	M12 x 23,8 (0.94)	N/A from Vickers	M10 x 20,1 (0.79)
4535V-***A-	FL1-32-	.625" - 11UNC-2B x 30,0 (1.18)	FL1-12-	.50" - 13UNC-2B x 23,8 (0.94)	FL1-10-	.437" - 14UNC-2B x 30,0 (1.18)

**VT Thru Drives Installation Dimensions

**VT Series Thru-Drives

For metric pilot flanges see page 33.

Conforms to SAE J744
Flange code 101-2 for 25VT
Flange code 127-2 for 35VT & 45VT

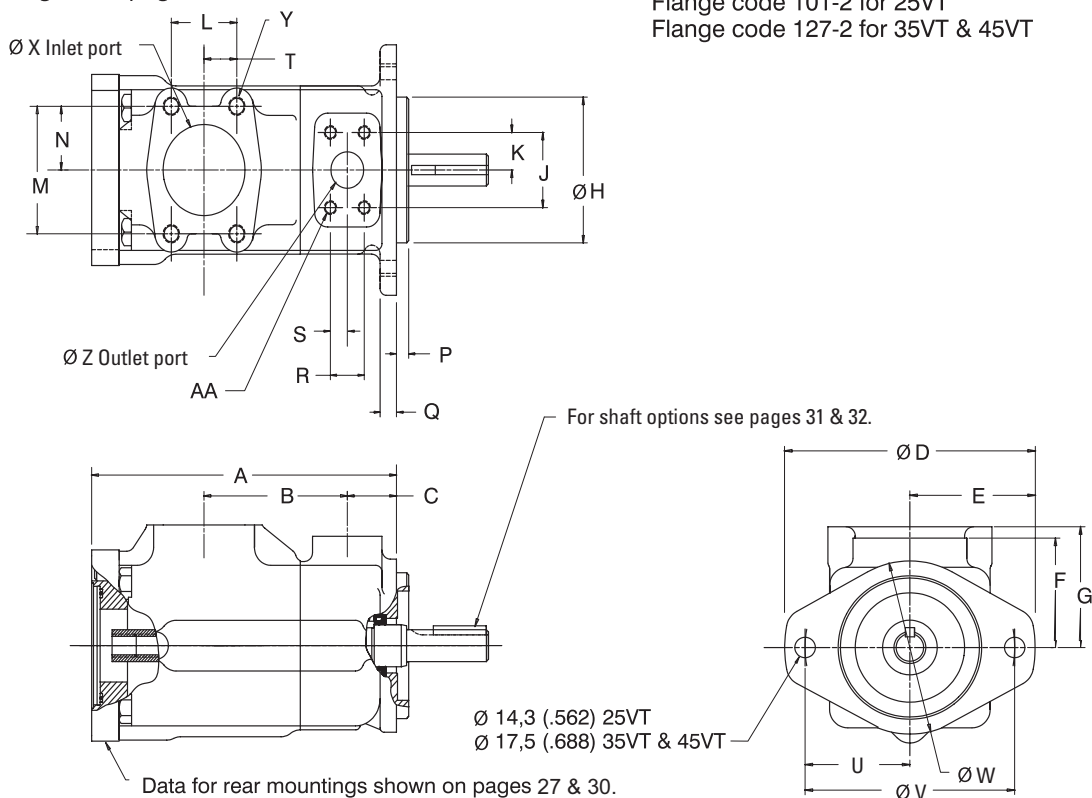

Model	A	B	C	øD	E	F	G	øH	J	K	L	M	N
25VT	See page .	111,1 (4.38)	38,1 (1.50)	174,8 (6.88)	87,4 (3.44)	76,2 (3.00)	84,1 (3.31)	101,6 (4.00) 101,5 (3.99)	52,4 (2.06)	26,2 (1.03)	50,8 (2.00)	88,9 (3.50)	44,5 (1.75)
35VT	See page .	122 (4.81)	38,1 (1.50)	213 (8.38)	106,2 (4.18)	82,6 (3.30)	88,9 (3.50)	127,0 (5.00) 126,9 (4.99)	58,7 (2.31)	29,4 (1.16)	61,9 (2.44)	106,4 (4.19)	53,2 (2.09)
45VT	See page .	129,9 (5.11)	42,9 (1.69)	213 (8.38)	106,2 (4.18)	93,7 (3.69)	102,3 (4.03)	127,0 (5.00) 126,9 (4.99)	69,9 (2.75)	34,9 (1.38)	69,9 (2.75)	120,7 (4.75)	60,3 (2.38)

Model	P	Q	R	S	T	U	øV	øW	øX	Y	øZ	AA
25VT	9,52 (0.375)	12,7 (0.50)	26,2 (1.03)	13,1 (0.52)	25,4 (1.00)	73 (2.88)	146 (5.75)	120,6 (4.75)	63,5 (2.50)	.500-13 UNC-2B or M12 thd. 23,8 (.938) deep 4 holes	25,4 (1.00)	.375-16 UNC-2B or M16 thd. 20,1 (0.79) deep 4 holes
35VT	12,5 (0.49)	15,7 (0.62)	30,2 (1.19)	15,1 (0.59)	30,9 (1.22)	90,5 (3.56)	180,9 (7.13)	147,6 (5.81)	76,2 (3.00)	.625-11 UNC-2B or M16 thd. 30,0 (1.18) deep 4 holes	31,8 (1.25)	.437-14 UNC-2B or M16 thd. 30,0 (1.18) deep 4 holes
45VT	12,5 (0.49)	15,7 (0.62)	35,7 (1.41)	17,9 (0.70)	35,9 (1.38)	90,5 (3.56)	181 (7.13)	147,6 (5.81)	88,9 (3.50)	.625-11 UNC-2B or M16 thd. 30,0 (1.18) deep 4 holes	38,1 (1.50)	.500-13 UNC-2B or M12 thd. 22,2 (.875) deep 4 holes

**VT Thru-Drive Rear Mountings Installation Dimensions

**VT Thru-Drive Rear Mountings "A" Rear Mounting

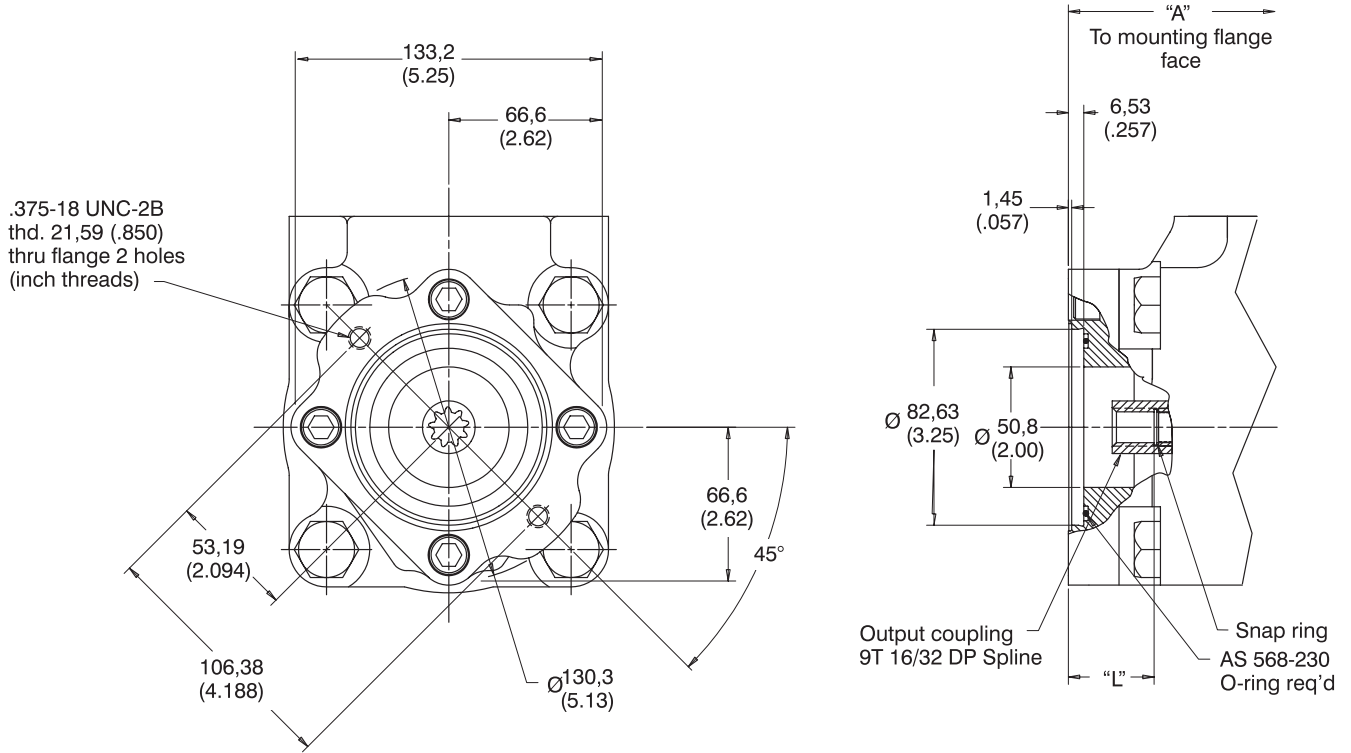

Dimension "A"			Dimension "L"*
Pump Model	**VTAS Models	**VTAM Models	
			32,6/31,0 (1.28/1.22)
			33,0 (1.30)
			Maximum
25VTA	236,5 (9.3)	236,5 (9.3)	32,6/31,0 (1.28/1.22)
			35,6 (1.40)
			Maximum
35VTA	259,1 (10.2)	259,1 (10.2)	32,6/31,0 (1.28/1.22)
			35,3 (1.39)
			Maximum
45VTA	291,6 (11.5)	321,8 (12.7)	

* Caution: Dimension "L" is important and must be observed.

NOTE: This unit **accepts** a hydraulic pump which conforms to flange and shaft codes specified in ISO 3019/1 (SAE J744 Jul88).

Flange Code	Shaft Code	SAE J744C (Ref)
82-2	16-4	A

**VTA

The following Vickers shaft selection will comply with the above:

Rear Pump Model	Shaft
V10 Vane pump	11
V20 Vane pump	62
PVB5/6 Piston pump	S124

**VT Thru-Drive Rear Mountings Installation Dimensions

**VT Thru-Drive Rear Mountings "B" Rear Mounting

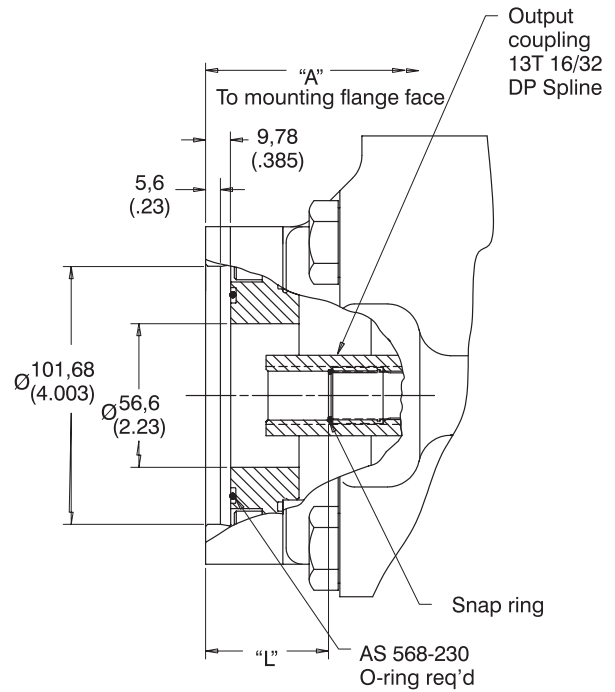
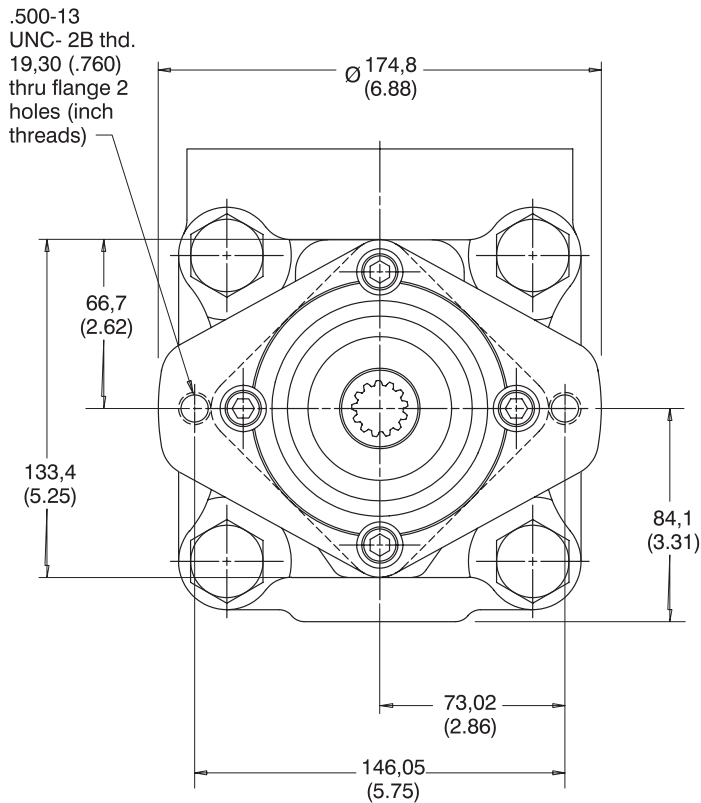

Dimension "A"

Pump Model	**VTBS Models	**VTBM Models	Dimension "L"*
			42,3/39,9 (1.67/1.57)
			45,2 (1.78)
25VTB	245,8 (9.67)	245,8 (9.67)	Maximum
			42,3/39,9 (1.67/1.57)
			46,7 (1.84)
35VTB	268,2 (10.56)	268,2 (10.56)	Maximum
			42,3/39,9 (1.67/1.57)
			46,2 (1.82)
45VTB	300,7 (11.84)	331,0 (13.03)	Maximum

* Caution: Dimension "L" is important and must be observed.

NOTE: This unit **accepts** a hydraulic pump which conforms to flange and shaft codes specified in ISO 3019/1 (SAE J744 Jul88).

Flange Code	Shaft Code	SAE J744C (Ref)
101-2	22-4	B

**VTB

The following Vickers shaft selection will comply with the above:

Rear Pump Model	Shaft
PVB10/15 Piston pump	S124
V2010/2020 Double pump	11
20V Vane pump	151
25V Vane pump	11
2520V Double pump	11

**VT Thru-Drive Rear Mountings Installation Dimensions

**VT Thru-Drive Rear Mountings "BP" Rear Mounting

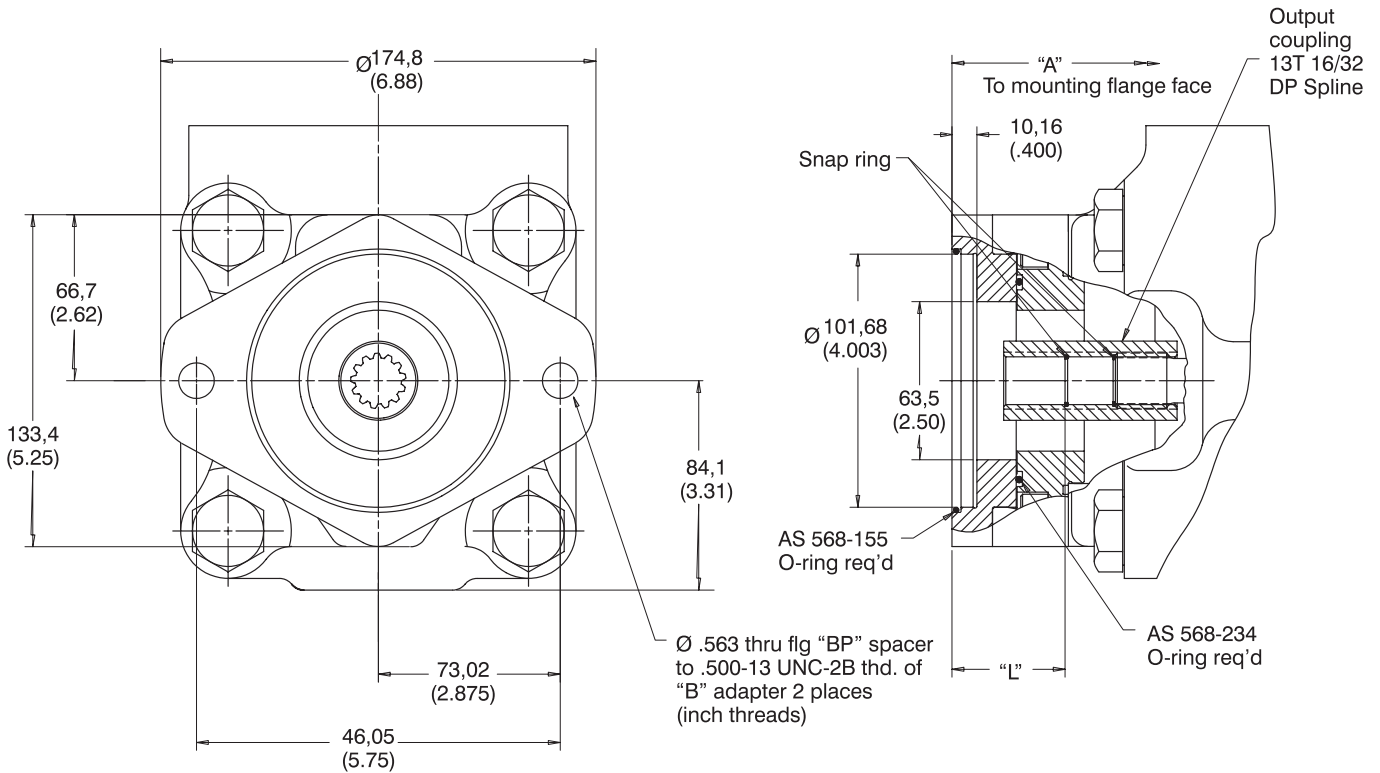

Dimension "A"			Dimension "L"*
Pump Model	**VTBPS	**VTBPM	
25VTBP	261,9 (10,31)	261,9 (10,31)	45,6/43,2 (1,80/1.70) Not SAE std.
35VTBP	284,5 (11,20)	284,5 (11,20)	45,6/43,2 (1,80/1.70) Not SAE std.
45VTBP	317,0 (12,48)	347,2 (13,67)	45,6/43,2 (1,80/1.70) Not SAE std.

* Caution: Dimension "L" is important and must be observed.

NOTE: These units accept a Vickers pump as below which conforms to flange code 101-2 in ISO 3019/1 (SAE J744C Ju188) and has a Vickers type 9 shaft

**VTBP

The following Vickers shaft selection will comply with the above:

Rear Pump Model	Shaft
PVE12/19/21 Piston pump	9

**VT Thru Drive Rear Mountings Installation Dimensions

**VT Thru-Drive Rear Mountings "C" Rear Mounting

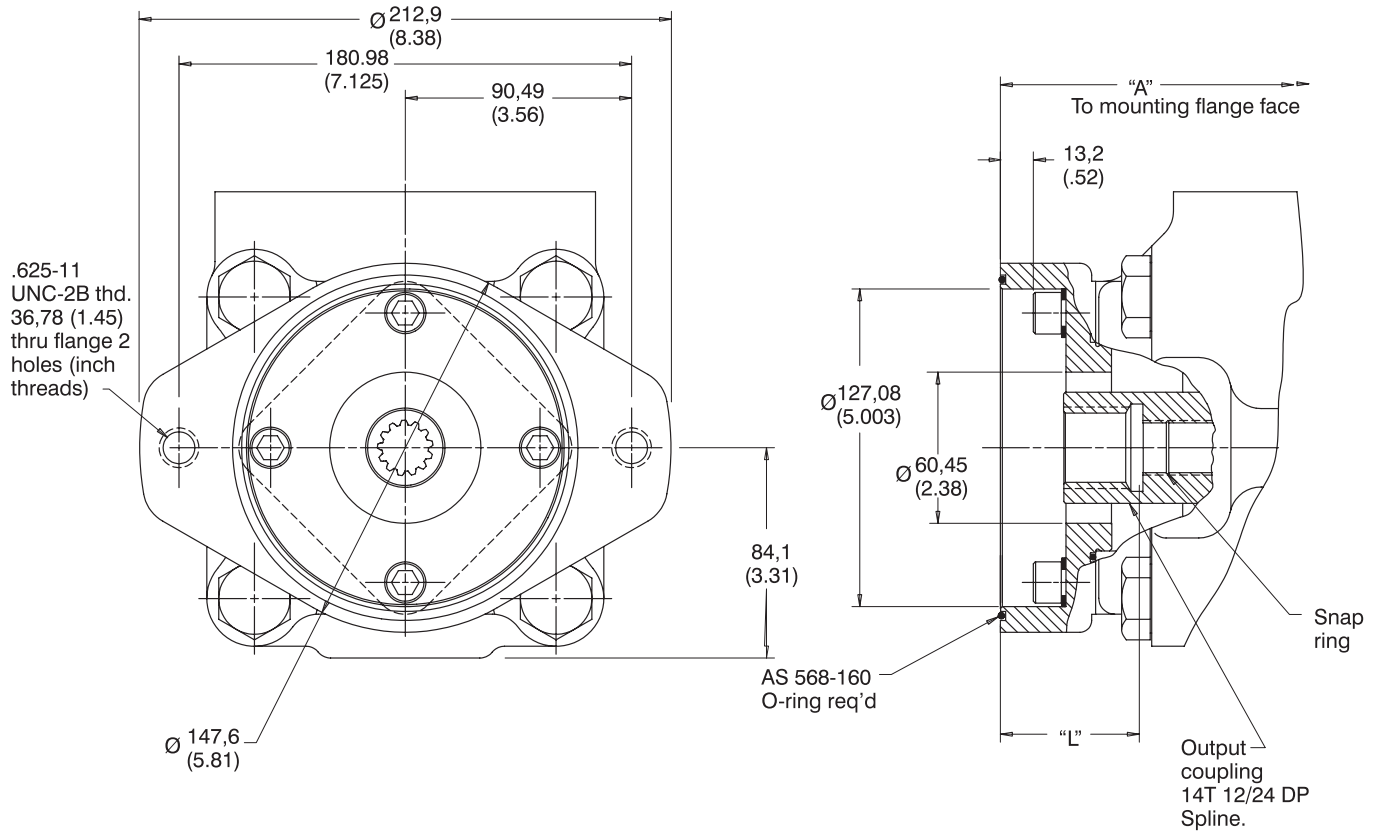

Dimension "A"			Dimension "L"*
Pump Model	**VTCS Models	**VTCM Models	
35VTC	275,8 (10,86)	275,8 (10,86)	56,6/54,2 (2,23/2,13) 61,2 (2.41) Maximum
45VTC	308,4 (12,14)	338,6 (13,33)	56,6/54,2 (2,23/2,13) 61,5 (2.42) Maximum

* Caution: Dimension "L" is important and must be observed.

NOTE: This unit **accepts** a hydraulic pump which conforms to flange and shaft codes specified in ISO 3019/1 (SAE J744 Jul88),

Flange Code	Shaft Code	SAE J744C (Ref)
127-2	32-4	C

**VTC

The following Vickers shaft selection will comply with the above:

Rear Pump Model	Shaft
35V Vane pump	11
3520/3525V Double pumps	11
45V Vane pump	11

Optional Shafts

Straight Key Shafts

Thru-drive shafts, see pages 34.

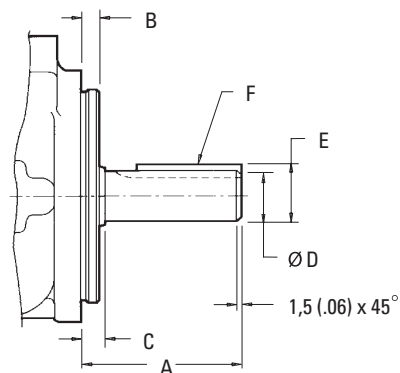

Pump	Shaft Code	A	B	C	øD	E	F key width x length
20V	1	59 (2.32)	9,53 (.375)	12,1 (.476)	22,23 (.875) 22,20 (.874)	24,5 (.966) 24,4 (.961)	4,75 (.817) x 32 (1.25)
25V 2520V	1	59 (2.32)	9,53 (.375)	11,1 (.435)	22,23 (.875) 22,20 (.874)	24,5 (.966) 24,4 (.961)	4,75 (.817) x 32 (1.25)
25V 252*V	86	78 (3.06)	9,53 (.375)	11,1 (.435)	25,37 (.999) 25,35 (.998)	28,3 (1.11) 28,1 (1.10)	6,36 (.250) x 50,8 (2.00)
25VM 252*VM 25VT*M	292N	52,3 (2.06)	9,25 (.364)	10,4 (.41)	25,02 (.985) 25,00 (.984)	28,02 (1.10) 27,81 (1.09)	8,00 (.314) x 28 (1.10)
25VT*S 25VS	202	71,4 (2.81)	9,53 (.375)	7,9 (.310) ▲	22,23 (.875) 22,20 (.874)	25,15 (.990) 24,90 (.980)	6,36 (.250) x 50,8 (2.00)
252*VS	203	77,7 (3.06)	9,53 (.375)	7,9 (.310) ▲	25,40 (1.00) 25,35 (.998)	28,20 (1.11) 27,94 (1.10)	6,36 (.250) x 50,8 (2.00)
35V 352*V	1	73,2 (2.88)	9,53 (.375)	11,1 (.435)	31,75 (1.25) 31,70 (1.24)	35,36 (1.39) 34,10 (1.38)	7,94 (.313) x 38,1 (1.50)
	86	86 (3.88)	9,53 (.375)	11,1 (.435)	34,90 (1.374) 34,87 (1.373)	38,6 (1.52) 38,3 (1.51)	7,92 (.312) x 54 (2.13)
35VM 352*VM 35VT*M	292N	68,4 (2.70)	9,12 (.359)	10,4 (.41)	37,01 (1.457) 36,75 (1.447)	35,00 (1.378) 34,80 (1.370)	10 (.394) x 45 (1.77)
35VS 352*VS	202	84,1 (3.31)	12,7 (.50)	10,4 (.41)	31,75 (1.25) 31,70 (1.24)	35,36 (1.39) 34,10 (1.38)	7,94 (.313) x 45 (1.77)
35VT*S 35VS 352*VS	203	84,1 (3.31)	12,7 (.50)	7,9 (.310) ▲	34,90 (1.374) 34,87 (1.373)	38,56 (1.518) 38,30 (1.508)	7,92 (.312) x 54 (2.125)
45V 45**V	1	62 (2.44)	12,7 (.500)	14,22 (.560)	31,75 (1.25) 31,70 (1.24)	35,36 (1.39) 34,10 (1.38)	7,92 (.312) x 28,5 (1.12)
	86	87,4 (3.44)	12,7 (.500)	14,22 (.560)	38,07 (1.499) 38,05 (1.498)	42,4 (1.67) 42,1 (1.66)	9,53 (.375) x 50,8 (2.00)
45VS 45**VS	202	84,1 (3.31)	12,7 (.500)	14,22 (.560)	31,75 (1.25) 31,70 (1.24)	35,36 (1.39) 34,10 (1.38)	7,94 (.313) x 63 (2.48)
45VM 452*VM 45VT*M	292N	92 (3.62)	9,12 (.359)	10,0 (.394)	40,01 (1.575) 39,99 (1.574)	43,0 (1.693) 42,8 (1.685)	12 (.472) x 63 (2.48)
45VT*S 45VS 45**VS	203	87,4 (3.44)	9,14 (.360)	7,9 (.310) ▲	38,07 (1.499) 38,05 (1.498)	42,4 (1.67) 42,1 (1.66)	9,53 (.375) x 57,1 (2.25)

▲ Shaft shoulder inside recess in pilot.

Optional Shafts

Splined Shafts

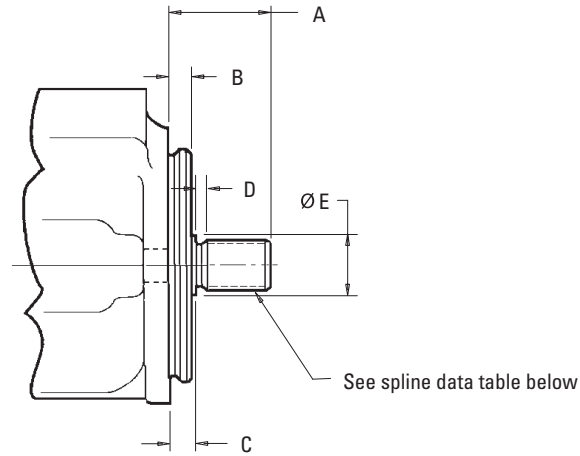

Pump	Shaft Code	A	B	C	D	øE	Spline Data (see below)
20V	151	41,1 (1.62)	9,53 (.375)	11,1 (.437)	3,9 (.156)	27,8 (1.09)	A
25V 2520V	11	44,5 (1.75)	9,53 (.375)	11,1 (.437)	3,9 (.156)	27,8 (1.09)	A
2525V	174	59,9 (2.36)	9,53 (.375)	17,3 (.68)	3,0 (.12)	29,2 (1.15)	B
25VT*S 25VS 252*VS	297	41,1 (1.62)	9,14 (.36)	7,9 (.31)	4,1 (.16)	27,8 (1.09)	C
35V 352*V	11	58,7 (2.31)	9,53 (.375)	11,1 (.437)	6,35 (.25)	35,1 (1.38)	D
35VT*S 35VS 352*VS	297	55,5 (2.19)	9,14 (.360)	7,9 (.310)	5,5 (.21)	35,1 (1.38)	E
45V 45**V	11	61,9 (2.44)	12,7 (.500)	14,3 (.565)	9,7 (.38)	39,6 (1.56)	D
45VT*S 45VS 45**VS	297	55,5 (2.19)	9,14 (.360)	7,9 (.310)	9,7 (.38)	39,6 (1.56)	E

Spline Data Table

(Involute splines from above chart)

Spline Data Reference	Number of Teeth	Pitch	Major Diameter	Form Diameter	Minor Diameter	Minor Diameter
A	13	16/32	22,17 (.873) 22,15 (.872)	19,03 (.749)	18,63 (.734) 18,35 (.723)	Major dia. fit
B	14	12/24	31,22 (1.23) 31,11 (1.22)	27,48 (1.08)	27,0 (1.063) 26,7 (1.05)	Side fit
C	13	16/32	22,2 (.875) 21,7 (.853)	19,03 (.749)	18,4 (.725)	Side fit
D	14	12/24	31,7 (1.25) 31,67 (1.247)	27,2 (1.07)	26,99 (1.06) 26,64 (1.05)	Major dia. fit
E	14	12/24	31,6 (1.25) 31,1 (1.22)	27,48 (1.08)	26,7 (1.05)	Side fit

Optional Shafts

Optional ISO 3019/2 Metric Pilot Flange Mounting Options for "VM" & "VT*M" Pumps

25 and 35 Size Pumps

Model	A	ØB	ØC	Pilot diameter
25VM Single Pumps				
25VT*M Thru-drive Pumps	14,27	140	175	100,0 (3.937)
25**VM Double Pumps	(.562)	(5.51)	(6.87)	99,95 (3.935)
35VM Single Pumps				
35VT*M Thru-drive Pumps	18,34	180	212	125,02 (4.922)
35**VM Double Pumps	(.722)	(7.09)	(8.33)	124.97 (4.920)

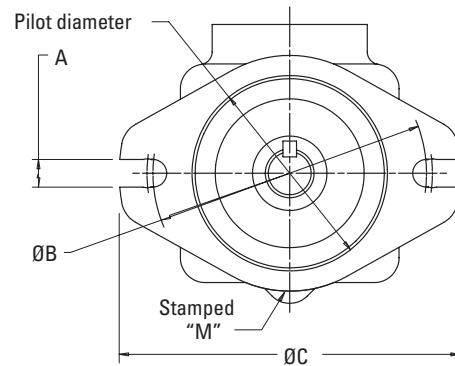

45 Size Pumps

- 45VM Single Pumps
- 45VT*M Thru-drive Pumps
- 45**VM Double Pumps

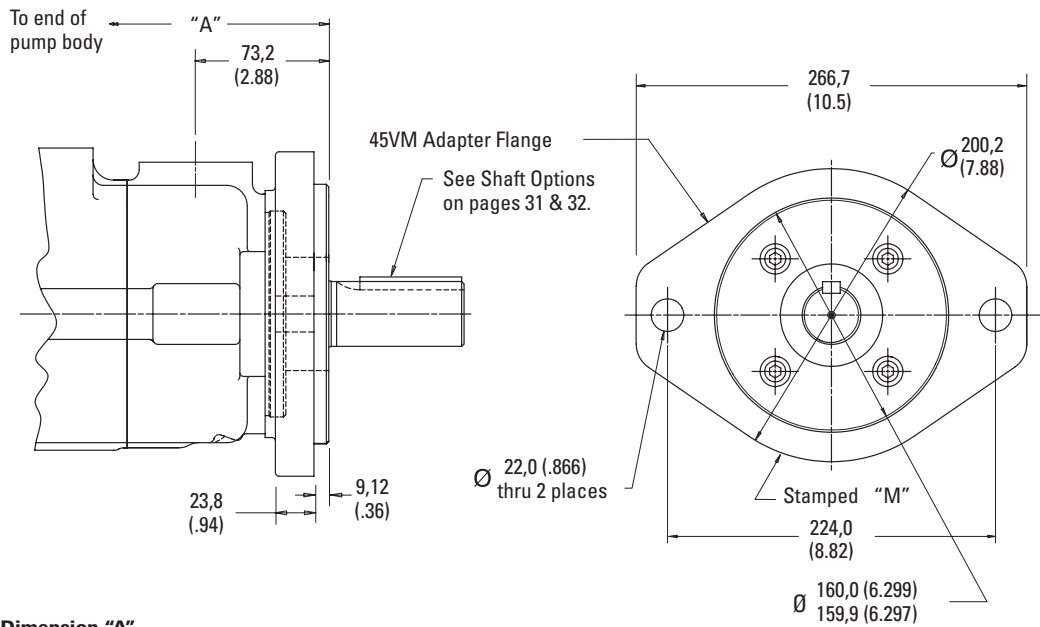

45VT** Thru-drive Pumps		Dimension "A"
Rear Mounting Type	45VT*S Pumps	45VT*M Pumps
A	291,6 (11.48)	321,8 (12.67)
B	300,7 (11.84)	331,0 (13.03)
BP	317,0 (12.48)	347,2 (13.67)
C	308,4 (12.14)	338,6 (13.33)

Torque Loading for Direct Drives

Single pumps (not thru-drive models) All listed shafts are satisfactory up to maximum pressures in "Pressure and speed limits" in operating data for each series.

Double pumps

Where both cartridges are to be on-load together, check that the sum of their separate torques, taken from the graph below (right), does not exceed the torque limit in shaft torque Table 1.

Thru-drive pumps **VT* models Where both the thru-drive pump and its rear-mounted pump are to be on-load together, check that the sum of the torques generated will never exceed the torque limit in shaft torque Table 2. Also check that the torque required on the rear-mounted pump never exceeds the thru-drive torque limit in shaft torque Table 2.

Table 1
Single & Double Pumps Shaft Torque Ratings

Pump Model	Shaft No.	Maximum input torque Nm (lb-in)
25V or 25**V	1	250 (2200)
	11	250 (2200)
	86	400 (3560)
	174	550 (4900)
35V or 35**V	292N	316 (2800)
	1	400 (3560)
	11	580 (5100)
	86	600 (5300)
45V or 45**V	292N	400 (3560)
	1	400 (5300)
	11	820 (7200)
	86	820 (7200)
	292N	820 (7200)

Example:

A 3525V38A17 pump operating at 172 bar (2500 psi) front section and 138 bar (2000 psi) rear section will require over 450 Nm (4000 lb-in) input torque. Therefore, all listed shafts are acceptable except No.1.

Table 2 Thru-Drive Pumps Shaft Torque Ratings

Pump Model	Shaft No.	Max. Input Torque Nm (lb-in)*	Thru-drive connection	Max. Thru-drive Torque Nm (lb-in)
	202	250 (2200)	A	131 (1160)
			B	250 (2200)
25VT*S 25VS	203	400 (3560)	A	131 (1160)
			B	316 (2800)
242*VS	297	316 (2800)	A	131 (1160)
			B	316 (2800)
	292N	316 (2800)	A	131 (1160)
			B	316 (2800)
292N	400 (3560)	A	131 (1160)	
		B	316 (2800)	
		C	400 (3560)	
35VT*S 35VS 352*VS	203	600 (5300)	A	131 (1160)
			B	316 (2800)
			C	437 (3870)
	297	790 (7000)	A	131 (1160)
			B	316 (2800)
			C	437 (3870)
292N	904 (8000)		A	131 (1160)
			B	384 (3400)
			C	702 (6210)
45VT*S 45VS 45**VS	203	810(7200)	A	131 (1160)
			B	384 (3400)
			C	702 (6210)
297	1020 (9000)		A	131 (1160)
			B	384 (3400)
			C	702 (6210)

* Combined torque of Vickers "VT" pump and thru-drive pump.

Input Torque Requirement

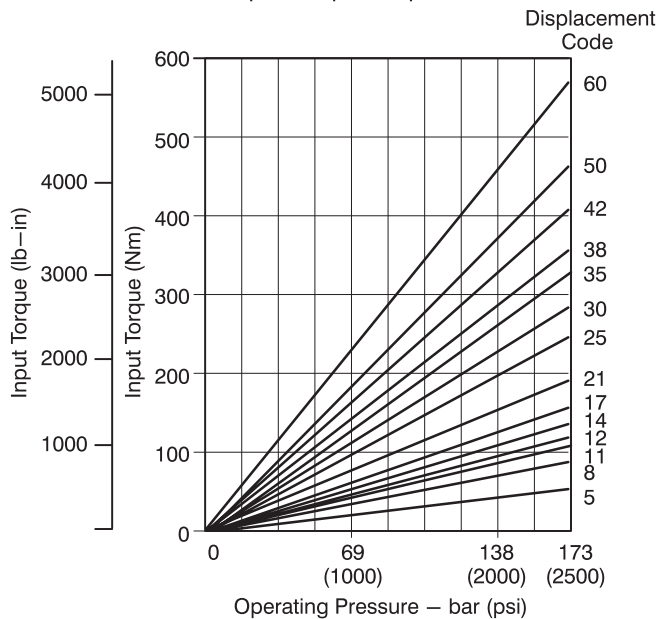

Drives

Recommended Drives

Vickers units are designed for use on direct coaxial drives using spline connections and/or flexible couplings. If drives imposing radial and/or axial loads, or key drives are being considered, consult your Vickers representative for additional information.

Drive Alignment

Concentricity and angular alignment of shafts are important to pump life. Misalignment can induce heavy loads on bearings, causing premature failure. Flexible coupling halves must be aligned according to the coupling manufacturer's recommendations.

Universal Joints

When using double universal joint couplings, the shafts must be parallel and the yokes must be in line. The offset should be kept as low as possible. Maximum allowable offset will, of course, vary with application conditions. The pump shaft to universal joint diametral fit should be close (major diameter fit) with no appreciable looseness.

Mounting Pad Accessory Drives

A splined shaft is recommended on applications where the pump shaft is coupled directly into a transmission or gear box. Spline drives should be lubricated. The possibility of interference between the shaft and transmission splines, due to tolerance stack-up, can exist. To reduce this possibility, side tooth spline fits should be used. A side tooth fit and short length of engagement permits more flexibility and less tendency for side loading than does a major diameter fit spline or long spline engagement.

Mounting Dimensions

Requirements

Dimensional control requirements of the customer's mounting pad to which the pump or motor is affixed are as follows.

Pilot Diameter

Concentricity of the customer's female pilot diameter relative to the effective axis of the female drive must be within .10 mm (.004") total indicator reading. The clearance between the male and female pilot diameters must be +.0127 to .0508 mm (+.0005 to +.0020 inch).

Mounting Face

The customer's mounting face to which the pump or motor is affixed must be square to the axis of the female drive within .04 mm per 25 mm (.0015 inch per inch).

Shafts

Dimensions of keyed shaft receivers must be between +.002554 and +.0254 mm (+.0001 and +.0010) of the maximum shaft diameter shown on the respective Vickers installation drawing.

Foot Mounting Bracket Option

(Not suitable for thru-drive pumps)

Salts for mounting pump are supplied with bracket.

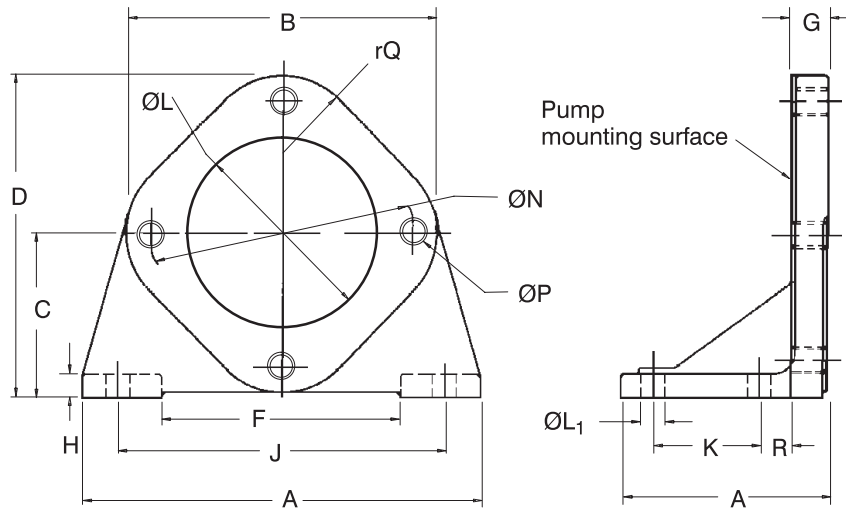

Part No.	A	B	C	D	E	F	G	H	J
422583	171 (6.75)	178 (7.00)	92 (3.625)	181 (7.125)	93 (3.656)	98 (3.858)	17,4 (.687)	13 (.50)	146 (5.750)
422584	265 (10.43)	212 (8.37)	109,5 (4.312)	216 (8.50)	129 (5.06)	164 (6.46)	19 (.750)	16 (.62)	235 (9.250)

Part No.	K	øL	øL1	øN	øP	rQ	R
422583	50,8 (2.00)	101,6 (4.00)	11,1 (.593)	146 (5.750)	1/2"-13 UNC	51 (2.00)	13
422584	76,2 (3.00)	127 (5.00)	17,5 (.68)	180,7 (7.125)	3/8"-11 UNC	64 (2.52)	19

422583 for use with frame sizes 20, 25 and .2520 pumps. Weighs 2,7 kg (6 lbs.)
 422584 for use with frame sizes 35, 45, 35** and 45** pumps. Weighs 5,9 kg (13 lbs.)

Application Data

Moment of Inertia

Model	Nm/sec ²	Moment lb-in-sec ²
25V	0,000757	(.00670)
35V	0,001395	(.01235)
45V	0,003073	(.02720)
2520V	0,001309	(.01159)
2525V	0,001469	(.01300)
3520V	0,001629	(.01495)
3525V	0,002042	(.01807)
4520V	0,003186	(.02820)
4525V	0,003732	(.03303)
4535V	0,004554	(.04031)

Vane Pump Approximate Weights

Frame size	kg (lbs.)	
20V	12.0	(26)
25V	14.8	(33)
25V(T)	19.4	(43)
35V	22.7	(50)
35V(T)	28.7	(63)
45V	34.0	(75)
45V(T)	38.1	(84)
2520V	20.5	(45)
2525V	23,1	(51)
3520V	34.0	(75)
3525V	34.5	(76)
4520V	43.0	(95)
4525V	46.0	(101)
4535V	53.5	(118)

Mounting Options

Mounting attitude of all pumps is unrestricted except for any limitations in respect to rear-end pumps to be titled to **VT pumps. Such limitations will be found in the technical literature for those specific pumps.

Ordering Procedure

State full model designation(s) when ordering pumps. Port flange kits are available from Vickers and must be ordered as separate items.

Specify "BP" adapter when coupling PVE12119/21 as second pump on thru-drives.

Existing "B" thru-drives can be converted to "BP" using the following kits:

25VT: 941295 Adapter kit
452865 Coupling

35VT/45VT: 941295 Adapter kit only

Note: Adaptor kit and couplings are included with unit when ordered with "BP" designation in model code.

Service Information

Refer to specific Vickers part drawing or overhaul manual (below) for service information or consult your Vickers representative.

Service Literature:

20V	1-3195-5
25V	1-3196-5
35V	1-3197-5
45V	1-3199-5
2520V	1-3200-5
2525V	1-3212-5
3520V	1-3202-5
3525V	1-3203-5
4520V	1-3204-5
4525V	1-3208-5
4535V	1-3209-5
25VT	1-3154-5
35VT	1-3149-5
45VT	1-3151-5

Overhaul Manuals:

25V	1-3157-5
25VT	1-3157-5
35V	1-3157-5
35VT	1-3157-5
45V	1-3157-5
45VT	1-3157-5
2520V	1-3155-5
3520V	1-3155-5
3525V	1-3155-5
4520V	1-3155-5
4525V	1-3155-5
4535V	1-3155-5

Eaton
Hydraulics Group USA
14615 Lone Oak Road
Eden Prairie, MN 55344
USA
Tel: 952-937-9800
Fax: 952-294-7722
www.eaton.com/hydraulics

Eaton
Hydraulics Group Europe
Route de la Longeraie 7
1110 Morges
Switzerland
Tel: +41 (0) 21 811 4600
Fax: +41 (0) 21 811 4601

Eaton
Hydraulics Group Asia Pacific
Eaton Building
4th Floor, No. 3 Lane
280 Linhong Rd. Changning District
Shanghai 200335
China
Tel: (+86 21) 5200 0099
Fax: (+86 21) 5200 0400