



HYDRAULIC COMPONENTS
HYDROSTATIC TRANSMISSIONS
GEARBOXES - ACCESSORIES

Certified Company ISO 9001:2015 - 14001:2015



ISO 9001:2015 Certificate N° 12-Q-000545-TIC
ISO 14001:2015 Certificate N° 12-E-000545-TIC

Via M. L. King, 6 - 41122 MODENA (ITALY)

Tel: +39 059 415 711

Fax: +39 059 415 730

INTERNET: <http://www.hansatmp.it>

E-MAIL: hansatmp@hansatmp.it

HT 16 / M / 2010 / 1218 / E

THE PRODUCTION LINE OF HANSA-TMP

Variable Displacement Closed Loop System Axial Piston Pump

TPV 4300

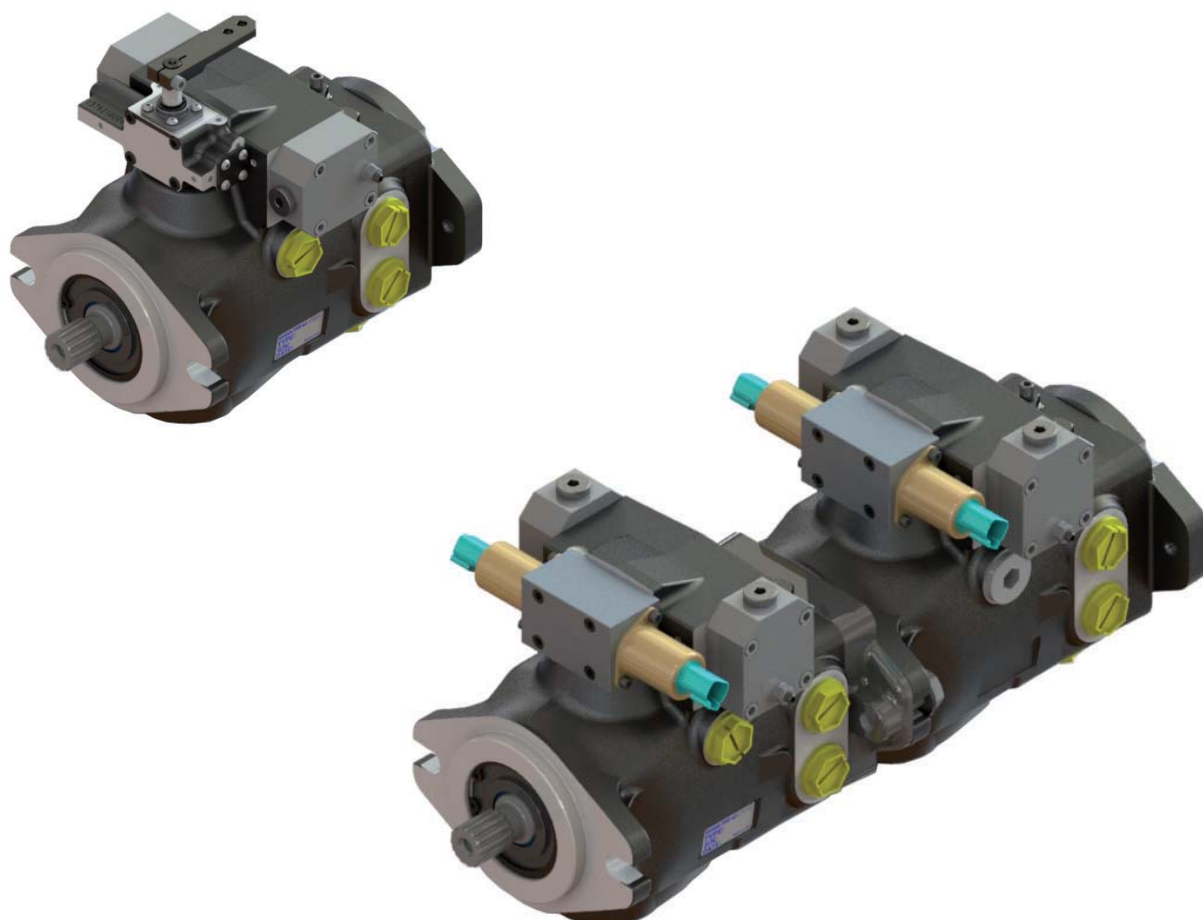

INDEX

General information.....	5
Technical specifications.....	6
System design parameters.....	7
Performance diagram.....	8
Installation instructions.....	9 - 10
Hydraulic fluid.....	11
Hydraulic fluid filtration.....	12
TPV 4300	
Order code.....	14 - 15
General dimensions/pump ports.....	16
Shaft option and mounting flanges.....	17
SHI Hydraulic servo control.....	18 - 19
SEI 1.3 - 2.3 Electro-proportional servo control.....	20 - 22
SEI 1.3D - 2.3D Electro-proportional servo control.....	23 - 25
SHIX Hydraulic servo control with feed back.....	26 - 27
SMIX Manual lever control with feed back.....	28 - 29
SEIX 1.2 - 2.2 Electro-proportional servo control with feed back.....	30 - 32
SEIX 1.2D - 2.2D Electro-proportional servo control with feed back.....	33 - 35
Rear pump mounting flanges.....	36 - 37
Optional SB Screw by-pass	38
Optional FR Pre-arrangement for external filter-connection.....	39
Optional CO (--) Pressure cut-off valve (pressure setting).....	40 - 41
Optional MOB Man on board with SHI Hydraulic servo control.....	42 - 43
Optional MOB Man on board with SEI Electro-proportional servo control...	44

INDEX
(continued)**TPVT 4300**

Order code.....	46 - 48
General dimensions/Tandem pump ports.....	49
SHI Hydraulic servo control.....	50 - 51
SEI 1.3 - 2.3 Electro-proportional servo control.....	52 - 54
SEI 1.3D - 2.3D Electro-proportional servo control.....	55 - 57
SHIX Hydraulic servo control with feed back.....	58 - 59
SMIX Manual lever control with feed back.....	60 - 61
SEIX 1.2 - 2.2 Electro-proportional servo control with feed back.....	62 - 64
SEIX 1.2D - 2.2D Electro-proportional servo control with feed back.....	65 - 67
Rear pump mounting flanges.....	68 - 69
Optional SB Screw by-pass	70
Optional FR Pre-arrangement for external filter-connection.....	71
Optional MOB Man on board with SHI Hydraulic servo control.....	72 - 73
Optional MOB Man on board with SEI Electro-proportional servo control...	74 - 75
Trouble shooting.....	76
Accessories.....	77

GENERAL INFORMATION

- The new TPV-TPVT 4300 are variable displacement axial piston pumps with swash-plate system, for closed loop hydrostatic transmissions, that offer the best power to weight ratio because of new innovative design and production technologies.
- The flow rate is proportional to the rotation speed and is continuously variable according to the angle of the swash-plate from "0" to maximum displacement.
- The TPV-TPVT 4300 is equipped with a boost pump, "gerotor" type of new design and high efficiency to keep the circuit pressurised, to compensate the oil leakages of the hydrostatic transmission, to avoid cavitation of the piston pump and to supply low pressure oil flow to the remote controls of the pumps and of the hydraulic transmission (max 3 MPa).
- Different types of hydraulic or electro-proportional controls are available for remote regulation of the pump displacement by means of hydraulic or electric joysticks.
The mounting flange is according to SAE-B 2 bolt, the through-drive is according SAE-A 2 bolt.
Different other optionals are available for the TPV-TPVT 4300.
- The piston pumps are to be considered as individual components for the purposes of Directive 98/37/EC, therefore have been built to be integrated into a circuit or to be assembled with other components to form a machine or system. They can be operated only after they have been installed in the machine/system which they are intended for.
- The TPV-TPVT 4300 pumps must be used to create, manage and regulate oil flow in a closed loop system. Any other use should be considered improper.
- The pumps are built according to the technology normally used for this type of product. There is the risk of injury or damage to personnel during their installation and use if you do not respect the normal safety instructions or if used by untrained personnel.

TECHNICAL SPECIFICATIONS

The housing and the distributor of the pumps TPV-TPVT 4300 are made in cast iron.

The flow rate is proportional to the rotation speed and the displacement is continuously variable. It increases as the swash-plate angle moves from "0" to maximum position.

If the swash-plate is positioned out of the neutral position, the flow respectively follows one of the two directions.

Typical applications

- construction equipments
- green mowers
- zero turn machines
- agricultural machines
- utility vehicles
- forest vehicles
- logistic machines

Key features

- compact design
- integrated optionals
- high power to weight ratio
- low noise integrated boost pump

PUMP MODEL		TPV 32	TPV 38	TPV 45	TPV 50
Theoretical max. displacement	cm ³ /n	32	38	45	50
Flow rating ⁽¹⁾	l/min	115	137	162	180
Power rating ⁽¹⁾	kW	48	57	67,5	75
Boost pump displacement	cm ³ /n	14			
Rated pressure	MPa	28			
Max. pressure	MPa	32			
Boost pressure ⁽²⁾	MPa	1,5-2,6			
Absolute suction pressure ⁽³⁾	MPa	> = 0,08			
Max. case pressure	MPa	0,15			
Minimum speed	n/min	700			
Rated speed	n/min	3.600			
Max. speed	n/min	3.900			
Max. fluid temperature	°C	80			
Fluid viscosity	cSt	15-35			
Fluid contamination		19/17/14 ISO 4406 (NAS 8)			
Mass (single pump with hydr-servo)	kg	24			
Mass (tandem pump with hydr-servo)	kg	49,5			

(1) $[V_{max} - \eta_{max}]$

(2) 1.500 n/min

(3) $v \leq 30 \text{mm}^2/\text{s}$

SYSTEM DESIGN PARAMETERS

HYDRAULIC MEASURE	USEFUL FORMULAS	CONVERSION FACTORS
Flow rate: Q = (l/min)	$Q = V [cm^3/n] \times \eta_v \times n \times 10^{-3}$	1 l/min = 0,2641 US Gal/min
Pressure: P = (MPa)		1 MPa = 145 PSI
Displacement: V = (cm ³ /n)		
Torque: M = (Nm)	$M = \frac{\Delta p [MPa] \times V [cm^3/n]}{6.283 \times \eta_m}$	1 Nm = 8,851 in lbs
Power: P = (kW)	$P = \frac{\Delta p [MPa] \times V [cm^3/n] \times n}{60 \times 1000 \times \eta_t}$	1 KW = 1,36 HP
Shaft speed: n = n/min		
Hydraulic efficiency: = η_v		
Mechanical efficiency: = η_m		
Overall efficiency: = η_t		
		1 mm = 0,0394 in
		1 kg = 2,205 lbs
		1 N = 0,2248 lbs

PERFORMANCE DIAGRAM

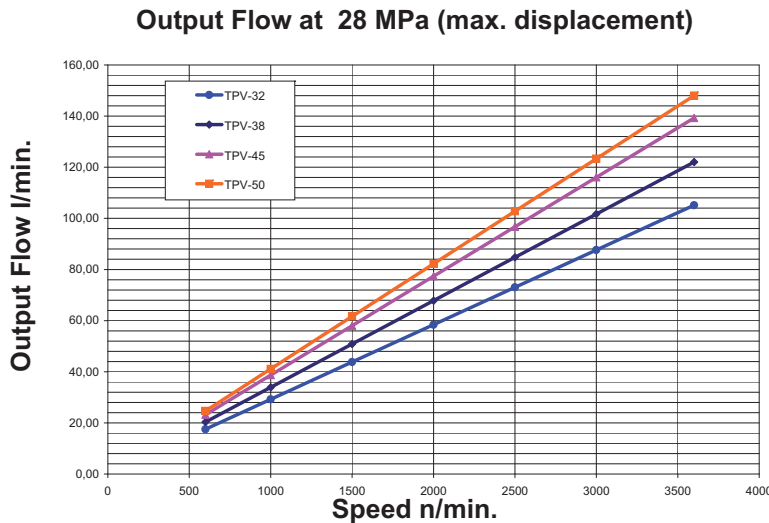
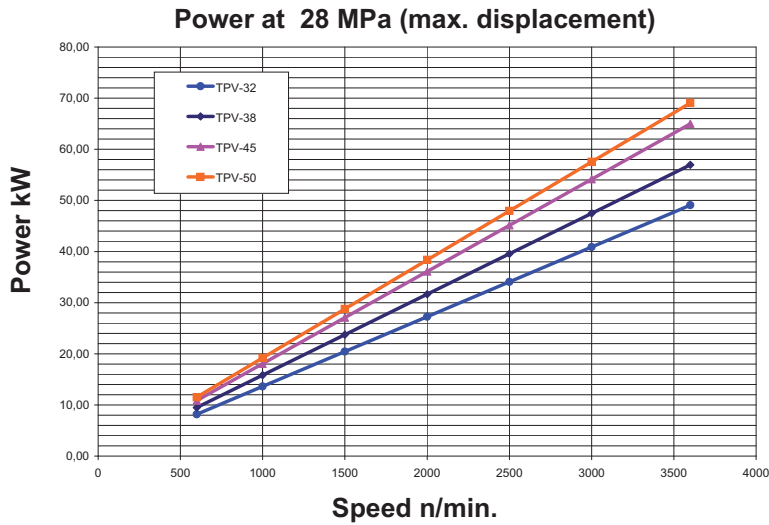

Performance diagrams

- The diagrams show the data of maximum speed and maximum continuous pressure.
- Data may vary depending on pump displacement.

Pressure

- Continuous pressure: is the average pressure for continuous work, which must not be exceeded, to ensure a correct and long lasting service of the pump.
- Maximum pressure: is the maximum allowable pressure for short periods and must never be exceeded.

Speed

- Continuous work speed: is the maximum

recommended speed for continuous operation of the pump under full load.

- Maximum speed: is the maximum permissible speed for the pump for short periods and not fully loaded. The use of the pump with this speed can reduce the life and cause a loss of power or of the hydrostatic braking capacity.

Caution

Any damage caused to the pump can reduce or eliminate the hydrostatic braking capacity. It is therefore necessary to provide an auxiliary braking system capable of stopping and supporting the weight of the complete machine, in the event of loss of hydrostatic power.

INSTALLATION INSTRUCTIONS

Standards for the installation, start up and maintenance

- When mounting the pump above the minimum level of the tank, distance of the highest point of the pump over the oil level **MUST NOT** exceed 250 mm.
- To reduce the noise level typical of all piston pumps we recommend:
 - use hoses instead of pipes
 - limit to a minimum the length of eventual pipes
 - fix rigid pipe sections with special supports equipped with rubber vibration dampening devices
 - use pipes and hoses with a diameter according to the speed values below:

Suction line = $0,6 \div 1,2$ m / s

Drain = $1,5 \div 3,6$ m / s

Pressurized lines = max 6 m / s

- To calculate the speed of the oil in the lines refer to the formula below:

$$V = Q * 21,22 / D$$

V = speed (m/s)

Q = flow rate (l/min)

D = internal pipe/hose diameter (mm)

- In any case **NEVER** use pipes/hoses or fittings with diameter smaller than that of the corresponding ports on the pump. This indication is **ABSOLUTELY OBLIGATORY** for the drain line to avoid to pressurize the pump housing and extrude the lip seal of the pump shaft.
- During mounting cure the alignment of the pump, concentric with the drive shaft sleeve to prevent overloading of the bearing. See page 10.
- For the hydraulic system, we recommend using pipes/hoses washed internally with hydraulic oil or, even better, with solvent.
- Special care must be taken when cleaning the inside of the tank (painting is recommended after sand blasting).
- To improve the functionality of the boost pump, it is recommended to place it below minimum tank level.
- The pumps can be installed in any direction and position.
For further information contact our Technical Department.

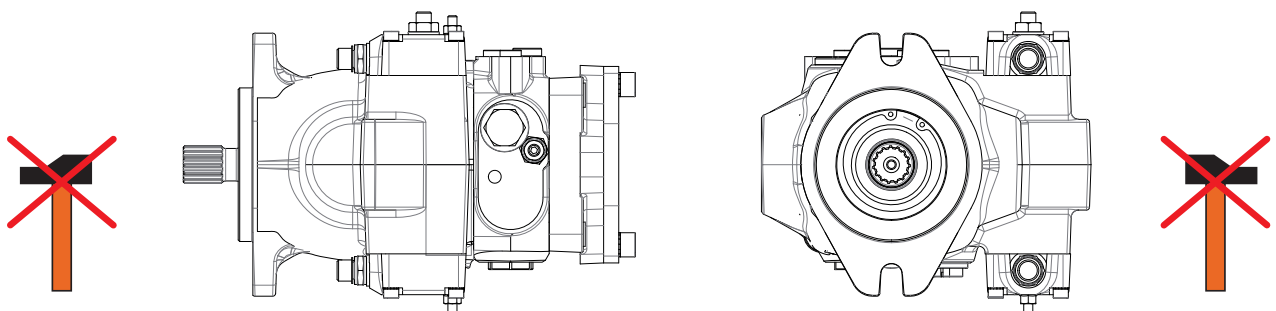

(continued)

INSTALLATION INSTRUCTIONS**Shaft Coupling**

To connect the pump shaft to the engine flywheel or electric motor shaft use a flexible

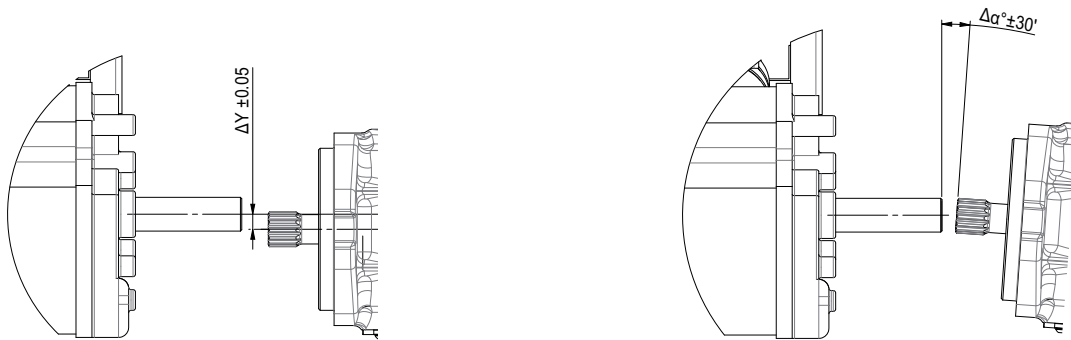

coupling. The alignment must be within the tolerances indicated in the figures above. For an optimal function of the pump the shaft should not be subjected to radial or axial loads. During the installation or removal, do not force the coupling of the pump shaft, but always use the threaded hole on the shaft.

Start up

- Before starting fill the tank and the other components with new filtered oil. You should run a flushing of the complete hydraulic system (see Use and Maintenance Manual). Check that the low pressure value is correct (refer to the Use and Maintenance Manual).
- Restore the oil level in the tank.

Maintenance

- The first oil change should be made after 500 hours of operation. Later change the oil every 2000 hours.
- The first replacement of the filter cartridge has to be made after 50 hours for a preliminary circuit cleaning. Then after further 500 hours.
- These frequencies have to be reduced in the case where the indicator shows the clogging of the filter cartridge and in case of operation in environments with a high level

of contamination.

CAUTION

- Always work with the utmost attention to the moving parts; do not use loose or fluttering clothing.
- Do not approach rotating wheels, tracks, chains or shafts if not properly protected, or when they may start moving without notice.
- Do not loosen or disconnect fittings and pipes/hoses while the engine is running.
- Avoid oil leaks in order to prevent environmental pollution.

Load capacity of rear shaft (through drive shaft)

- The rear shaft is not able to carry radial loads.

HYDRAULIC FLUID

Viscosity

The maximum duration and the maximum efficiency are related to the optimum range of viscosity.
Optimal operating viscosity 15 ÷ 40 cSt referred to the temperature of the closed circuit.

and with the maximum temperature of the drain oil at 90 °C.
Max. viscosity = 1000 cSt for a few seconds, only during cold starting.

Working conditions

For working conditions apply the following limits:
Minimum viscosity = 10 cSt for short moments

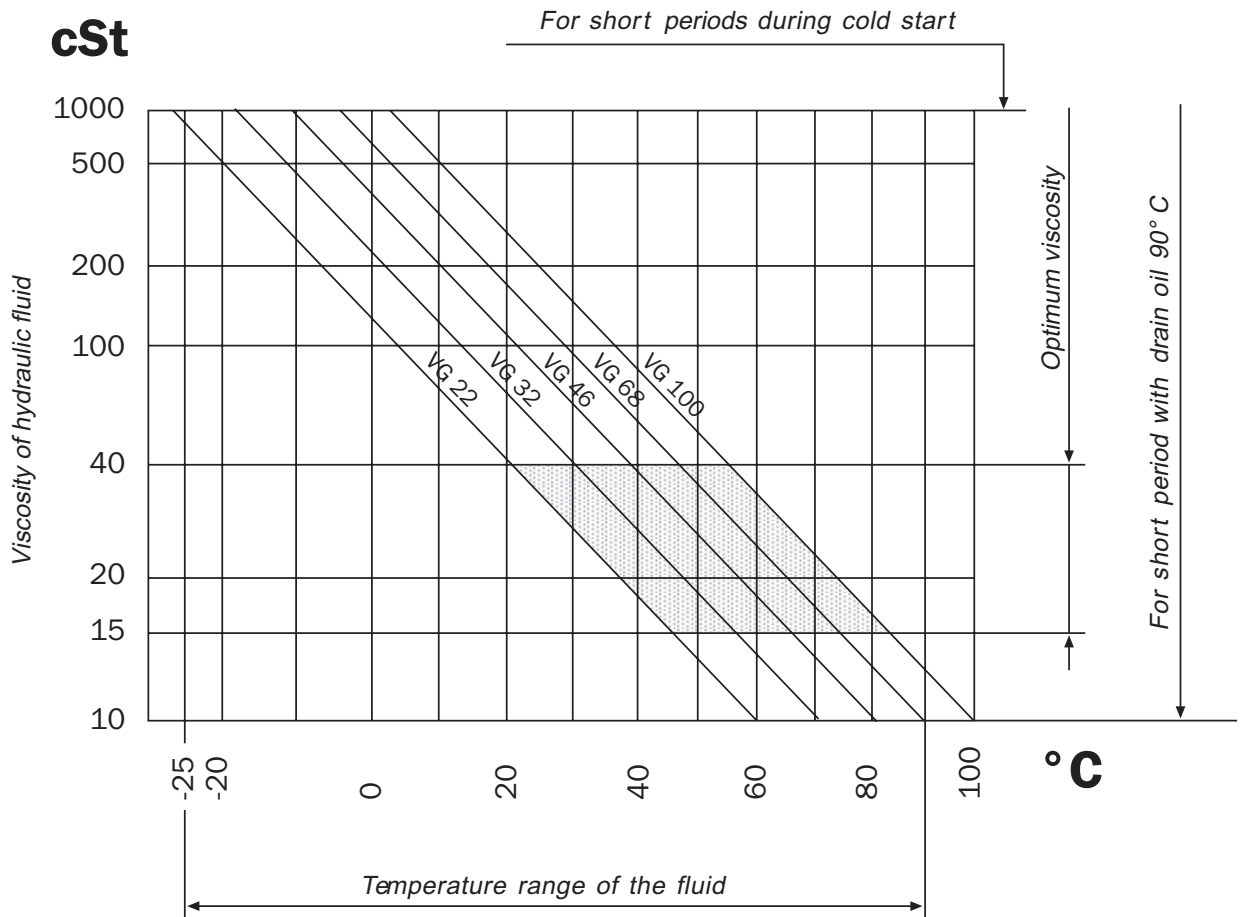

HANSA - TMP cannot be held responsible concerning non compliance of these instructions and observance of safety regulations, although not covered by this document.

HYDRAULIC FLUID FILTRATION

The contaminating particles suspended in the hydraulic fluid cause the wear of the hydraulic mechanisms moving parts.

On hydraulic pumps these parts operate with very small dimensional tolerances.

In order to prolong the parts life, it is recommended to use a filter that maintains the hydraulic fluid contamination class at max.

8 according to NAS 1638

5 according to SAE, ASTM, AIA

19/17/14 according to ISO 4406

According to the type of application decided for the pump, it is necessary to use filtration elements with a filtration ratio of:

$$\beta_{(x)} 20 \div 30 \geq 75$$

making sure that this ratio does not worsen together with the increasing of the filter cartridge differential pressure. While the pump is working, its temperature increases (over 80° to 110°C) with negative effects on pump performances; as a consequence, it is important to observe a max. contamination level of:

7 according to NAS 1638

4 according to SAE, ASTM, AIA

18/16/13 according to ISO 4406

If these values cannot be secured, the component life will consequently be reduced and it is recommended to contact our Tech. Dept.

Suction filters

The suction filters must have a clogging indicator and bypass. The max. pressure drop of the filtration element must not exceed 0,04 absolute MPa (0,08 absolute MPa with cold start).

Filter assembling

The suction filter is mounted in the suction line. Check that the pressure before the boost pump is 0,08 absolute MPa, measured on the

pump suction port (0,05 MPa for cold starting).

TPV 4300

VARIABLE DISPLACEMENT AXIAL PISTON PUMP



ORDER CODE _____

4300 0	TPV 1	32 2	CR 3	SS5 4	F2.2 5	SHI 6	OA 7	15 8	14 9	SA 10	000 11	SB 12
-----------	----------	---------	---------	----------	-----------	----------	---------	---------	---------	----------	-----------	----------

Pag.

4300	0 - Pump series = TPV pump 4300	
TPV	1 - Pump model = Closed loop circuit pump	
	2 - Pump displacement pump 32 = 32 cm ³ /n 38 = 38 cm ³ /n 45 = 45 cm ³ /n 50 = 50 cm ³ /n	
CR	3 - Pump rotation = Clockwise Rotation (right)	
CC	= Counter-clockwise rotation (left)	
SS3	4 - Shaft (mounting side) = Splined shaft Z13 - 16/32 D.P	17
SS5	= Splined shaft Z15 - 16/32 D.P	17
F2.2	5 - Mounting side flange = SAE-B 2 holes - pilot diam. 101,6 mm.	17
SHI	6 - Control devices = Hydraulic servo control	18
SEI1.3	= Electro-proportional servo control 12V DC (AMP junior timer connector)	20
SEI2.3	= Electro-proportional servo control 24V DC (AMP junior timer connector)	20
SEI1.3D	= Electro-proportional servo control 12V DC (Deutsch connector)	23
SEI2.3D	= Electro-proportional servo control 24V DC (Deutsch connector)	23
SHIX	= Hydraulic servo control with feed back	26
SMIX	= Mechanical lever servo control with feed back	28
SEIX1.2	= Electro-proportional servo control with feed back 12V DC (AMP junior timer connector)	30
SEIX2.2	= Electro-proportional servo control with feed back 24V DC (AMP junior timer connector)	30
SEIX1.2D	= Electro-proportional servo control with feed back 12V DC (Deutsch connector)	33
SEIX2.2D	= Electro-proportional servo control with feed back 24V DC (Deutsch connector)	33
OA	7 - Control devices position = Position A	
OB	= Position B (for SEI versions available on request, please, contact our technical department for details).	
	8 - Relief valve settings 15 = 15 MPa 18 = 18 MPa 20 = 20 MPa 25 = 25 MPa 30 = 30 MPa 35 = 35 MPa	
00	9 - Boost pump = Without boost pump *	
14	= Standard boost pump 14 cm ³ /n - pressure 2 MPa (1000 n/min)	
14XX	= Boost pump 14 cm ³ /n - pressure 2 ÷ 3 MPa (1000 n/min) please contact our Tech. Dept.	
	* Upon order, please provide information on maximum external charge flow.	
SA	10 - Rear pump connection options = SAE-A 4 holes mounting flange (female shaft)	26
SB	= SAE-B 2 holes mounting flange (female shaft)	26
C-SA	= Closed (without rear fitting)	27

(continued)

ORDER CODE _____

000 **11- Auxiliary gear pump displacements**
= Without pump

Group 2 SAE A

204 = 4,2 cm ³ /n	206 = 6,0 cm ³ /n	209 = 8,4 cm ³ /n	211 = 10,8 cm ³ /n
214 = 14,4 cm ³ /n	217 = 16,8 cm ³ /n	219 = 19,2 cm ³ /n	222 = 22,8 cm ³ /n
226 = 26,2 cm ³ /n	230 = 30,0 cm ³ /n	240 = 40,0 cm ³ /n	

Group 3 SAE B

315 = 15,0 cm ³ /n	318 = 18,0 cm ³ /n	321 = 21 cm ³ /n	327 = 27,0 cm ³ /n
332 = 32,0 cm ³ /n	338 = 38,0 cm ³ /n	343 = 43,0 cm ³ /n	347 = 47,0 cm ³ /n
351 = 51,0 cm ³ /n	354 = 54,0 cm ³ /n	361 = 61,0 cm ³ /n	364 = 64,0 cm ³ /n
370 = 70,0 cm ³ /n	374 = 74,0 cm ³ /n	390 = 90,0 cm ³ /n	

12 - Optional

00	= Without optional	
SB	= Screw by-pass (Standard)	38
FR	= Pre-arranged for connection with external filter	39
MOB (SHI)	= Man on board with SHI Hydraulic servo control	40
MOB (SEI)	= Man on board with SEI Electro-proportional servo control	42
CO (--)	= Pressure cut-off valve (pressure setting)	44
G/J/M/-	= Port threads and restrictor diameter	

	Servo control type	Port threads	Symbol
STANDARD	SEI	Plugged	-
	SHI	1/4" BSPP	G
ON REQUEST	SHI	JIC (7/16" - 20)	J
	SHI	METRIC (M12x1,5)	M

Example G/08 = 1/4" BSPP port threads and Ø 0,8 mm restrictor (SHI)
Example -/08 = Ø 0,8 mm restrictor (SEI)

Restrictor diameter (SHI/SEI)	
-	Without restrictor
06	Restrictor orifice ø 0,6 mm
08	Restrictor orifice ø 0,8 mm
10	Restrictor orifice ø 1,0 mm
12	Restrictor orifice ø 1,2 mm
16	Restrictor orifice ø 1,6 mm
20	Restrictor orifice ø 2,0 mm

GENERAL DIMENSIONS/PUMP PORTS

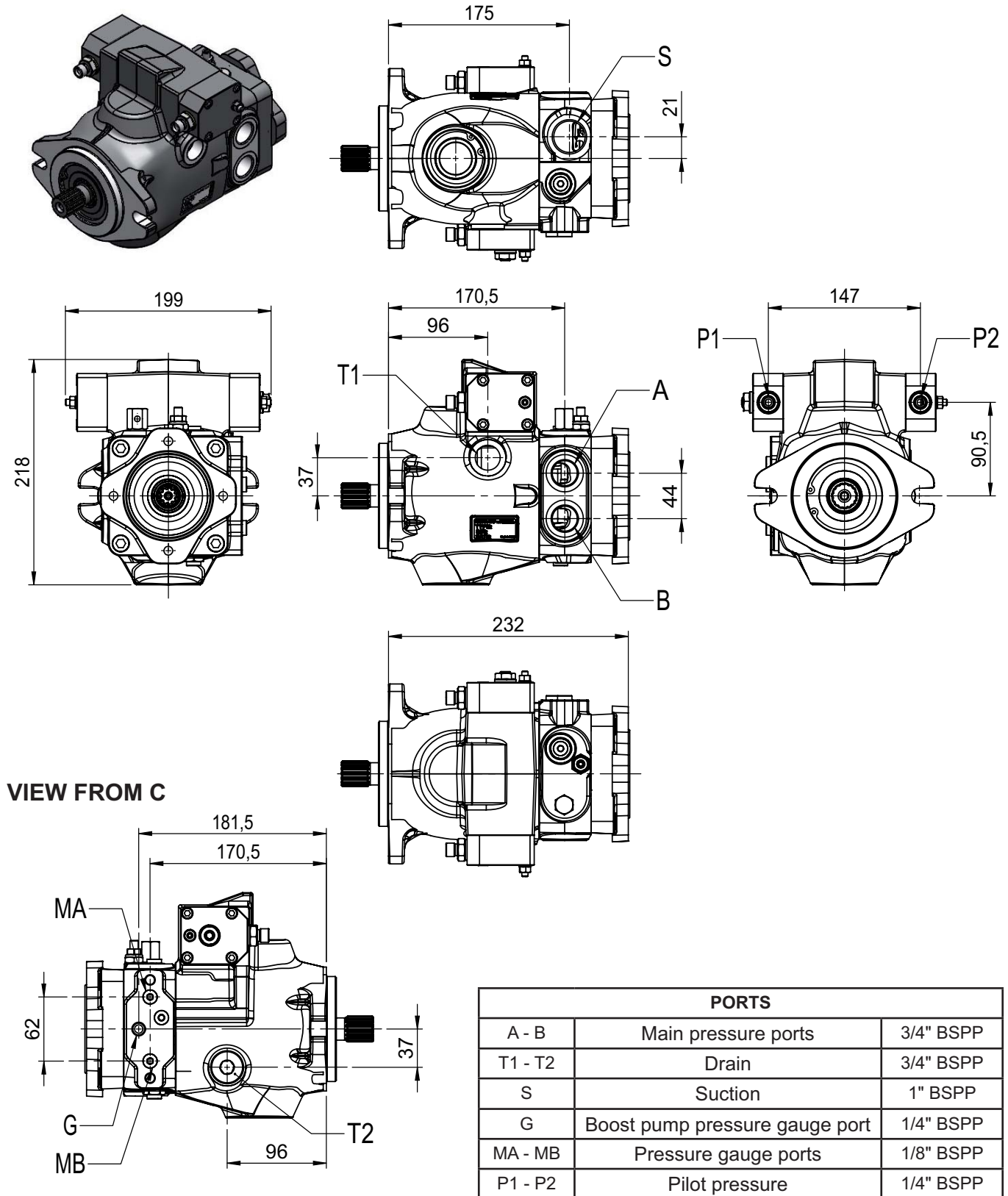

SHAFT OPTION AND MOUNTING FLANGE

SS3

SPLINED SHAFT 13T

Norm SAE-B ANSI B92.2-1970 CLASS 5
Max. torque = 320Nm

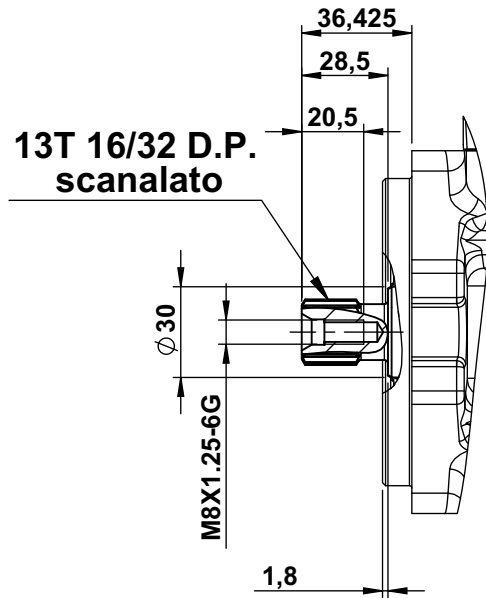

SS5

SPLINED SHAFT SAE-BB Z = 15

Max. torque = 450 Nm

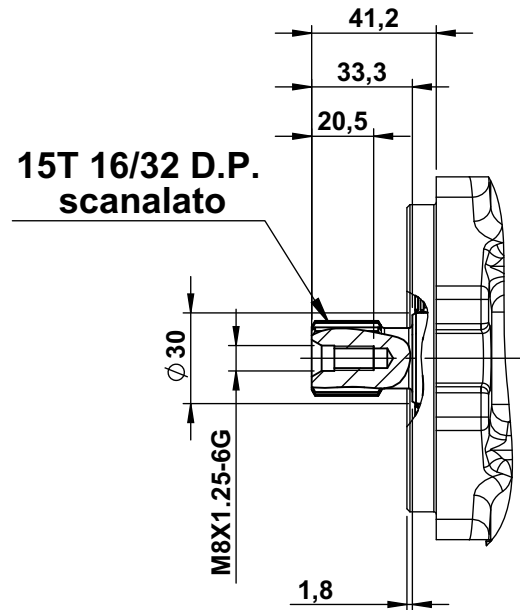

Caution: in case of multiple pump applications the total torque requested must be limited to the above value.

F2.2

FLANGE SAE-B - 2 BOLT

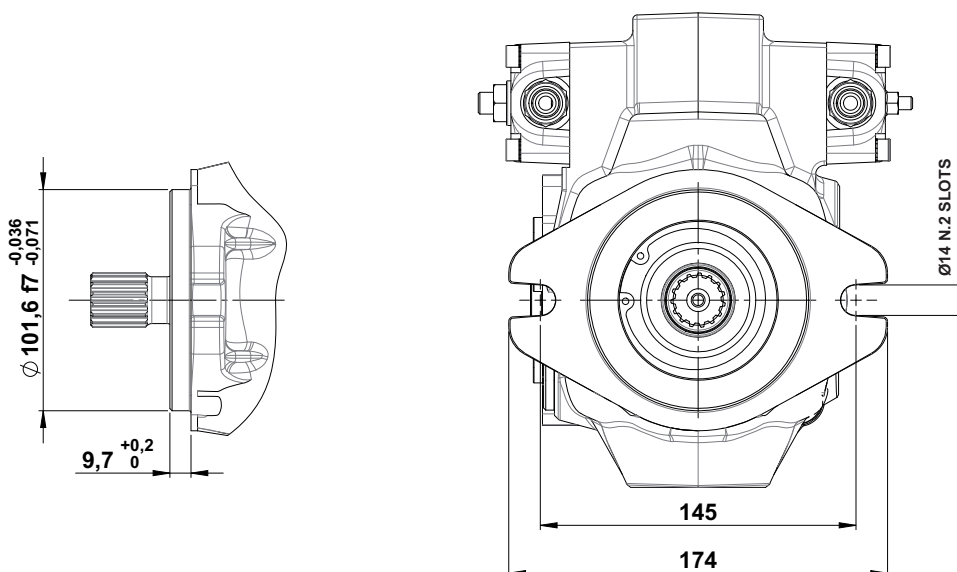

SHI

HYDRAULIC SERVO CONTROL

The pump displacement variation is obtained by adjusting the pressure on P1 and P2 servo control ports by means of a hydraulic proportional joystick (with integrated pressure reducing valves).

The servo control supply can be obtained by taking pressure from the boost pump (G port), see pag. 16.

The servo control return time can be adjusted

by inserting a restrictor on the joystick supply line (0,5 ÷ 1,2 mm).

The servo control operation curve, in both directions, goes from 0,4 to 1,8 MPa (tolerance $\pm 5\%$).

The adjusting curve of the hydraulic joystick has to be a little wider (0,3 ÷ 1,9 MPa).

Suggested curves for HPV series Joysticks: CR062 (see HT 73/B/105/0417/E catalogue).

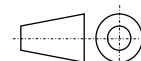
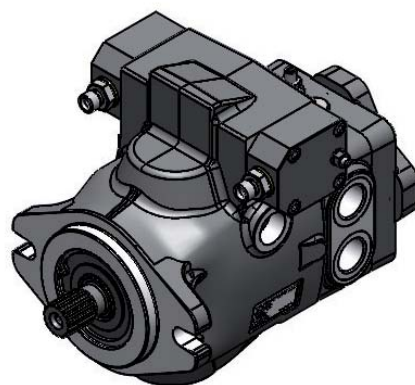
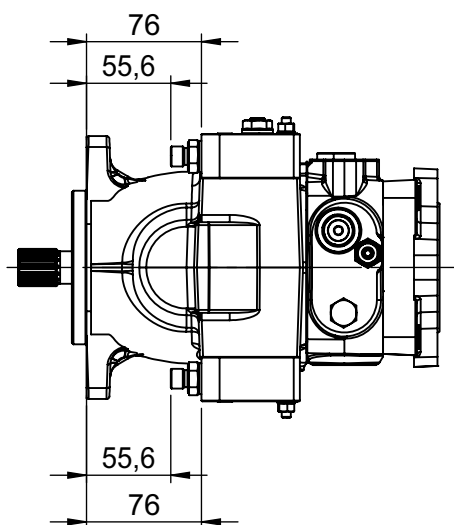
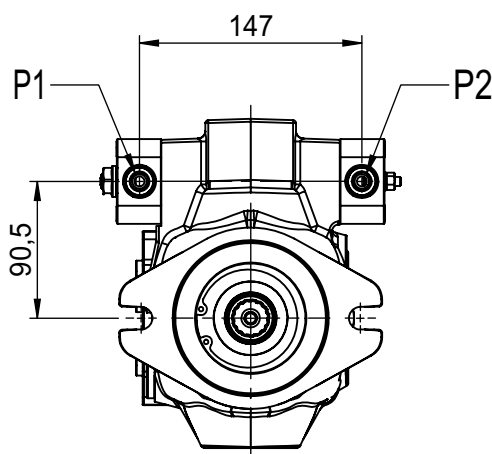
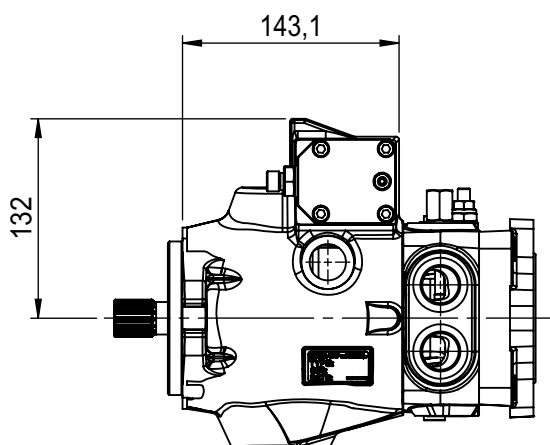

SEI 1.3 (12V DC)

SEI 2.3 (24V DC)

ELECTRO-PROPORTIONAL SERVO CONTROL

(AMP junior timer connector)

The pump displacement variation is obtained by an electric signal, which varies approx.:

- from 315 to 630 mA (24V DC voltage)
- from 630 to 1260 mA (12V DC voltage)

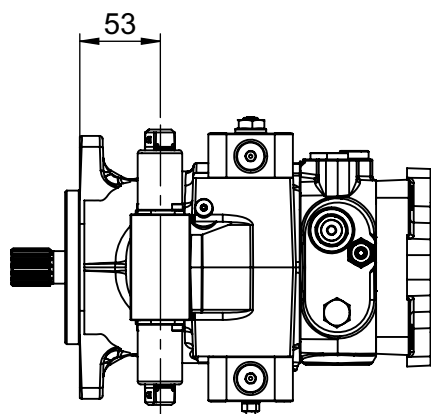
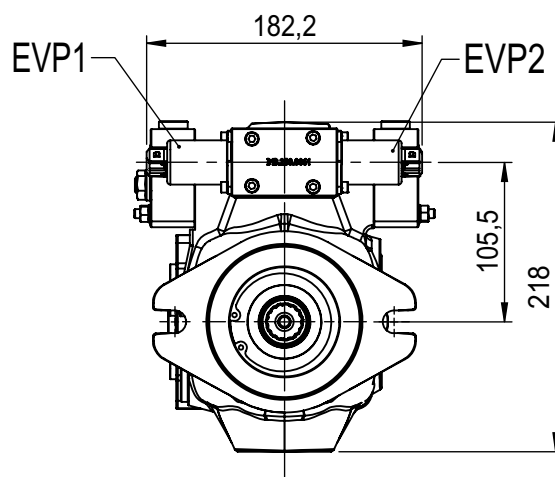
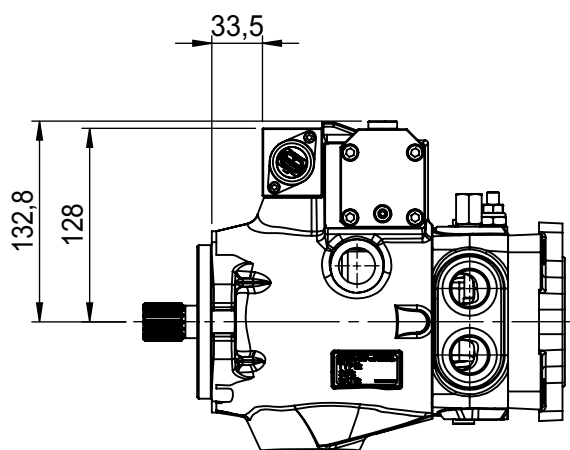

(continued)

SEI 1.3 (12V DC)

SEI 2.3 (24V DC)

ELECTRO-PROPORTIONAL SERVO CONTROL

(AMP junior timer connector)

HYDRAULIC DIAGRAM

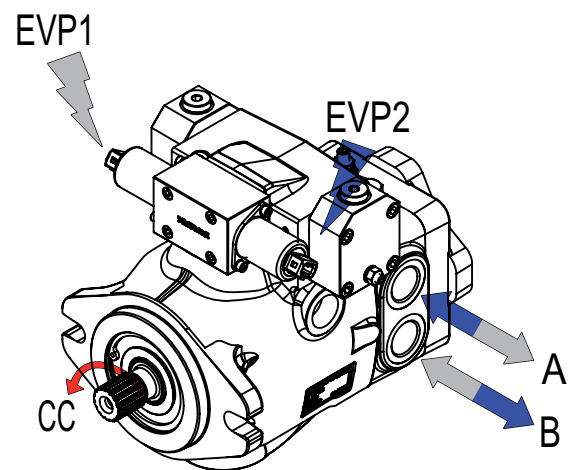
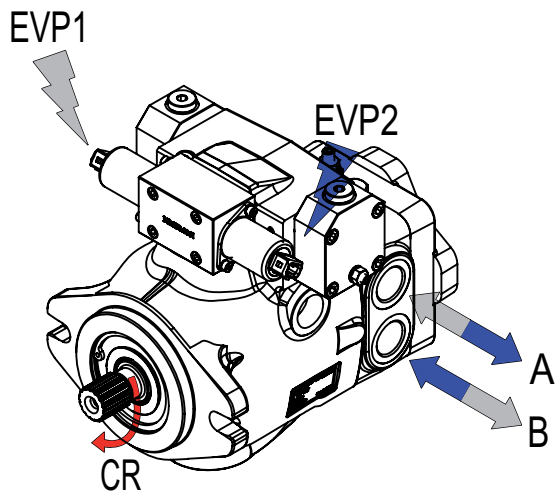
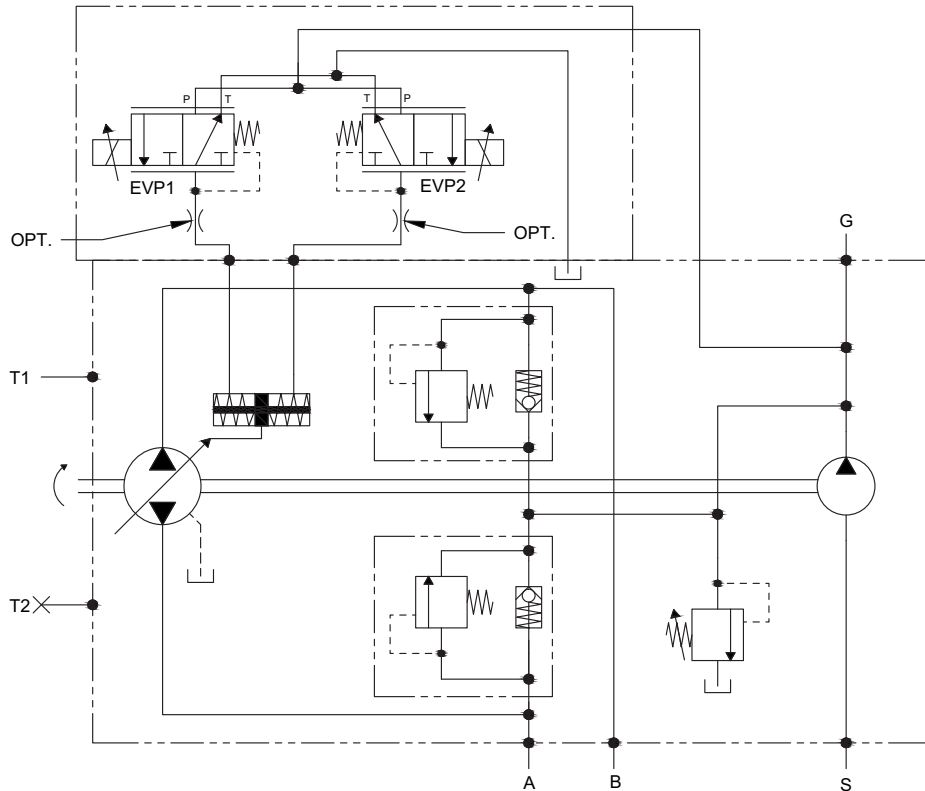

(continued)

SEI 1.3 (12V DC)

SEI 2.3 (24V DC)

ELECTRO-PROPORTIONAL SERVO CONTROL

(AMP junior timer connector)

CURRENT-DISPLACEMENT GRAPHIC

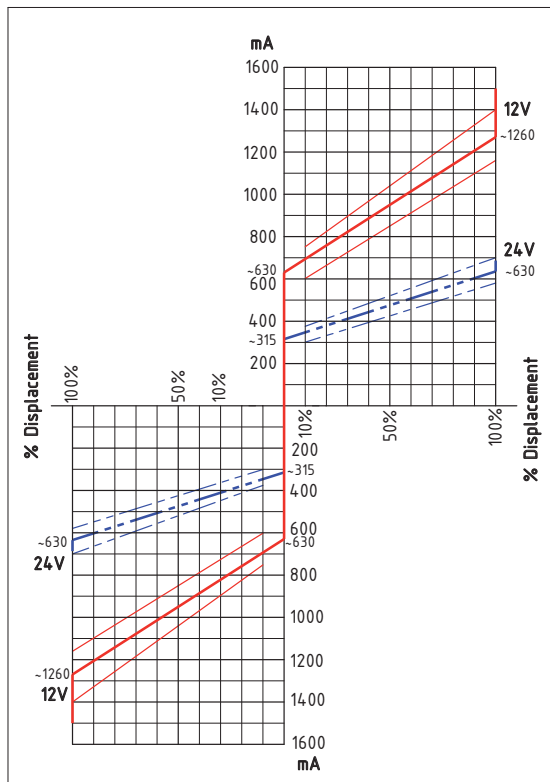

SOLENOID VALVE ELECTRICAL FEATURES		
Voltage	12 V DC	24 V DC
Electric current	1500 mA	750 mA
Load resistance	4,72 Ω ± 5%	20,8 Ω ± 5%
Type of control	Current control PWM 100 Hz (suggested)	
Type of connection	AMP Junior Timer	
Protection class	Until IP6K6 / IPX9K	

SOLENOID VALVE HYDRAULIC FEATURES	
Max. pressure (P, T)	pP= 5 MPa, pT= 3 MPa
Hysteresis (w/PWM)	<0,07 MPa (pA=2,0)
	<0,1 MPa (pA=2,5)
	<0,15 MPa (pA=3,5)
Filtration ratio	125 μm
Oil contamination level	Min. filtration ratio: 20/18/15
	According ISO 4406
	Hydraulic oil DIN 51524
Min./max. oil temperature	From -20 to +90°C

SEI 1.3D (12V DC)
SEI 2.3D (24V DC)

ELECTRO-PROPORTIONAL SERVO CONTROL
(Deutsch connector)

The pump displacement variation is obtained by an electric signal, which varies approx.:

- from 315 to 630 mA (24V DC voltage)
- from 630 to 1260 mA (12V DC voltage)

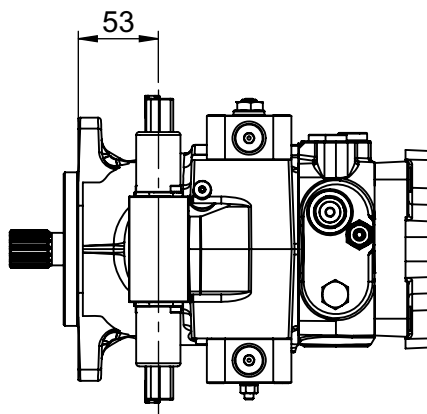
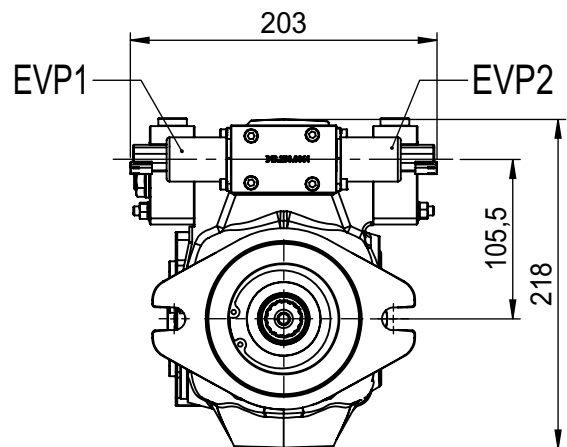
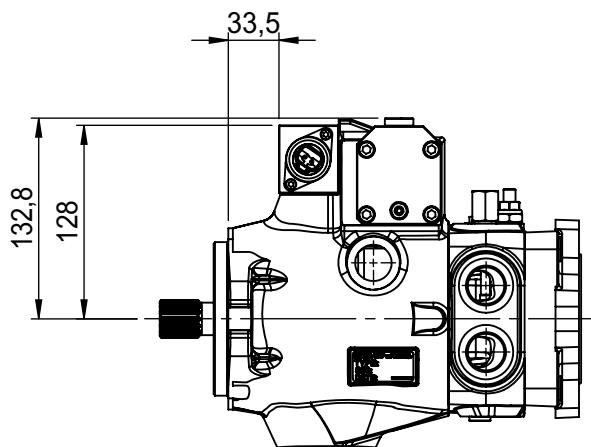

(continued)

SEI 1.3D (12V DC)

SEI 2.3D (24V DC)

ELECTRO-PROPORTIONAL SERVO CONTROL

(Deutsch connector)

HYDRAULIC DIAGRAM

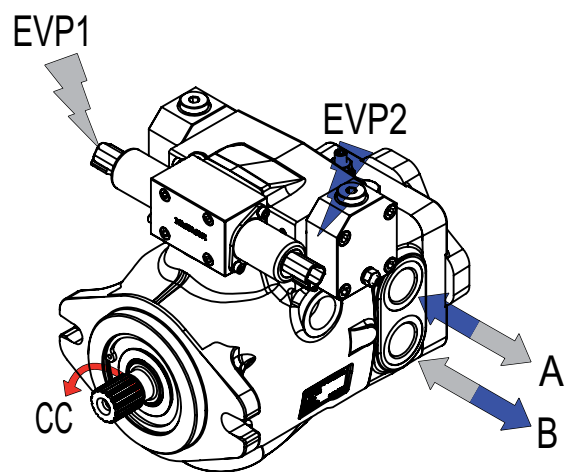
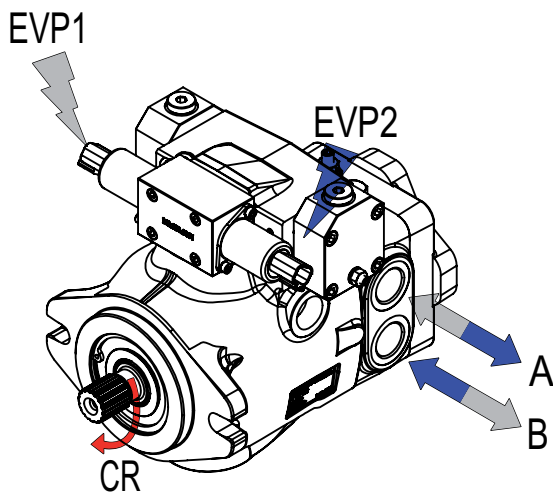
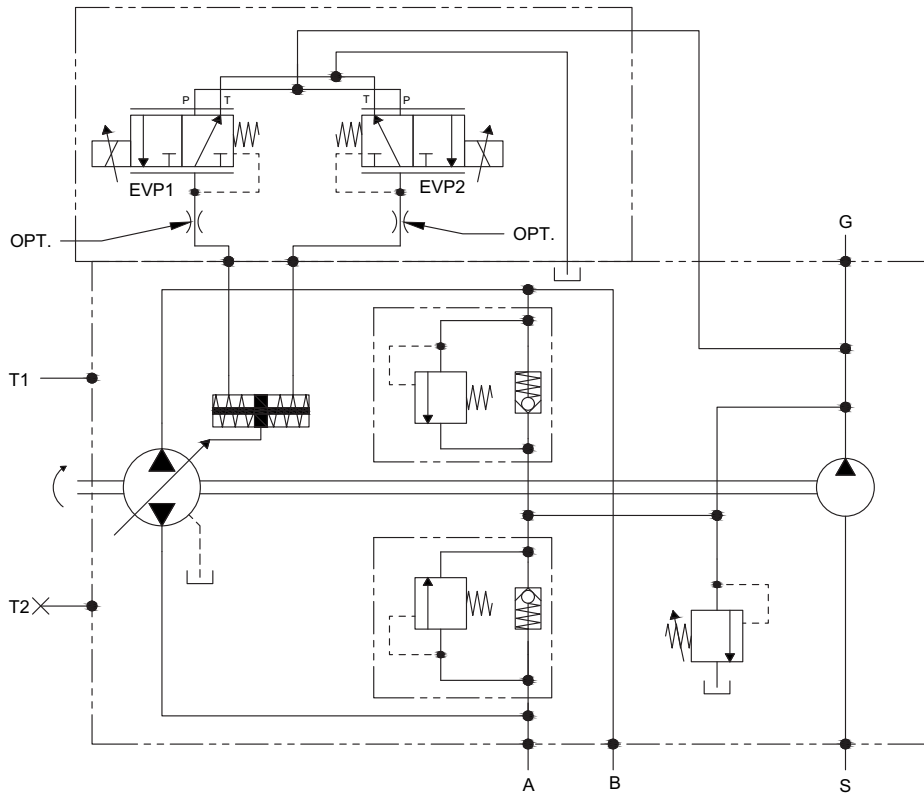

(continued)

SEI 1.3D (12V DC)

SEI 2.3D (24V DC)

ELECTRO-PROPORTIONAL SERVO CONTROL

(Deutsch connector)

CURRENT-DISPLACEMENT GRAPHIC

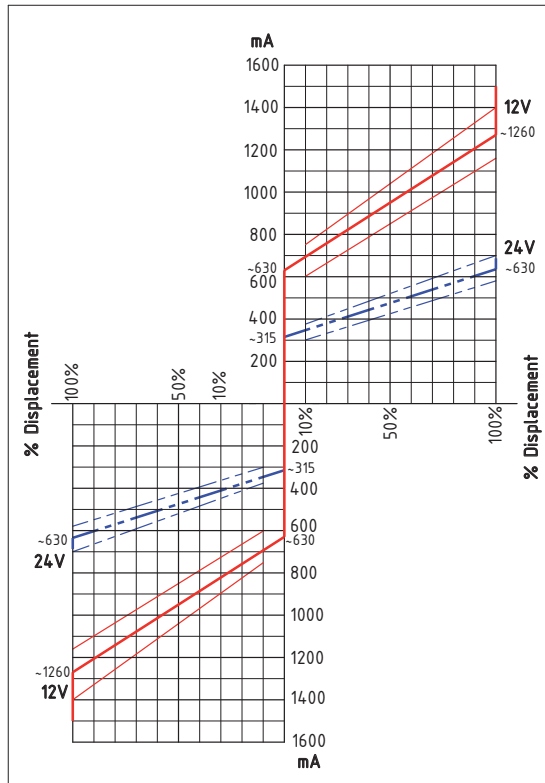

SOLENOID VALVE ELECTRICAL FEATURES		
Voltage	12 V DC	24 V DC
Electric current	1500 mA	750 mA
Load resistance	4,72 Ω ± 5%	20,8 Ω ± 5%
Type of control	Current control	
	PWM 100 Hz (suggested)	
Type of connection	DEUTSCH DT 04-2P	
Protection class	Until IP6K6 / IPX9K	

SOLENOID VALVE HYDRAULIC FEATURES	
Max. pressure (P, T)	pP= 5 MPa, pT= 3 MPa
Hysteresis (w/PWM)	<0,07 MPa (pA=2,0)
	<0,1 MPa (pA=2,5)
	<0,15 MPa (pA=3,5)
Filtration ratio	125 µm
Oil contamination level	Min. filtration ratio: 20/18/15
	According ISO 4406
	Hydraulic oil DIN 51524
Min./max. oil temperature	From -20 to +90°C

SHIX

HYDRAULIC SERVO CONTROL WITH FEED BACK

The pump displacement variation is obtained by adjusting the pressure on P1 and P2 servo control ports by means of a hydraulic proportional joystick (with integrated pressure reducing valves).

The servo control oil supply can be obtained by taking pressure from the boost pump (G port), see page 16.

The servo control return time can be adjusted by inserting a restrictor on the joystick supply line (0,5 ÷ 1,2 mm).

The servo control operation curve, in both directions, goes from 0,4 to 2 MPa (tolerance $\pm 5\%$).

The adjusting curve of the hydraulic joystick has to be a little wider (0,3 ÷ 2,1 MPa).

Suggested curves for HPV series Joysticks: CR096 (see HT 73/B/105/0417/E catalogue).

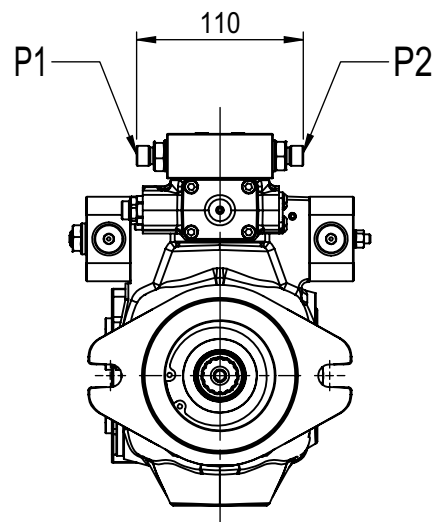
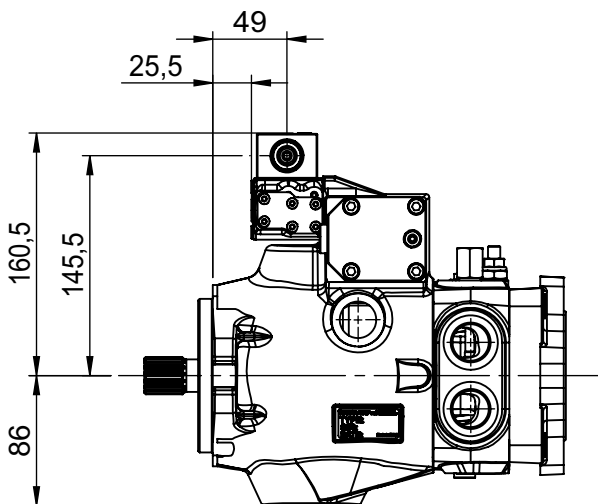

(continued)

SHIX

HYDRAULIC SERVO CONTROL WITH FEED BACK

HYDRAULIC DIAGRAM

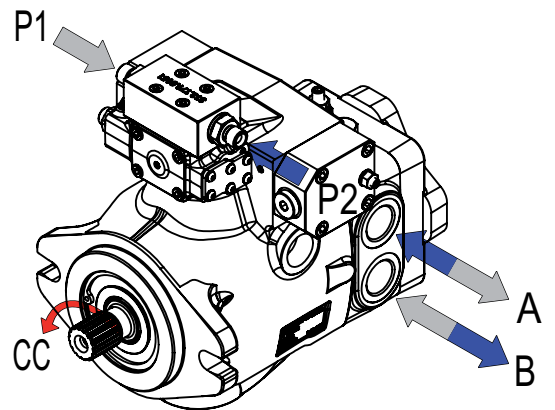
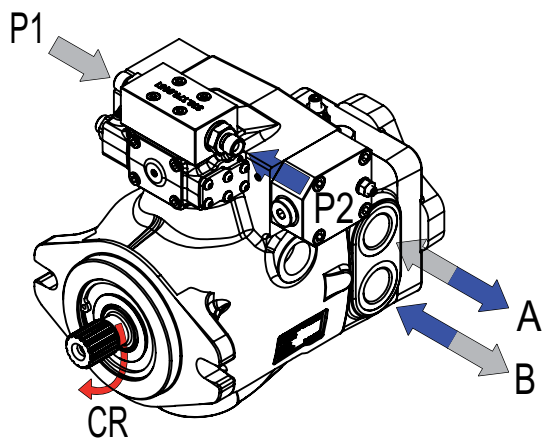
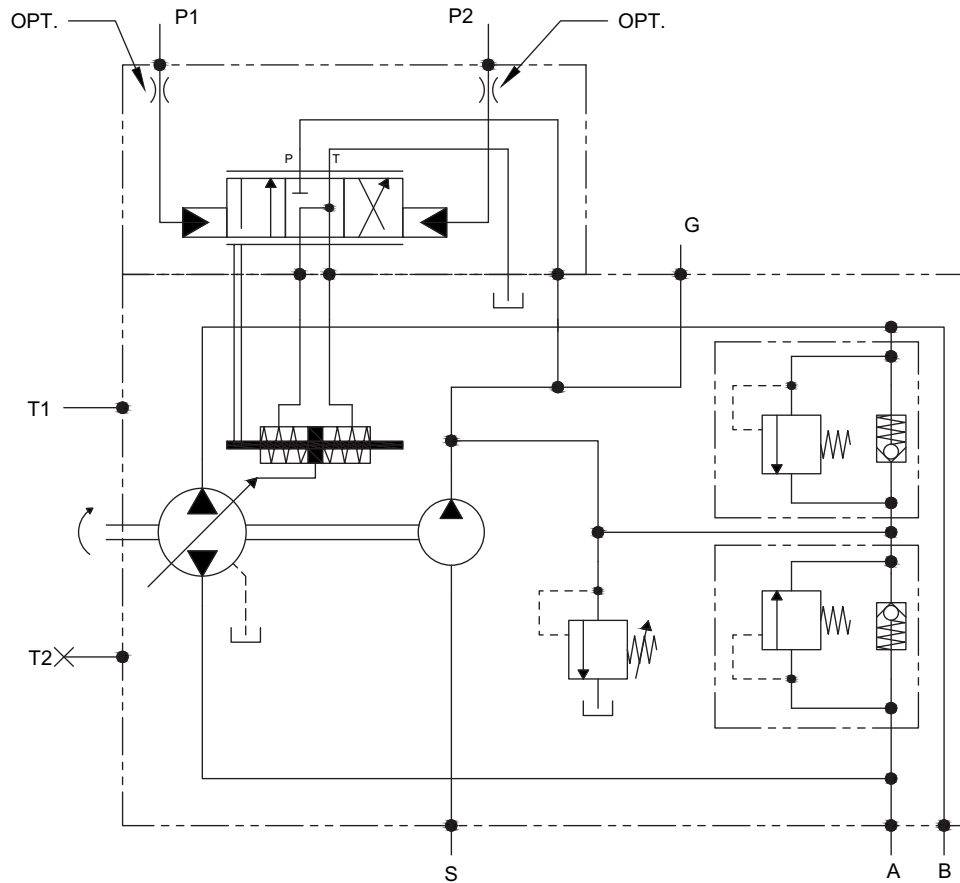

SMIX

MANUAL LEVER CONTROL WITH FEED BACK

The pump displacement variation is directly related to the angle position of the lever.

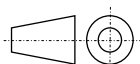
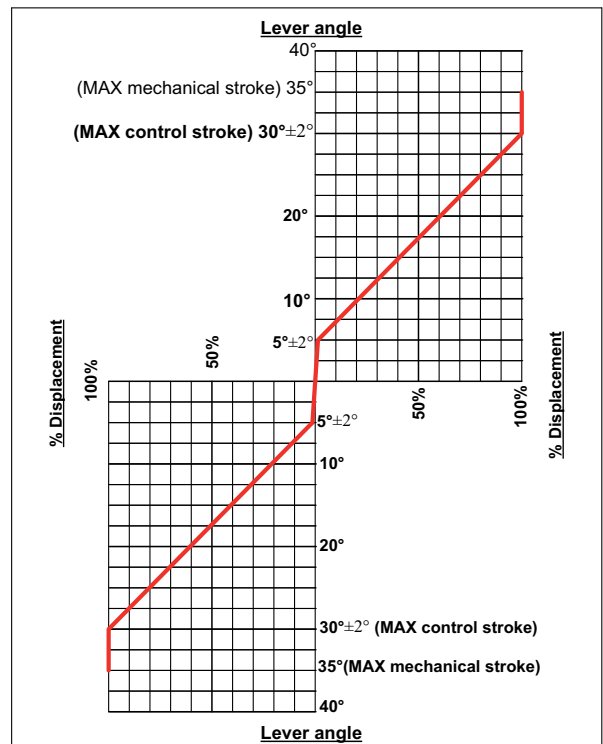
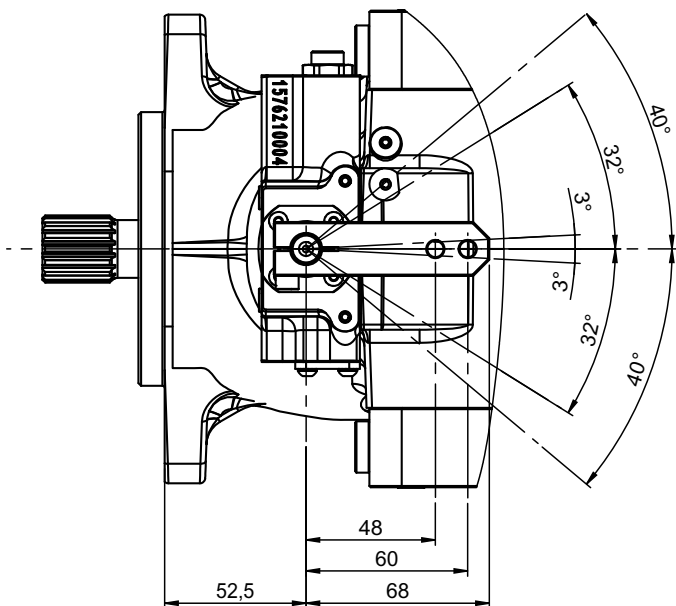
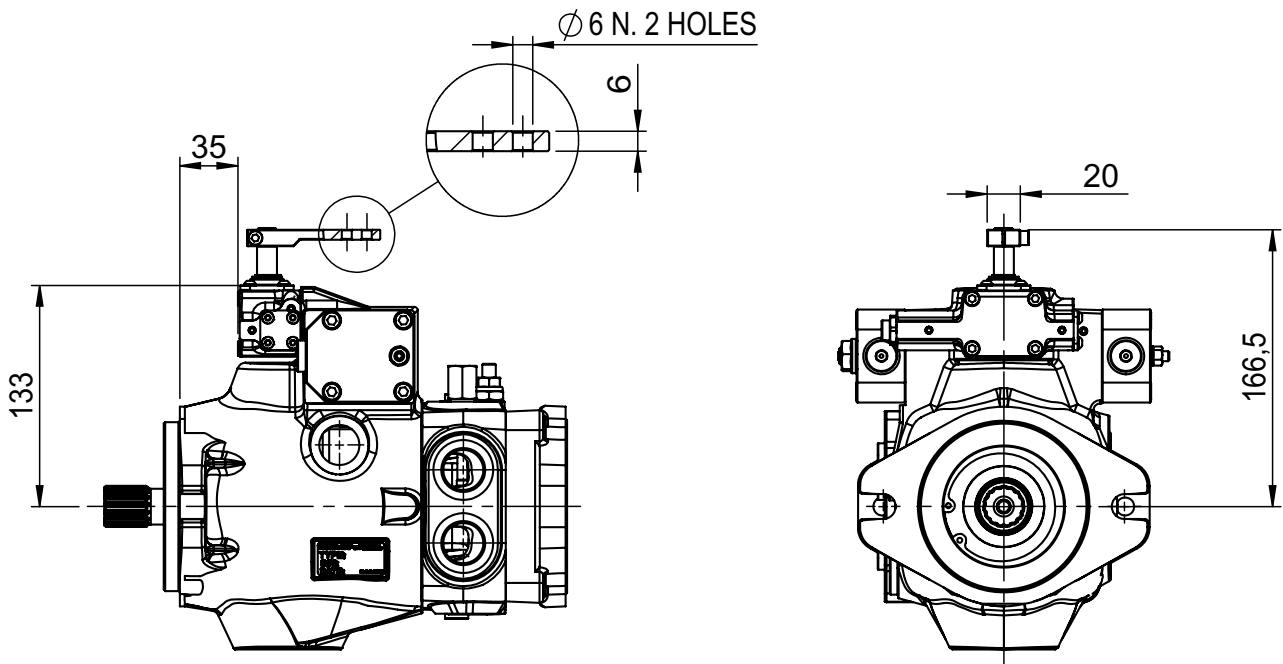

(continued)

SMIX

MANUAL LEVER CONTROL WITH FEED BACK

HYDRAULIC DIAGRAM

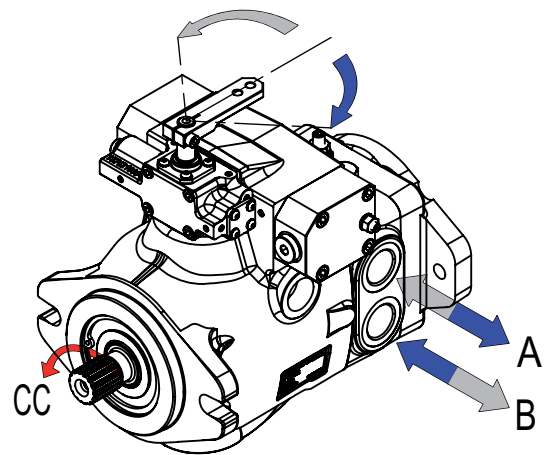
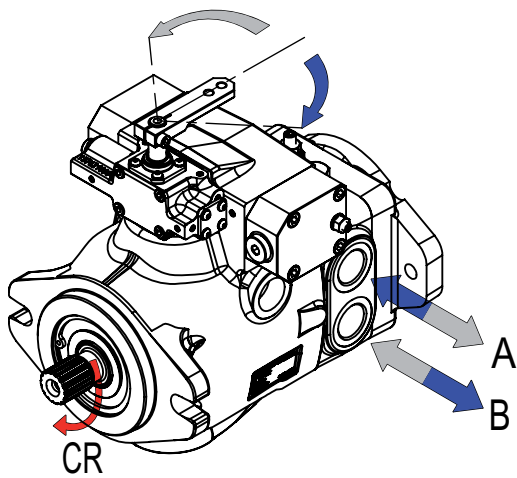
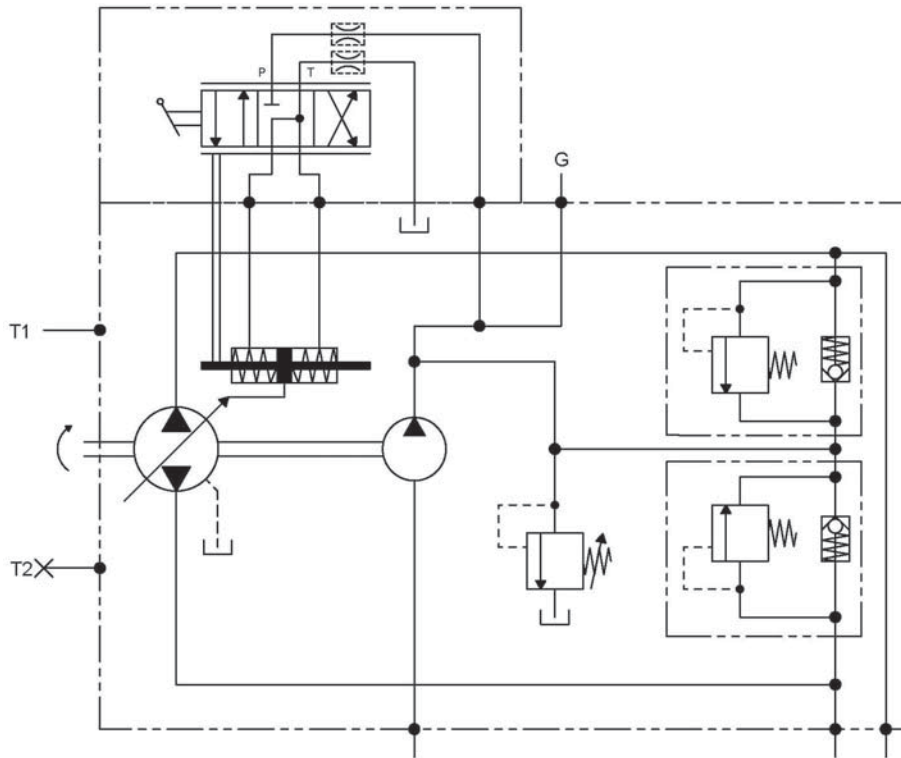

SEIX 1.2 (12V DC)**SEIX 2.2** (24V DC)**ELECTRO-PROPORTIONAL SERVO CONTROL WITH FEED BACK**

(AMP junior timer connector)

The pump displacement variation is obtained by an electric signal, which varies approx.:

- from 315 to 630 mA (24V DC voltage)
- from 630 to 1260 mA (12V DC voltage)

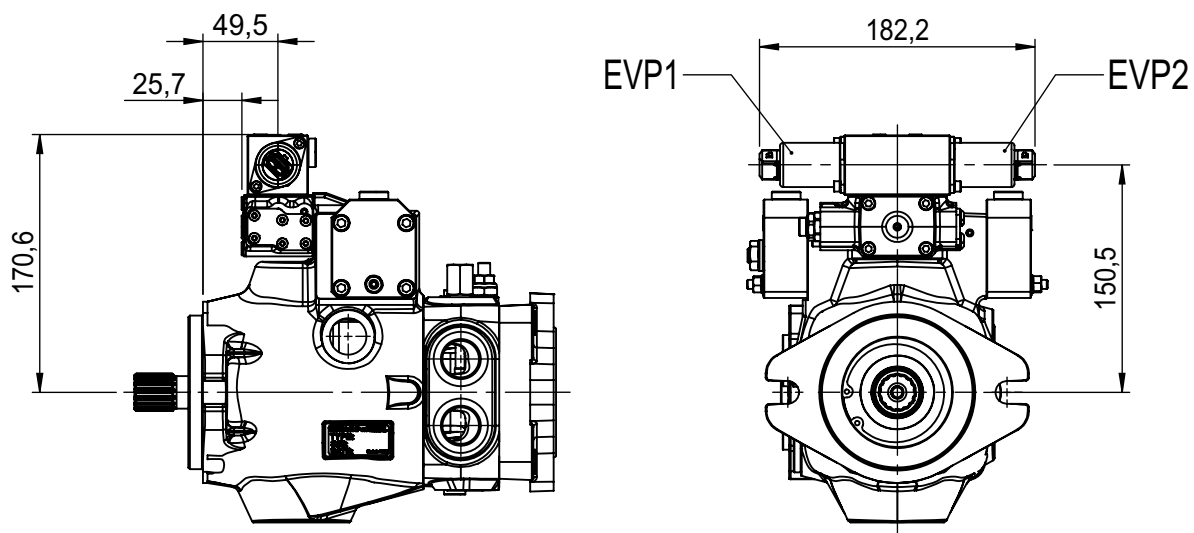

(continued)

SEIX 1.2 (12V DC)
SEIX 2.2 (24V DC)

ELECTRO-PROPORTIONAL SERVO CONTROL WITH FEED BACK

(AMP junior timer connector)

HYDRAULIC DIAGRAM

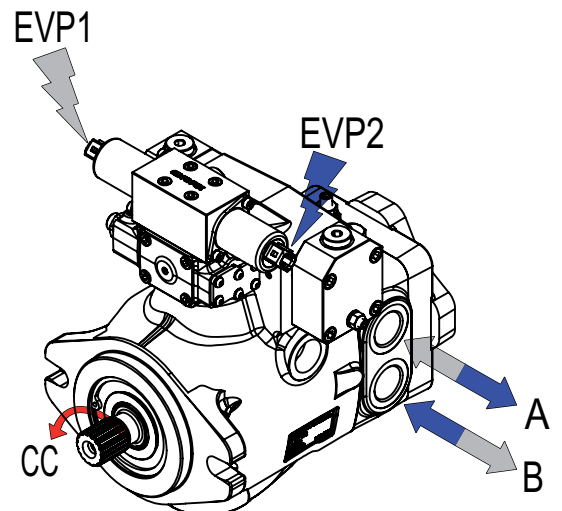
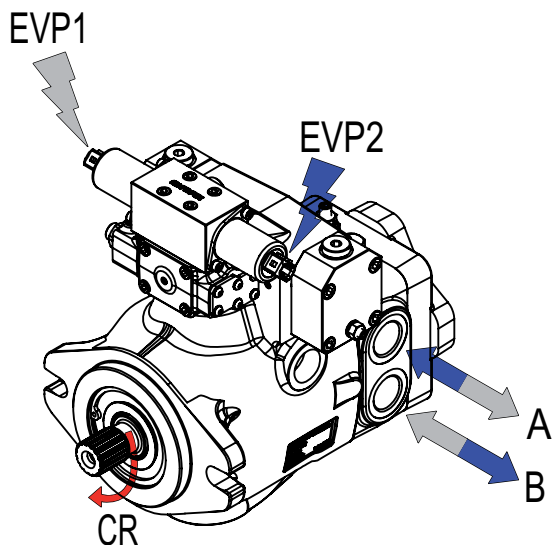
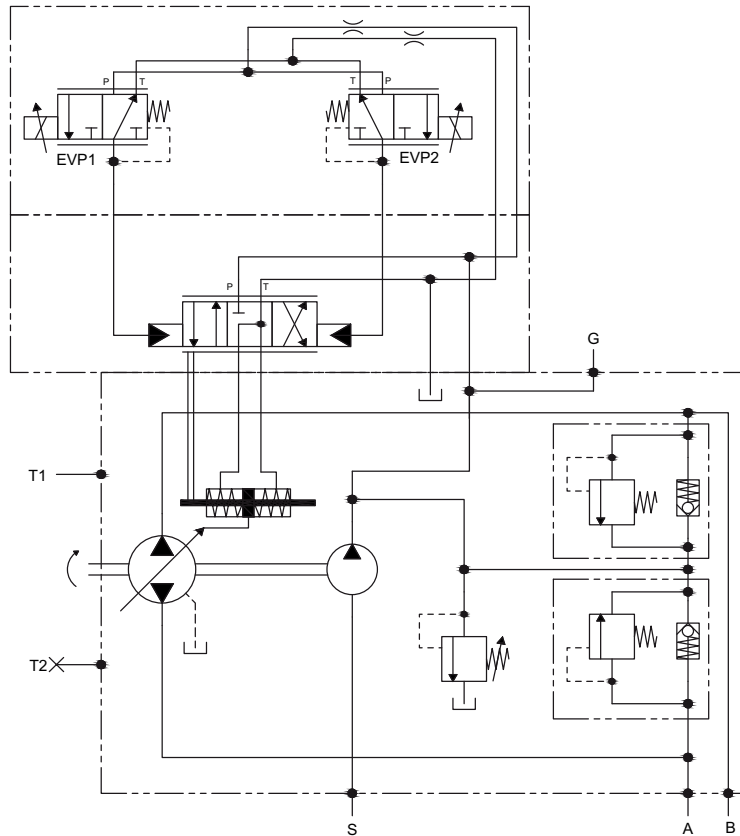

(continued)

SEIX 1.2 (12V DC)
SEIX 2.2 (24V DC)

ELECTRO-PROPORTIONAL SERVO CONTROL WITH FEED BACK

(AMP junior timer connector)

CURRENT-DISPLACEMENT GRAPHIC

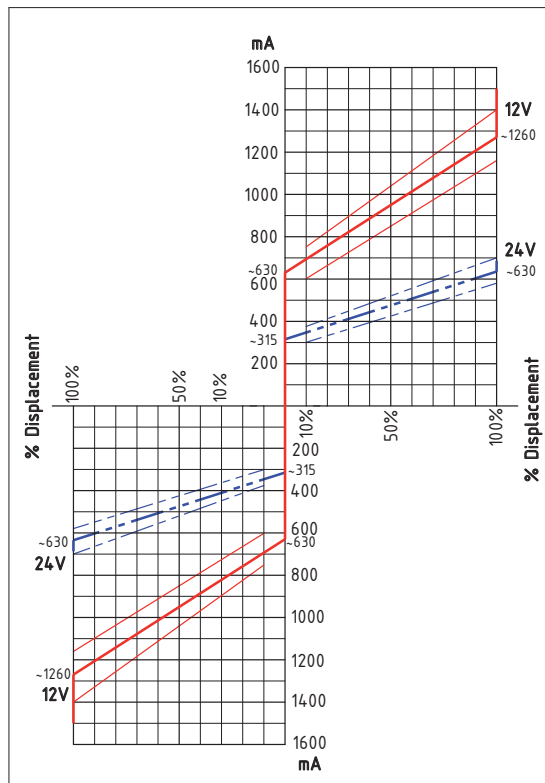

SOLENOID VALVE ELECTRICAL FEATURES		
Voltage	12 V DC	24 V DC
Electric current	1500 mA	750 mA
Load resistance	4,72 Ω ± 5%	20,8 Ω ± 5%
Type of control	Current control	
	PWM 100 Hz (suggested)	
Type of connection	DEUTSCH DT 04-2P	
Protection class	Until IP6K6 / IPX9K	

SOLENOID VALVE HYDRAULIC FEATURES	
Max. pressure (P, T)	pP= 5 MPa, pT= 3 MPa
Hysteresis (w/PWM)	<0,07 MPa (pA=2,0)
	<0,1 MPa (pA=2,5)
	<0,15 MPa (pA=3,5)
Filtration ratio	125 μm
Oil contamination level	Min. filtration ratio: 20/18/15
	According ISO 4406
	Hydraulic oil DIN 51524
Min./max. oil temperature	From -20 to +90°C

SEIX 1.2D (12V DC)
SEIX 2.2D (24V DC)**ELECTRO-PROPORTIONAL SERVO CONTROL WITH FEED BACK**

(Deutsch connector)

The pump displacement variation is obtained by an electric signal, which varies approx.:

- from 315 to 630 mA (24V DC voltage)
- from 630 to 1260 mA (12V DC voltage)

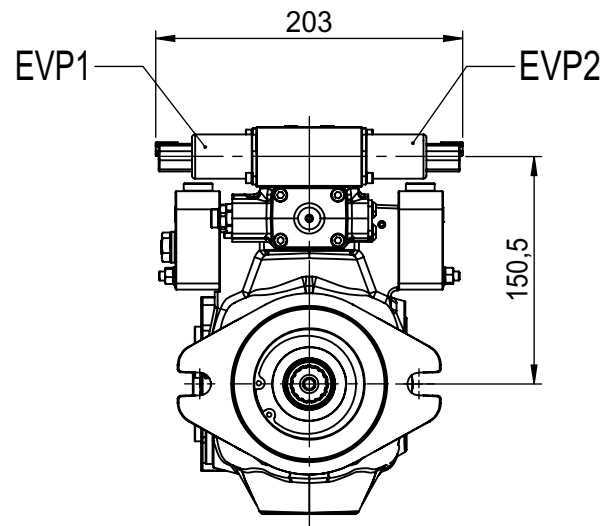
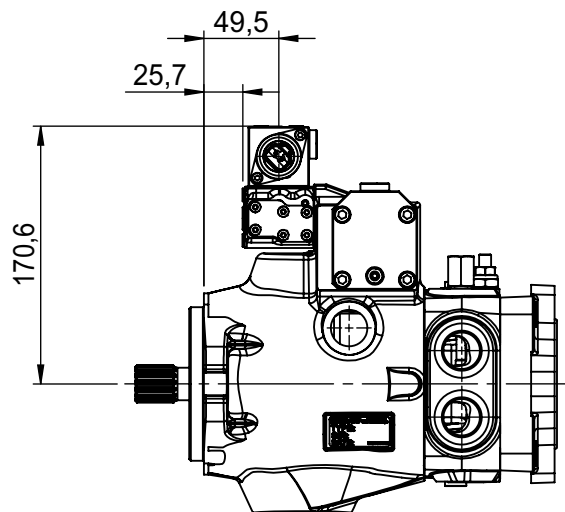

(continued)

SEIX 1.2D (12V DC)

SEIX 2.2D (24V DC)

ELECTRO-PROPORTIONAL SERVO CONTROL WITH FEED BACK

(Deutsch connector)

HYDRAULIC DIAGRAM

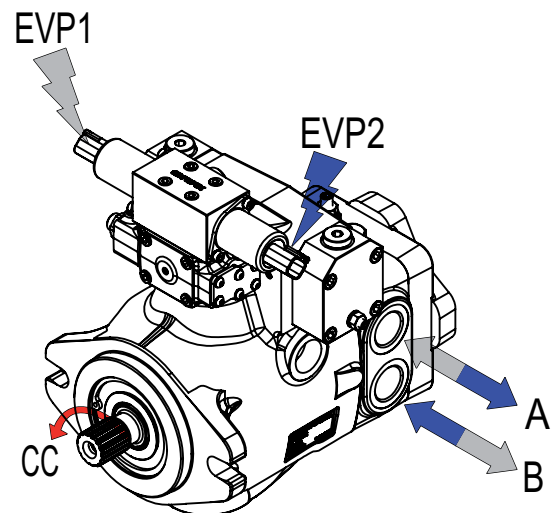
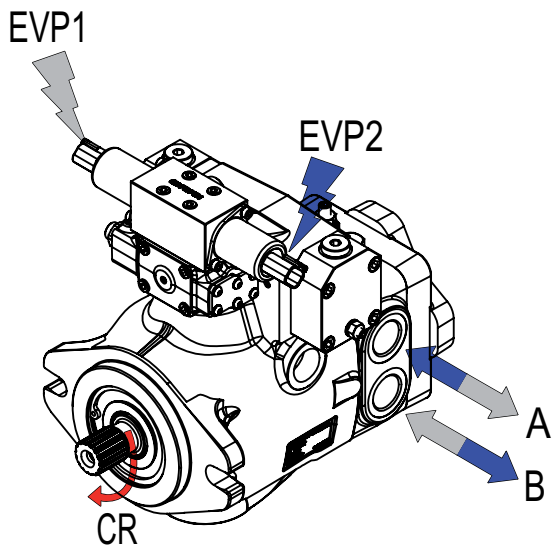
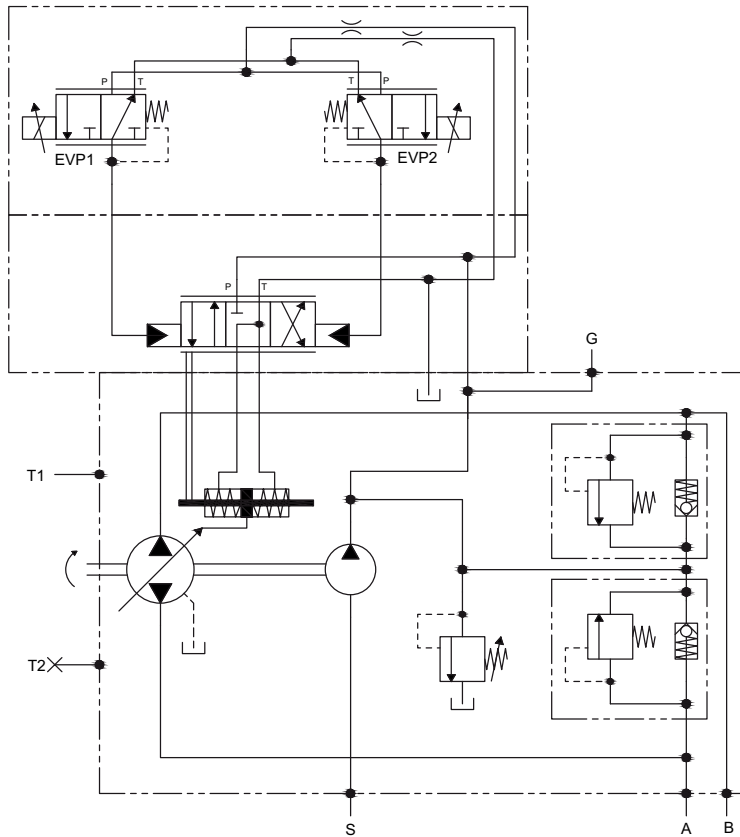

(continued)

SEIX 1.2D (12V DC)
SEIX 2.2D (24V DC)

ELECTRO-PROPORTIONAL SERVO CONTROL WITH FEED BACK

(Deutsch connector)

CURRENT-DISPLACEMENT GRAPHIC

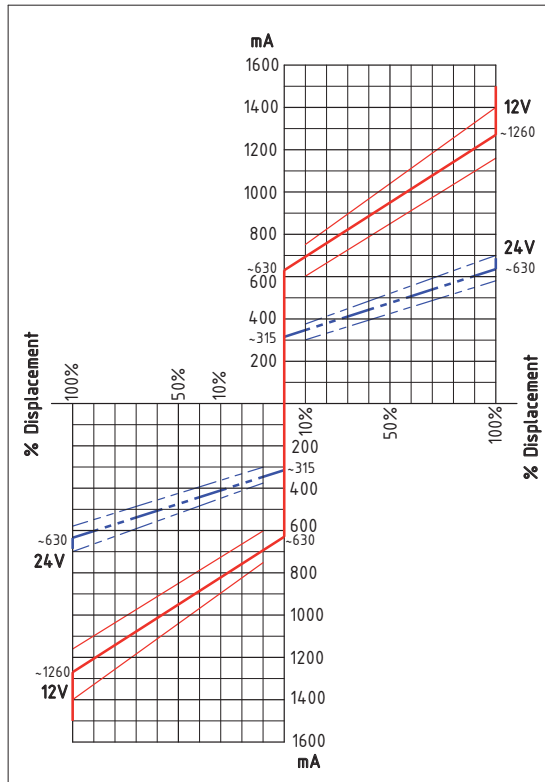

ELECTRICAL FEATURES		
Voltage	12 V DC	24 V DC
Electric current	1500 mA	750 mA
Load resistance	4,72 Ω ± 5%	20,8 Ω ± 5%
Type of control	Current control PWM 100 Hz (suggested)	
Type of connection	AMP Junior Timer	
Protection class	Until IP6K6 / IPX9K	

HYDRAULIC FEATURES	
Max. pressure (P, T)	pP= 5 MPa, pT= 3 MPa
Hysteresis (w/PWM)	<0,07 MPa (pA=2,0)
	<0,1 MPa (pA=2,5)
	<0,15 MPa (pA=3,5)
Filtration ratio	125 µm
Oil contamination level	Min. filtration ratio: 20/18/15
	According ISO 4406
	Hydraulic oil DIN 51524
Min./max. oil temperature	From -20 to +90°C

REAR PUMP MOUNTING FLANGES

SA

SAE-A - 4 HOLES

Max. torque = 120 Nm

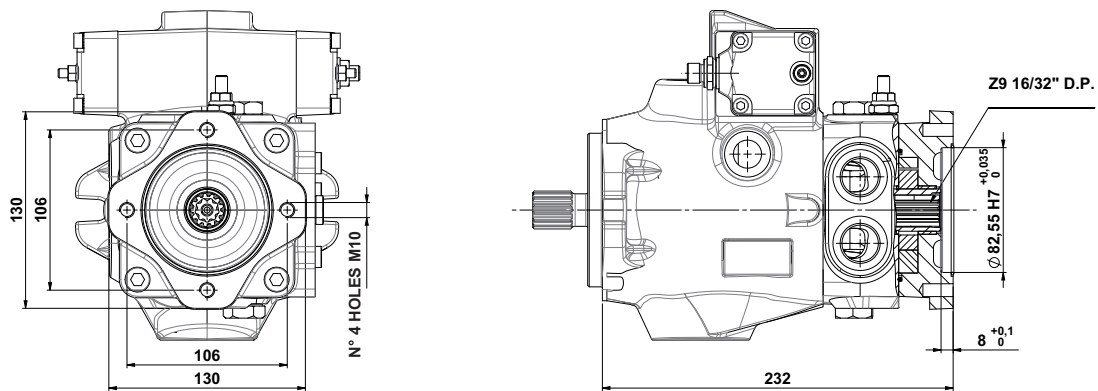

SB

SAE-B - 2 HOLES

Max. torque = 300 Nm

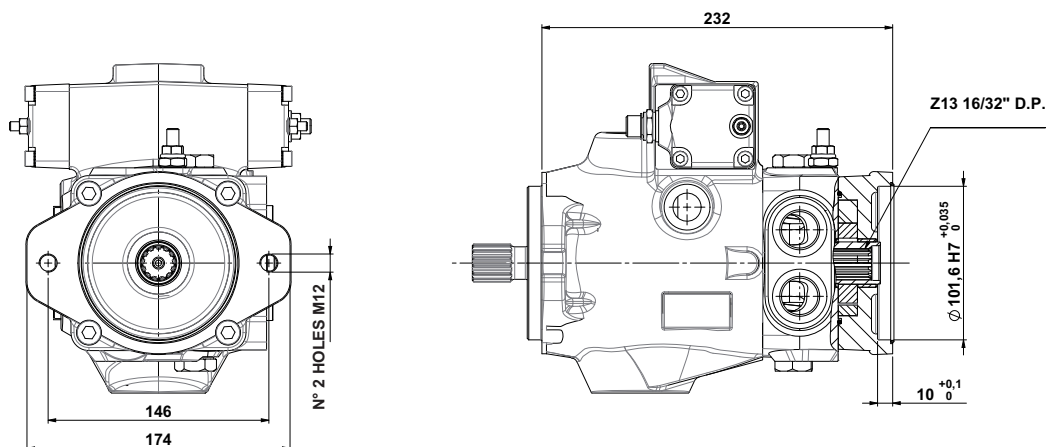

(continued)

REAR PUMP MOUNTING FLANGES

C-SA

CLOSED COVER WITHOUT REAR FITTING

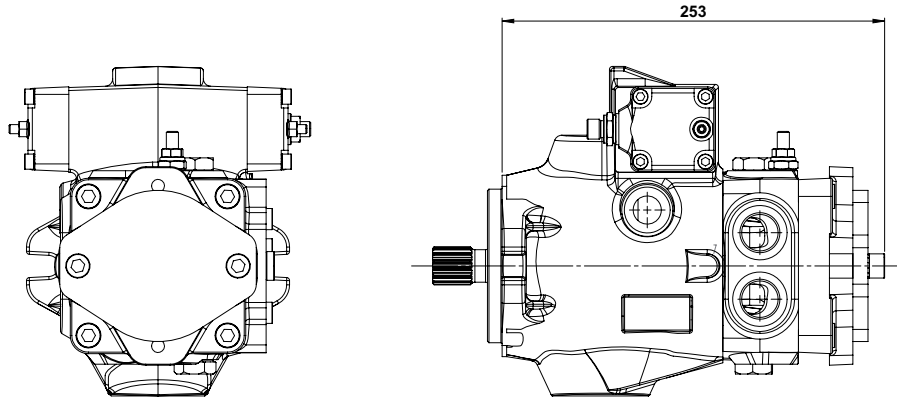

OPTIONAL SB

SCREW BY- PASS

To by pass the oil flow from one direction to the other, with the pump not running or in emergency condition, a by pass screw can be actuated to connect the 2 lines of the hydraulic system. The orifice is completely open after 4 counter-clockwise rotations of the screw.

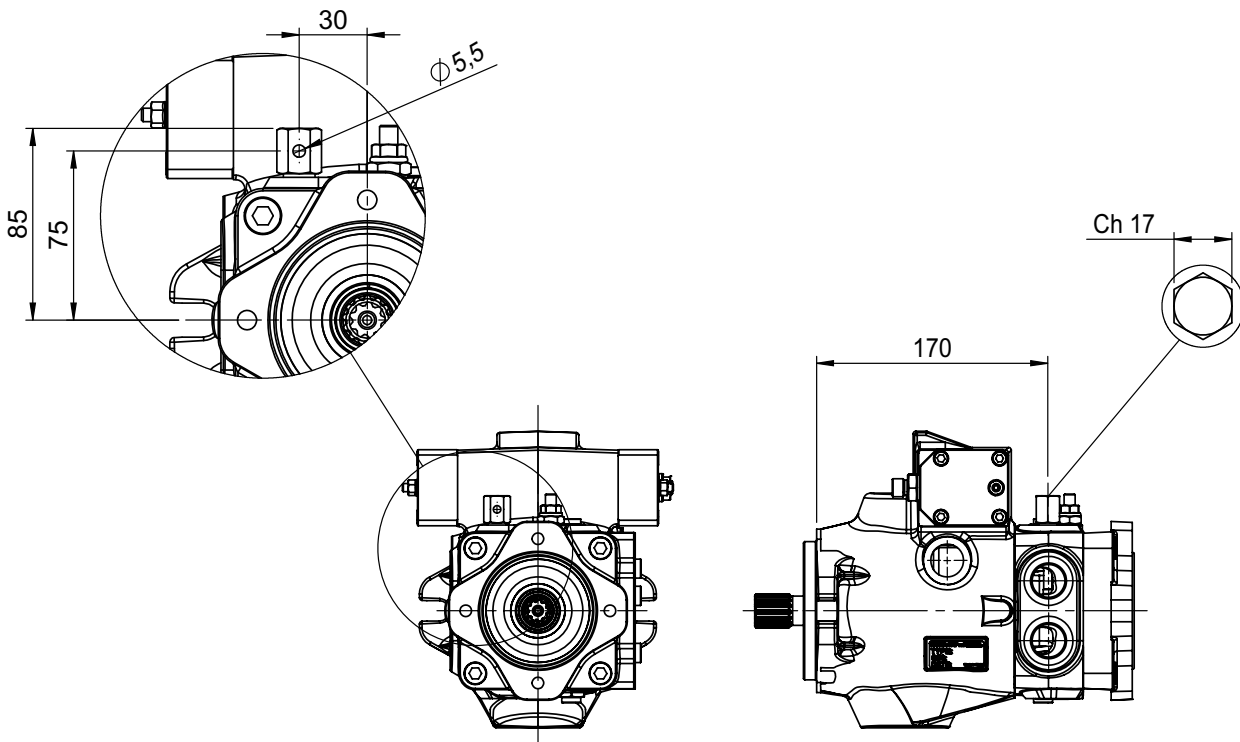

HYDRAULIC DIAGRAM

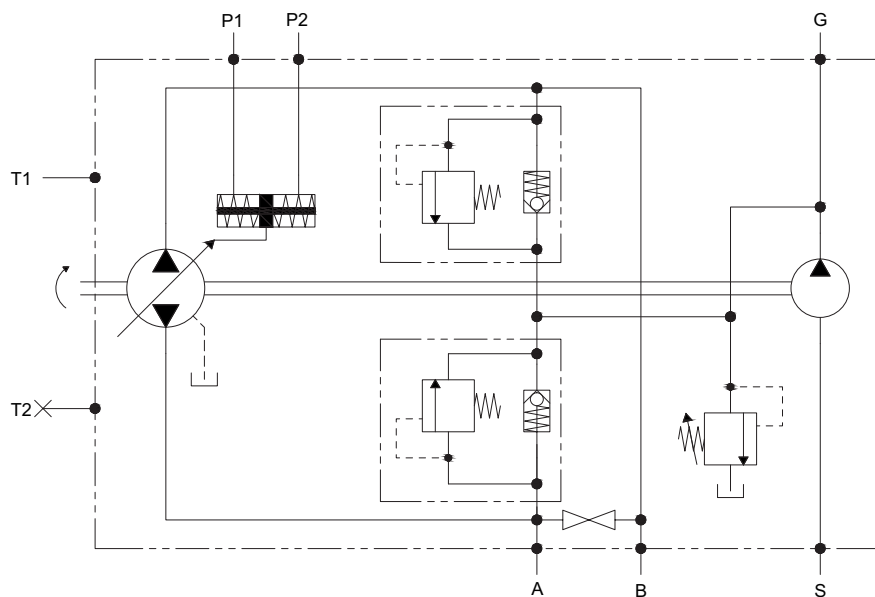

OPTIONAL FR

PRE-ARRANGED FOR CONNECTION WITH EXTERNAL FILTER

The pre-arrangement for the connection with an external filter allows the filtration of the oil of the boost pump under pressure.

The filter is not included and must be with a by-pass, filtration level 10 µm and must be of suitable size for the flow-rate of the boost pump.

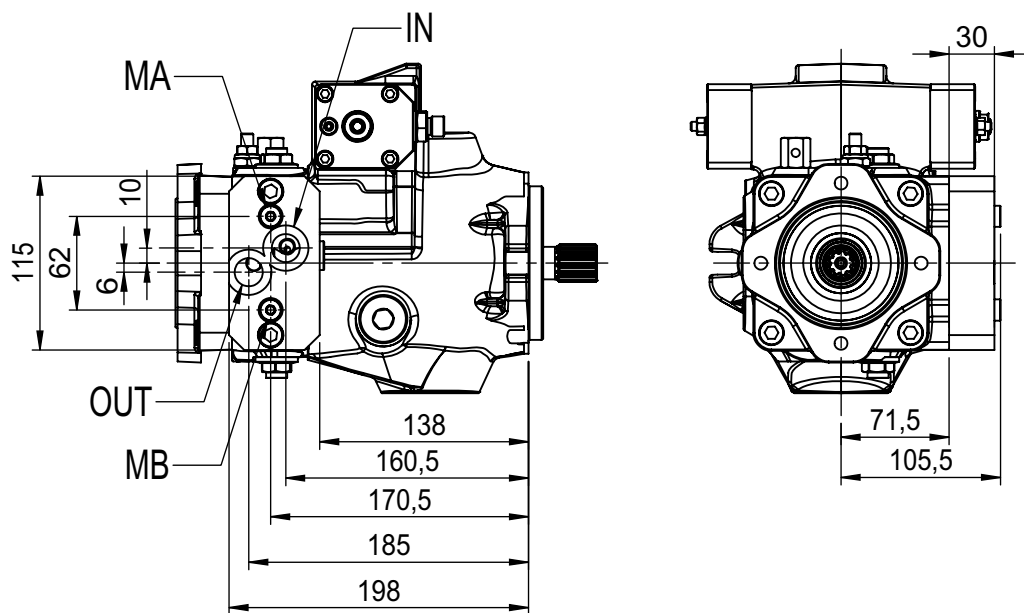

HYDRAULIC DIAGRAM

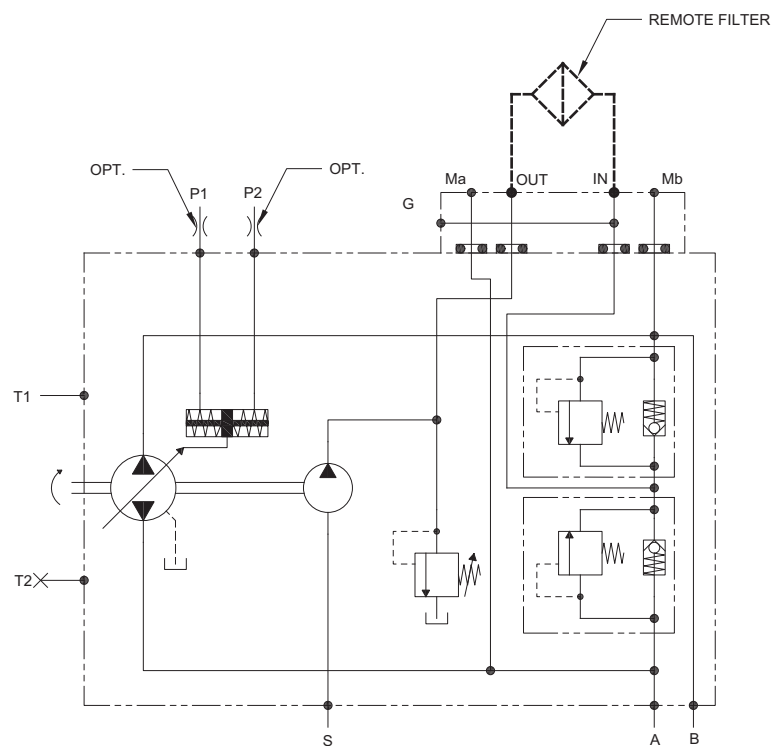

OPTIONAL MOB SHI

MAN ON BOARD

On the pump a normally open electrical operated valve can be fitted. The valve allows the flow delivery only when energized. This function is used to increase the safety of the machine. The solenoid valve is available for 12V or 24V DC voltage.

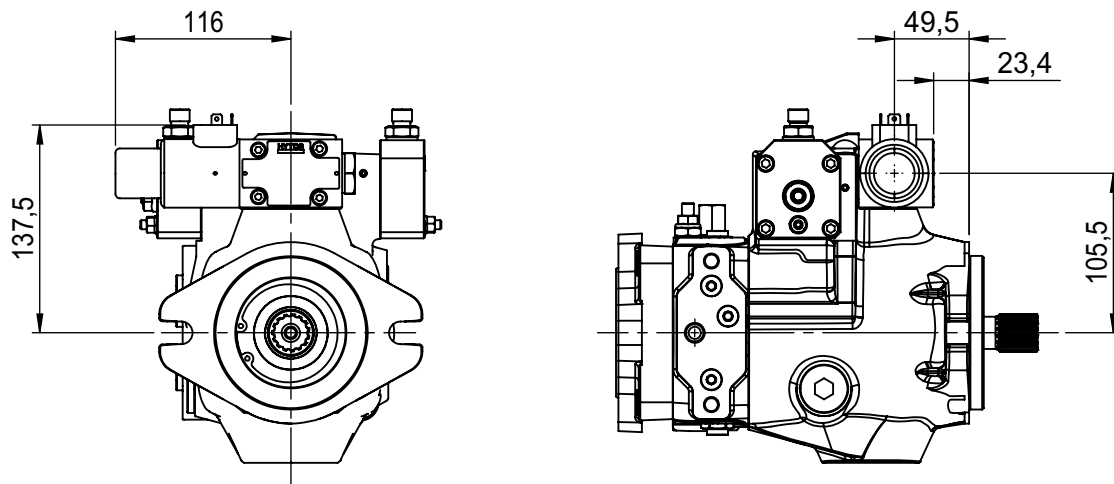

HYDRAULIC DIAGRAM

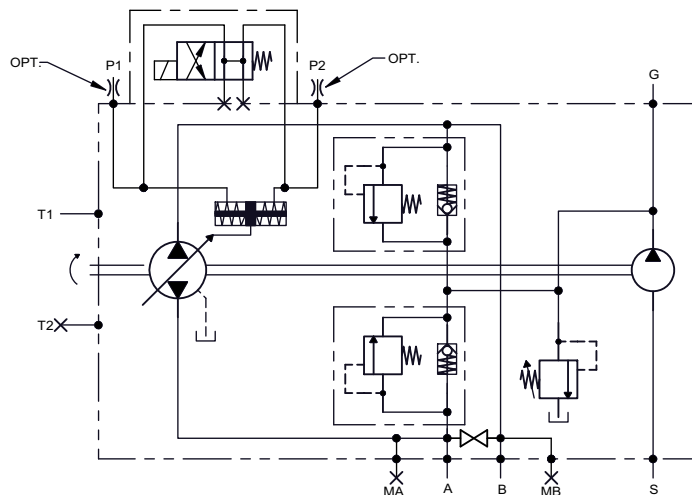

(continued)

OPTIONAL MOB SHI

MAN ON BOARD

TECHNICAL FEATURES

TECHNICAL CHARACTERISTICS	
Maximum pressure	32 MPa
Maximum flow	80 l/min.
Leakage	Max. 5 drops/Min. at 30 MPa
Response time	32 ms
Temperature	-20°C / +90°C

ELECTRIC CHARACTERISTICS	
Voltage	12V / 24V
Insulation class	IP 67
Frequency	1000 Hz
Tolerance of supply	10 - 30 DC
Ambient temperature	-30°C / +50°C
Connector *	EN 17531-803-A

* Other types of connectors are available.

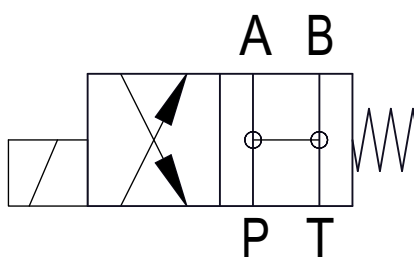

OPTIONAL MOB SEI

MAN ON BOARD

On the pump a normally open electrical operated valve can be fitted. The valve allows the flow delivery only when energized. This function is used to increase the safety of the machine. The solenoid valve is available for 12V or 24V DC voltage.

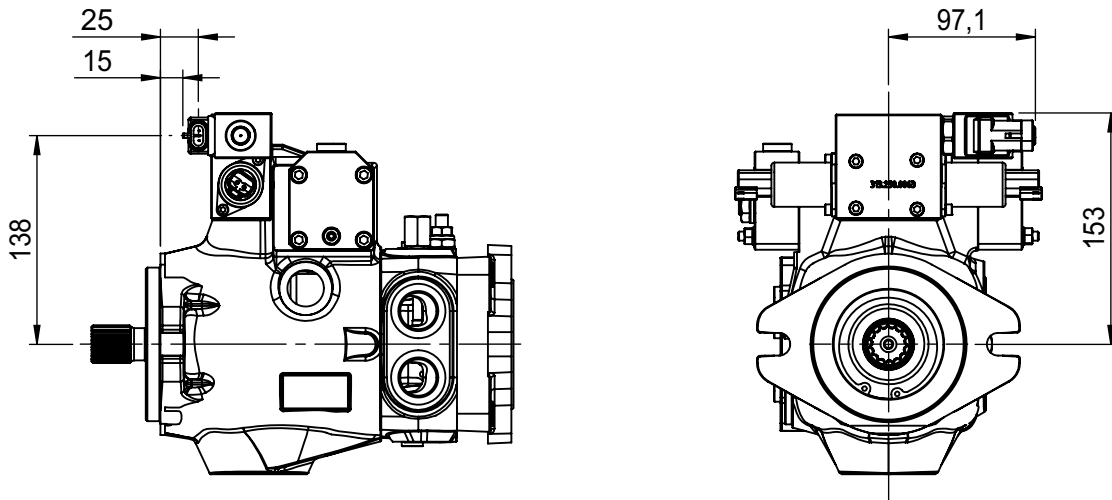

HYDRAULIC DIAGRAM

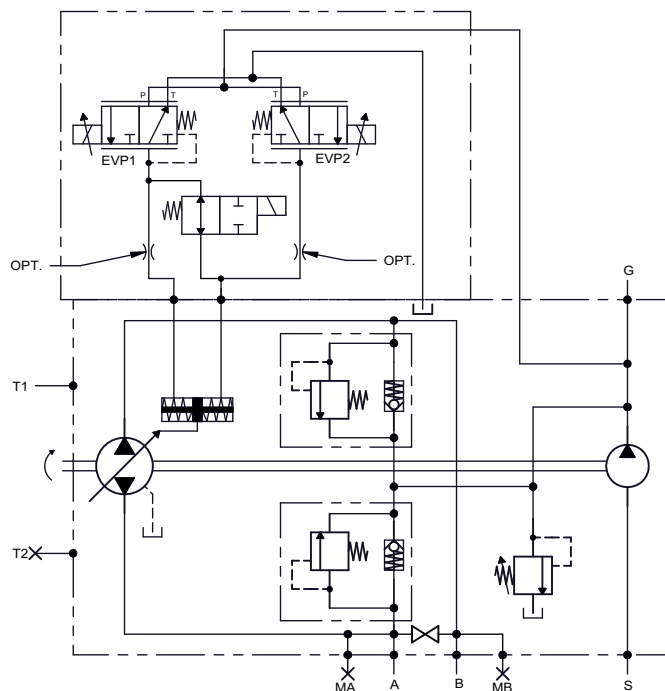

(continued)

OPTIONAL MOB SEI

MAN ON BOARD

TECHNICAL FEATURES

TECHNICAL CHARACTERISTICS	
Maximum pressure	25 MPa
Maximum flow	10 l/min.
Leakage	max. 80 cc/min. at 25 MPa
Response time	30 ms
Temperature	-30°C / +110°C

ELECTRIC CHARACTERISTICS	
Voltage	12V / 24V
Insulation class	F
Power	18W
Tolerance of supply	+10% / -5% AC
Ambient temperature	-30°C / +60°C
Connector *	DIN 43650 Deutsch (90°)

* Other types of connectors are available.

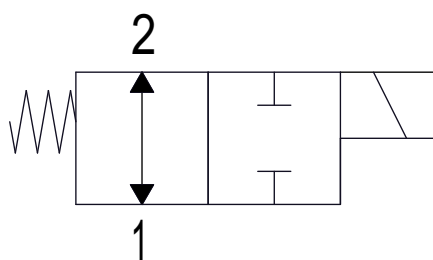

OPTIONAL CO (--)

PRESSURE CUT-OFF VALVE (PRESSURE SETTING)

The CO pressure cut-off valve, when the set pressure is reached, reduces the displacement of the pump in order to maintain a constant working pressure.

The valve operates in place of the pressure relief valves of the pump and increases the energy efficiency of the machine.

The cut-off valve set pressure must be 3 MPa bar lower than the setting of the relief valves.

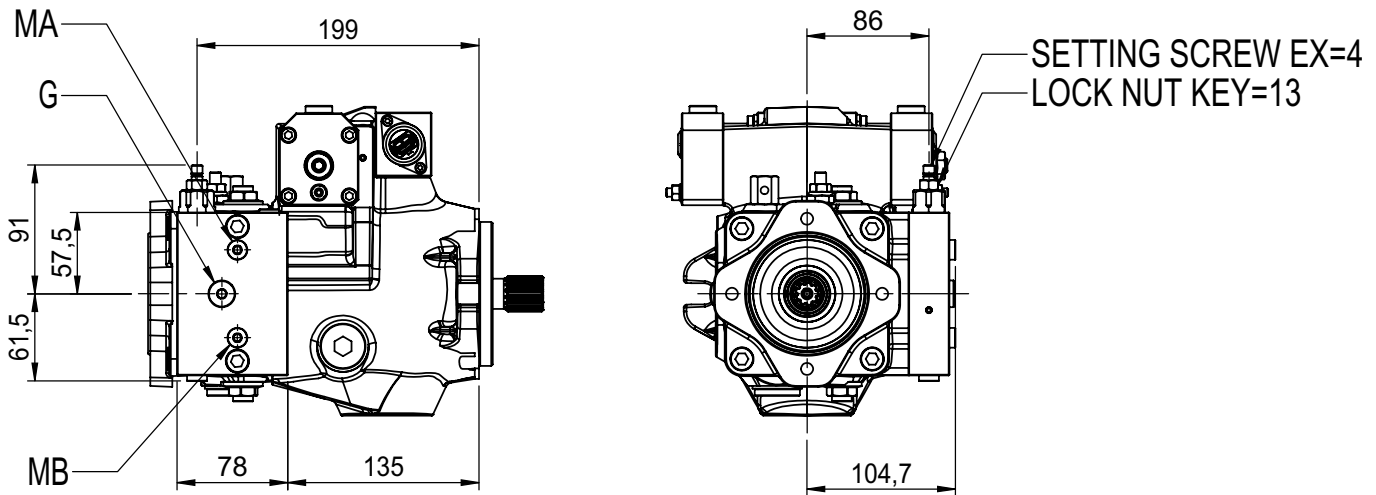

HYDRAULIC DIAGRAM

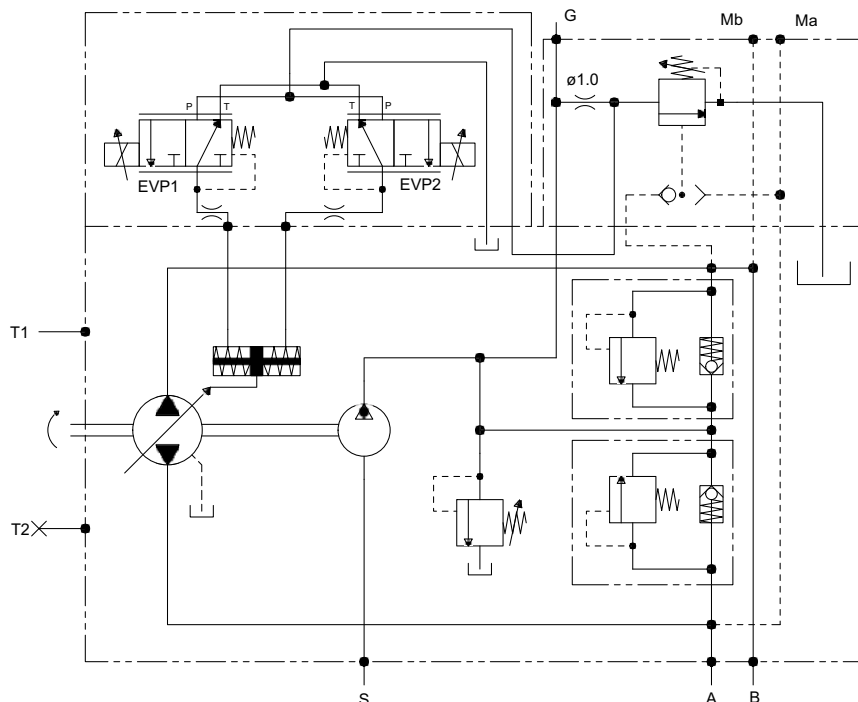

TPVT 4300

VARIABLE DISPLACEMENT AXIAL PISTON TANDEM PUMP

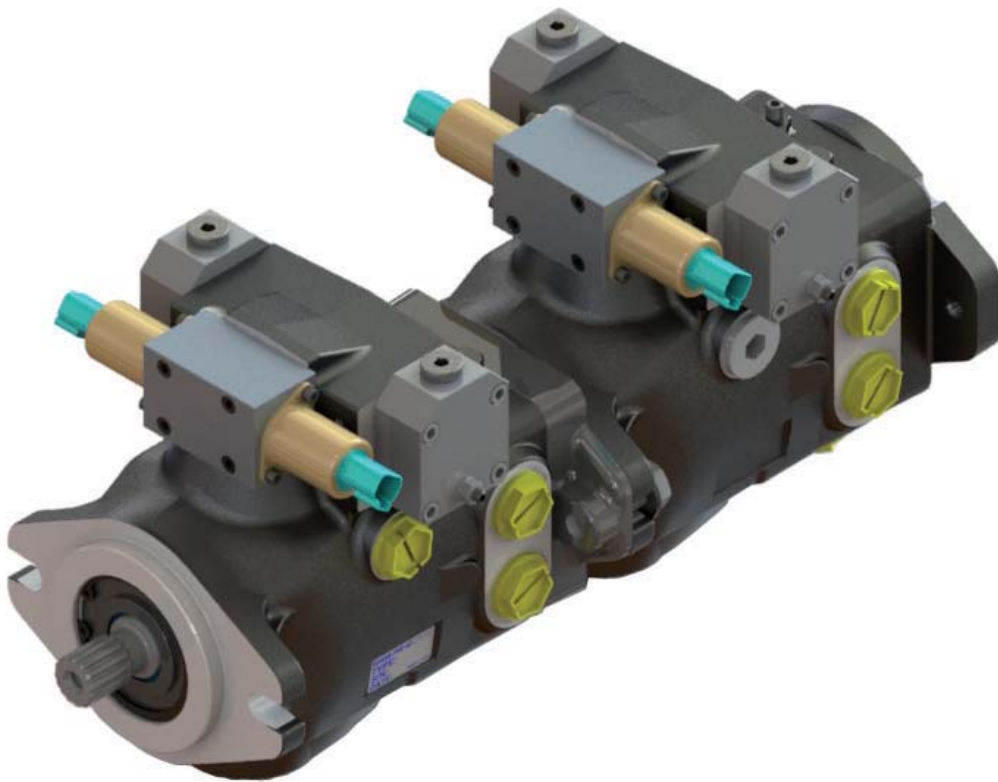

ORDER CODE _____

4300	TPVT	32	32	CR	SS5	F2.2	SHI	SHI	OA	OA	15	15	14	SA	000	SB
0	1	2	3	4	5	6	7	8	9	10	11	12	13	14	15	16

Pag.

4300	0 - Pump series = TPV pump 4300	
TPVT	1 - Pump model = Closed loop circuit tandem pump	
	2 - Pump displacement primary pump 32 = 32 cm ³ /n 38 = 38 cm ³ /n 45 = 45 cm ³ /n 50 = 50 cm ³ /n	
	3 - Pump displacement secondary pump 32 = 32 cm ³ /n 38 = 38 cm ³ /n 45 = 45 cm ³ /n 50 = 50 cm ³ /n	
CR	4 - Pump rotation = Clockwise Rotation (right)	
CC	= Counter-clockwise rotation (left)	
SS3	5 - Shaft (mounting side) = Splined shaft Z13 - 16/32 D.P	17
SS5	= Splined shaft Z15 - 16/32 D.P	17
F2.2	6 - Mounting side flange = SAE-B 2 holes - pilot diam. 101,6 mm.	17
SHI	7 - Control devices position of primary pump = Hydraulic servo control	50
SEI1.3	= Electro-proportional servo control 12V DC (AMP junior timer connector)	52
SEI2.3	= Electro-proportional servo control 24V DC (AMP junior timer connector)	52
SEI1.3D	= Electro-proportional servo control 12V DC (Deutsch connector)	55
SEI2.3D	= Electro-proportional servo control 24V DC (Deutsch connector)	55
SHIX	= Hydraulic servo control with feed back	58
SMIX	= Mechanical lever servo control with feed back	60
SEIX1.2	= Electro-proportional servo control with feed back 12V DC (AMP junior timer connector)	62
SEIX2.2	= Electro-proportional servo control with feed back 24V DC (AMP junior timer connector)	62
SEIX1.2D	= Electro-proportional servo control with feed back 12V DC (Deutsch connector)	65
SEIX2.2D	= Electro-proportional servo control with feed back 24V DC (Deutsch connector)	65
SHI	8 - Control devices position of secondary pump = Hydraulic servo control	50
SEI1.3	= Electro-proportional servo control 12V DC (AMP junior timer connector)	52
SEI2.3	= Electro-proportional servo control 24V DC (AMP junior timer connector)	52
SEI1.3D	= Electro-proportional servo control 12V DC (Deutsch connector)	55
SEI2.3D	= Electro-proportional servo control 24V DC (Deutsch connector)	55
SHIX	= Hydraulic servo control with feed back	58
SMIX	= Mechanical lever servo control with feed back	60
SEIX1.2	= Electro-proportional servo control with feed back 12V DC (AMP junior timer connector)	62
SEIX2.2	= Electro-proportional servo control with feed back 24V DC (AMP junior timer connector)	62
SEIX1.2D	= Electro-proportional servo control with feed back 12V DC (Deutsch connector)	65
SEIX2.2D	= Electro-proportional servo control with feed back 24V DC (Deutsch connector)	65

(continued)

ORDER CODE _____

9 - Control devices position of primary pump

- OA** = Position A
- OB** = Position B (for SEI... versions available on request, please, contact our technical department for details)

10 - Control devices position of secondary pump

- OA** = Position A
- OB** = Position B (for SEI... versions available on request, please, contact our technical department for details)

11 - Primary pump relief valve settings

- | | | |
|--------------------|--------------------|--------------------|
| 15 = 15 MPa | 18 = 18 MPa | 20 = 20 MPa |
| 25 = 25 MPa | 30 = 30 MPa | 35 = 35 MPa |

12 - Secondary pump relief valve settings

- | | | |
|--------------------|--------------------|--------------------|
| 15 = 15 MPa | 18 = 18 MPa | 20 = 20 MPa |
| 25 = 25 MPa | 30 = 30 MPa | 35 = 35 MPa |

13 - Boost pump

- 00** = Without boost pump *
- 14** = Standard boost pump 14 cm³/n - pressure 2 MPa (1000 n/min) for tandem pump
- 14XX** = Boost pump 14 cm³/n - pressure 2 ÷ 3 MPa (1000 n/min) available on request, please contact our technical department for details.

* Upon order, please provide information on maximum external charge flow.

14 - Rear pump connection options

- SA** = SAE-A 4 holes mounting flange (female shaft) **68**
- SB** = SAE-B 2 holes mounting flange (female shaft) **68**
- C-SA** = Closed (without rear fitting) **69**

15 - Auxiliary gear pump displacements

- 000** = Without pump

Group 2 SAE-A

- | | | | |
|--------------------------------------|--------------------------------------|--------------------------------------|--------------------------------------|
| 204 = 4,2 cm ³ /n | 206 = 6,0 cm ³ /n | 209 = 8,4 cm ³ /n | 211 = 10,8 cm ³ /n |
| 214 = 14,4 cm ³ /n | 217 = 16,8 cm ³ /n | 219 = 19,2 cm ³ /n | 222 = 22,8 cm ³ /n |
| 226 = 26,2 cm ³ /n | 230 = 30,0 cm ³ /n | 240 = 40,0 cm ³ /n | |

Group 3 SAE-B

- | | | | |
|--------------------------------------|--------------------------------------|--------------------------------------|--------------------------------------|
| 315 = 15,0 cm ³ /n | 318 = 18,0 cm ³ /n | 321 = 21 cm ³ /n | 327 = 27,0 cm ³ /n |
| 332 = 32,0 cm ³ /n | 338 = 38,0 cm ³ /n | 343 = 43,0 cm ³ /n | 347 = 47,0 cm ³ /n |
| 351 = 51,0 cm ³ /n | 354 = 54,0 cm ³ /n | 361 = 61,0 cm ³ /n | 364 = 64,0 cm ³ /n |
| 370 = 70,0 cm ³ /n | 374 = 74,0 cm ³ /n | 390 = 90,0 cm ³ /n | |

(continued)

ORDER CODE _____

- 16 - Optional**
- 00** = Without optional
 - SB** = Screw by-pass (Standard) **70**
 - FR** = Pre-arranged for connection with external filter **71**
 - MOB (SHI)** = Man on board with SHI Hydraulic servo control **72**
 - MOB (SEI)** = Man on board with SEI Electro-proportional servo control **74**
 - G/J/M/-** = Port threads and restrictor diameter

	Servo control type	Port threads	Symbol
STANDARD	SEI	Plugged	-
	SHI	1/4" BSPP	G
ON REQUEST	SHI	JIC (7/16" - 20)	J
	SHI	METRIC (M12x1,5)	M

Restrictor diameter (SHI/SEI)	
-	Without restrictor
06	Restrictor orifice ø 0,6 mm
08	Restrictor orifice ø 0,8 mm
10	Restrictor orifice ø 1,0 mm
12	Restrictor orifice ø 1,2 mm
16	Restrictor orifice ø 1,6 mm
20	Restrictor orifice ø 2,0 mm

Example G/08 = 1/4" BSPP port threads and Ø 0,8 mm restrictor (SHI)

Example -/08 = Ø 0,8 mm restrictor (SEI)

GENERAL DIMENSIONS/TANDEM PUMP PORTS

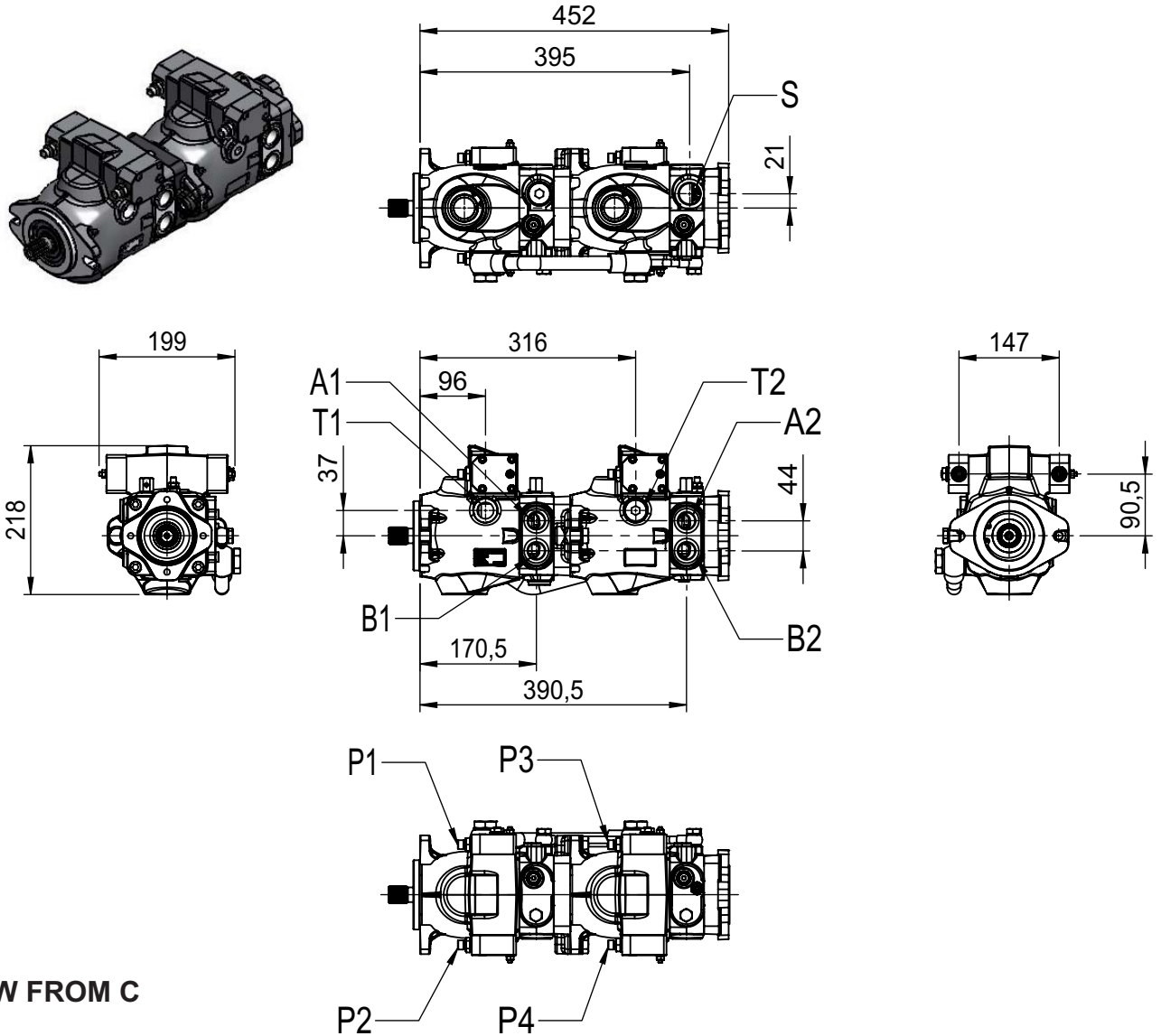

VIEW FROM C

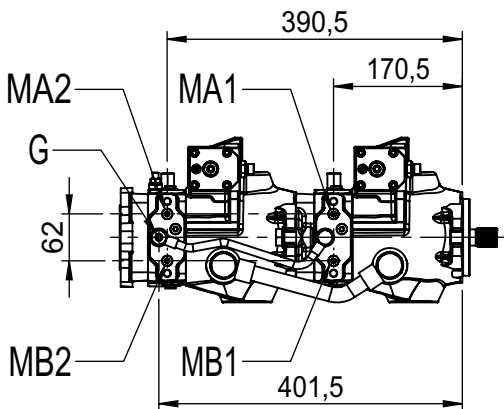

PORTS		
A1 - B1	Main pressure ports 1	3/4" BSPP
A2 - B2	Main pressure ports 2	3/4" BSPP
T1 - T2	Drain	3/4" BSPP
S	Suction	1" BSPP
G1 - G2	Boost pumps pressure gauge ports	1/8" BSPP
MA1 - MB1 MA2 - MB2	Pressure gauge ports	1/8" BSPP
P1 - P2 P3 - P4	Pilot pressure	1/4" BSPP



SHI

HYDRAULIC SERVO CONTROL

The pump displacement variation is obtained by adjusting the pressure on P1, P2, P3 and P4 servo control ports by means of a hydraulic proportional joystick (with integrated pressure reducing valves).

The servo control oil supply can be obtained by taking pressure from the boost pump (G1 - G2 ports), see pag. 49.

The servo control return time can be adjusted

by inserting a restrictor on the joystick supply line (0,5 ÷ 1,2 mm).

The servo control operation curve, in both directions, goes from 0,4 to 1,8 MPa (tolerance $\pm 5\%$).

The adjusting curve of the hydraulic joystick has to be a little wider (0,3 ÷ 1,9 MPa).

Suggested curves for HPV series Joysticks: CR062 (see HT 73/B/105/0417/E catalogue).

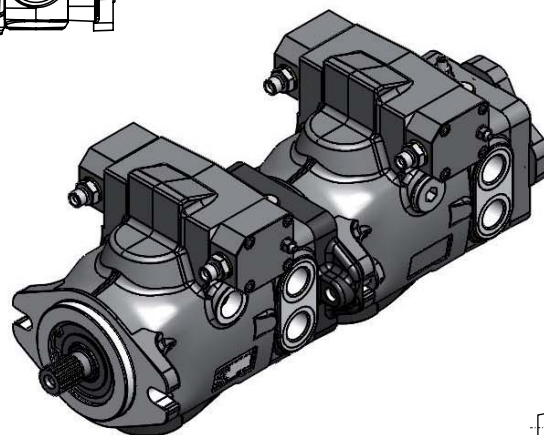
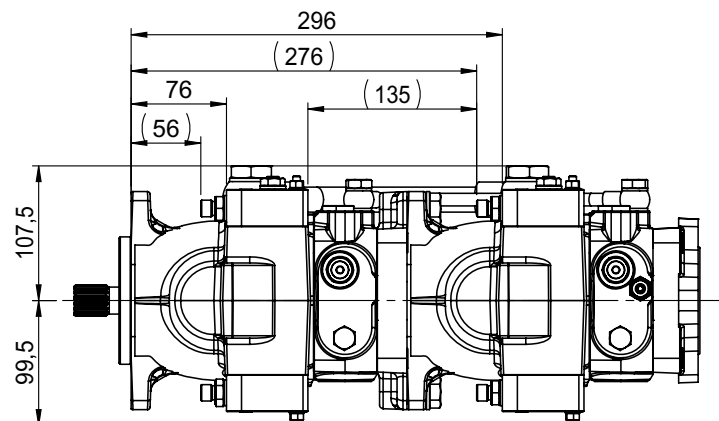
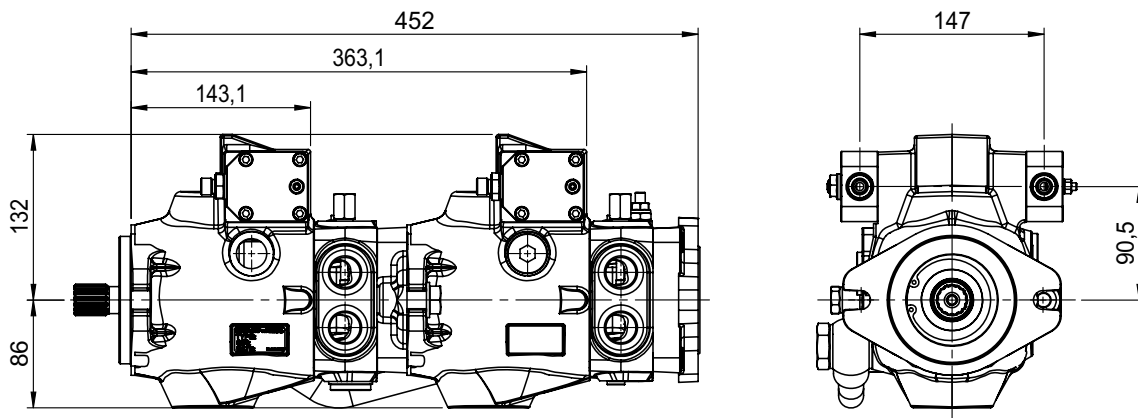

(continued)

SHI

HYDRAULIC SERVO CONTROL

HYDRAULIC DIAGRAM

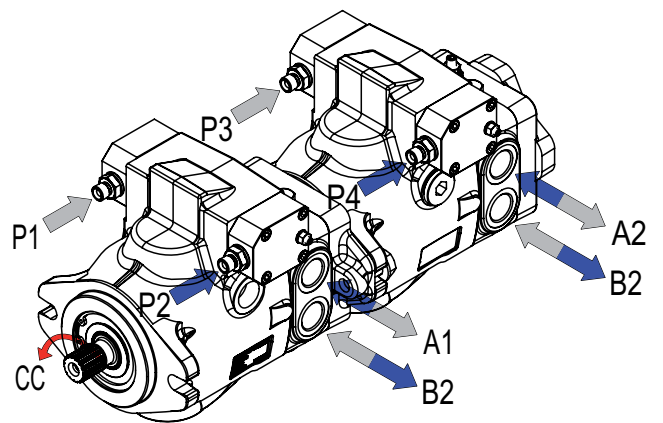
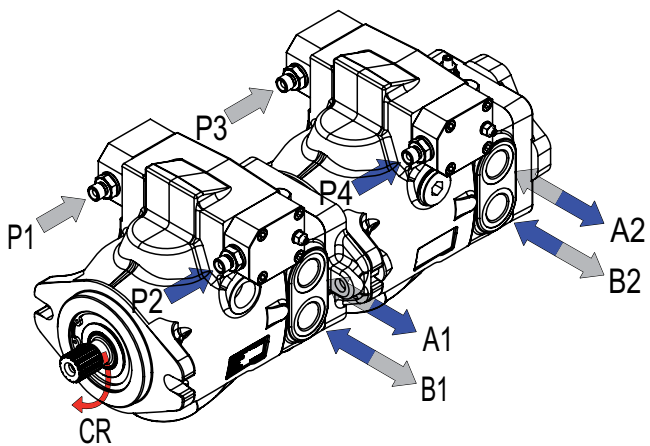
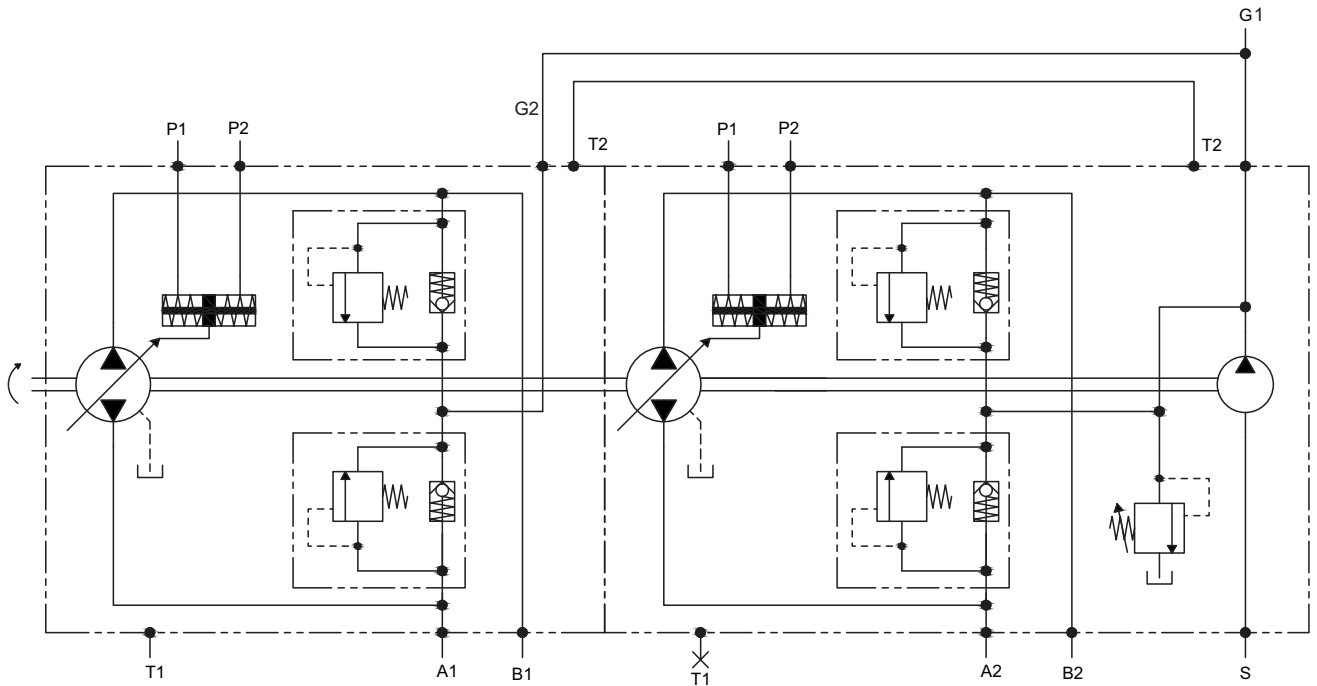

SEI 1.3 (12V DC)

SEI 2.3 (24V DC)

ELECTRO-PROPORTIONAL SERVO CONTROL

(AMP junior timer connector)

The pump displacement variation is obtained by an electric signal, which varies approx.:

- from 315 to 630 mA (24V DC voltage)
- from 630 to 1260 mA (12V DC voltage)

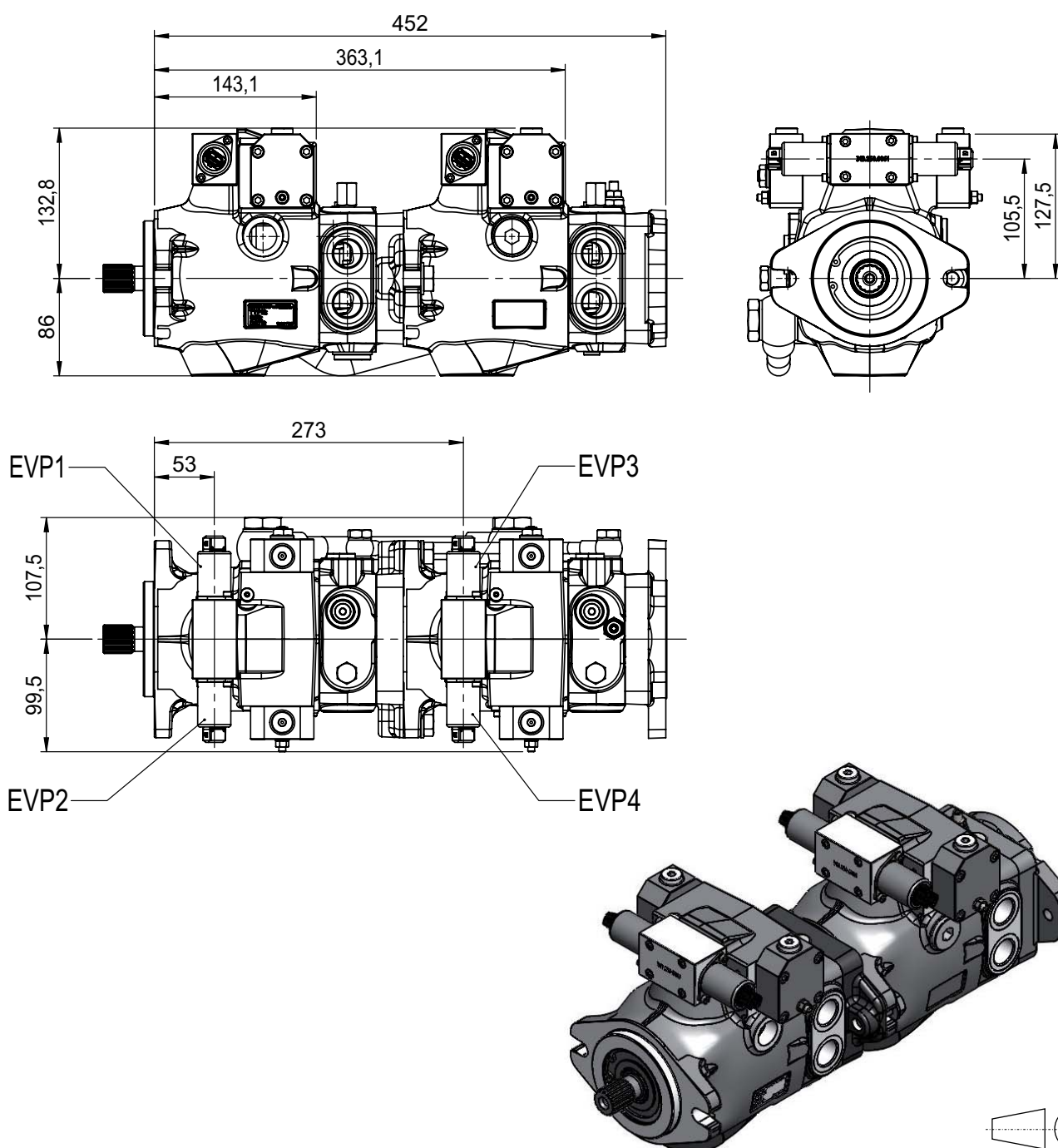

(continued)

SEI 1.3 (12V DC)

SEI 2.3 (24V DC)

ELECTRO-PROPORTIONAL SERVO CONTROL

(AMP junior timer connector)

HYDRAULIC DIAGRAM

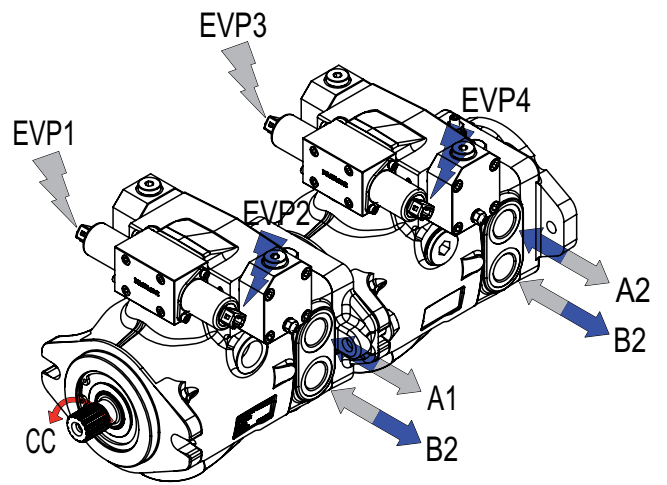
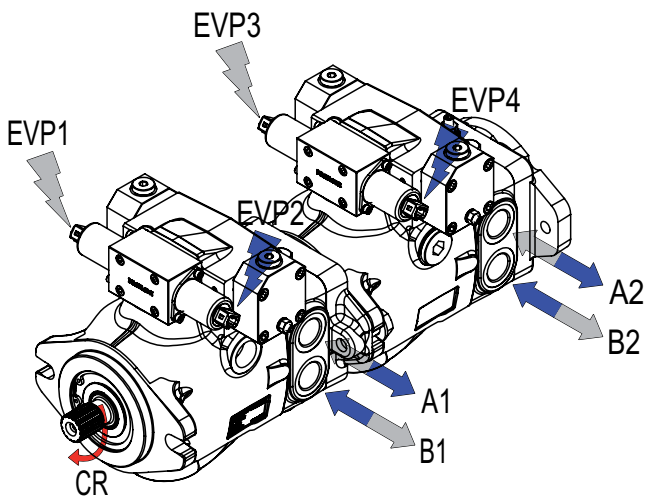
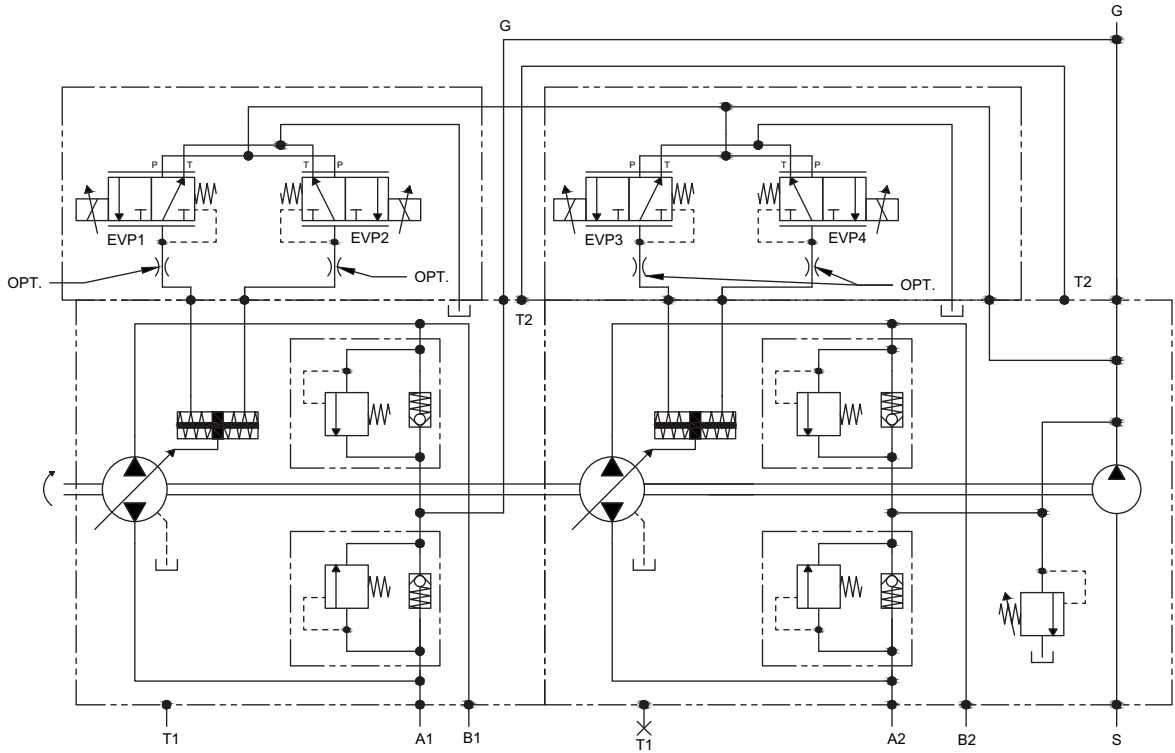

(continued)

SEI 1.3 (12V DC)

SEI 2.3 (24V DC)

ELECTRO-PROPORTIONAL SERVO CONTROL

(AMP junior timer connector)

CURRENT-DISPLACEMENT GRAPHIC

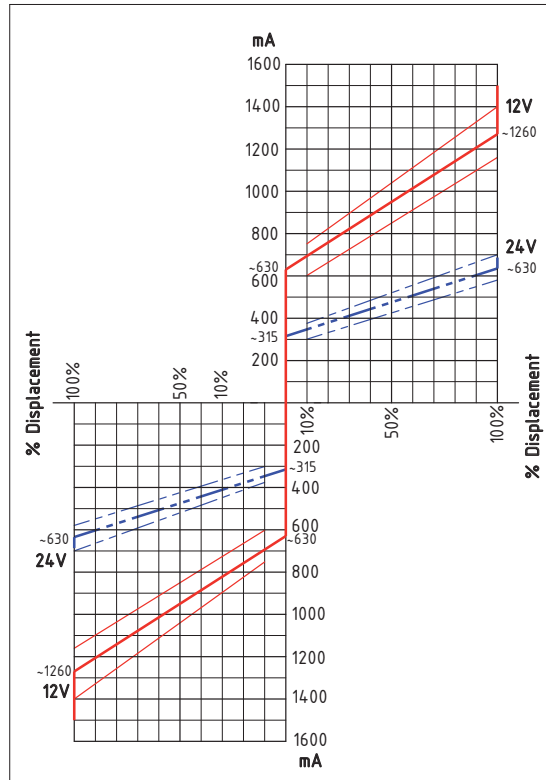

SOLENOID VALVE ELECTRICAL FEATURES		
Voltage	12 V DC	24 V DC
Electric current	1500 mA	750 mA
Load resistance	4,72 Ω ± 5%	20,8 Ω ± 5%
Type of control	Current control PWM 100 Hz (suggested)	
Type of connection	AMP Junior Timer	
Protection class	Until IP6K6 / IPX9K	

SOLENOID VALVE HYDRAULIC FEATURES	
Max. pressure (P, T)	pP= 5 MPa, pT= 3 MPa
Hysteresis (w/PWM)	<0,07 MPa (pA=2,0)
	<0,1 MPa (pA=2,5)
	<0,15 MPa (pA=3,5)
Filtration ratio	125 μm
Oil contamination level	Min. filtration ratio: 20/18/15
	According ISO 4406
	Hydraulic oil DIN 51524
Min./max. oil temperature	From -20 to +90°C

SEI 1.3D (12V DC)

SEI 2.3D (24V DC)

ELECTRO-PROPORTIONAL SERVO CONTROL

(Deutsch connector)

The pump displacement variation is obtained by an electric signal, which varies approx.:

- from 315 to 630 mA (24V DC voltage)
- from 630 to 1260 mA (12V DC voltage)

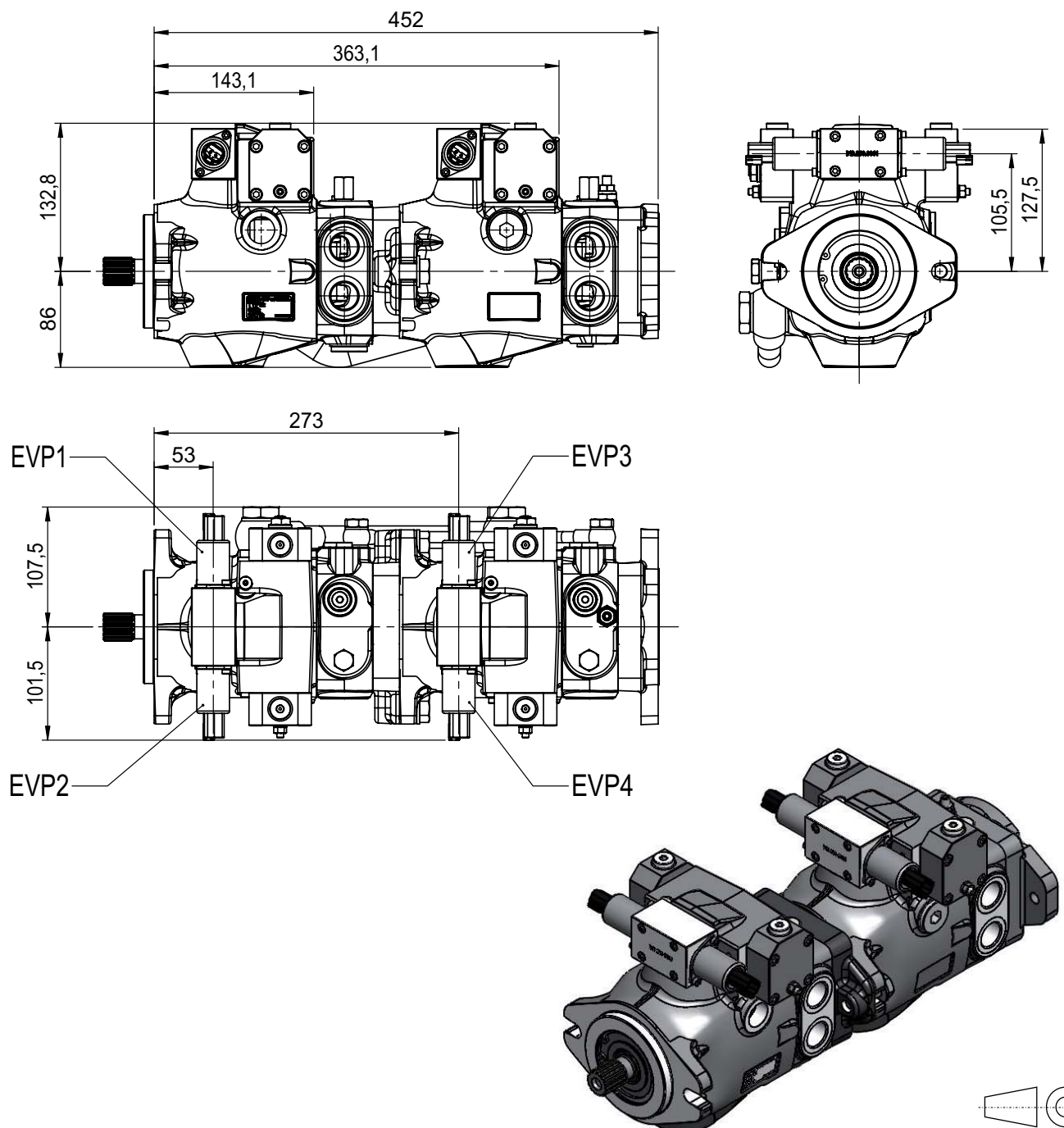

(continued)

SEI 1.3D (12V DC)

SEI 2.3D (24V DC)

ELECTRO-PROPORTIONAL SERVO CONTROL

(Deutsch connector)

HYDRAULIC DIAGRAM

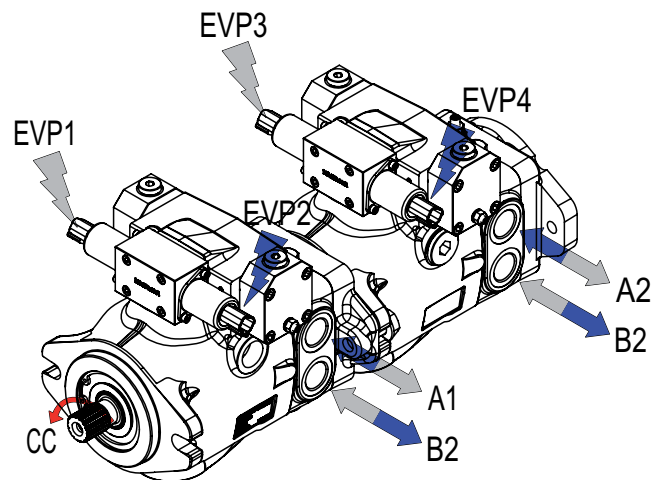
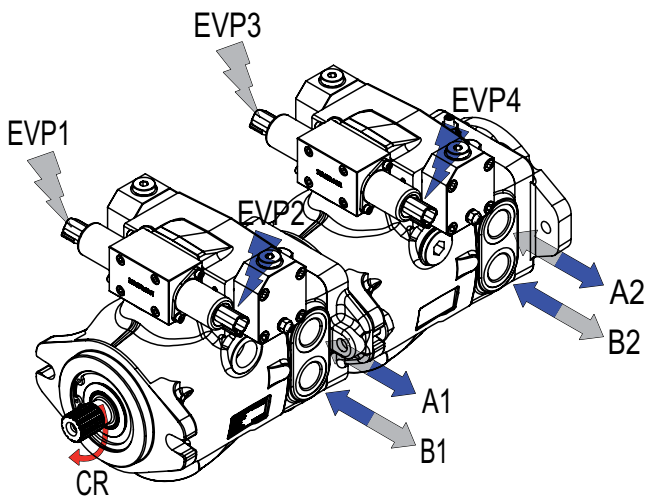
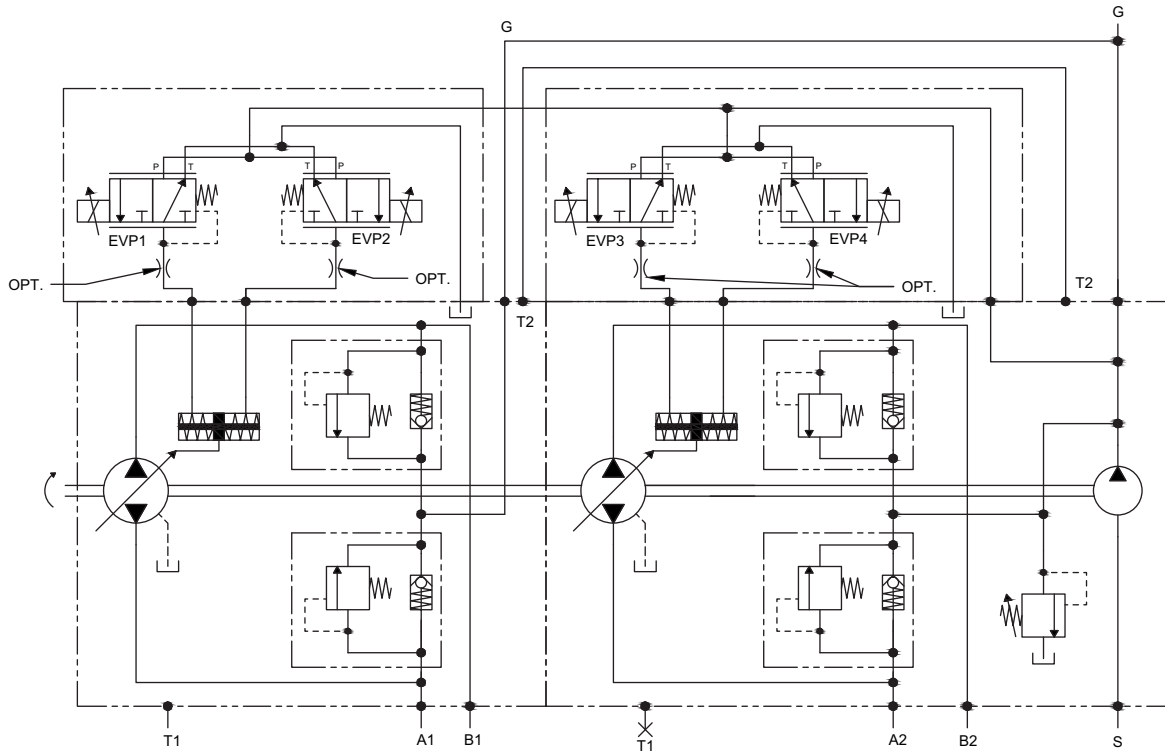

(continued)

SEI 1.3D (12V DC)

SEI 2.3D (24V DC)

ELECTRO-PROPORTIONAL SERVO CONTROL

(Deutsch connector)

CURRENT-DISPLACEMENT GRAPHIC

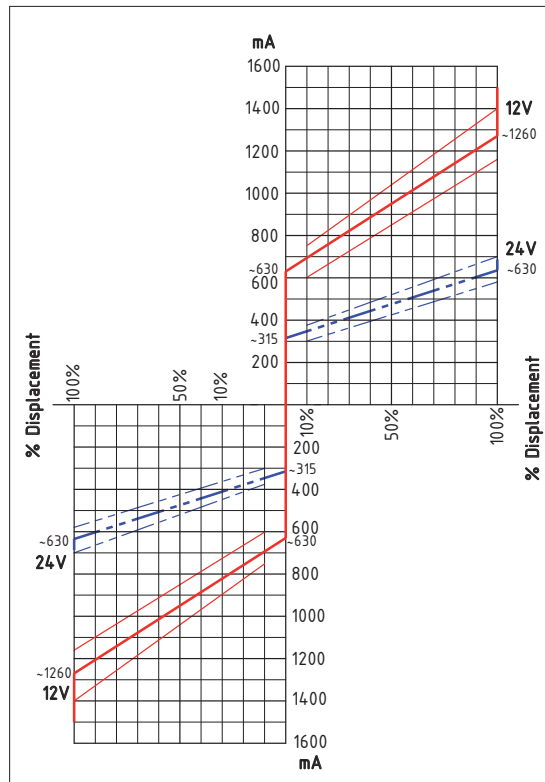

SOLENOID VALVE ELECTRICAL FEATURES		
Voltage	12 V DC	24 V DC
Electric current	1500 mA	750 mA
Load resistance	4,72 Ω ± 5%	20,8 Ω ± 5%
Type of control	Current control	
	PWM 100 Hz (suggested)	
Type of connection	DEUTSCH DT 04-2P	
Protection class	Until IP6K6 / IPX9K	

SOLENOID VALVE HYDRAULIC FEATURES	
Max. pressure (P, T)	pP= 5 MPa, pT= 3 MPa
Hysteresis (w/PWM)	<0,07 MPa (pA=2,0)
	<0,1 MPa (pA=2,5)
	<0,15 MPa (pA=3,5)
Filtration ratio	125 µm
Oil contamination level	Min. filtration ratio: 20/18/15
	According ISO 4406
	Hydraulic oil DIN 51524
Min./max. oil temperature	From -20 to +90°C

SHIX

HYDRAULIC SERVO CONTROL WITH FEED BACK

The pump displacement variation is obtained by adjusting the pressure on P1 and P2 servo control ports by means of a hydraulic proportional joystick (with integrated pressure reducing valves).

The servo control oil supply can be obtained by taking pressure from the boost pump (G port), see page 49.

The servo control return time can be adjusted by inserting a restrictor on the joystick supply line (0,5 ÷ 1,2 mm).

The servo control operation curve, in both directions, goes from 0,4 to 2 MPa (tolerance $\pm 5\%$).

The adjusting curve of the hydraulic joystick has to be a little wider (0,3 ÷ 2,1 MPa).

Suggested curves for HPV series Joysticks: CR096 (see HT 73/B/105/0417/E catalogue).

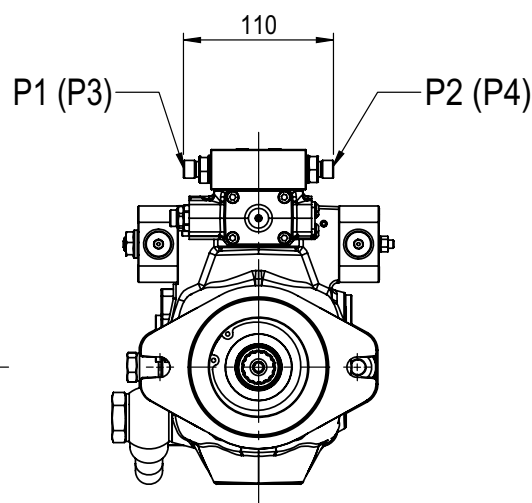
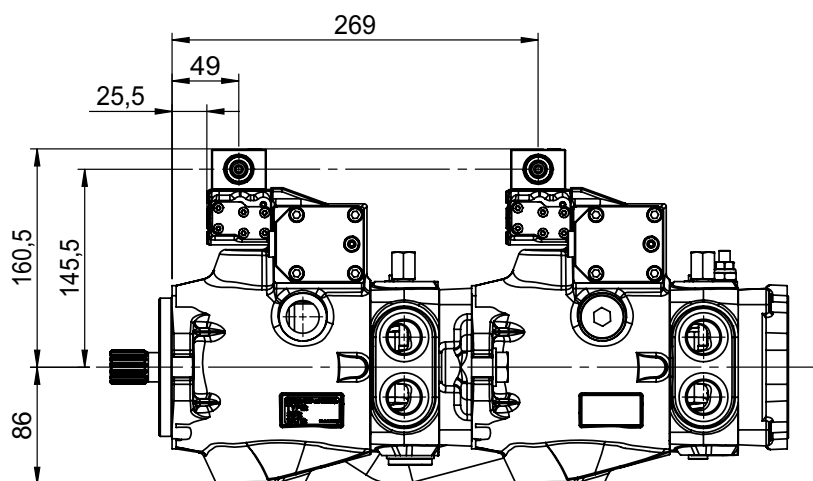

(continued)

SHIX

HYDRAULIC SERVO CONTROL WITH FEED BACK

HYDRAULIC DIAGRAM

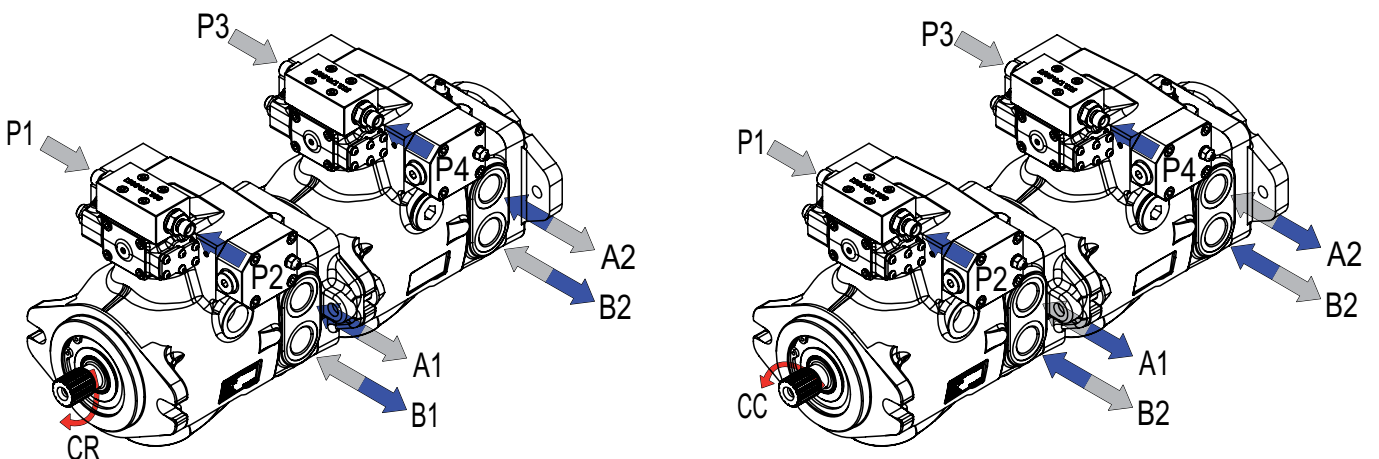
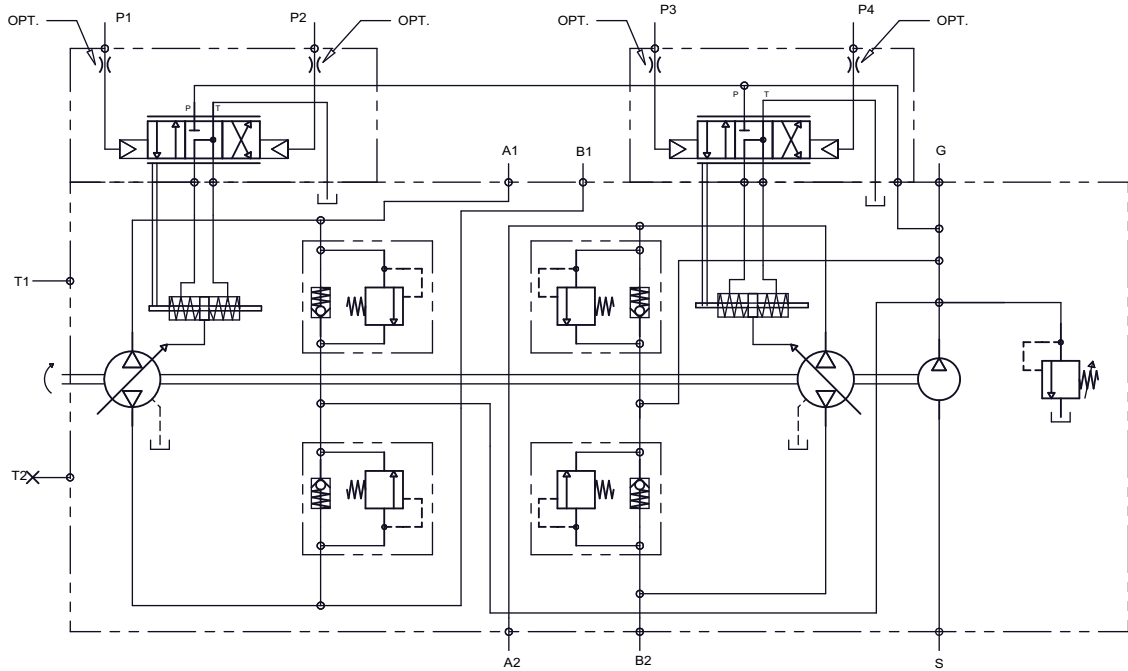

SMIX

MANUAL LEVER CONTROL WITH FEED BACK

The pump displacement variation is directly related to the angle position of the lever.

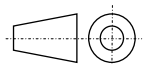
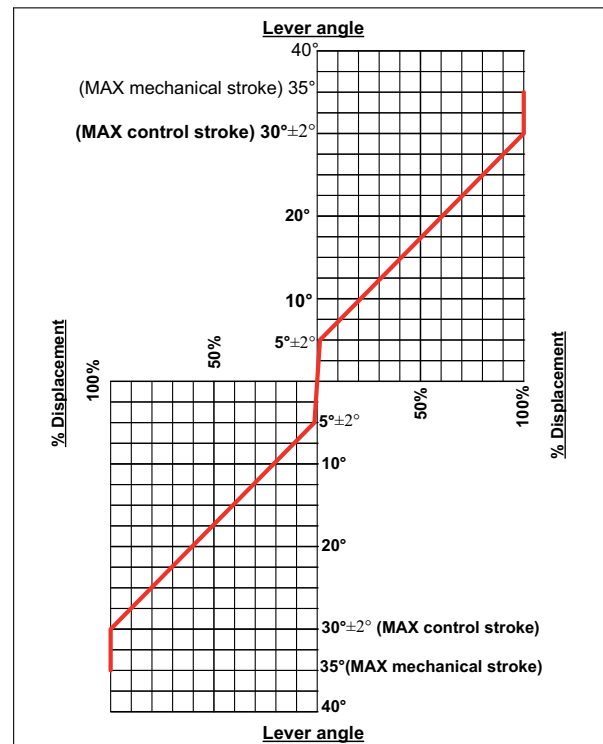
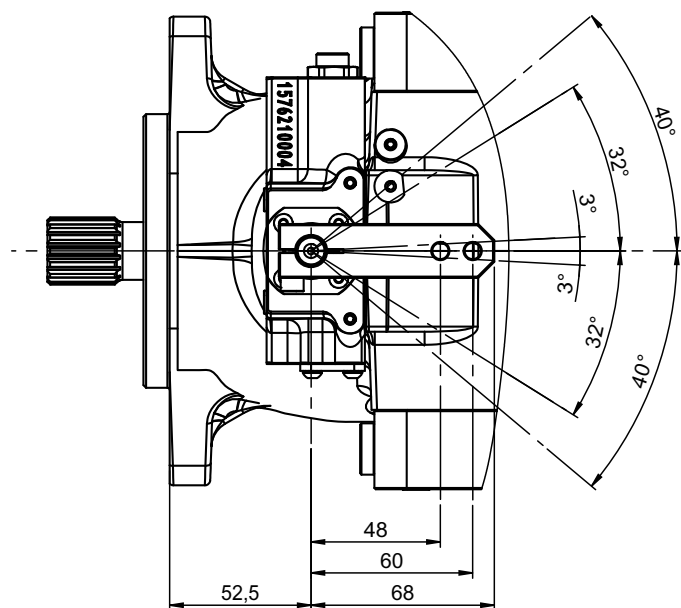
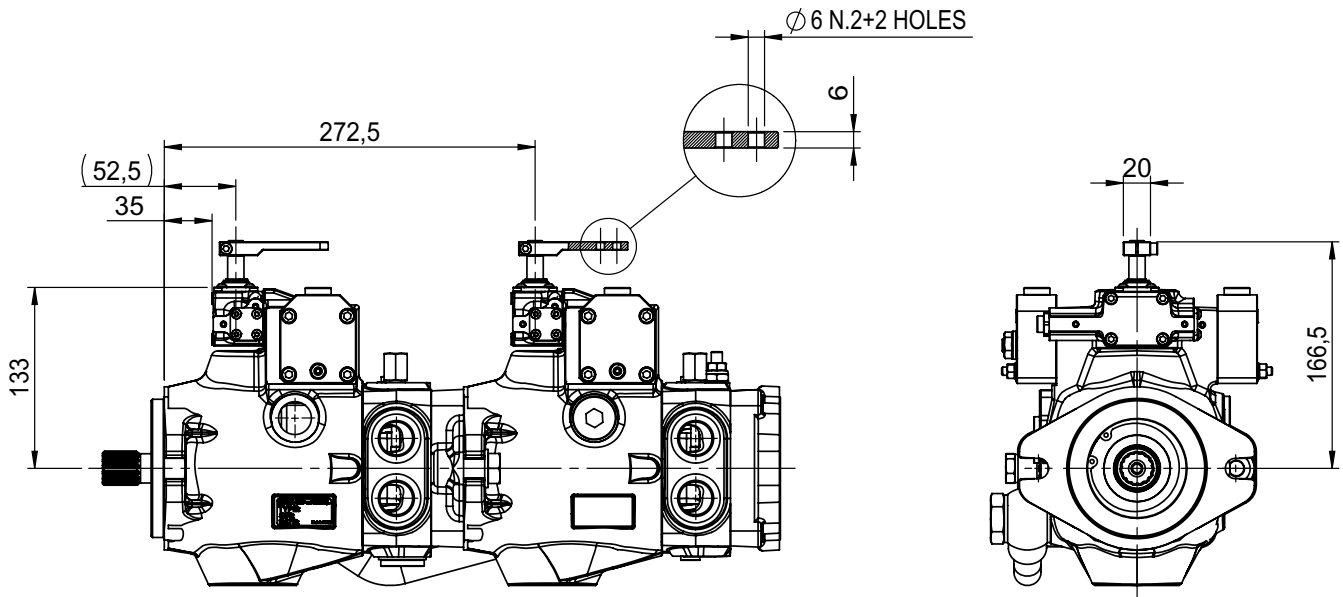

(continued)

SMIX

MANUAL LEVER CONTROL WITH FEED BACK

HYDRAULIC DIAGRAM

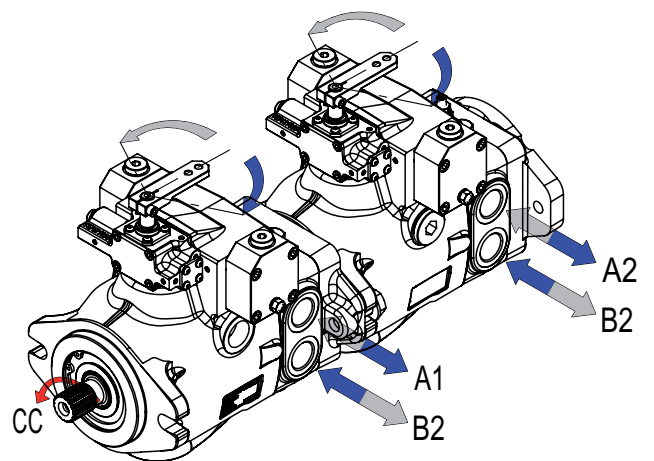
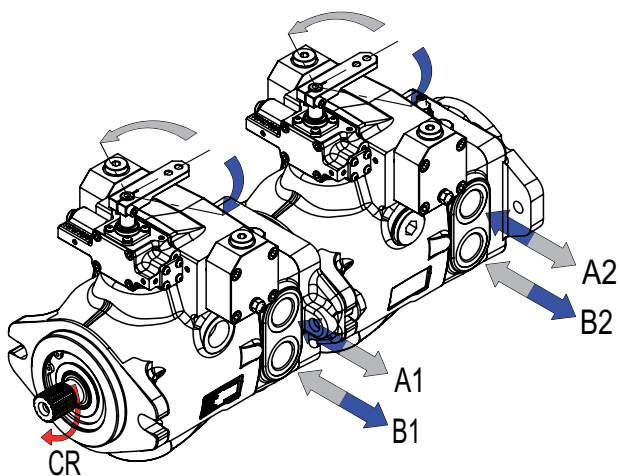
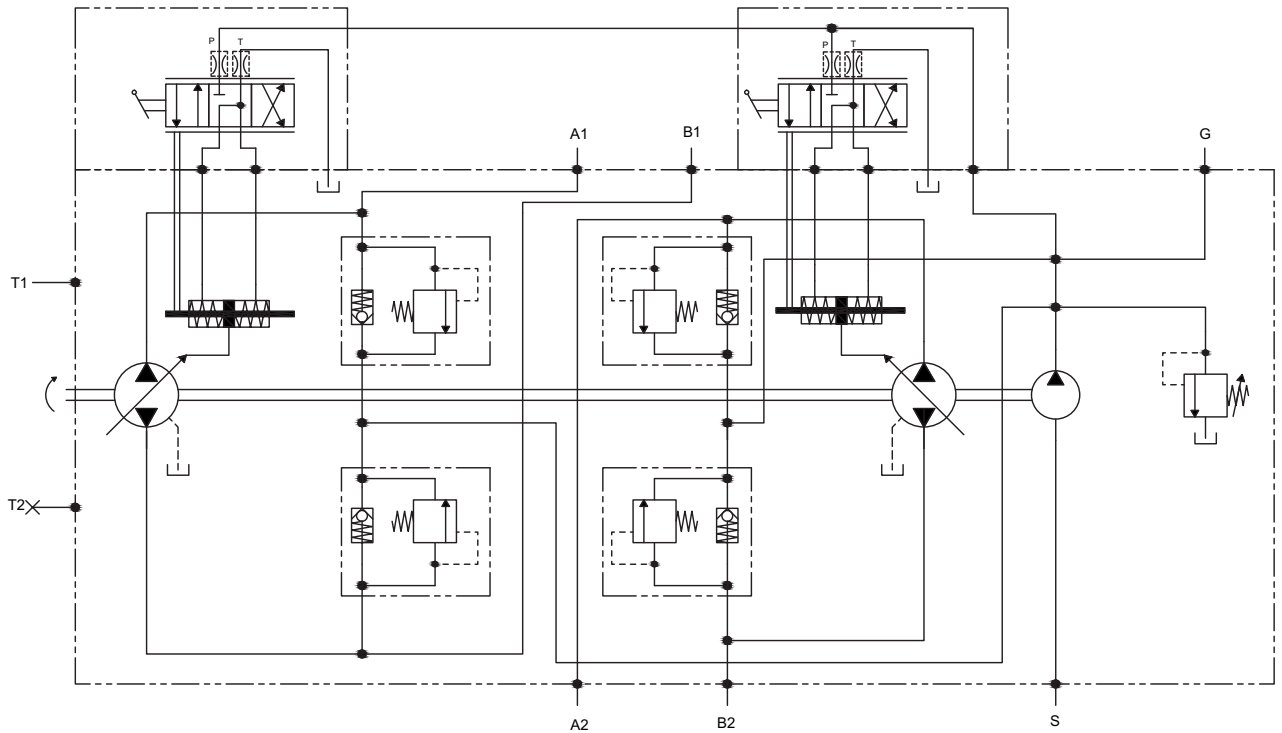

SEIX 1.2 (12V DC)

SEIX 2.2 (24V DC)

ELECTRO-PROPORTIONAL SERVO CONTROL WITH FEED BACK

(AMP junior timer connector)

The pump displacement variation is obtained by an electric signal, which varies approx.:

- from 315 to 630 mA (24V DC voltage)
- from 630 to 1260 mA (12V DC voltage)

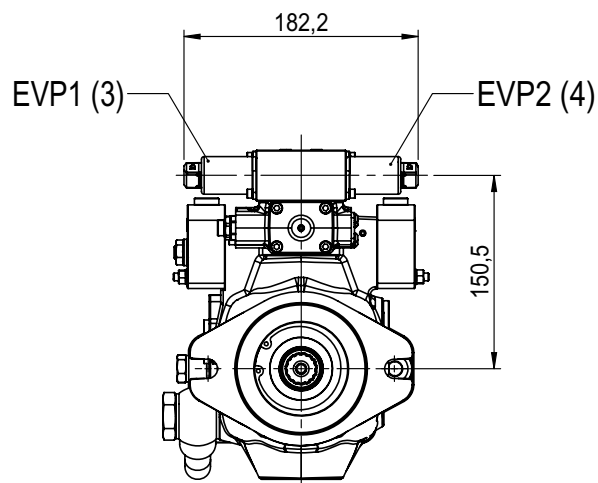
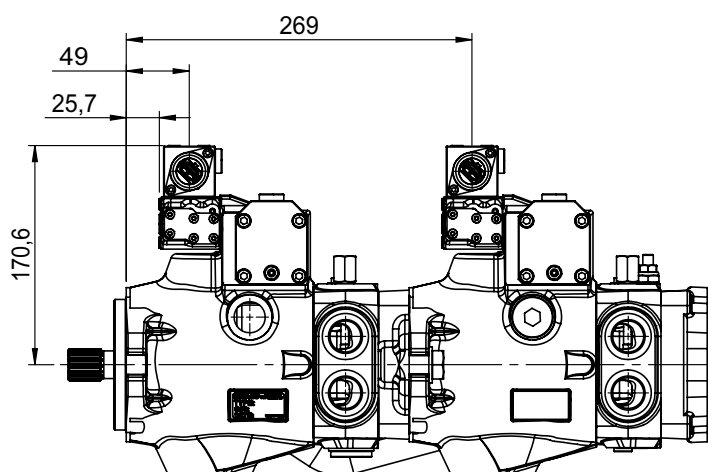

(continued)

SEIX 1.2 (12V DC)
SEIX 2.2 (24V DC)

ELECTRO-PROPORTIONAL SERVO CONTROL WITH FEED BACK

(AMP junior timer connector)

HYDRAULIC DIAGRAM

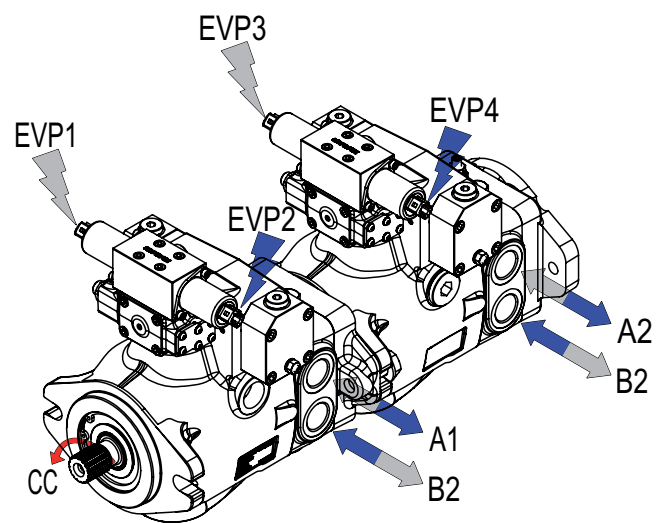
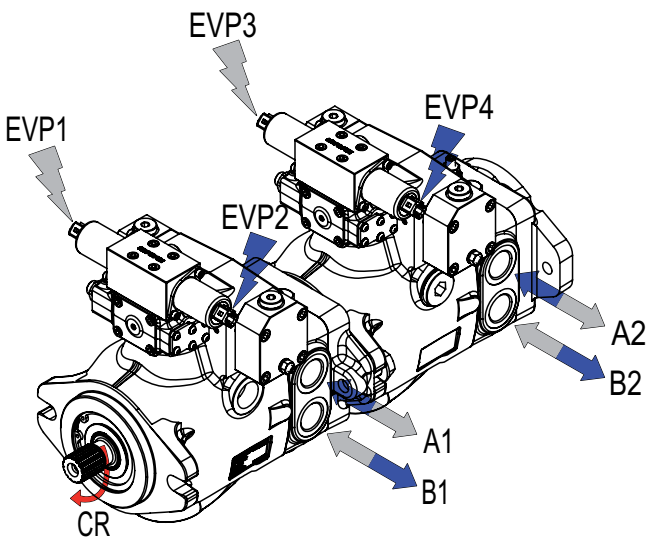
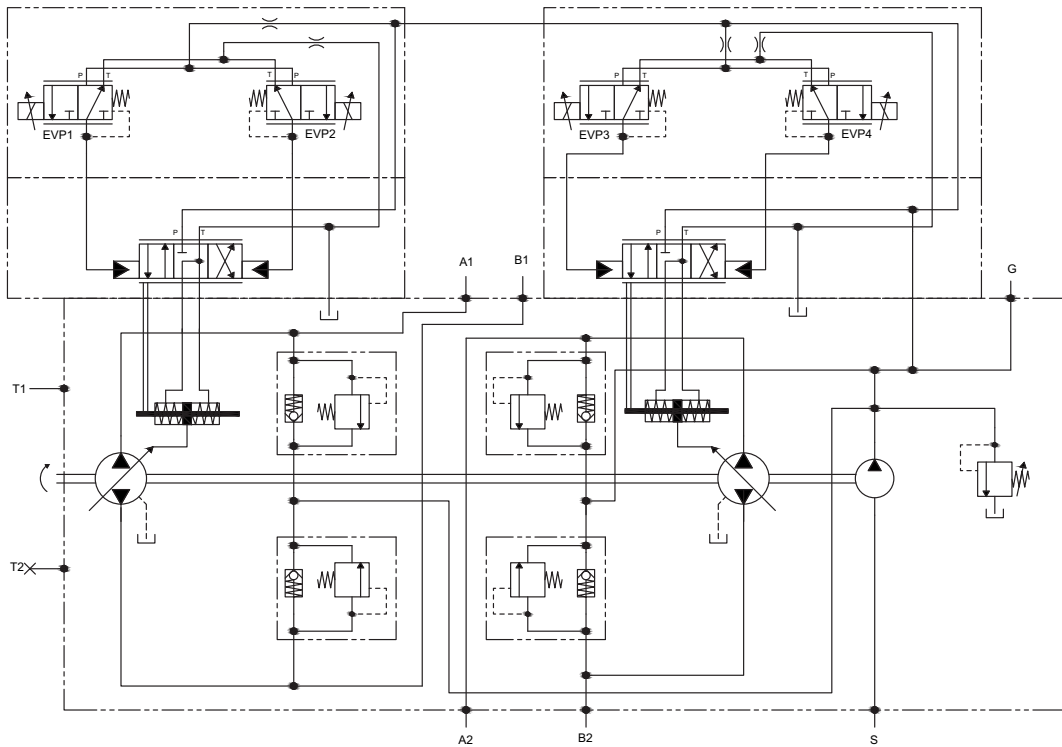

(continued)

SEIX 1.2 (12V DC)

SEIX 2.2 (24V DC)

ELECTRO-PROPORTIONAL SERVO CONTROL WITH FEED BACK

(AMP junior timer connector)

CURRENT-DISPLACEMENT GRAPHIC

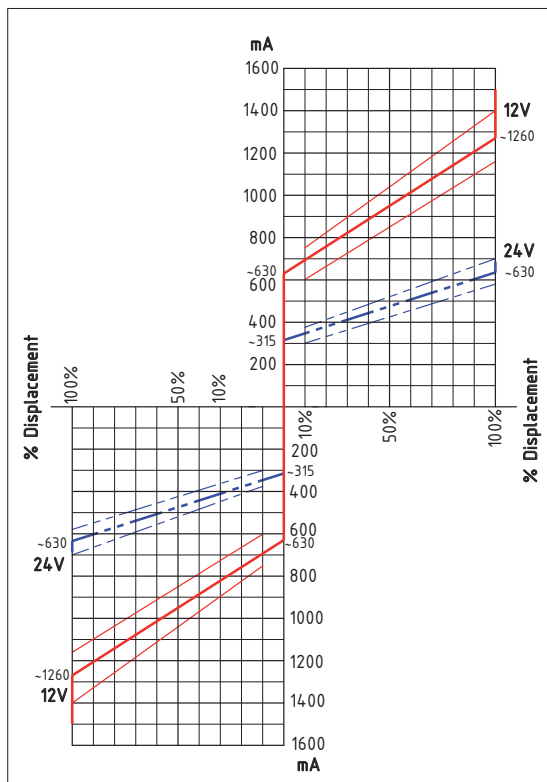

SOLENOID VALVE ELECTRICAL FEATURES		
Voltage	12 V DC	24 V DC
Electric current	1500 mA	750 mA
Load resistance	4,72 Ω ± 5%	20,8 Ω ± 5%
Type of control	Current control PWM 100 Hz (suggested)	
Type of connection	AMP Junior Timer	
Protection class	Until IP6K6 / IPX9K	

SOLENOID VALVE HYDRAULIC FEATURES	
Max. pressure (P, T)	pP= 5 MPa, pT= 3 MPa
Hysteresis (w/PWM)	<0,07 MPa (pA=2,0)
	<0,1 MPa (pA=2,5)
	<0,15 MPa (pA=3,5)
Filtration ratio	125 μm
Oil contamination level	Min. filtration ratio: 20/18/15
	According ISO 4406
	Hydraulic oil DIN 51524
Min./max. oil temperature	From -20 to +90°C

SEIX 1.2D (12V DC)
SEIX 2.2D (24V DC)

ELECTRO-PROPORTIONAL SERVO CONTROL WITH FEED BACK

(Deutsch connector)

The pump displacement variation is obtained by an electric signal, which varies approx.:

- from 315 to 630 mA (24V DC voltage)
- from 630 to 1260 mA (12V DC voltage)

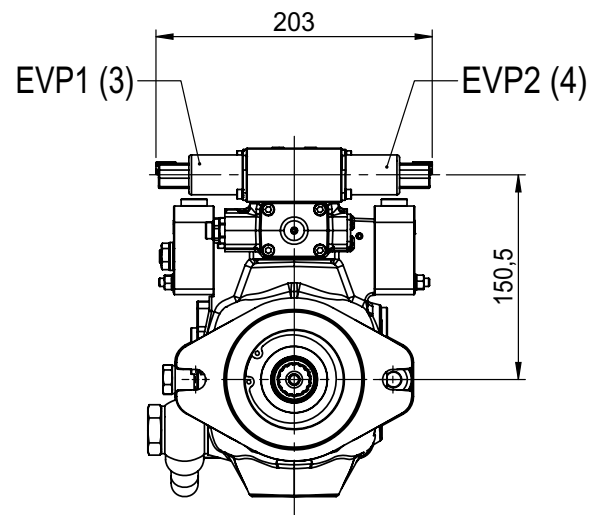
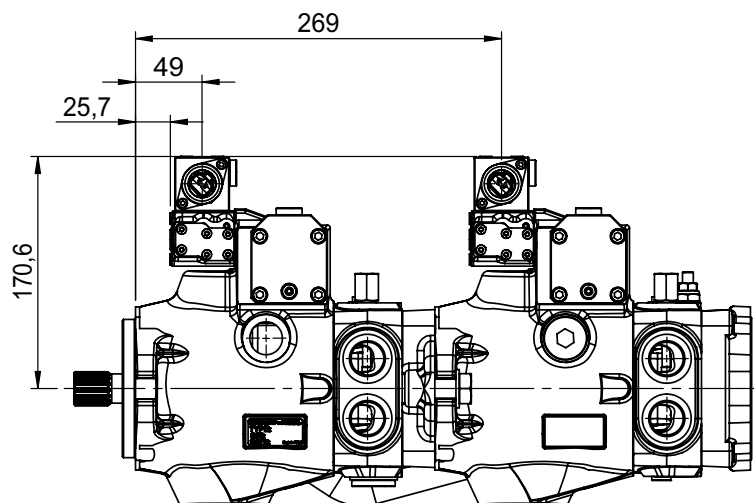

(continued)

SEIX 1.2D (12V DC)
SEIX 2.2D (24V DC)

ELECTRO-PROPORTIONAL SERVO CONTROL WITH FEED BACK

(Deutsch connector)

HYDRAULIC DIAGRAM

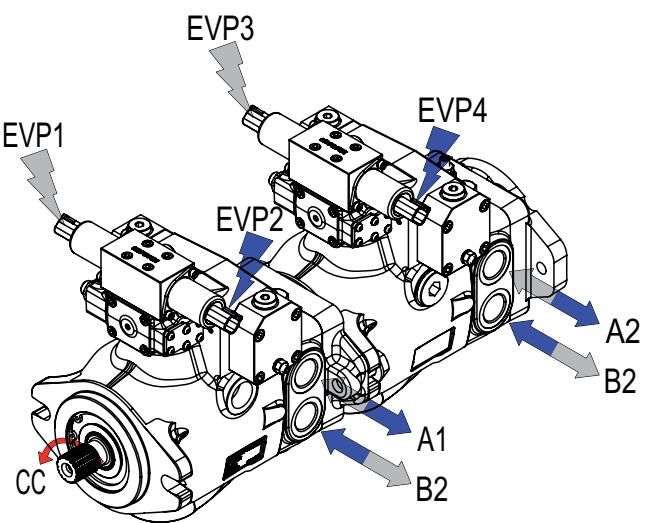
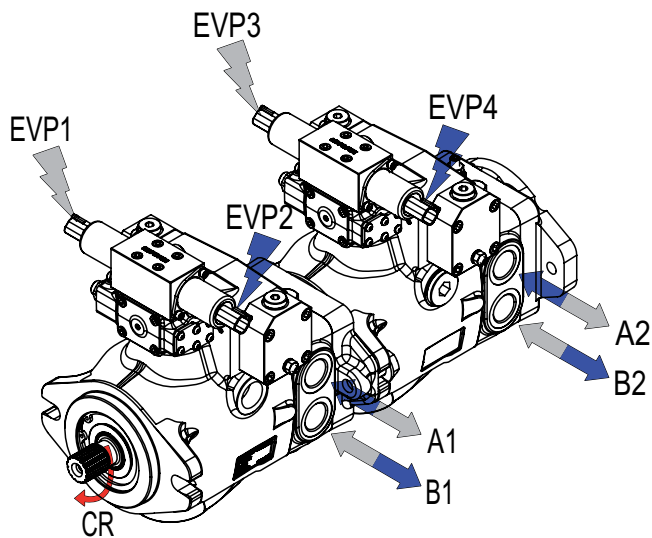
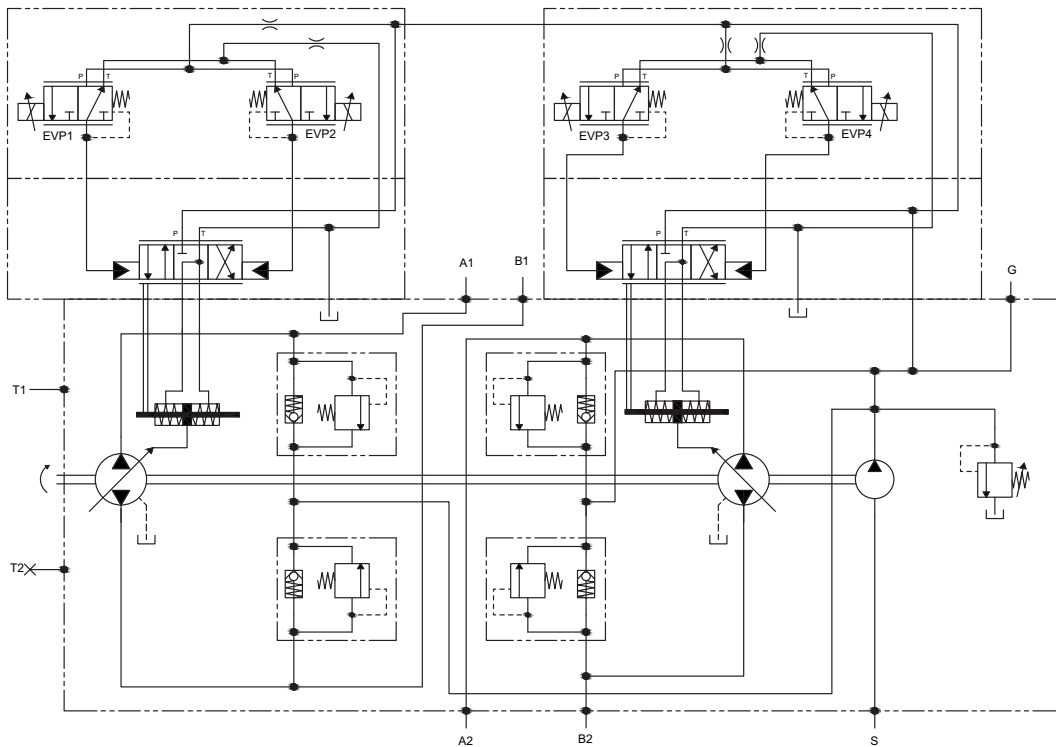

(continued)

SEIX 1.2D (12V DC)
SEIX 2.2D (24V DC)

ELECTRO-PROPORTIONAL SERVO CONTROL WITH FEED BACK

(Deutsch connector)

CURRENT-DISPLACEMENT GRAPHIC

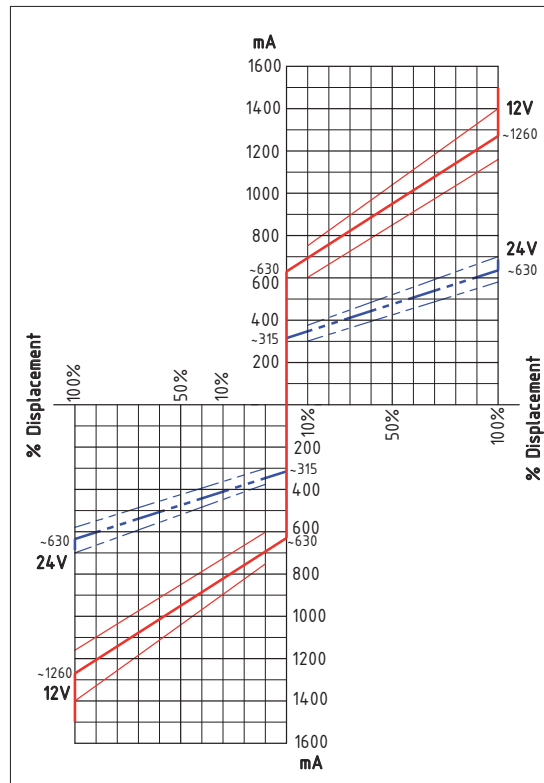

ELECTRICAL FEATURES		
Voltage	12 V DC	24 V DC
Electric current	1500 mA	750 mA
Load resistance	4,72 Ω ± 5%	20,8 Ω ± 5%
Type of control	Current control	
	PWM 100 Hz (suggested)	
Type of connection	AMP Junior Timer	
Protection class	Until IP6K6 / IPX9K	

HYDRAULIC FEATURES	
Max. pressure (P, T)	pP= 5 MPa, pT= 3 MPa
Hysteresis (w/PWM)	<0,07 MPa (pA=2,0)
	<0,1 MPa (pA=2,5)
	<0,15 MPa (pA=3,5)
Filtration ratio	125 µm
Oil contamination level	Min. filtration ratio: 20/18/15
	According ISO 4406
	Hydraulic oil DIN 51524
Min./max. oil temperature	From -20 to +90°C

REAR PUMP MOUNTING FLANGES

SA

SAE-A - 4 HOLES

Max. torque = 120 Nm

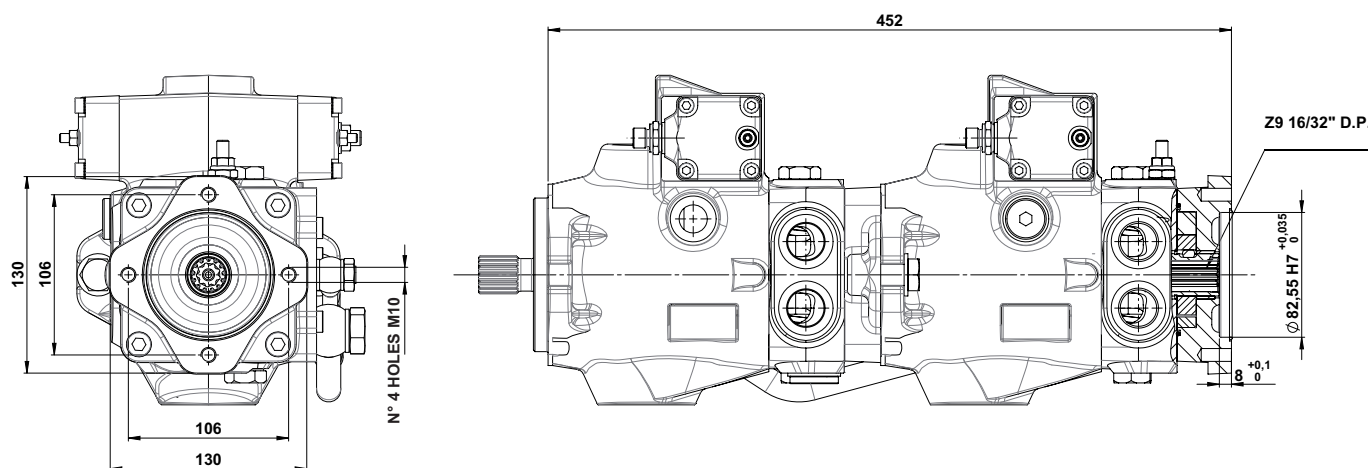

SB

SAE-B - 2 HOLES

Max. torque = 300 Nm

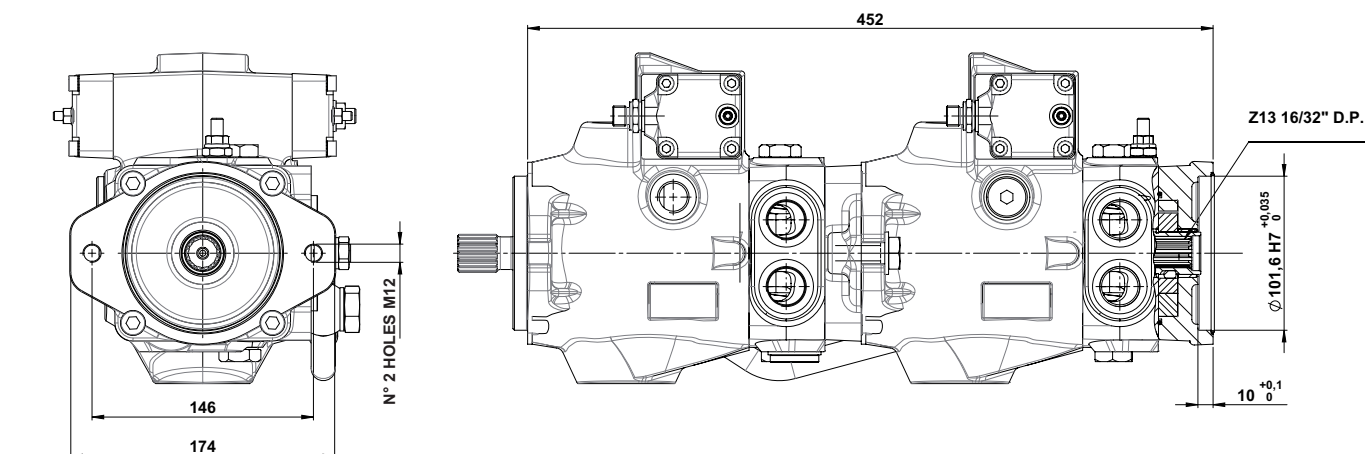

(continued)

REAR PUMP MOUNTING FLANGES

C-SA

CLOSED COVER WITHOUT REAR FITTING

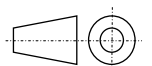
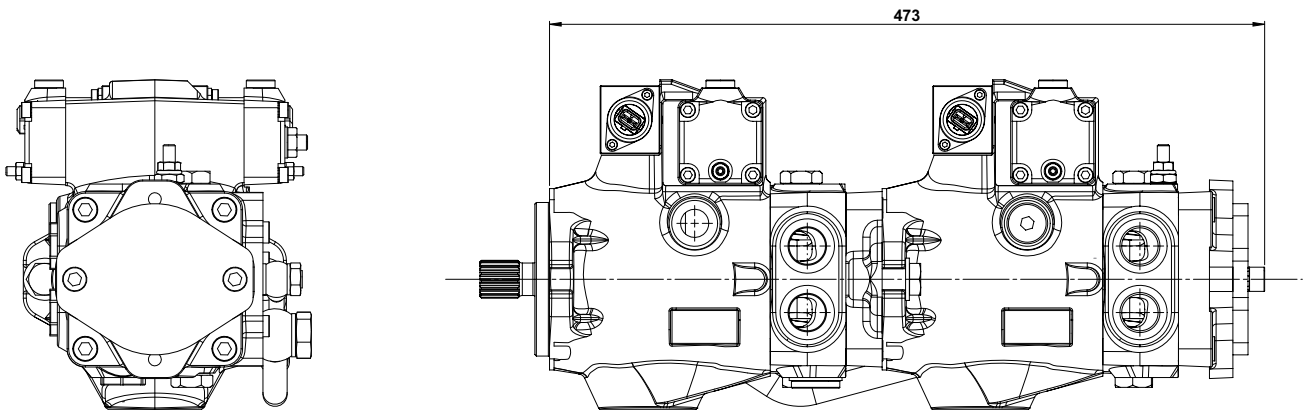

OPTIONAL SB

SCREW BY-PASS

To by pass the oil flow from one direction to the other, with the pump not running or in emergency condition, a by pass screw can be actuated to connect the 2 lines of the hydraulic system. The orifice is completely open after 4 counter-clockwise rotations of the screw.

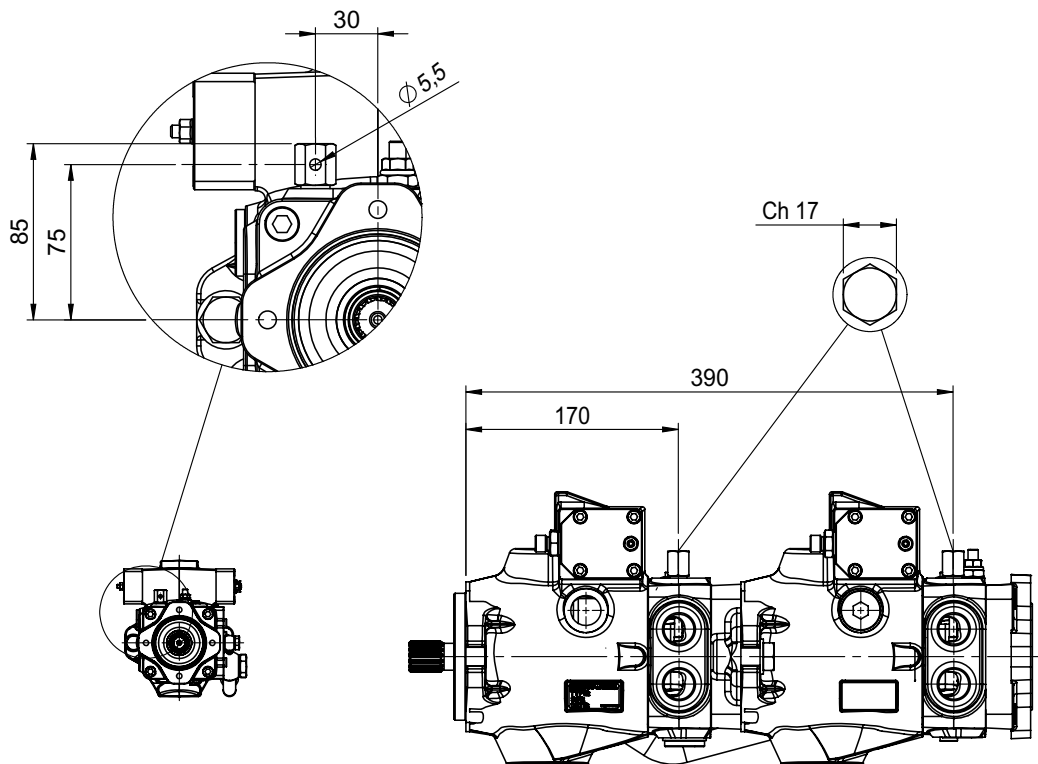

HYDRAULIC DIAGRAM

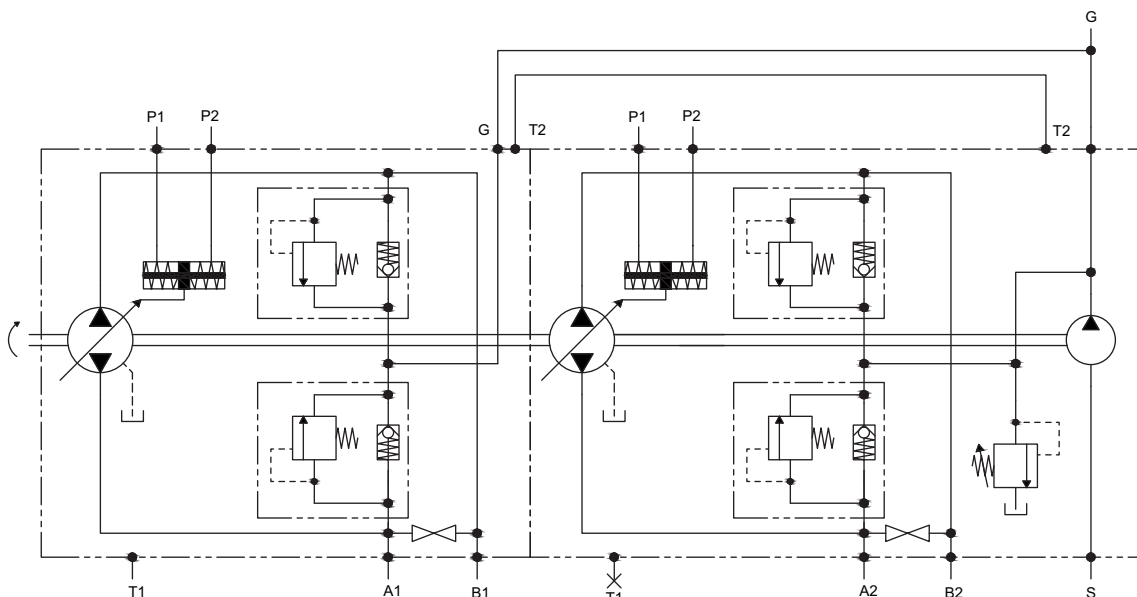

OPTIONAL FR

PRE-ARRANGED FOR CONNECTION WITH EXTERNAL FILTER

The pre-arrangement for the connection with an external filter allows the filtration of the oil of the boost pump under pressure.

The filter is not included and must be with a by-pass, filtration level 10 μm and must be of suitable size for the flow-rate of the boost pump.

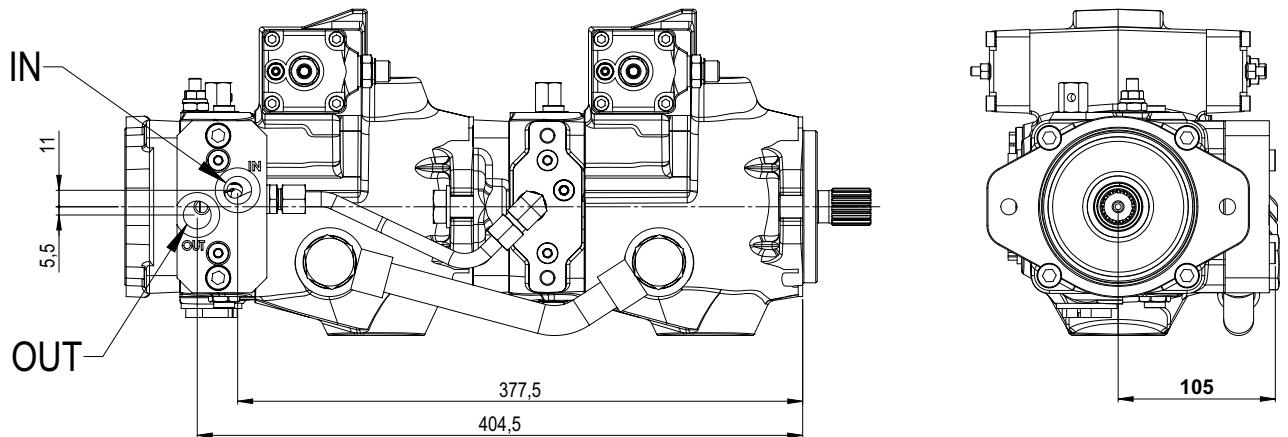

HYDRAULIC DIAGRAM

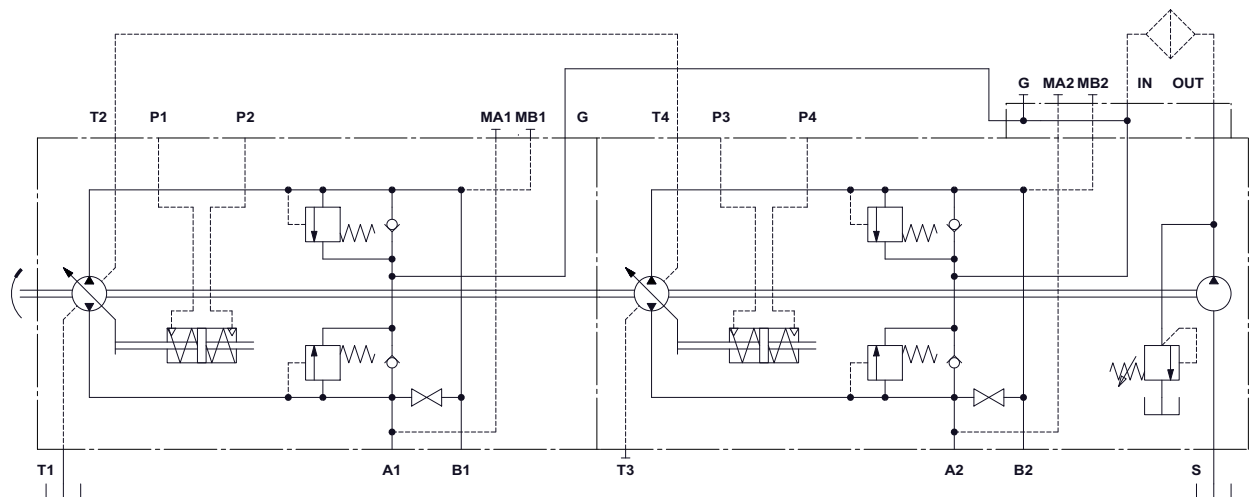

OPTIONAL MOB SHI

MAN ON BOARD

On the pump a normally open electrical operated valve can be fitted. The valve allows the flow delivery only when energized. This function is used to increase the safety of the machine. The solenoid valve is available for 12V or 24V DC voltage.

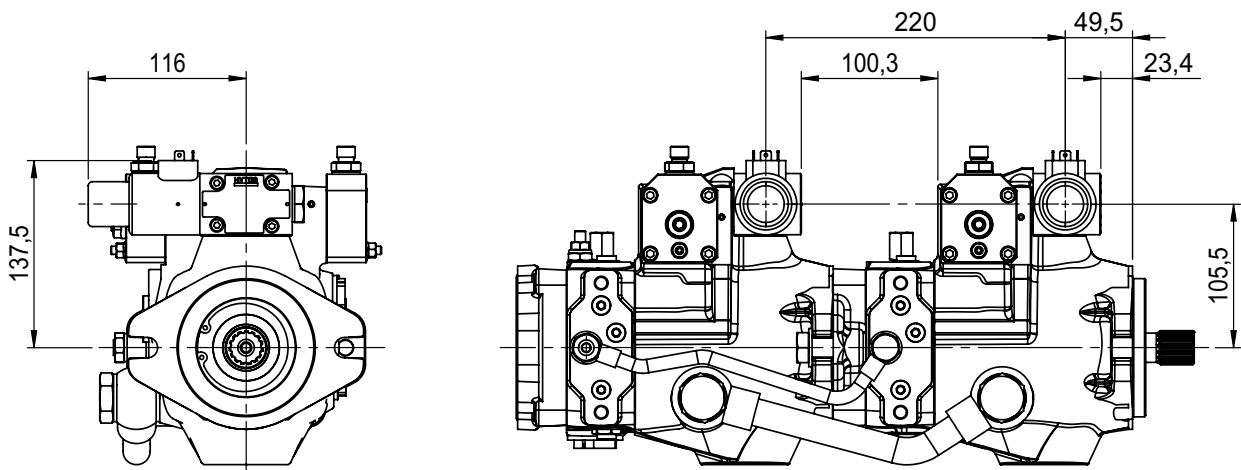

HYDRAULIC DIAGRAM

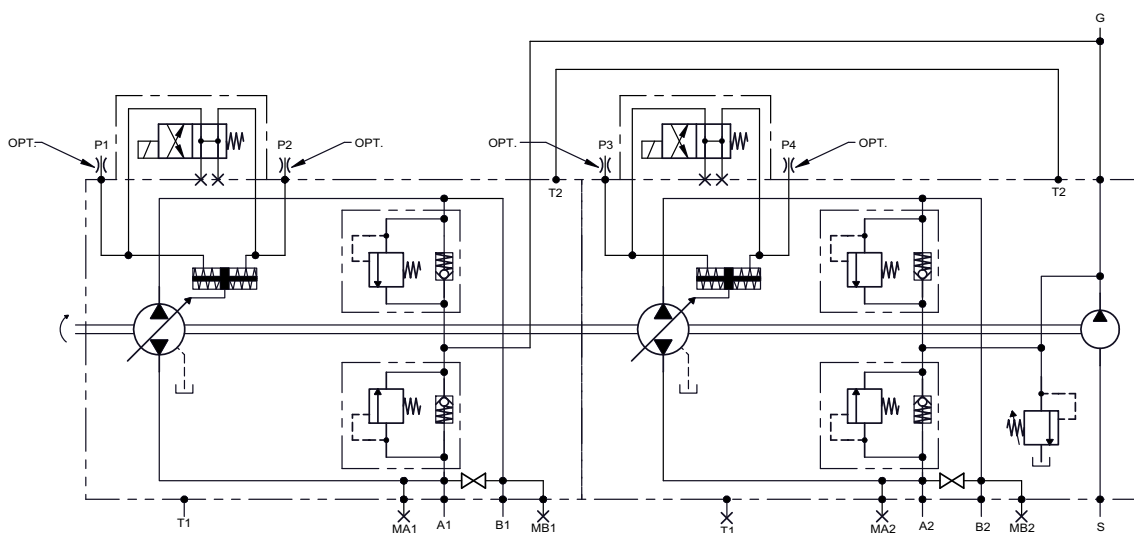

(continued)

OPTIONAL MOB SHI

MAN ON BOARD

TECHNICAL FEATURES

TECHNICAL CHARACTERISTICS	
Maximum pressure	32 MPa
Maximum flow	80 l/min.
Leakage	Max. 5 drops/Min. at 30 MPa
Response time	32 ms
Temperature	-20°C / +90°C

ELECTRIC CHARACTERISTICS	
Voltage	12V / 24V
Insulation class	IP 67
Frequency	1000 Hz
Tolerance of supply	10 - 30 DC
Ambient temperature	-30°C / +50°C
Connector *	EN 17531-803-A

* Other types of connectors are available.

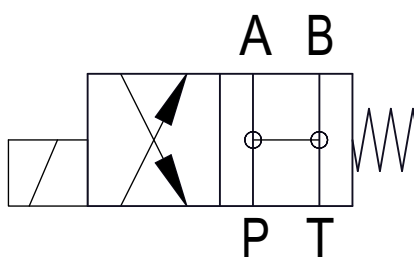

OPTIONAL MOB SEI

MAN ON BOARD

On the pump a normally open electrical operated valve can be fitted. The valve allows the flow delivery only when energized. This function is used to increase the safety of the machine. The solenoid valve is available for 12V or 24V DC voltage.

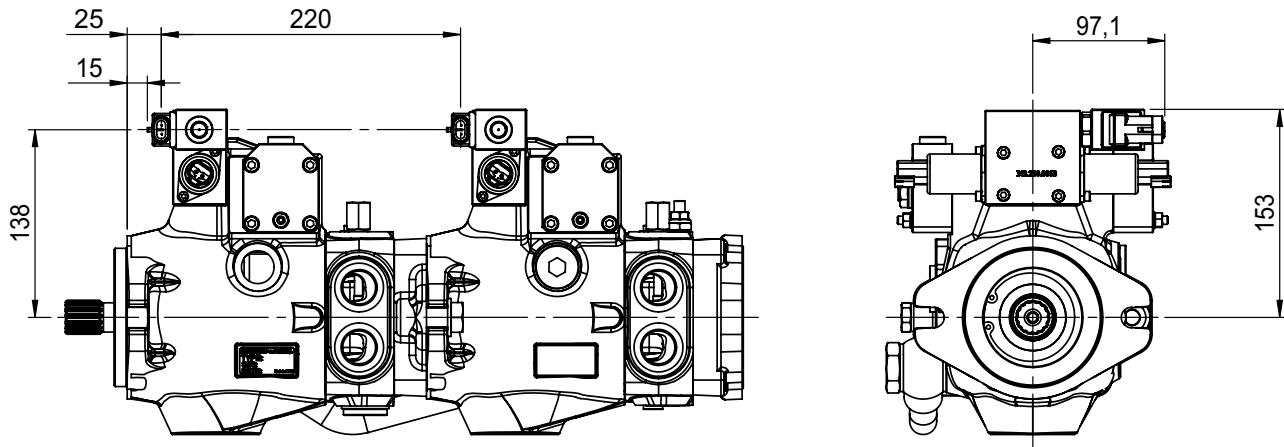

HYDRAULIC DIAGRAM

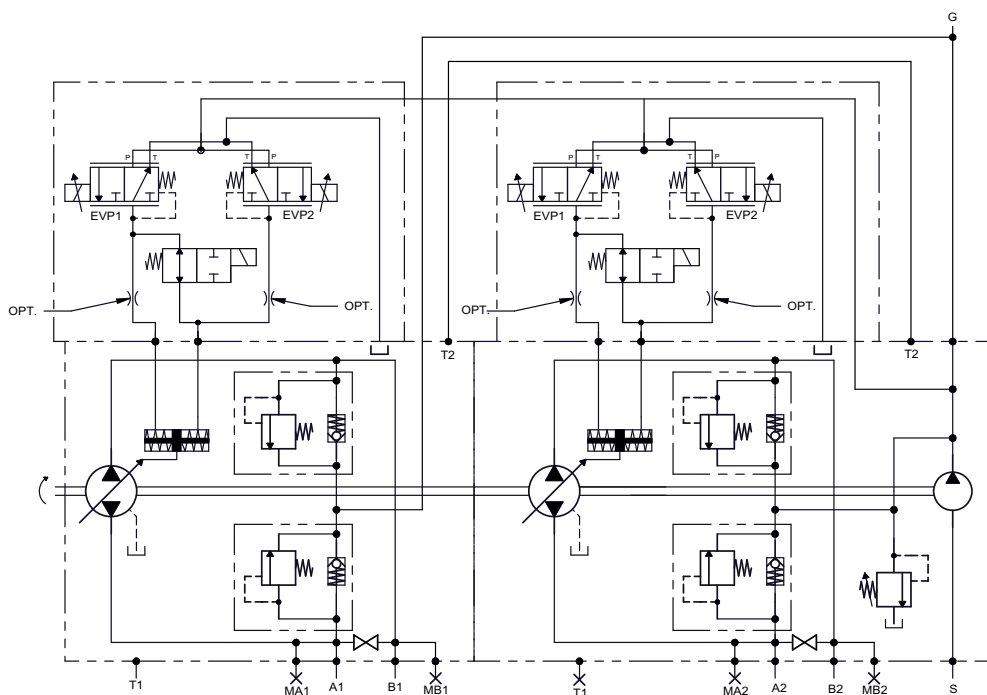

(continued)

OPTIONAL MOB SEI

MAN ON BOARD

TECHNICAL FEATURES

TECHNICAL CHARACTERISTICS	
Maximum pressure	25 MPa
Maximum flow	10 l/min.
Leakage	max. 80 cc/min. at 25 MPa
Response time	30 ms
Temperature	-30°C / +110°C

ELECTRIC CHARACTERISTICS	
Voltage	12V / 24V
Insulation class	F
Power	18W
Tolerance of supply	+10% / -5% AC
Ambient temperature	-30°C / +60°C
Connector *	DIN 43650 Deutsch (90°)

* Other types of connectors are available.

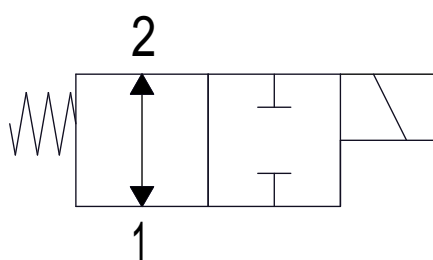

TROUBLE SHOOTING

TROUBLES	CAUSE	REMEDY
High noise level	Too high rotation speed of the pump.	Reduce pump rotation speed.
	Wrong rotation direction.	Check the rotation direction of the pump.
	Obstruction in suction line - air in the suction line - wrong oil viscosity - diameter of suction line too small.	Check oil type and viscosity. Check internal diameter of suction line. Remove restrictions. Check oil level of reservoir. Eliminate air intake.
	Not correct connection of the pump. Not correct diameter of pipes / hoses.	Check the pump connections and the pipe / hose diameters according to notes.
	Vibrations of relief valves .	Check the inlet suction line - Check and replace relief valves.
	Internal parts worn out.	Check and replace.
	Wrong pump connection to the prime mover.	Check connection and rotation of direction.
Low flow rate	Too low rotation speed of the pump.	Increase the pump rotation speed.
	Obstructions in the suction line - wrong viscosity.	Check oil type and viscosity. Check internal diameter of suction line. Remove restrictions. Check oil level of reservoir. Eliminate air intake.
	Low remote control pressure.	Check and adjust.
	High internal leakage.	Check the case drain flow.
Instable or low pressure	Low rotation speed of the pump.	Increase speed of the pump.
	Obstruction of suction line - air in the suction line - wrong oil viscosity - diameter of suction line too small.	Check oil type and viscosity. Check internal diameter of suction line. Remove restrictions. Check oil level of reservoir. Eliminate air intake.
	Vibration of relief valves.	Check the inlet suction line. Check and replace relief valves.
Over heating	Internal parts worn out.	Check and replace.
	High oil temperature at suction inlet.	Check the cooling system.
	Wrong setting of relief valves.	Check - adjust the setting of relief valves.

ACCESSORIES

Hydraulic Gear Pump **SAE A**

Hydraulic Gear Pump **SAE B**

For more detailed information ask for catalogue HT 15 F 20.....

Hydraulic Remote Servo Controls



For more detailed information ask for catalogue HT 73 B 10.....

Electric Remote Servo Controls



For more detailed information ask for catalogue HT 73 B 20.....

Flanges and Couplings for Gasoline and Diesel engines

GASOLINE OR DIESEL ENGINES

FLANGES AND COUPLINGS

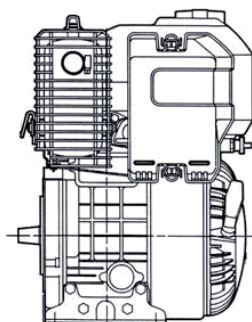
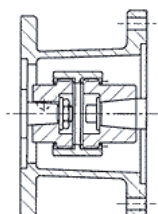

For more detailed information ask our technical department

PUMPS



Closed Loop Axial Piston Pumps (Variable Displacement) - 6-110 cc

Model	Displacement cm ³ /n.	Rated Pressure MPa	Peak Pressure MPa	Maximum speed n/min.	Weight kg (single pump)
TPV 1000 TPV 1200 BTB	6, 8, 9, 11, 12, 13	21	30	3.600	8,8
	15, 17		28		
	18		27		
	19, 21	20	25	3.200	
TPV-TPVTC 1500	17, 18, 19, 21	35	40	3.600	14
TPV 3200	21, 28	25	35		22
TPV-TPVT 3600	26, 28, 30, 31, 32, 34, 36, 38	35	45		28
TPV 4300	32, 38, 45, 50	25	35		23
TPV 5000	46, 50, 64	30	40		29
TPV 9000	55	40	45		4.000
	72			4.100	68
	90			4.000	
	110			3.800	



Open Loop Axial Piston Pumps (Fixed Displacement) - 32-50 cc

Model	Displacement cm ³ /n.	Rated Pressure MPa	Peak Pressure MPa	Maximum speed n/min.	Weight kg (single pump)
TPF 60	35, 40, 46	35	42	2.800	20,5
	50		41	2.500	



Bent Axis Pumps - 12-130 cc

Model	Displacement cm ³ /n.	Rated Pressure MPa	Peak Pressure MPa	Maximum speed n/min.	Weight kg
TPB - TAP 70	12.6	35	40	3.300	7,5
	17.0			3.200	
	25.4			2.550	8,5
	34.2			2.250	
	41.2, 47.1			2.200	15,5
	56.0			2.100	
	63.6			2.050	
	83.6, 90.7, 108.0			1.700	
	130.0			1.600	29,5

The table values can change in function of the configuration.

As HANSA-TMP has a very extensive range of products and some products have a variety of applications, the information supplied may often only apply to specific situations.

If the catalogue does not supply all the information required, please contact HANSA-TMP.

In order to provide a comprehensive reply to queries we may require specific data regarding the proposed application.

Whilst every reasonable endeavour has been made to ensure accuracy, this publication cannot be considered to represent part of any contract, whether expressed or implied.

The data in this catalogue refer to the standard product.

The policy of HANSA-TMP consists of a continuous improvement of its products. It reserves the right to change the specifications of the different products whenever necessary and without giving prior information.



HYDRAULIC COMPONENTS
HYDROSTATIC TRANSMISSIONS
GEARBOXES - ACCESSORIES

Via M. L. King, 6 - **41122 MODENA (ITALY)**

Tel: +39 059 415 711

Fax: +39 059 415 730

INTERNET: <http://www.hansatmp.it>

E-MAIL: hansatmp@hansatmp.it