



HYDRAULIC COMPONENTS
HYDROSTATIC TRANSMISSIONS
GEARBOXES - ACCESSORIES



Certified Company ISO 9001:2015 - 14001:2015

ISO 9001:2015 Certificate N° 12-Q-0200545-TIC
ISO 14001:2015 Certificate N° 12-E-0200545-TIC

Via M. L. King, 6 - 41122 MODENA (ITALY)

Tel: +39 059 415 711

Fax: +39 059 415 730

INTERNET: <http://www.hansatmp.it>

E-MAIL: hansatmp@hansatmp.it

HT 16 / M / 4016 / 1218 / E

THE PRODUCTION LINE OF HANSA-TMP

Variable Displacement Closed Loop System Axial Piston Pump

TPV - TPVT 3600

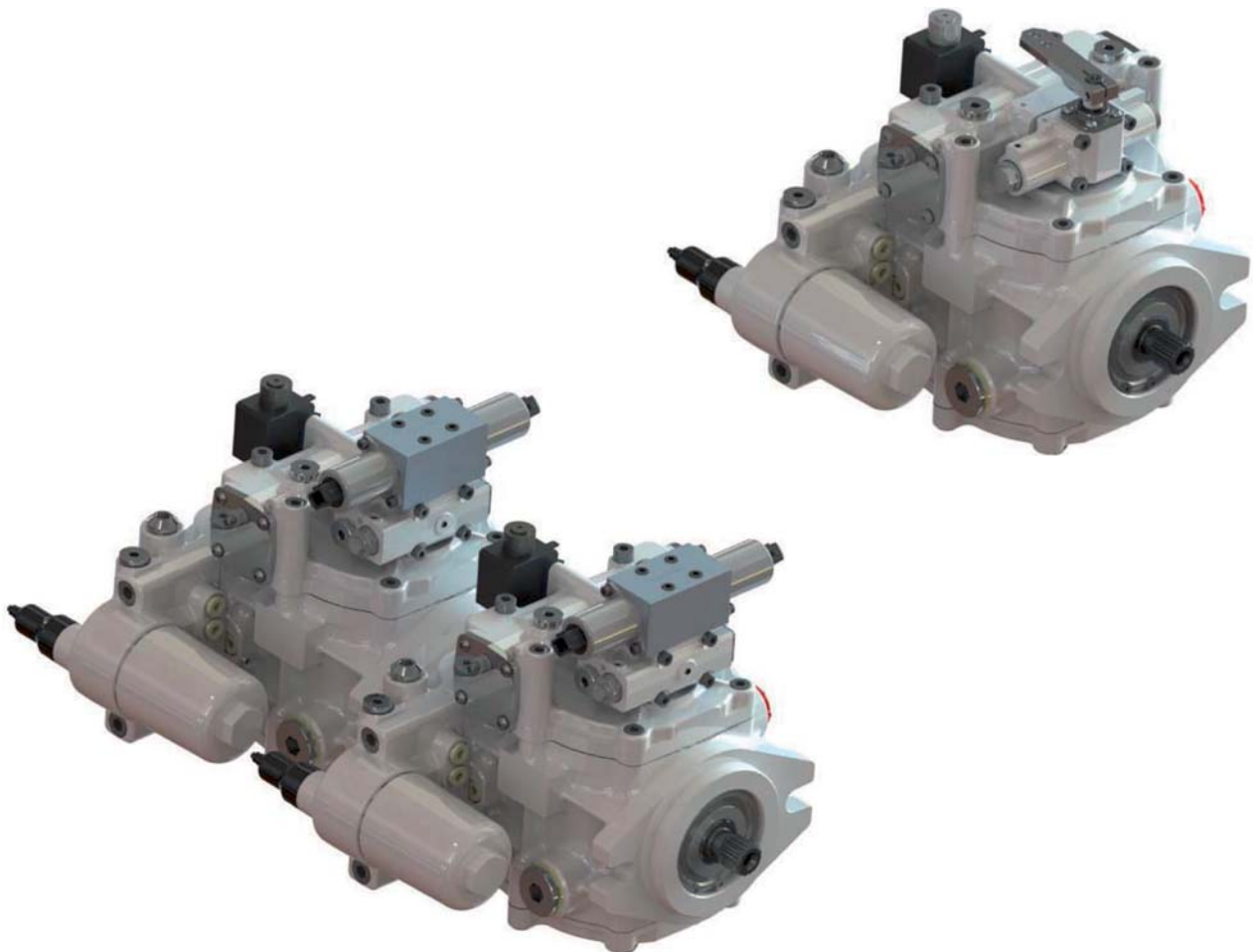

INDEX

General information.....	5
Technical specifications.....	6
System design parameters.....	7
Performance diagram.....	8
Hydraulic diagram.....	9
Installation instructions.....	10 - 11
Hydraulic fluid.....	12
Hydraulic fluid filtration.....	13
TPV 3600	
Order code.....	16 - 18
General dimensions pump.....	19
Shaft option and mounting flanges.....	20
SHI Hydraulic servo control.....	21 - 22
SEI 1.3 - 2.3 Electro-proportional servo control.....	23 - 25
SEI 1.3D - 2.3D Electro-proportional servo control.....	26 - 28
SHIX Hydraulic servo control with feed back.....	29 - 30
SMIX Manual lever control with feed back.....	31 - 32
SEIX 1.3 - 2.3 Electro-proportional servo control with feed back.....	33 - 35
SEIX 1.3D - 2.3D Electro-proportional servo control with feed back.....	36 - 38
Main ports position.....	39
Rear pump mounting flanges.....	40 - 41
Optional LB Lever by-pass.....	42
Optional VS Purge valve.....	43
Optional CO (--) Pressure cut-off valve (pressure setting).....	44
Optional FR Pre-arrangement for external filter-connection.....	45
Optional FLT Filter without clogging indicator.....	46
Optional FLTI Filter with clogging indicator.....	47
Optional MOB Man on board.....	48 - 49
Optional RS Angle sensor.....	50 - 51
Optional REV.S Speed sensor.....	52 - 53
Optional PRS Pressure sensor.....	54 - 55
TPVT 3600	
Order code.....	58 - 61
General dimensions tandem pump TPVT1 with single boost pump.....	62
General dimensions tandem pump TPVT2 with double boost pump.....	63
Examples tandem pumps.....	64 - 65
Assembly example with various optionals.....	66

GENERAL INFORMATION

- The new TPV-TPVT 3600 pumps are variable displacement axial piston pumps with swash-plate system, for closed loop hydrostatic transmissions, that offer the best power to weight ratio because of new innovative design and production technologies.
- The flow rate is proportional to the rotation speed and is continuously variable according to the angle of the swash-plate from "0" to maximum displacement.
- The TPV-TPVT 3600 pumps are equipped with a boost pump, "gerotor" type of new design and high efficiency to keep the circuit pressurised, to compensate the oil leakages of the hydrostatic transmission, to avoid cavitation of the piston pump and to supply low pressure oil flow to the remote controls of the pumps and of the hydraulic transmission (max 3 MPa).
- Different types of hydraulic or electro-proportional controls are available for remote regulation of the pump displacement by means of hydraulic or electric joysticks.
The mounting flange is according to SAE-B 2 bolt, the through-drive is according SAE-A 2 bolt.
Different other optionals are available for the TPV-TPVT 3600 pumps.
- The piston pumps are to be considered as individual components for the purposes of Directive 2006/42/EC, therefore have been built to be integrated into a circuit or to be assembled with other components to form a machine or system. They can be operated only after they have been installed in the machine/system which they are intended for.
- The TPV-TPVT 3600 pumps must be used to create, manage and regulate oil flow in a closed loop system. Any other use should be considered improper.
- The pumps are built according to the technology normally used for this type of product. There is the risk of injury or damage to personnel during their installation and use if you do not respect the normal safety instructions or if used by untrained personnel.

TECHNICAL SPECIFICATIONS

The housing and the distributor of the TPV-TPVT 3600 pumps are made in cast iron. The flow rate is proportional to the rotation speed and the displacement is continuously variable. It increases as the swash-plate angle moves from "0" to maximum position.

If the swash-plate is positioned out of the neutral position, the flow respectively follows one of the two directions.

Key features

- compact design
- integrated optionals
- high power to weight ratio
- low noise integrated boost pump

Typical applications

- construction equipments
- green mowers
- zero turn machines
- agricultural machines
- utility vehicles
- forest vehicles
- logistic machines

Technical Specifications

Pump model		TPV 26	TPV 28	TPV 30	TPV 32	TPV 34	TPV 36	TPV 38
Displacement	cc/rev.	26	28	30	32	34	36	38
Flow rating (at 3.000 n/min 40 MPa)	l/min-1	74,9	80,6	86,4	92	97,8	103,7	109,4
Power rating (at 3.000 n/min 40 MPa)	kW	59	63	68	72	77	81	86
Boost pump displacement	cm ³ /n	10,3						
Continuous working pressure	MPa	40						
Max pressure	MPa	42						
Max relief valve setting	MPa	45						
Boost pressure relief valve setting	MPa	2 (at 1.000 n/min)						
Suction pressure	MPa	>/= 0,008						
Max housing pressure	MPa	0,2						
Minimum rotation speed	n/min	500						
Maximum rotation speed	n/min	3600						
Max fluid temperature	°C	80°						
Fluid viscosity	cSt	15-40						
Fluid contamination level		19/17/14 ISO 4406 (NAS 8)						
Mass (single pump with SHI basic version)	Kg	26						
Mass (double pump with SHI basic version)	Kg	54						

SYSTEM DESIGN PARAMETERS

HYDRAULIC MEASURE	USEFUL FORMULAS	CONVERSION FACTORS
Flow rate: Q = (l/min)	$Q = V [cm^3/n] \times \eta_v \times n \times 10^{-3}$	1 l/min = 0,2641 US gpm
Pressure: P = (MPa)		1 MPa = 145 PSI
Displacement: V = (cm ³ /n)		
Torque: M = (Nm)	$M = \frac{\Delta p [MPa] \times V [cm^3/n]}{6.283 \times \eta_m}$	1 Nm = 8,851 lbs.in
Power: P = (kW)	$P = \frac{\Delta p [MPa] \times V [cm^3/n] \times n}{60 \times 1000 \times \eta_t}$	1 kW = 1,36 hp
Shaft speed: n = n/min		
Volumetric efficiency: = η_v		
Mechanical efficiency: = η_m		
Overall efficiency: = η_t		
		1 mm = 0,0394 in
		1 kg = 2,205 lbs
		1 N = 0,2248 lbs

PERFORMANCE DIAGRAM

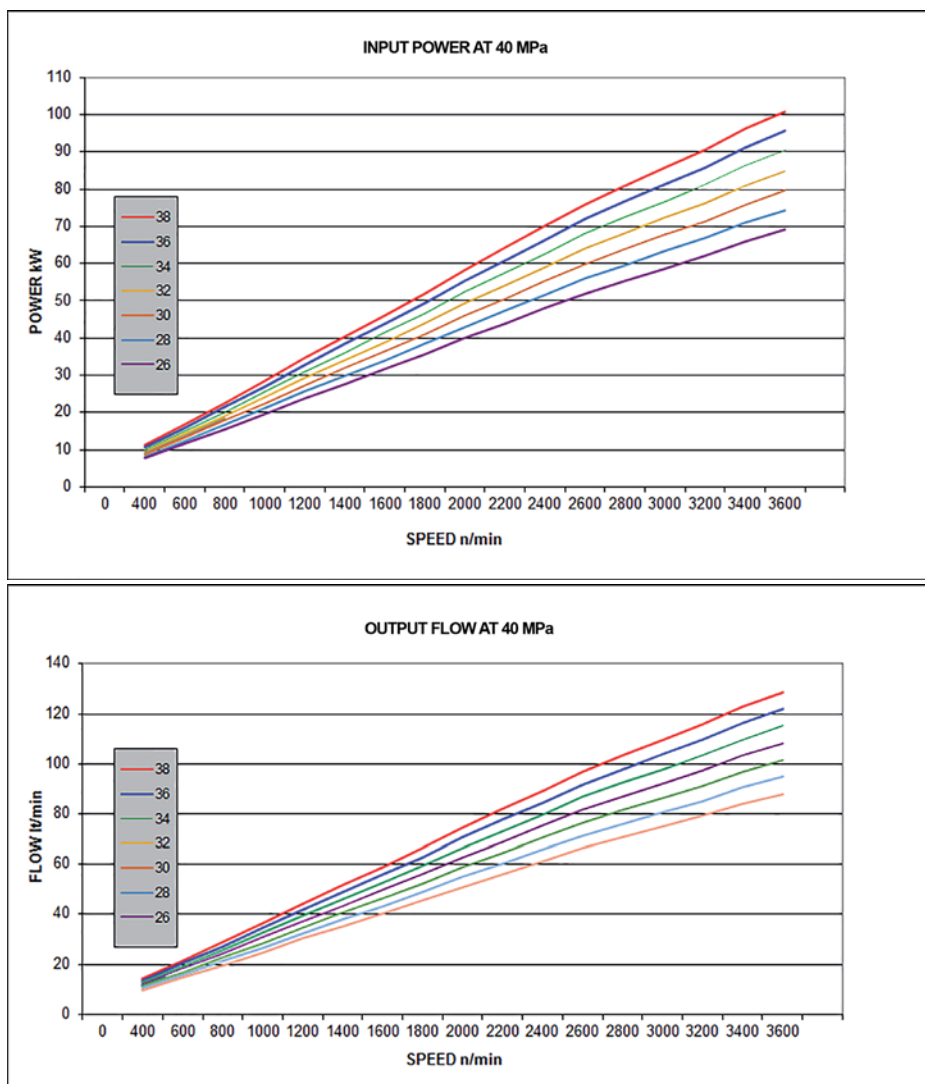

Performance diagrams

- The diagrams show the data of maximum speed and maximum continuous pressure.
- Data may vary depending on pump displacement.

Pressure

- Continuous pressure: is the average pressure for continuous work, which must not be exceeded, to ensure a correct and long lasting service of the pump.
- Maximum pressure: is the maximum allowable pressure for short periods and must never be exceeded.

Speed

- Continuous work speed: is the maximum

recommended speed for continuous operation of the pump under full load.

- Maximum speed: is the maximum permissible speed for the pump for short periods and not fully loaded. The use of the pump with this speed can reduce the life and cause a loss of power or of the hydrostatic braking capacity.

Caution

Any damage caused to the pump can reduce or eliminate the hydrostatic braking capacity. It is therefore necessary to provide an auxiliary braking system capable of stopping and supporting the weight of the complete machine, in the event of loss of hydrostatic power.

HYDRAULIC DIAGRAM

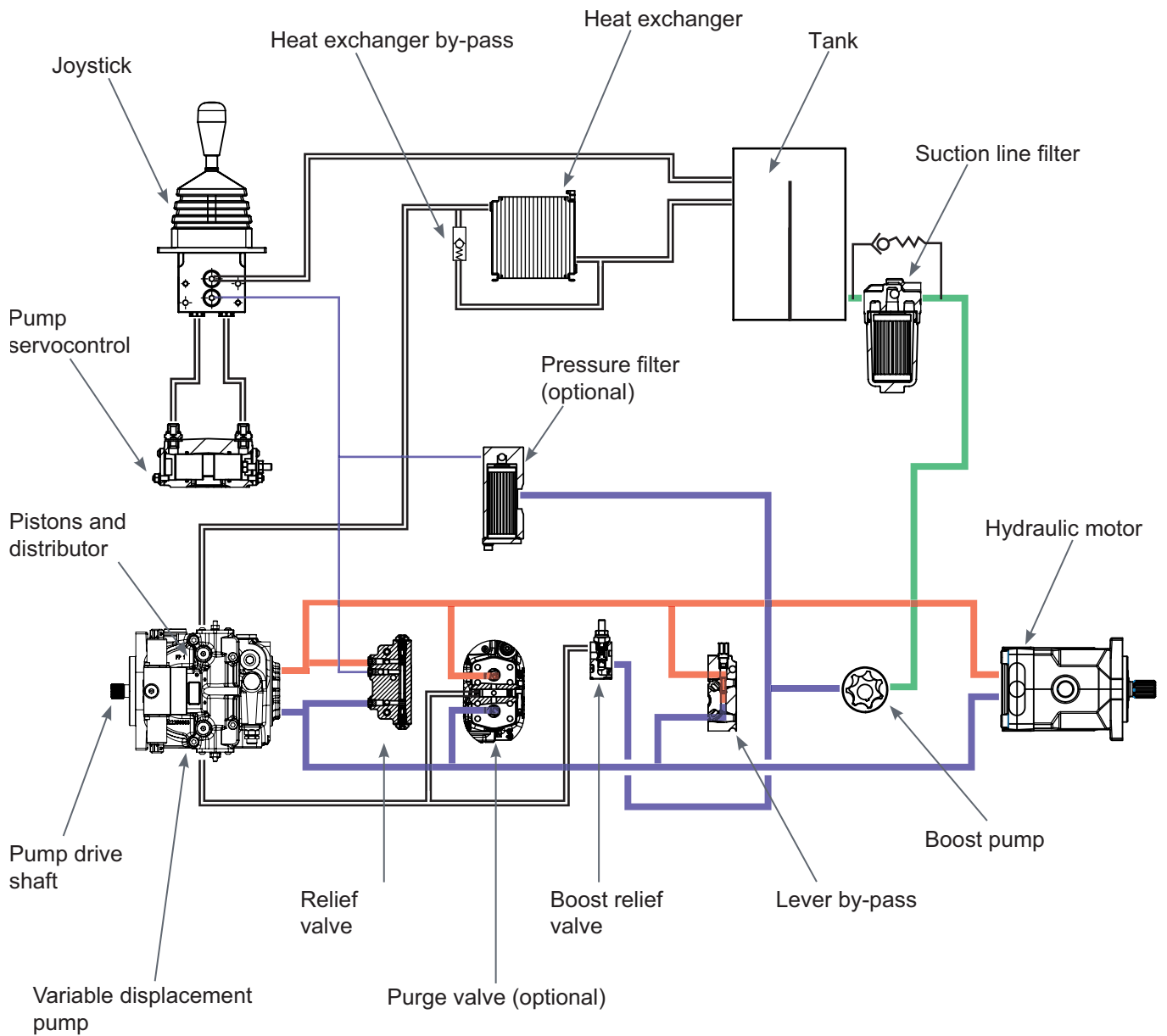

COLOR INDICATIONS

- LOW PRESSURE AND PILOT LINE
- PRESSURE LINE
- SUCTION LINE
- DRAIN / RETURN LINE

INSTALLATION INSTRUCTIONS

Standards for the installation, start up and maintenance

- When mounting the pump above the minimum level of the tank, distance of the highest point of the pump over the oil level **MUST NOT** exceed 250 mm.
- To reduce the noise level typical of all piston pumps we recommend:
 - use hoses instead of pipes
 - limit to a minimum the length of eventual pipes
 - fix rigid pipe sections with special supports equipped with rubber vibration dampening devices
 - use pipes and hoses with a diameter according to the speed values below:

Suction line = 0,6 ÷ 1,2 m / s

Drain = 1,5 ÷ 3,6 m / s

Pressurized lines = max 6 m / s

- To calculate the speed of the oil in the lines refer to the formula below:

$$V = Q * 21,22 / D$$

V = speed (m/s)

Q = flow rate (l/min)

D = internal pipe/hose diameter (mm)

- In any case **NEVER** use pipes/hoses or fittings with diameter smaller than that of the corresponding ports on the pump. This indication is **ABSOLUTELY OBLIGATORY** for the drain line to avoid to pressurize the pump housing and extrude the lip seal of the pump shaft.
- During mounting cure the alignment of the pump, concentric with the drive shaft sleeve to prevent overloading of the bearing. See page 11.
- For the hydraulic system, we recommend using pipes/hoses washed internally with hydraulic oil or, even better, with solvent.
- Special care must be taken when cleaning the inside of the tank (painting is recommended after sand blasting).
- To improve the functionality of the boost pump, it is recommended to place it below minimum tank level.
- The pumps can be installed in any direction and position.
For further information contact our Technical Department.

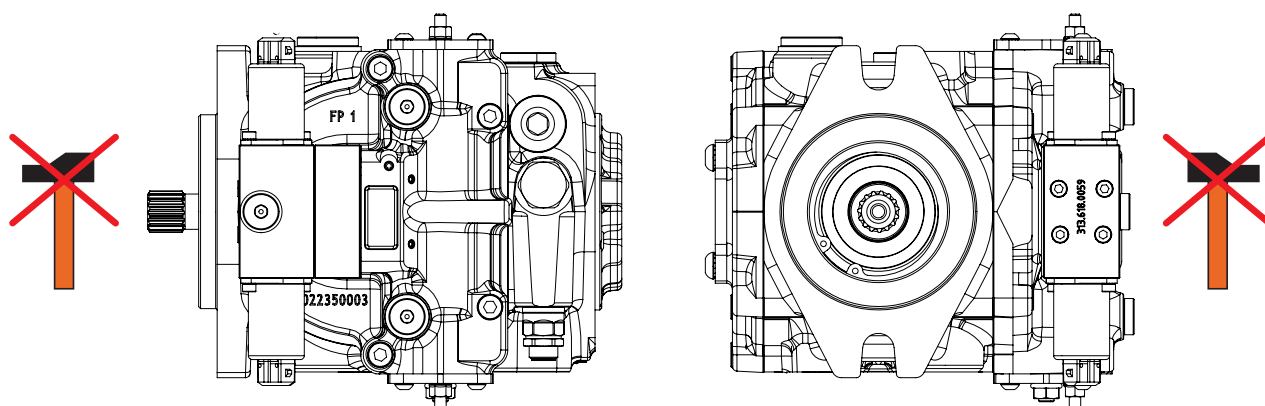

(continued)

INSTALLATION INSTRUCTIONS**Shaft Coupling**

To connect the pump shaft to the engine flywheel or electric motor shaft use a flexible coupling.

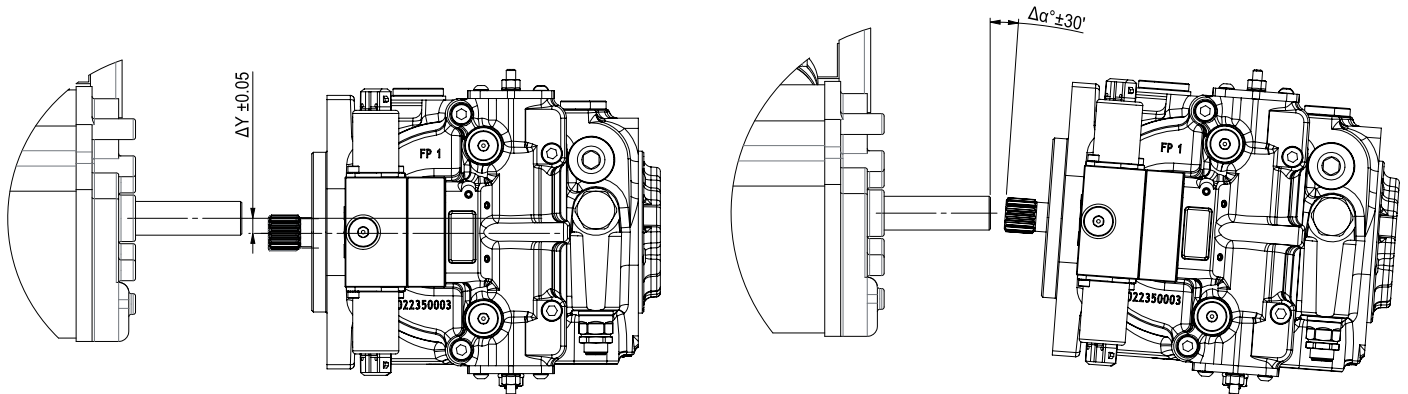

For an optimal function of the pump the shaft should not be subjected to radial or axial loads. During the installation or removal, do not force the coupling of the pump shaft, but always use the threaded hole on the shaft.

Start up

- Before starting fill the tank and the other components with new filtered oil. You should run a flushing of the complete hydraulic system (see Use and Maintenance Manual). Check that the low pressure value is correct (refer to the Use and Maintenance Manual).
- Restore the oil level in the tank.

Maintenance

- The first oil change should be made after 500 hours of operation. Later change the oil every 2000 hours.
- The first replacement of the filter cartridge has to be made after 50 hours for a preliminary circuit cleaning. Then after further 500 hours.
- These frequencies have to be reduced in the case where the indicator shows the clogging of the filter cartridge and in case of operation in environments with a high level of contamination.

CAUTION

- Always work with the utmost attention to the moving parts; do not use loose or fluttering clothing.
- Do not approach rotating wheels, tracks, chains or shafts if not properly protected, or when they may start moving without notice.
- Do not loosen or disconnect fittings and pipes/hoses while the engine is running.
- Avoid oil leaks in order to prevent environmental pollution.

Load capacity of rear shaft (through drive shaft)

- The rear shaft is not able to carry radial loads.

HYDRAULIC FLUID

Viscosity

The maximum duration and the maximum efficiency are related to the optimum range of viscosity.
Optimal operating viscosity 15 ÷ 40 cSt referred to the temperature of the closed circuit.

and with the maximum temperature of the drain oil at 90 °C.
Max. viscosity = 1000 cSt for a few seconds, only during cold starting.

Working conditions

For working conditions apply the following limits:
Minimum viscosity = 10 cSt for short moments

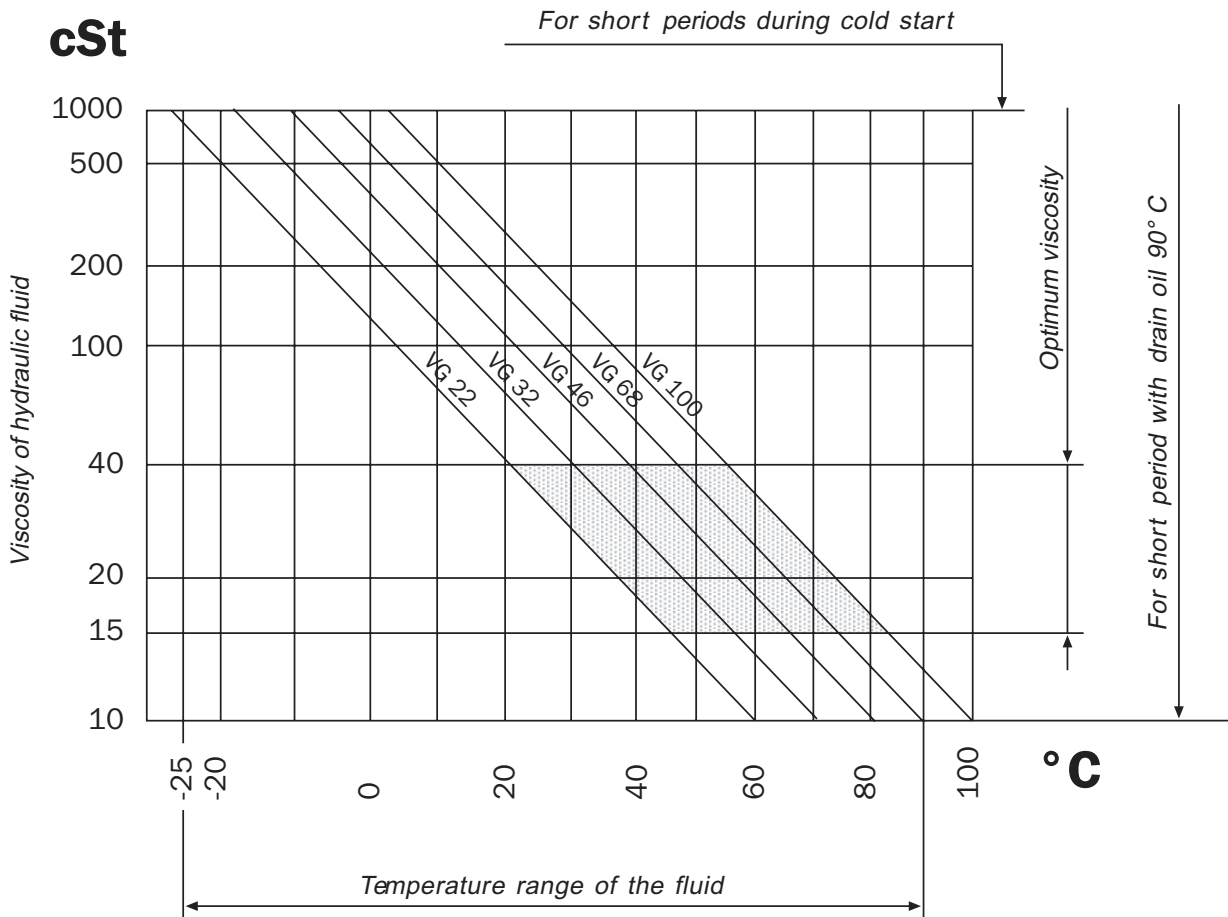

HANSA-TMP cannot be held responsible concerning non compliance of these instructions and observance of safety regulations, although not covered by this document.

HYDRAULIC FLUID FILTRATION

The contaminating particles suspended in the hydraulic fluid cause the wear of the hydraulic mechanisms moving parts.

On hydraulic pumps these parts operate with very small dimensional tolerances.

In order to prolong the parts life, it is recommended to use a filter that maintains the hydraulic fluid contamination class at max.

8 according to NAS 1638
5 according to SAE, ASTM, AIA
19/17/14 according to ISO 4406

According to the type of application decided for the pump, it is necessary to use filtration elements with a filtration ratio of:

$$\beta_{(x)} 20 \div 30 \geq 75$$

making sure that this ratio does not worsen together with the increasing of the filter cartridge differential pressure. While the pump is working, its temperature increases (over 80° to 110°C) with negative effects on pump performances; as a consequence, it is important to observe a max. contamination level of:

7 according to NAS 1638
4 according to SAE, ASTM, AIA
18/16/13 according to ISO 4406

If these values cannot be secured, the component life will consequently be reduced and it is recommended to contact our Tech. Dept.

Suction filters

The suction filters must have a clogging indicator and bypass. The max. pressure drop of the filtration element must not exceed 0,04 absolute MPa (0,08 absolute MPa with cold start).

Filter assembling

The suction filter is mounted in the suction line. Check that the pressure before the boost pump is 0,08 absolute MPa, measured on the

pump suction port (0,05 MPa for cold starting).

TPV 3600

VARIABLE DISPLACEMENT AXIAL PISTON PUMP

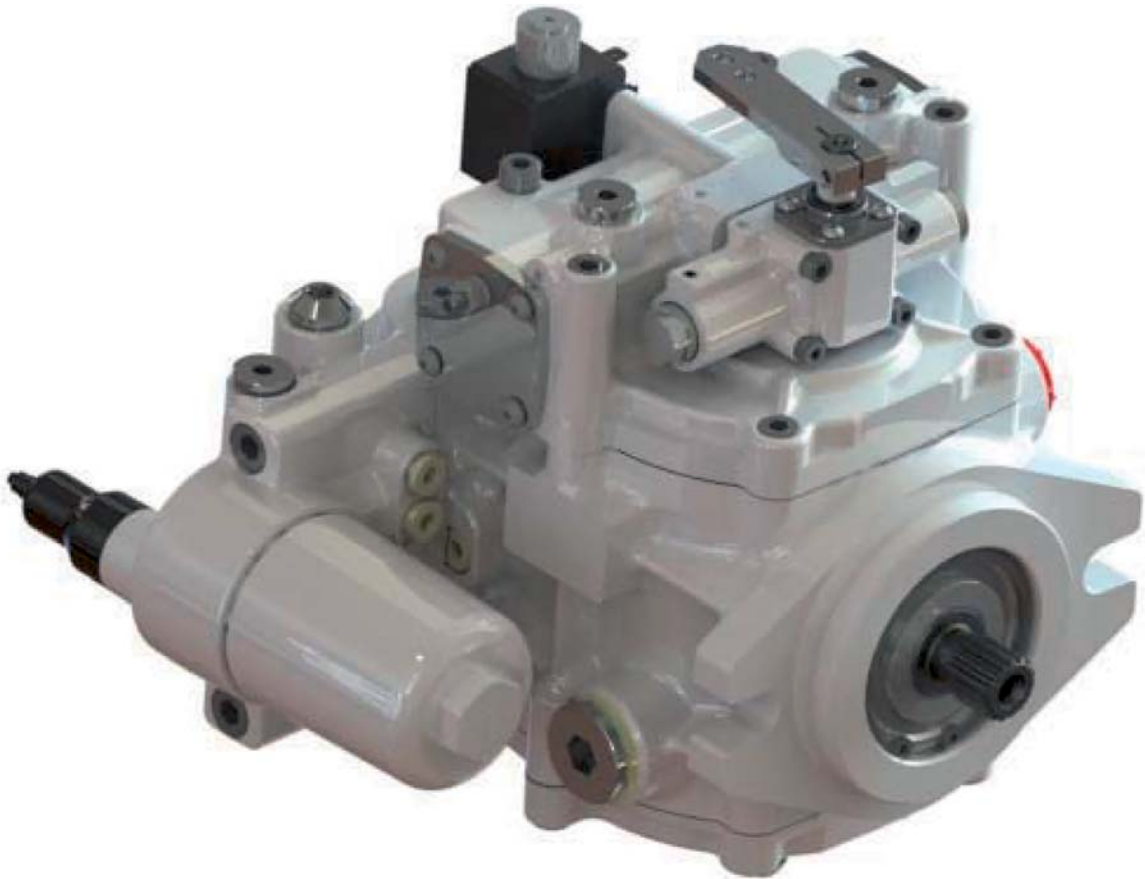

ORDER CODE _____

3600	TPV	38	CR	SS3	F2	SMIX	OA	20	10	C	000	0	LB	N
0	1	2	3	4	5	6	7	8	9	10	11	12	13	14

Page

3600	0 - Pump series = Series 3600	
TPV	1 - Pump model = Single closed loop circuit pump	
	2 - Pump displacement	
	26 = 26 cm ³ /n	28 = 28 cm ³ /n
	34 = 34 cm ³ /n	36 = 36 cm ³ /n
		30 = 30 cm ³ /n
		38 = 38 cm ³ /n
CR	3 - Pump rotation = Clockwise Rotation (right)	
CC	= Counter-clockwise rotation (left)	
SS3	4 - Shaft (mounting side) = Splined shaft SAE-B (ANSI B92.1A - 13T - 16/32 D.P.)	20
SS5	= Splined shaft SAE-BB (ANSI B92.1A - 15T - 16/32 D.P.)	20
F2	5 - Mounting flange = SAE-B 2 holes - pilot diam. 101,6 mm.	20
SHI	6 - Control devices = Hydraulic servo control	21
SEI1.3	= Electro-proportional servo control 12V DC (AMP junior timer connector)	23
SEI2.3	= Electro-proportional servo control 24V DC (AMP junior timer connector)	23
SEI1.3D	= Electro-proportional servo control 12V DC (Deutsch connector)	26
SEI2.3D	= Electro-proportional servo control 24V DC (Deutsch connector)	26
SHIX	= Hydraulic servo control with feed back	29
SMIX	= Mechanical lever servo control with feed back	31
SEIX1.3	= Electro-proportional servo control with feed back 12V DC (AMP junior timer connector)	33
SEIX2.3	= Electro-proportional servo control with feed back 24V DC (AMP junior timer connector)	33
SEIX1.3D	= Electro-proportional servo control with feed back 12V DC (Deutsch connector)	36
SEIX2.3D	= Electro-proportional servo control with feed back 24V DC (Deutsch connector)	36
OA	7 - Control devices position = Position A	39
OB	= Position B (On request only, minimum 50 pcs per order)	39
	8 - Relief valve settings	
	10 = 10 MPa	15 = 15 MPa
	25 = 25 MPa	30 = 30 MPa
	45 = 45 MPa	18 = 18 MPa
		35 = 35 MPa
		20 = 20 MPa
		40 = 40 MPa

(continued)

ORDER CODE _____

3600	TPV	38	CR	SS3	F2	SMIX	OA	20	10	C	000	0	LB	N
0	1	2	3	4	5	6	7	8	9	10	11	12	13	14

Page

9 - Boost pump

- 00 = Without boost pump *
- 10 = Standard boost pump 10,3 cm³/n - pressure 2 MPa at 1.000 n/min.
- 10 (XX) = Standard boost pump 10,3 cm³/n - other pressure setting 2÷3 MPa at 1000 n/min., please contact our technical department for details

* Upon order, please provide information on maximum external charge flow.

10 - Rear pump connection options

- C = Closed cover 40
- B1 = German standard pump group 1 mounting 40
- SA = SAE-A 2 holes mounting flange (9T 16/32 D.P. female shaft) 41
- SB = SAE-B 2 holes mounting flange (13T 16/32 D.P. female shaft) 41

11 - Auxiliary gear pump displacements

- 000 = Without gear pump

Group 1

- 112 = 1,2 cm³/n 117 = 1,7 cm³/n 122 = 2,2 cm³/n 126 = 2,6 cm³/n
- 132 = 3,1 cm³/n 138 = 3,6 cm³/n 143 = 4,2 cm³/n 149 = 4,9 cm³/n
- 159 = 5,9 cm³/n 165 = 6,5 cm³/n 178 = 7,5 cm³/n

Group 2 (only SAE-A)

- 204 = 4,2 cm³/n 206 = 6,0 cm³/n 209 = 8,4 cm³/n 211 = 10,8 cm³/n
- 214 = 14,4 cm³/n 217 = 16,8 cm³/n 219 = 19,2 cm³/n 222 = 22,8 cm³/n
- 226 = 26,2 cm³/n 230 = 30,0 cm³/n 240 = 40,0 cm³/n

Group 3 (only SAE-B)

- 315 = 15,0 cm³/n 318 = 18,0 cm³/n 321 = 21,0 cm³/n 327 = 27,0 cm³/n
- 332 = 32,0 cm³/n 338 = 38,0 cm³/n 343 = 43,0 cm³/n 347 = 47,0 cm³/n
- 351 = 51,0 cm³/n 354 = 54,0 cm³/n 361 = 61,0 cm³/n 364 = 64,0 cm³/n
- 370 = 70,0 cm³/n 374 = 74,0 cm³/n 390 = 90,0 cm³/n

12 - Voltage for optionals (where applicable)

- 0 = Without
- 1 = 12V DC
- 2 = 24V DC

(continued)

ORDER CODE _____

3600	TPV	38	CR	SS3	F2	SMIX	OA	20	10	C	000	0	LB	N
0	1	2	3	4	5	6	7	8	9	10	11	12	13	14

Page

13 - Optional		
0	= Without optional	
LB	= Lever by-pass	42
VS	= Purge valve	43
CO (--)	= Pressure cut-off valve (pressure setting)	44
FR	= Pre-arranged for connection with external filter	45
FLT	= Filter without clogging indicator	46
FLTI	= Filter with clogging indicator	47
MOB	= Man on board	48
RS	= Angle sensor	50
REV.S	= RPM Sensor	52
PRS	= Pressure sensor	53
XX	= Restrictor diameter: 05=0,5 - 06=0,6 - 07=0,7 - 08=0,8 - 10=1,0 - 12=1,2	

14 - Port combinations (please contact out technical department)

N/G/U/M = Port threads (N for standard version)

Type combinations	S	A-B	T-T1	P1-P2	Ma-Mb	IN-OUT	G
	Suction port	Main ports	Drain ports	Pilot ports	Pressure gauge ports	External filter ports	Boost gauge port
N (Standard ports)	G6	N6	G5	G2	G2 ²	G4	G2
G¹ (BSPG-Gas ports)	G6	G5	G5	G2	G2 ²	G4	G2
U¹ (UNF-UN ports)	U6	U5	U5	U2	U2 ²	U4	U2
M¹ (UNF+Flanges ports)	U6	N7	U5	U2	U2 ²	U4	U2

Nota¹: on request only, minimum 50 pcs per order
 Nota²: for optional VS, FLT, FLTI and CO are only available G2 ports

SAE flange ports 3/4" SAE 6000	Type	M		N		O		P		Q	
		mm	in	mm	in	mm	in	mm	in	mm	in
	N6	19	0,75	50,8	2,0	M10	50	20	0,79	23,8	0,94

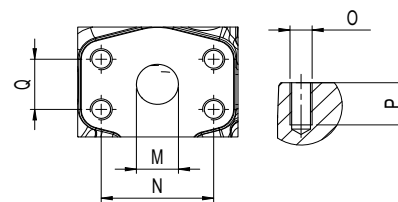

	Type	M	
		Dim.	Assembly torque Nm
ISO 1179-1 ports for BSPG thread	G1	1/8"-28	25
	G2	1/4"-19	40
	G4	1/2"-14	100
	G5	3/4"-14	190
	G6	1"-11	320

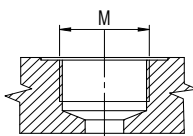

	Type	N	
		Dim.	Assembly torque Nm
ISO 11926-1 ports for UNF-UN thread	U1	7/16-20	21
	U2	9/16-18	40
	U4	7/8-14	100
	U5	1"1/16-12	180
	U6	1"5/16-12	285

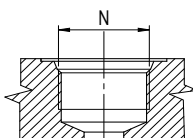

GENERAL DIMENSIONS PUMP

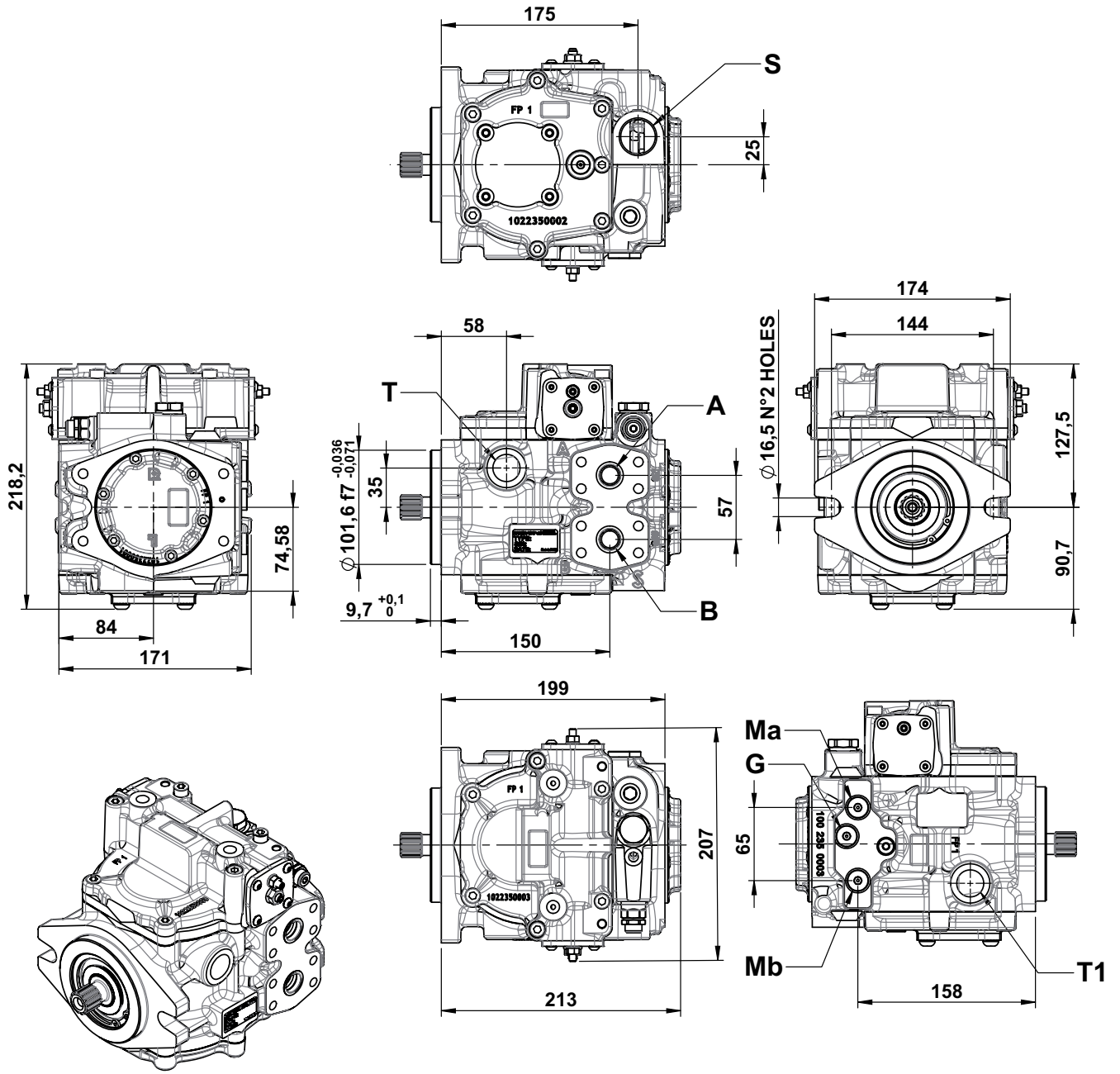

HYDRAULIC CONNECTIONS STANDARD COMBINATION "N"			
PORT	FUNCTION	TYPE	
A-B	Main pressure ports	Flange	3/4" SAE 6000
T-T1	Drain	Thread	3/4" BSPP
S	Suction	Thread	1" BSPP
G	Boost pressure gauge	Thread	1/4" BSPP
Ma-Mb	Pressure gauge ports	Thread	1/4" BSPP

SHAFT OPTIONS AND MOUNTING FLANGES

SS3

SPLINED SHAFT 13T

Norm SAE-B ANSI B92.2-1970 CLASS 5

Max. torque = 320Nm

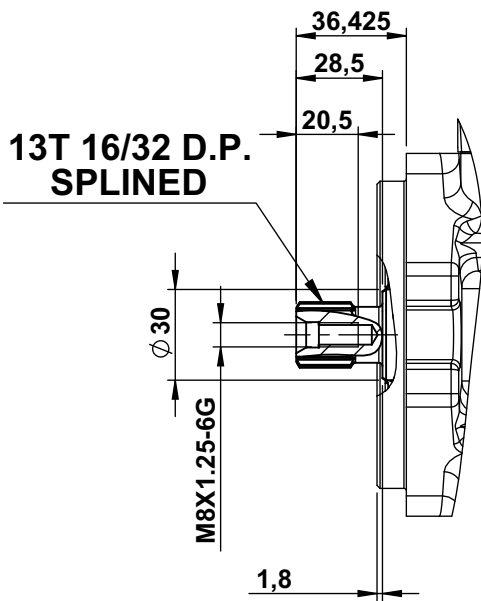

SS5

SPLINED SHAFT SAE-BB Z = 15

Max. torque = 450 Nm

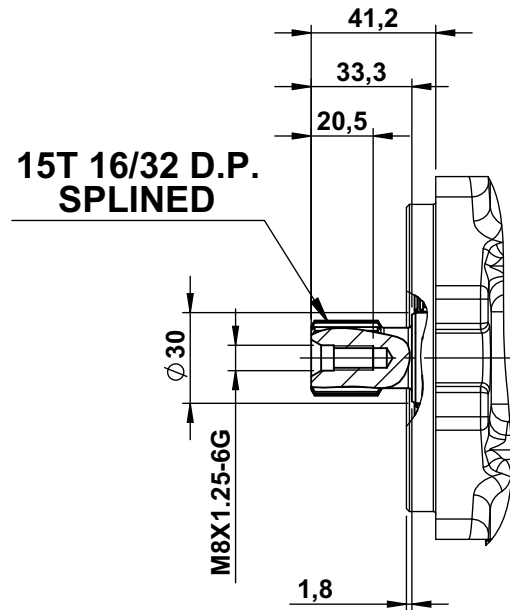

Caution: in case of multiple pump applications the total torque requested must be limited to the above value.

F2

FLANGE SAE B - 2 BOLT

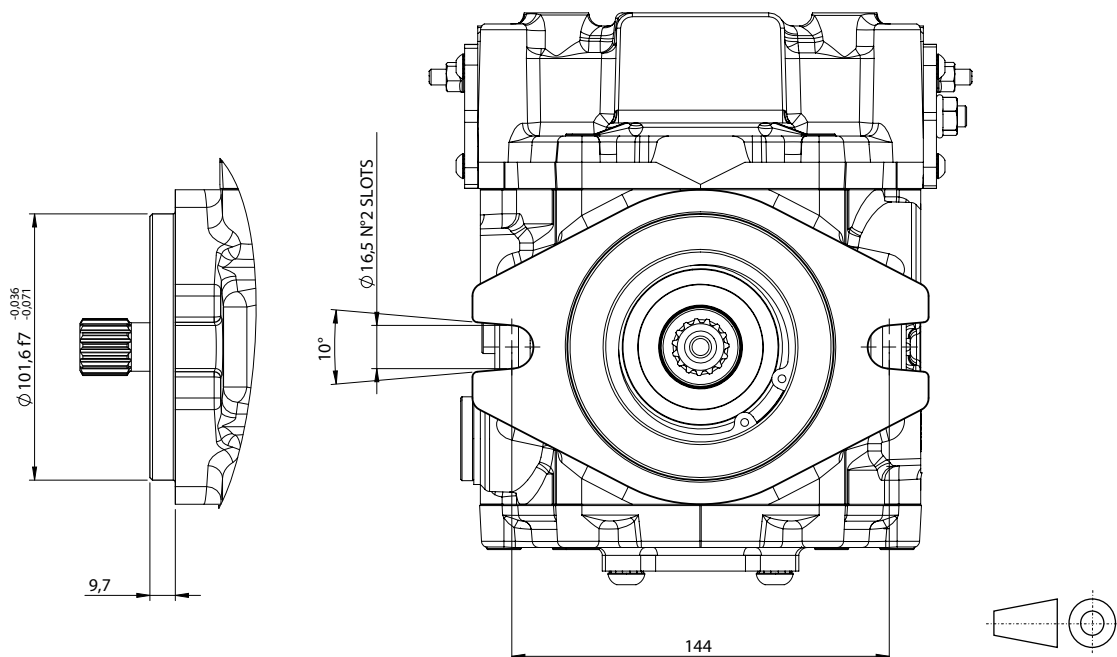

SHI

HYDRAULIC SERVO CONTROL

The pump displacement variation is obtained by adjusting the pressure on P1 and P2 servo control ports by means of a hydraulic proportional joystick (with integrated pressure reducing valves).

The servo control oil supply can be obtained by taking pressure from the boost pump (G port), see page 19.

The servo control return time can be adjusted by inserting a restrictor on the joystick supply

line (0,5 ÷ 1,2 mm).

The servo control operation curve, in both directions, goes from 0,4 to 1,8 MPa (tolerance $\pm 5\%$).

The adjusting curve of the hydraulic joystick has to be a little wider (0,3 ÷ 1,9 MPa).

Suggested curves for HPV series Joysticks: CR062 (see HT 73/B/105/0417/E catalogue).

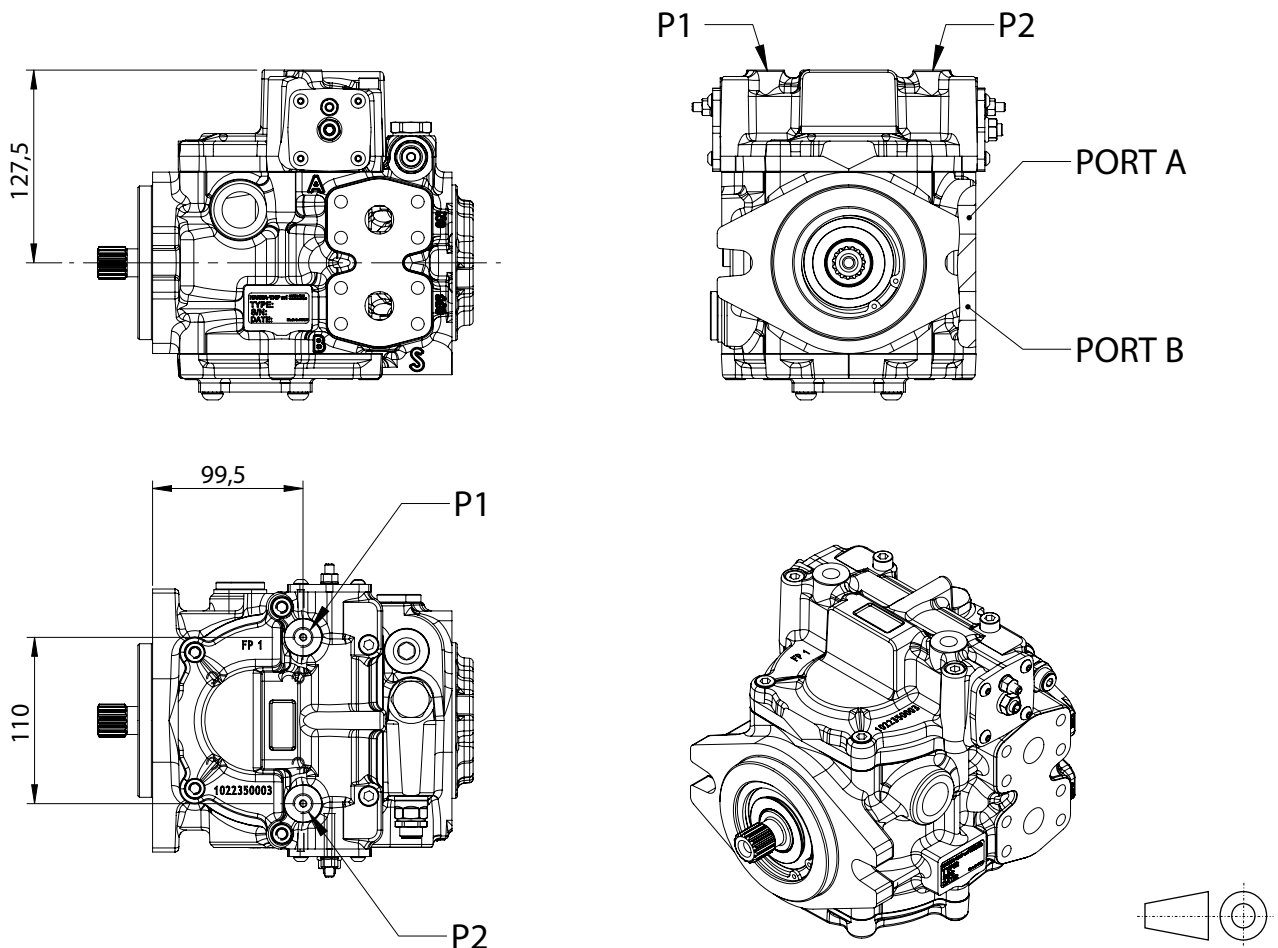

Type combinations	S	A-B	T-T1	P1-P2	Ma-Mb	IN-OUT	G
	Suction port	Main ports	Drain ports	Pilot ports	Pressure gauge ports	External filter ports	Boost gauge port
N (Standard ports)	G6	N6	G5	G2	G2 ²	G4	G2
G¹ (BSPP-Gas ports)	G6	G5	G5	G2	G2 ²	G4	G2
U¹ (UNF-UN ports)	U6	U5	U5	U2	U2 ²	U4	U2
M¹ (UNF+Flanges ports)	U6	N7	U5	U2	U2 ²	U4	U2

Nota¹: on request only, minimum 50 pcs per order

Nota²: for optional VS, FLT, FLT1 and CO are only available G2 ports

(continued)

SHI

COMPACT HYDRAULIC SERVO CONTROL

HYDRAULIC DIAGRAM

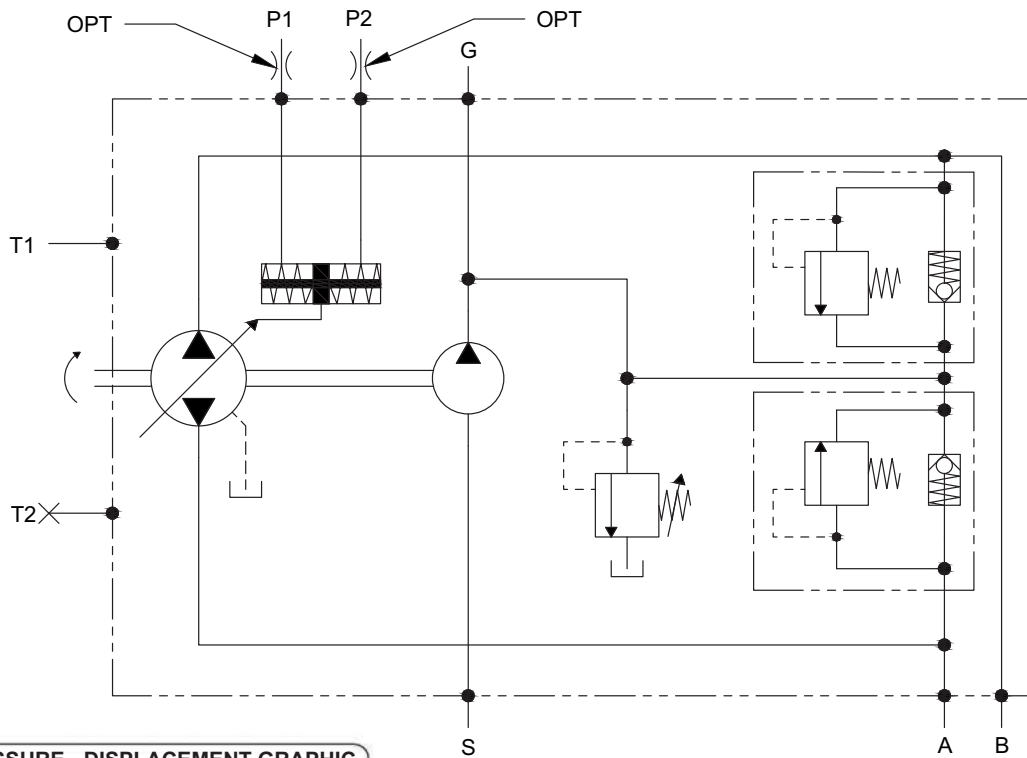

SERVO PRESSURE - DISPLACEMENT GRAPHIC

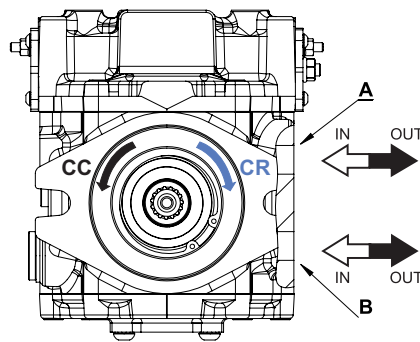
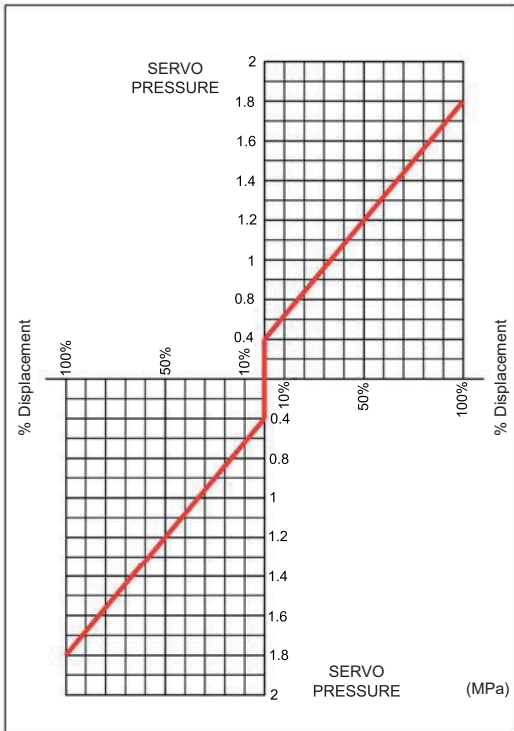

FLOW DIRECTION	PUMP		
	Port	OUT	IN
Rotation			
Clockwise (CR)	P ₁ P ₂	B A	A B
Counter clockwise (CC)	P ₁ P ₂	A B	B A

SEI 1.3 (12V DC)

SEI 2.3 (24V DC)

ELECTRO-PROPORTIONAL SERVO CONTROL

(AMP junior timer connector)

The pump displacement variation is obtained by an electric signal, which varies approx.:

- from 315 to 630 mA (24V DC voltage)
- from 630 to 1260 mA (12V DC voltage)

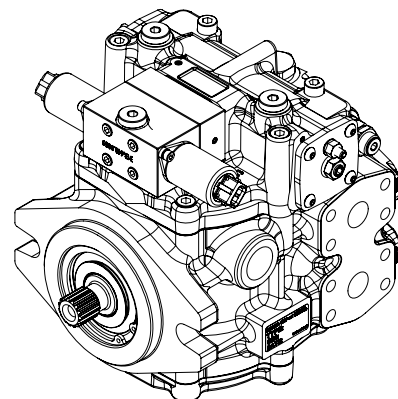
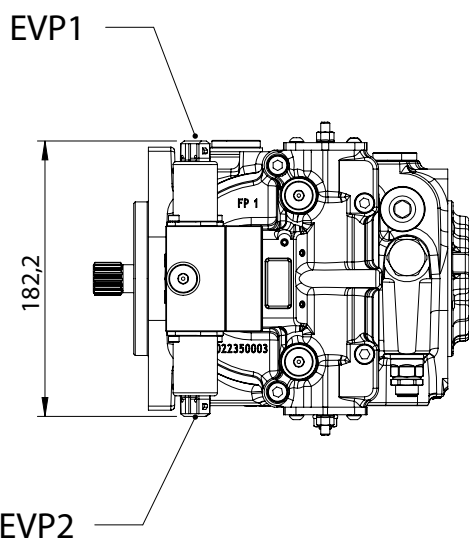
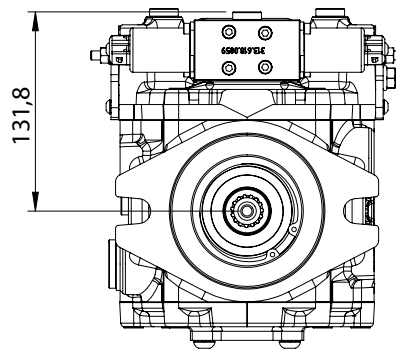
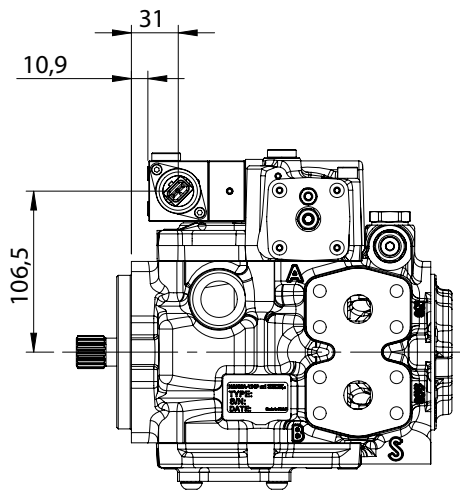

(continued)

SEI 1.3 (12V DC)

SEI 2.3 (24V DC)

ELECTRO-PROPORTIONAL SERVO CONTROL

(AMP junior timer connector)

HYDRAULIC DIAGRAM

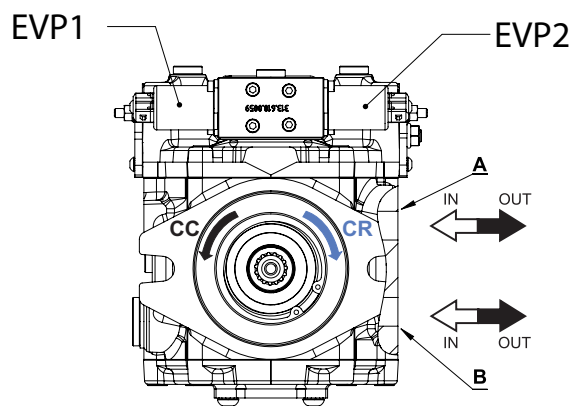
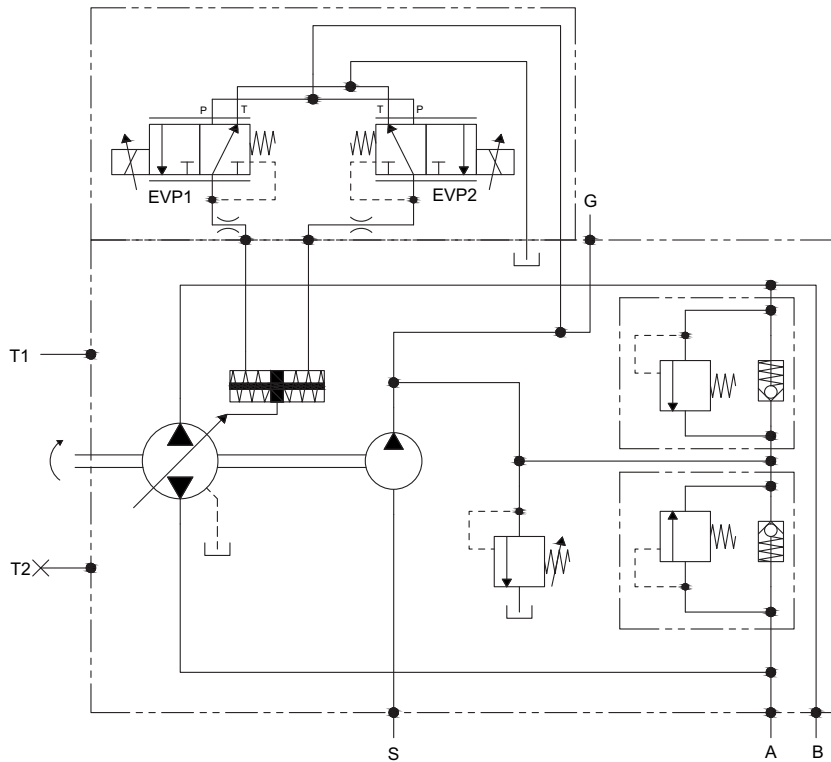

FLOW DIRECTION	PUMP		
Rotation	EVP	OUT	IN
Clockwise (CR)	EVP1 EVP2	B A	A B
Counter clockwise (CC)	EVP1 EVP2	A B	B A

(continued)

SEI 1.3 (12V DC)

SEI 2.3 (24V DC)

ELECTRO-PROPORTIONAL SERVO CONTROL

(AMP junior timer connector)

CURRENT-DISPLACEMENT GRAPHIC

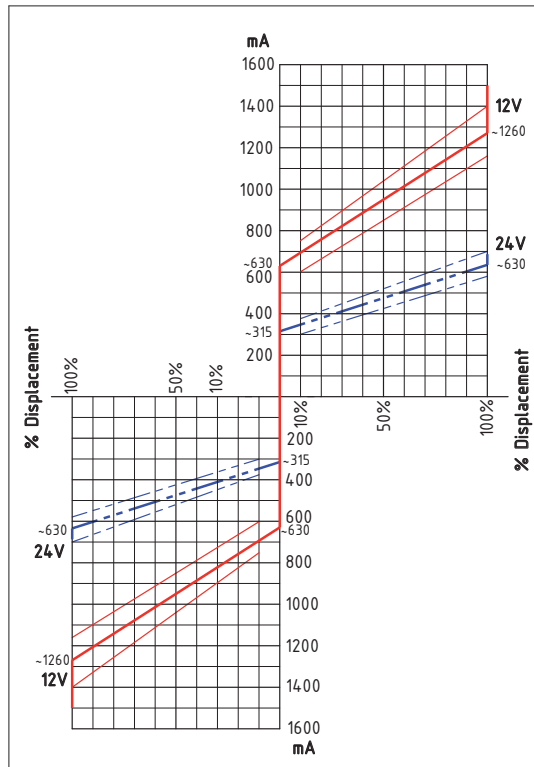

ELECTRICAL FEATURES		
Voltage	12 V DC	24 V DC
Electric current	1500 mA	750 mA
Load resistance	4,72 Ω ± 5%	20,8 Ω ± 5%
Type of control	Current control	
	PWM 100 Hz (suggested)	
Type of connection	AMP Junior Timer	
Protection class	Until IP6K6 / IPX9K	

HYDRAULIC FEATURES	
Max. pressure (P, T)	pP= 5 MPa, pT= 3 MPa
Hysteresis (w/PWM)	<0,07 MPa (pA=2,0)
	<0,1 MPa (pA=2,5)
	<0,15 MPa (pA=3,5)
Filtration ratio	125 µm
Oil contamination level	Min. filtration ratio: 20/18/15
	According ISO 4406
	Hydraulic oil DIN 51524
Min./max. oil temperature	From -20 to +90°C

SEI 1.3D (12V DC)

SEI 2.3D (24V DC)

ELECTRO-PROPORTIONAL SERVO CONTROL

(Deutsch connector)

The pump displacement variation is obtained by an electric signal, which varies approx.:

- from 315 to 630 mA (24V DC voltage)
- from 630 to 1260 mA (12V DC voltage)

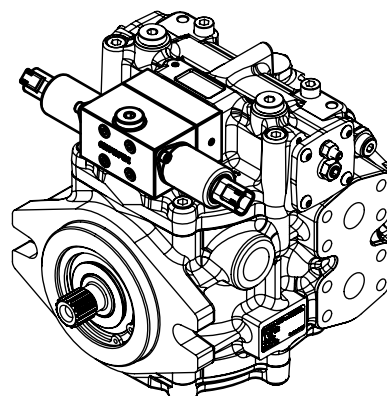
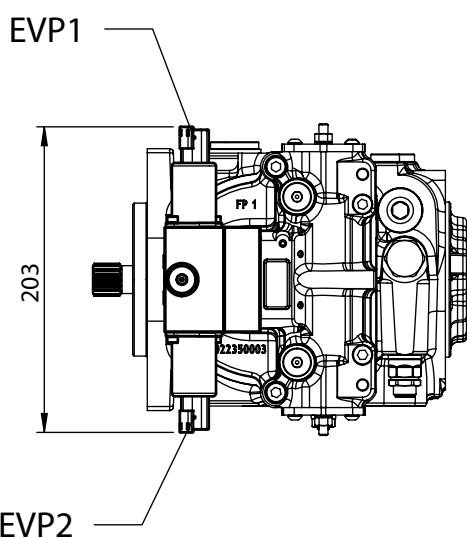
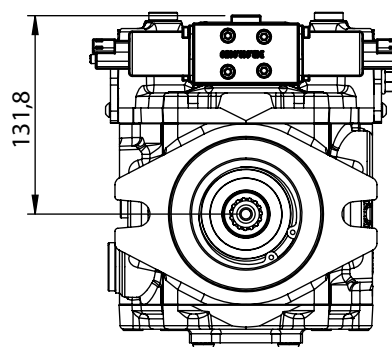
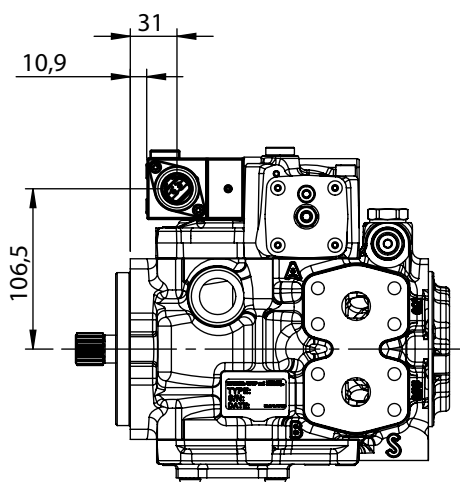

(continued)

SEI 1.3D (12V DC)

SEI 2.3D (24V DC)

ELECTRO-PROPORTIONAL SERVO CONTROL

(Deutsch connector)

HYDRAULIC DIAGRAM

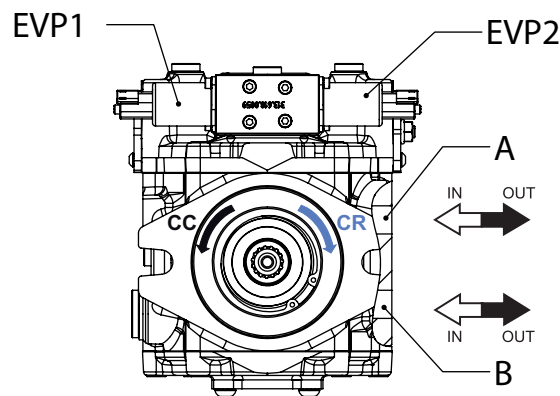
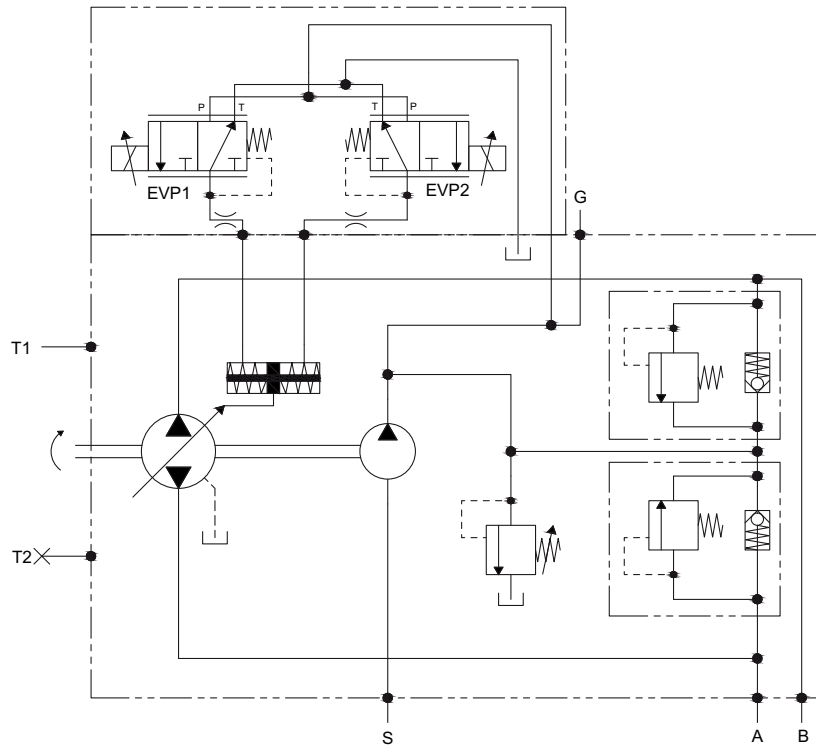

FLOW DIRECTION	PUMP		
Rotation	EVP	OUT	IN
Clockwise (CR)	EVP1 EVP2	B A	A B
Counter clockwise (CC)	EVP1 EVP2	A B	B A

(continued)

SEI 1.3D (12V DC)

SEI 2.3D (24V DC)

ELECTRO-PROPORTIONAL SERVO CONTROL

(Deutsch connector)

CURRENT-DISPLACEMENT GRAPHIC

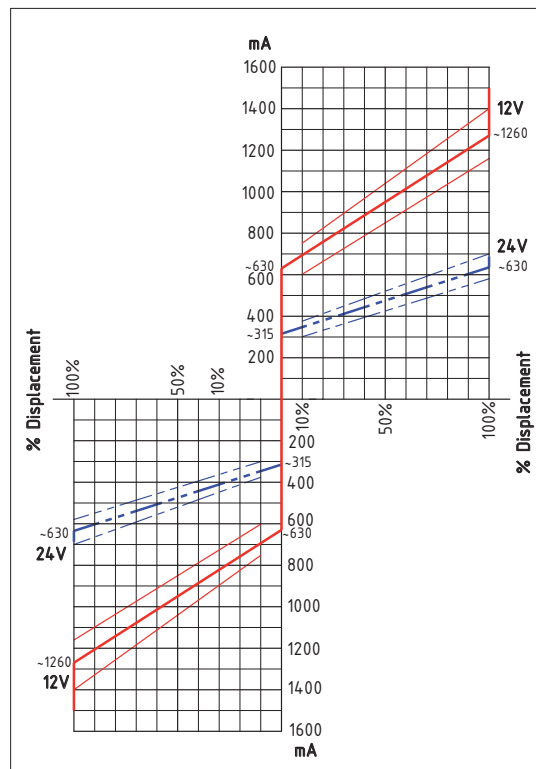

ELECTRICAL FEATURES		
Voltage	12 V DC	24 V DC
Electric current	1500 mA	750 mA
Load resistance	4,72 Ω ± 5%	20,8 Ω ± 5%
Type of control	Current control	
	PWM 100 Hz (suggested)	
Type of connection	AMP Junior Timer	
Protection class	Until IP6K6 / IPX9K	

HYDRAULIC FEATURES	
Max. pressure (P, T)	pP= 5 MPa, pT= 3 MPa
Hysteresis (w/PWM)	<0,07 MPa (pA=2,0)
	<0,1 MPa (pA=2,5)
	<0,15 MPa (pA=3,5)
Filtration ratio	125 μm
Oil contamination level	Min. filtration ratio: 20/18/15
	According ISO 4406
	Hydraulic oil DIN 51524
Min./max. oil temperature	From -20 to +90°C

SHIX

HYDRAULIC SERVO CONTROL WITH FEED BACK

The pump displacement variation is obtained by adjusting the pressure on P1 and P2 servo control ports by means of a hydraulic proportional joystick (with integrated pressure reducing valves).

The servo control oil supply can be obtained by taking pressure from the boost pump (G port), see page 19.

The servo control return time can be adjusted by inserting a restrictor on the joystick supply line (0,5 ÷ 1,2 mm).

The servo control operation curve, in both directions, goes from 0,4 to 2 MPa (tolerance $\pm 5\%$).

The adjusting curve of the hydraulic joystick has to be a little wider (0,3 ÷ 2,1 MPa).

Suggested curves for HPV series Joysticks: CR096 (see HT 73/B/105/0417/E catalogue).

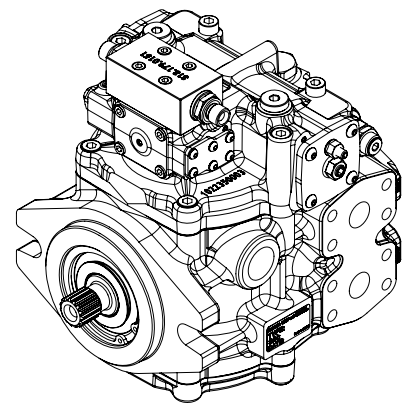
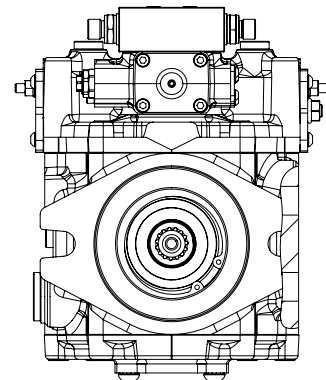
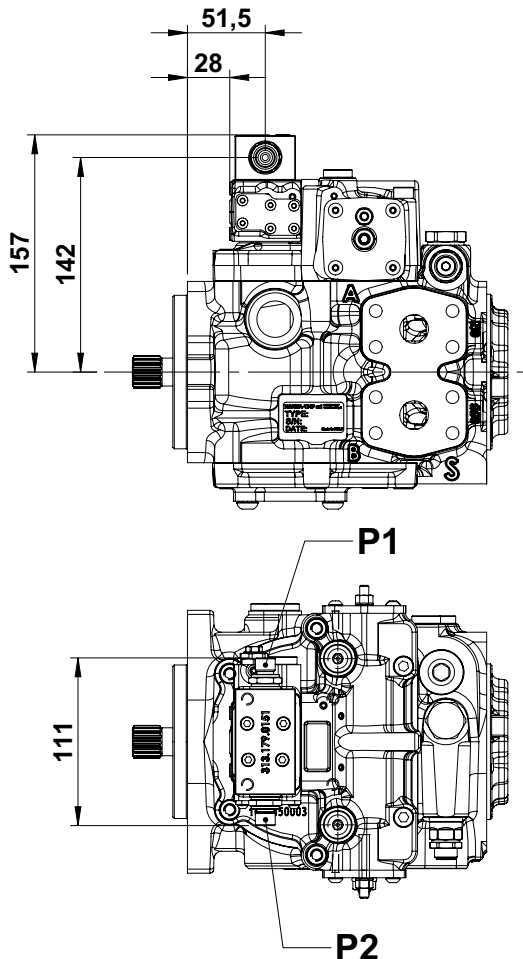

Type combinations	S	A-B	T-T1	P1-P2	Ma-Mb	IN-OUT	G
	Suction port	Main ports	Drain ports	Pilot ports	Pressure gauge ports	External filter ports	Boost gauge port
N (Standard ports)	G6	N6	G5	G2	G2 ²	G4	G2
G ¹ (BSPP-Gas ports)	G6	G5	G5	G2	G2 ²	G4	G2
U ¹ (UNF-UN ports)	U6	U5	U5	U2	U2 ²	U4	U2
M ¹ (UNF+Flanges ports)	U6	N7	U5	U2	U2 ²	U4	U2

Nota¹: on request only, minimum 50 pcs per order

Nota²: for optional VS, FLT, FLT1 and CO are only available G2 ports

(continued)

SHIX

HYDRAULIC SERVO CONTROL WITH FEED BACK

HYDRAULIC DIAGRAM

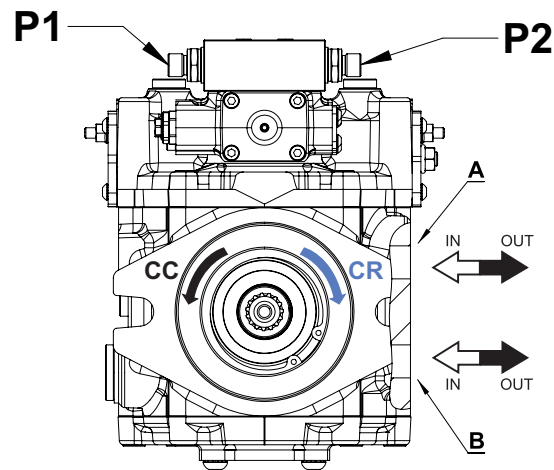
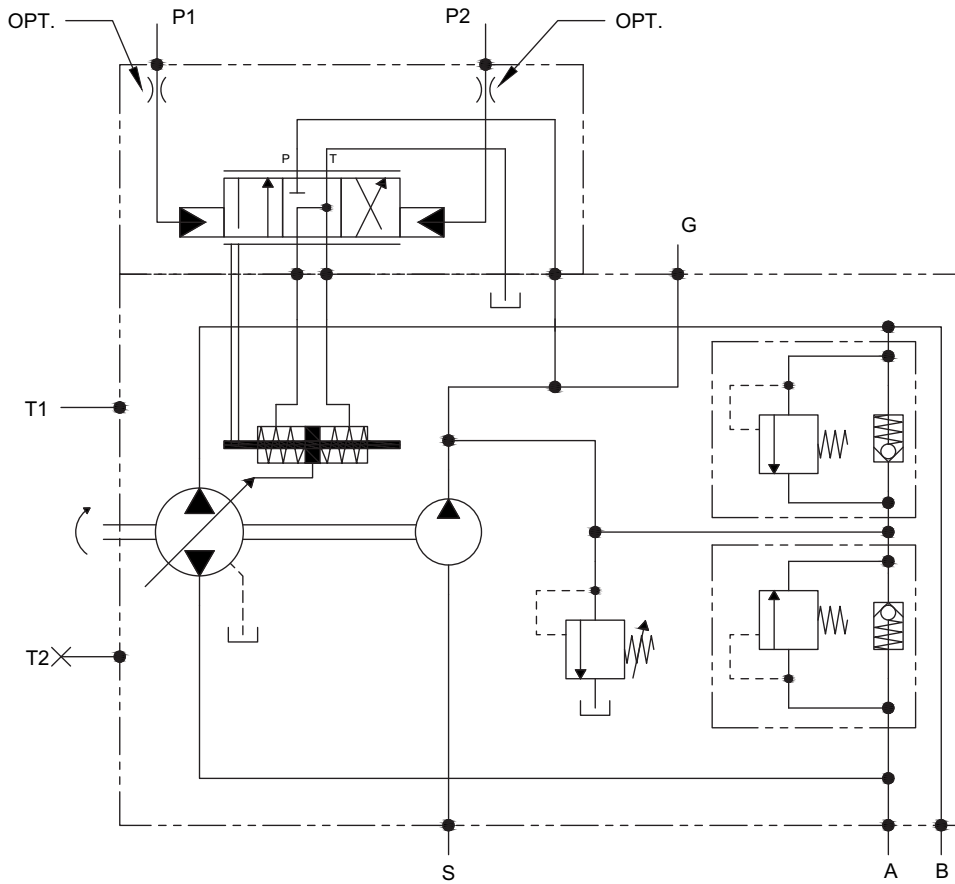

FLOW DIRECTION	PUMP		
	Port	OUT	IN
Clockwise (CR)	P ₁	A	B
	P ₂	B	A
Counter clockwise (CC)	P ₁	B	A
	P ₂	A	B

SMIX

MANUAL LEVER CONTROL WITH FEED BACK

The pump displacement variation is directly related to the angle position of the lever.

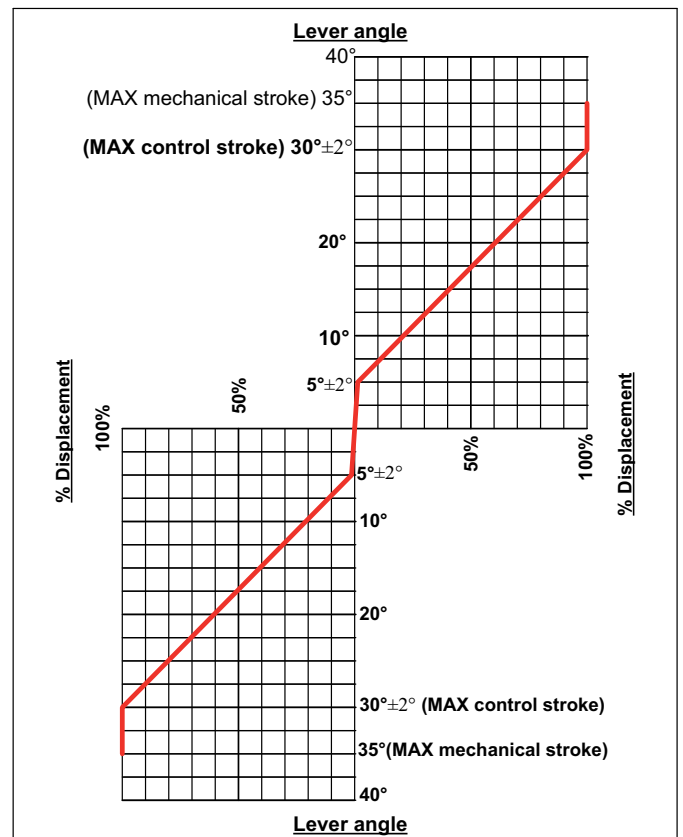
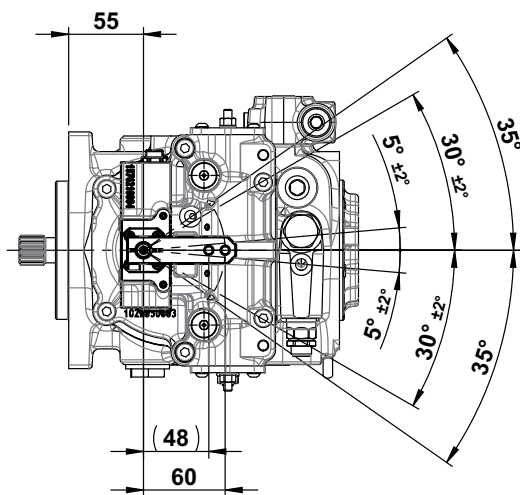
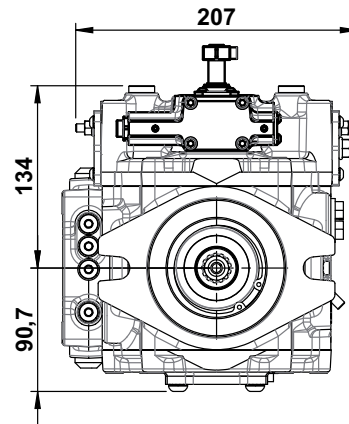
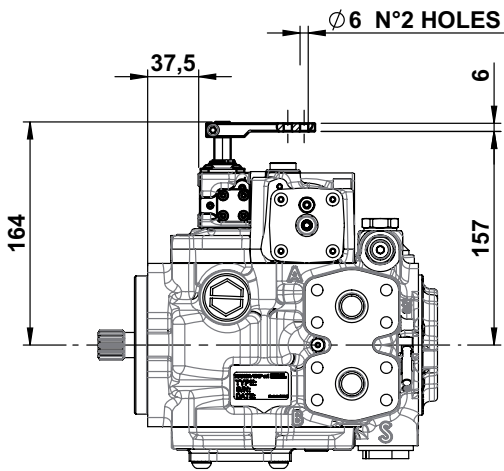
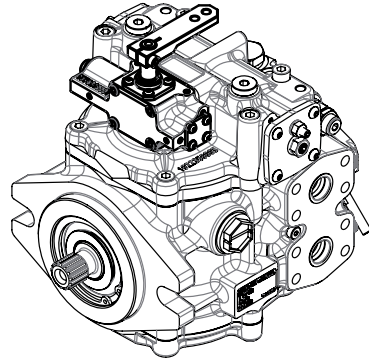

(continued)

SMIX

MANUAL LEVER CONTROL WITH FEED BACK

HYDRAULIC DIAGRAM

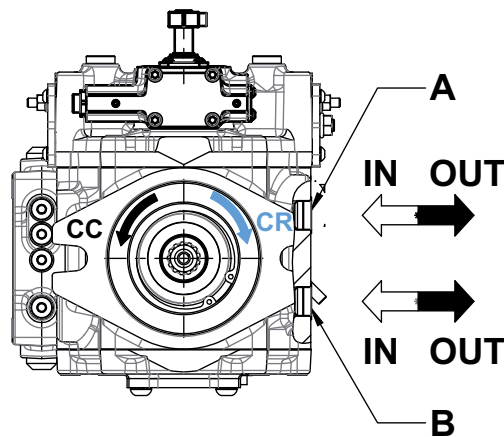
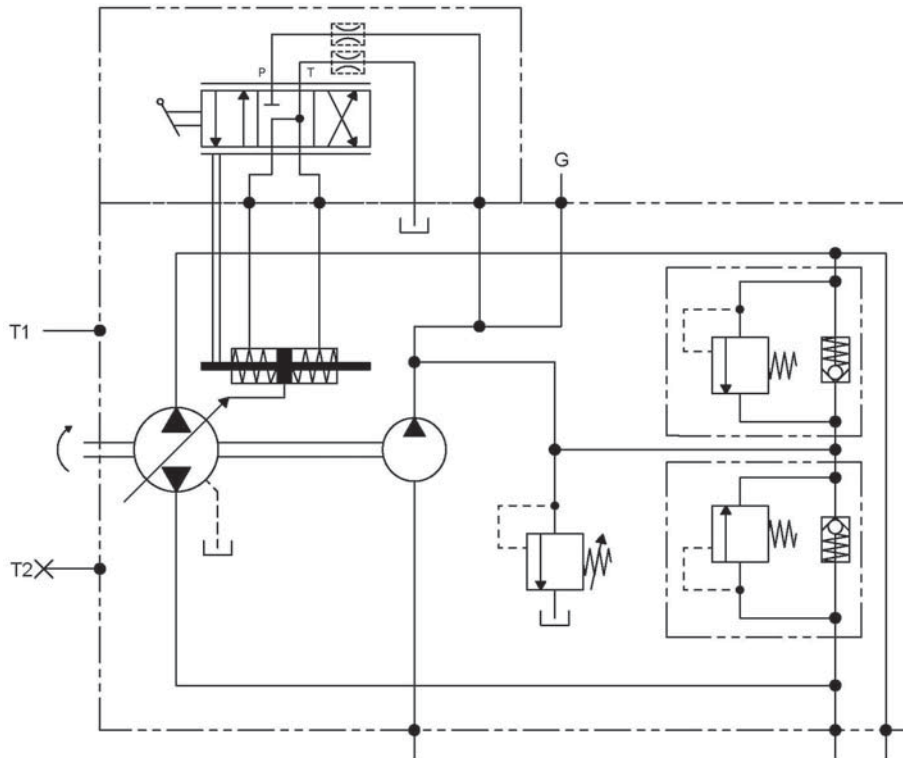

FLOW DIRECTION	PUMP		
Rotation	Lever direction	OUT	IN
Clockwise (CR)	a	B	A
	b	A	B
Counter clockwise (CC)	a	A	B
	b	B	A

SEIX 1.3 (12V DC)
SEIX 2.3 (24V DC)

ELECTRO-PROPORTIONAL SERVO CONTROL WITH FEED BACK

(AMP junior timer connector)

The pump displacement variation is obtained by an electric signal, which varies approx.:

- from 315 to 630 mA (24V DC voltage)
- from 630 to 1260 mA (12V DC voltage)

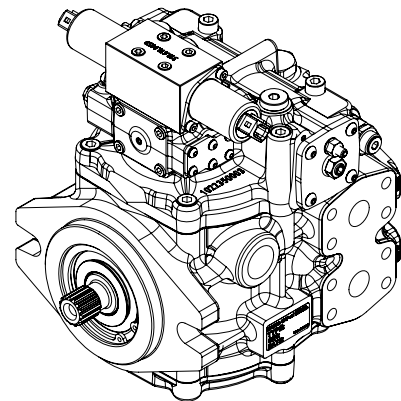
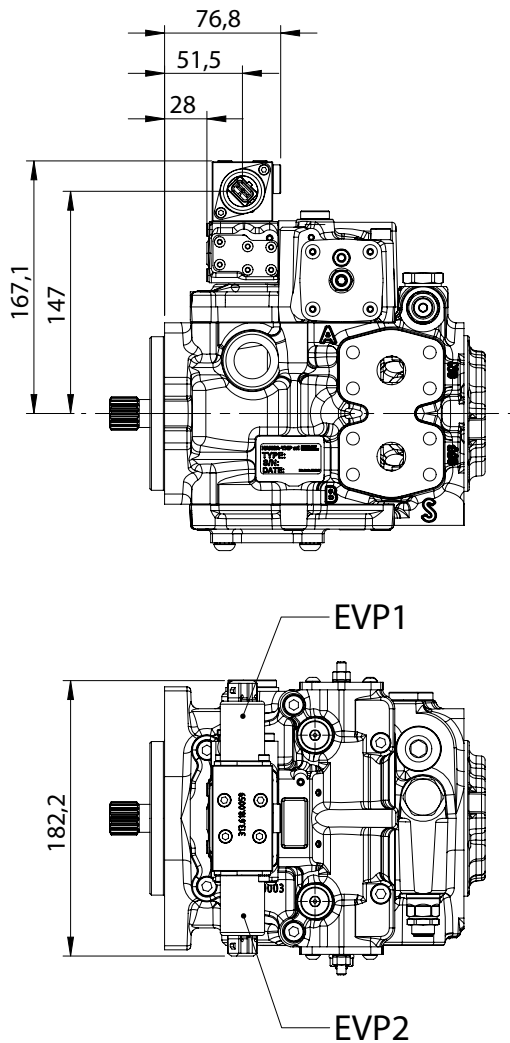

(continued)

SEIX 1.3 (12V DC)

SEIX 2.3 (24V DC)

ELECTRO-PROPORTIONAL SERVO CONTROL WITH FEED BACK

(AMP junior timer connector)

HYDRAULIC DIAGRAM

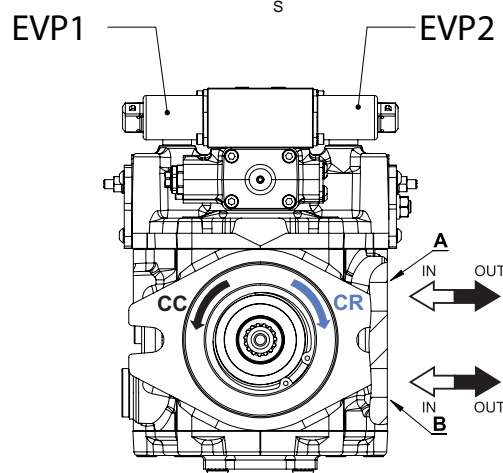
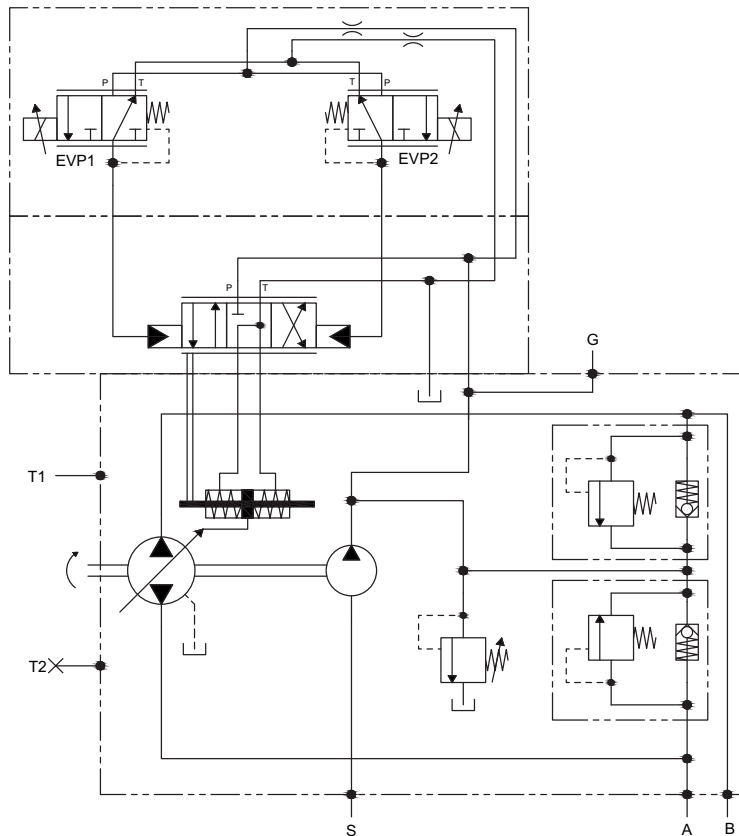

FLOW DIRECTION	PUMP		
Rotation	EVP	OUT	IN
Clockwise (CR)	EVP1 EVP2	A B	B A
Counter clockwise (CC)	EVP1 EVP2	B A	A B

(continued)

SEIX 1.3 (12V DC)

SEIX 2.3 (24V DC)

ELECTRO-PROPORTIONAL SERVO CONTROL WITH FEED BACK

(AMP junior timer connector)

CURRENT-DISPLACEMENT GRAPHIC

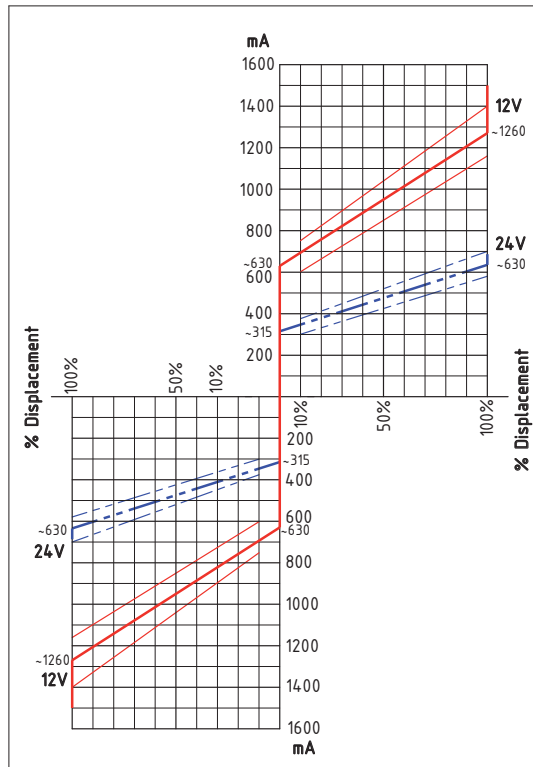

ELECTRICAL FEATURES		
Voltage	12 V DC	24 V DC
Electric current	1500 mA	750 mA
Load resistance	4,72 Ω ± 5%	20,8 Ω ± 5%
Type of control	Current control	
	PWM 100 Hz (suggested)	
Type of connection	AMP Junior Timer	
Protection class	Until IP6K6 / IPX9K	

HYDRAULIC FEATURES	
Max. pressure (P, T)	pP= 5 MPa, pT= 3 MPa
Hysteresis (w/PWM)	<0,07 MPa (pA=2,0)
	<0,1 MPa (pA=2,5)
	<0,15 MPa (pA=3,5)
Filtration ratio	125 µm
Oil contamination level	Min. filtration ratio: 20/18/15
	According ISO 4406
	Hydraulic oil DIN 51524
Min./max. oil temperature	From -20 to +90°C

SEIX 1.3D (12V DC)

SEIX 2.3D (24V DC)

ELECTRO-PROPORTIONAL SERVO CONTROL WITH FEED BACK

(Deutsch connector)

The pump displacement variation is obtained by an electric signal, which varies approx.:

- from 315 to 630 mA (24V DC voltage)
- from 630 to 1260 mA (12V DC voltage)

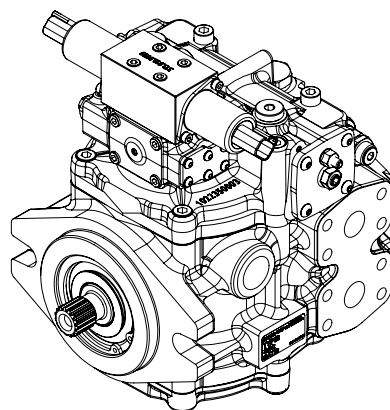
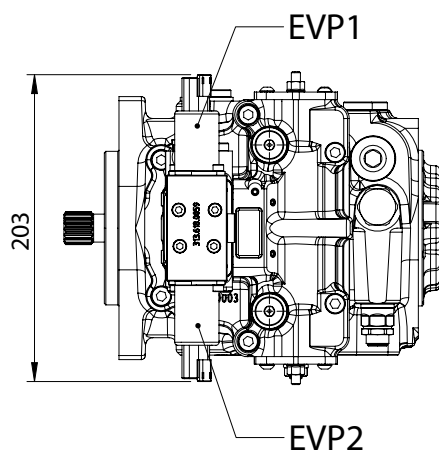
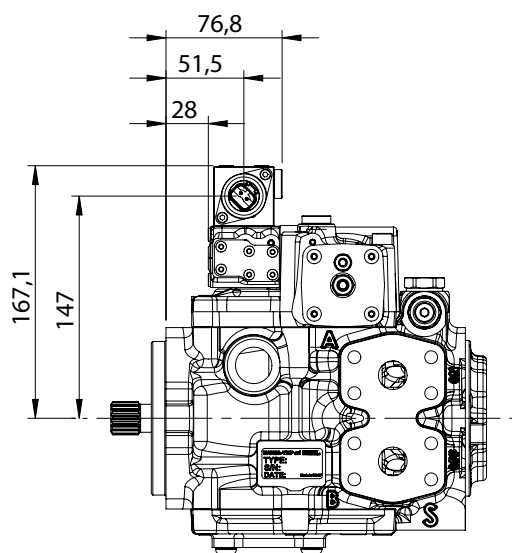

(continued)

SEIX 1.3D (12V DC)

SEIX 2.3D (24V DC)

ELECTRO-PROPORTIONAL SERVO CONTROL WITH FEED BACK

(Deutsch connector)

HYDRAULIC DIAGRAM

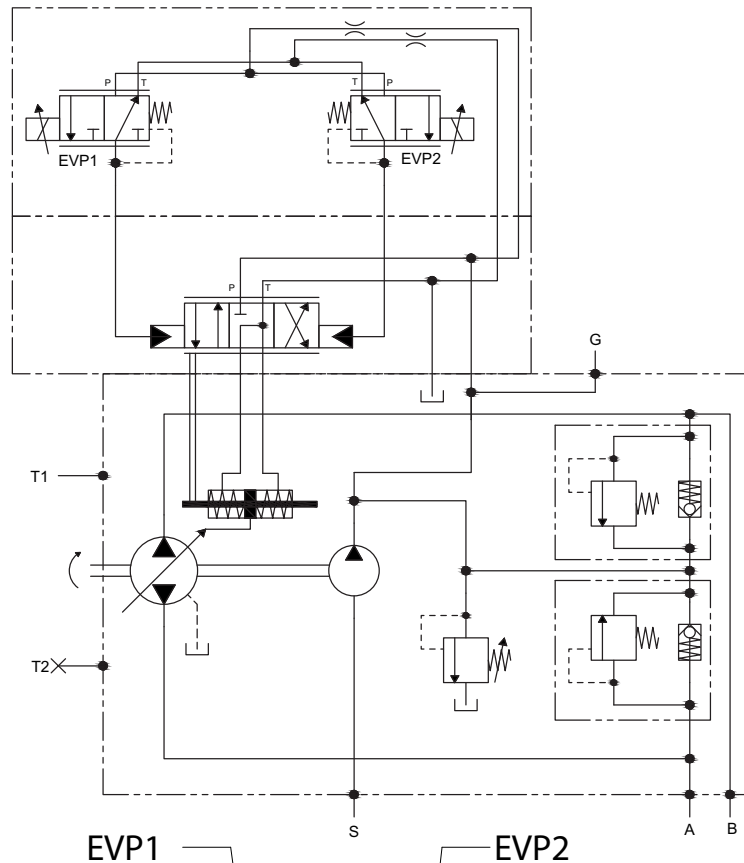

EVP1 EVP2

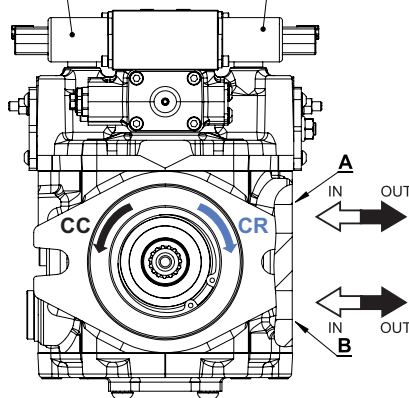

FLOW DIRECTION	PUMP		
Rotation	 EVP	OUT	IN
Clockwise (CR)	EVP1 EVP2	A B	B A
Counter clockwise (CC)	EVP1 EVP2	B A	A B

(continued)

SEIX 1.3D (12V DC)
SEIX 2.3D (24V DC)

ELECTRO-PROPORTIONAL SERVO CONTROL WITH FEED BACK

(Deutsch connector)

CURRENT-DISPLACEMENT GRAPHIC

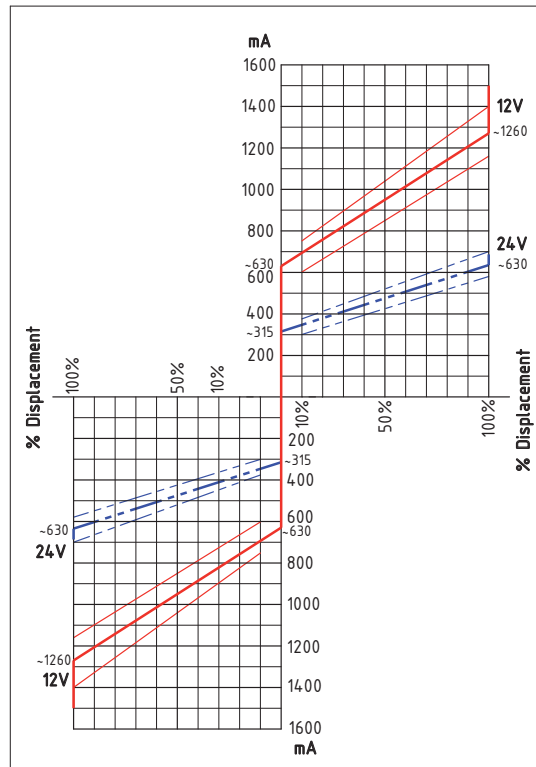

ELECTRICAL FEATURES		
Voltage	12 V DC	24 V DC
Electric current	1500 mA	750 mA
Load resistance	4,72 Ω ± 5%	20,8 Ω ± 5%
Type of control	Current control PWM 100 Hz (suggested)	
Type of connection	DEUTSCH DT 04-2P	
Protection class	Until IP6K6 / IPX9K	

HYDRAULIC FEATURES	
Max. pressure (P, T)	pP= 5 MPa, pT= 3 MPa
Hysteresis (w/PWM)	<0,07 MPa (pA=2,0)
	<0,1 MPa (pA=2,5)
	<0,15 MPa (pA=3,5)
Filtration ratio	125 µm
Oil contamination level	Min. filtration ratio: 20/18/15
	According ISO 4406
	Hydraulic oil DIN 51524
Min./max. oil temperature	From -20 to +90°C

MAIN PORTS POSITION

OA
STANDARD VERSION

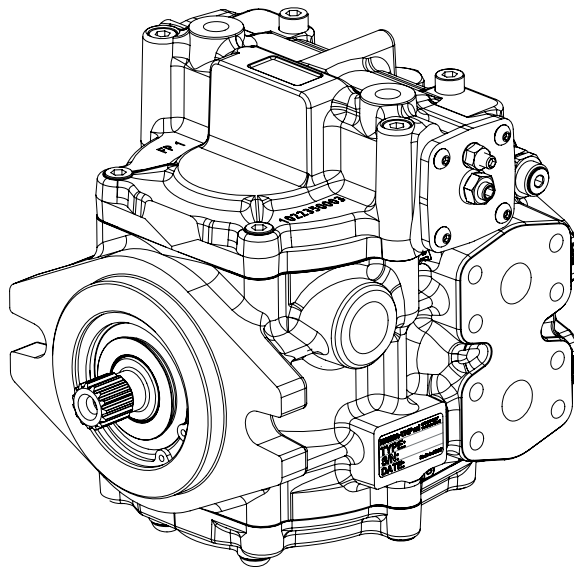

OB
(On request)

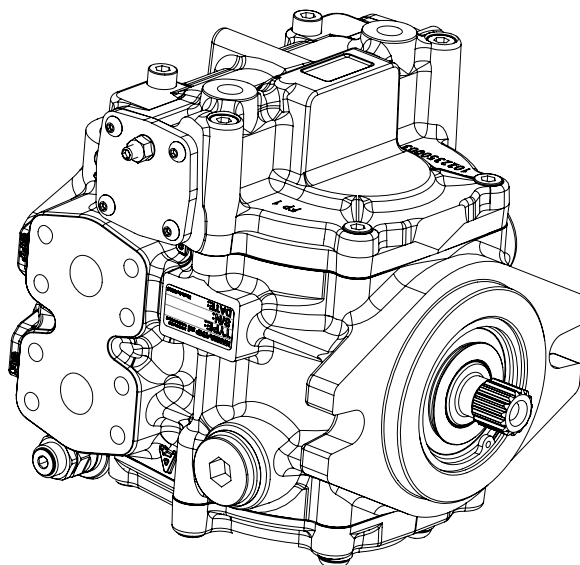

REAR PUMP MOUNTING FLANGES

C
CLOSED (WITHOUT CONNECTION FOR REAR PUMP) - STANDARD VERSION

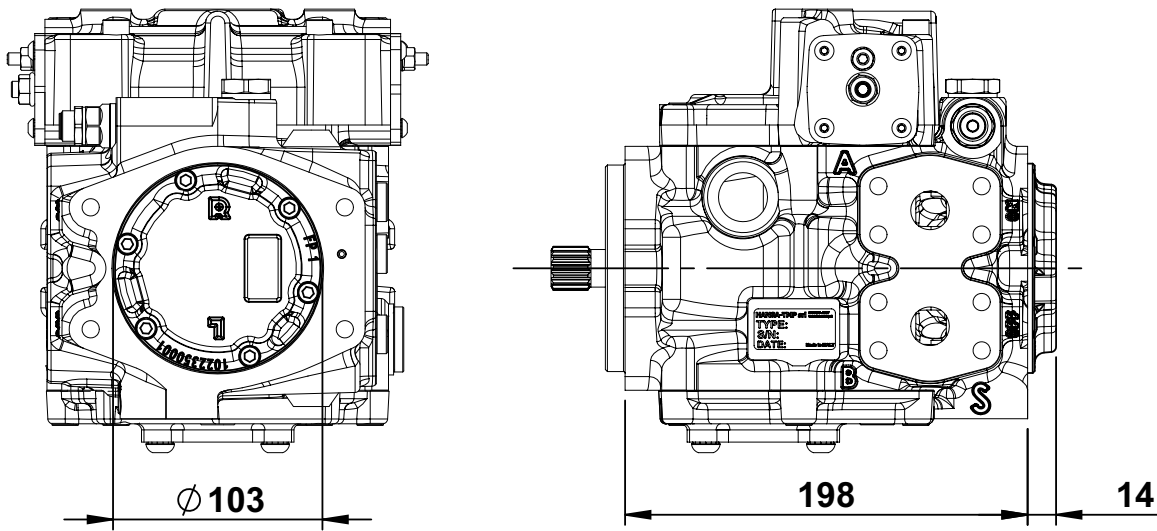

B1
GERMAN STANDARD
Max torque = 70 Nm

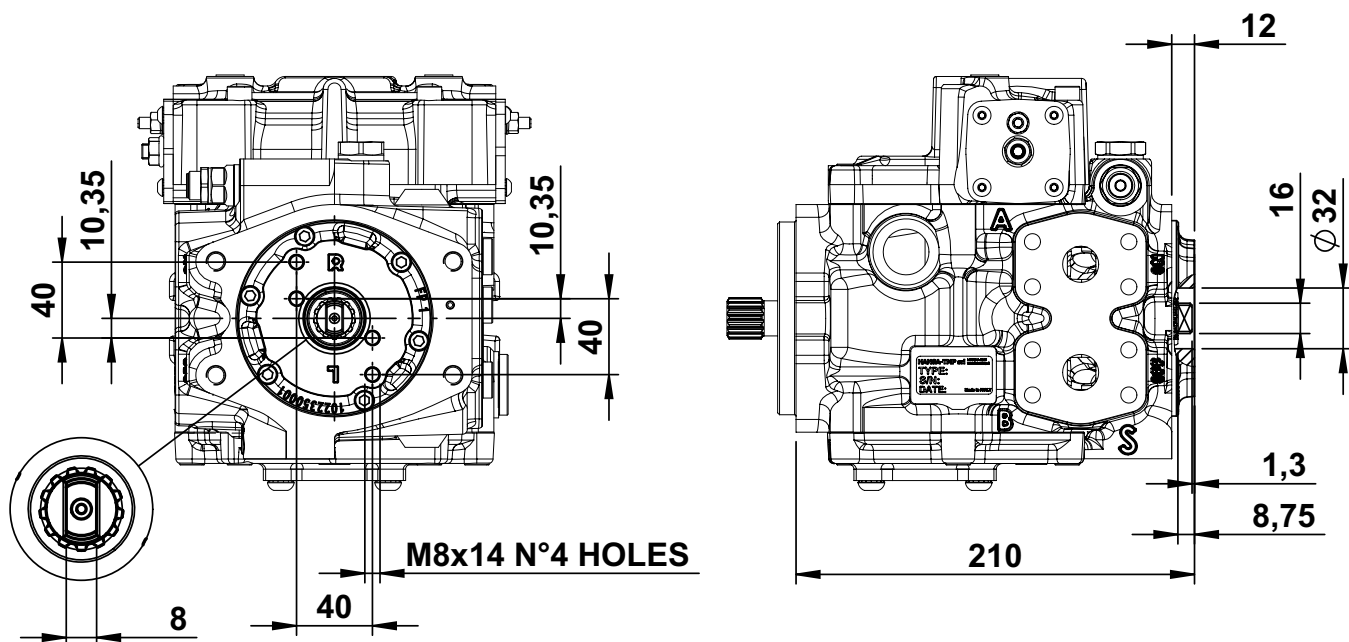

(continued)

REAR PUMP MOUNTING FLANGES

SAE A

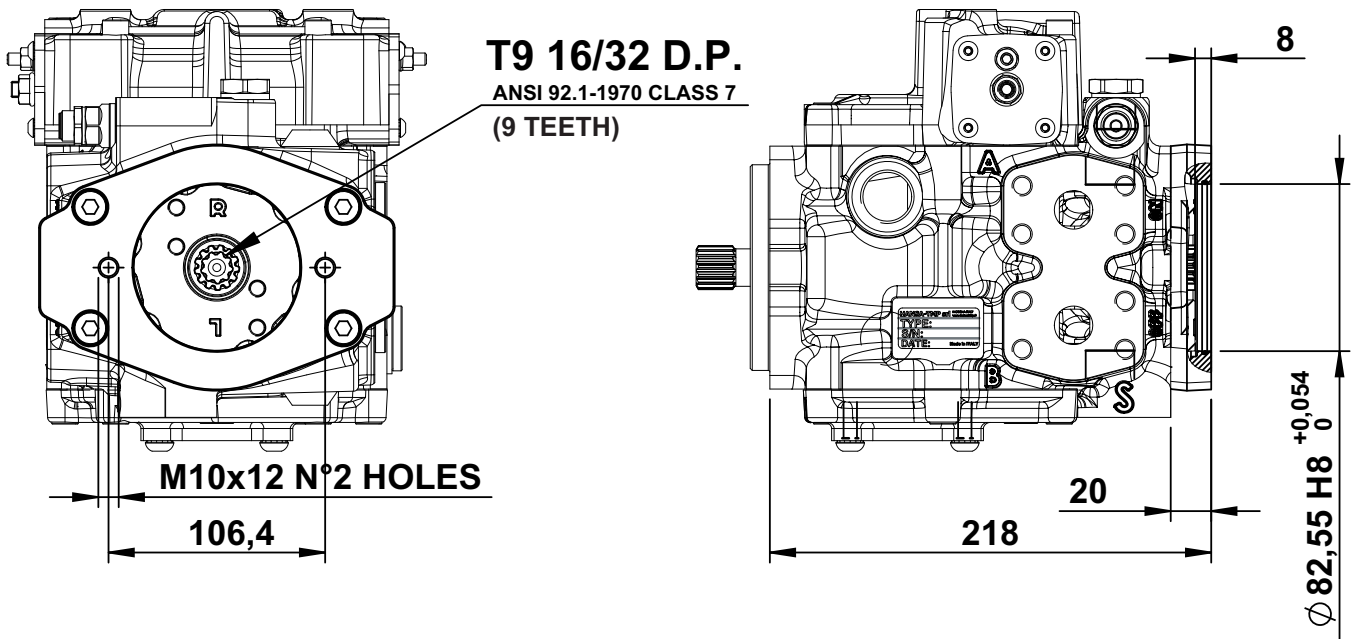

SAE B

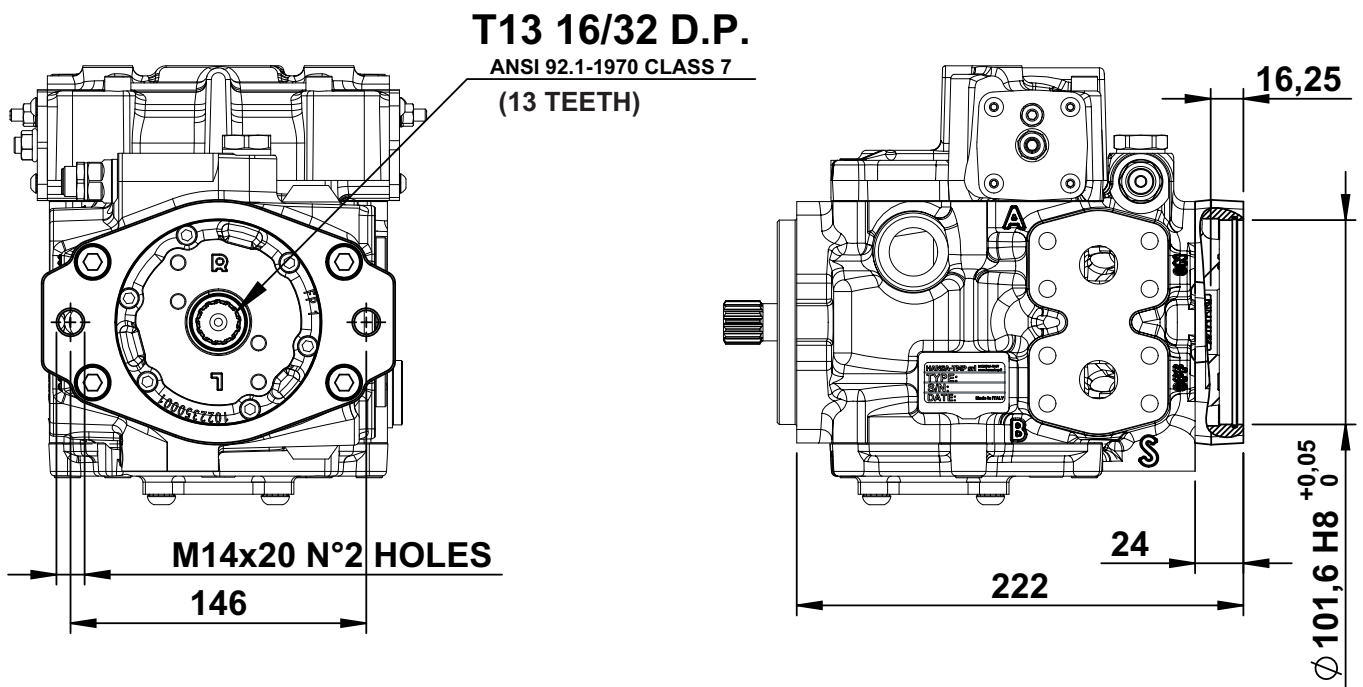

OPTIONAL LB

LEVER BY-PASS

To by pass the oil flow from one direction to the other, with the pump not running or in emergency condition, a by pass lever can be actuated to connect the 2 lines of the hydraulic system.

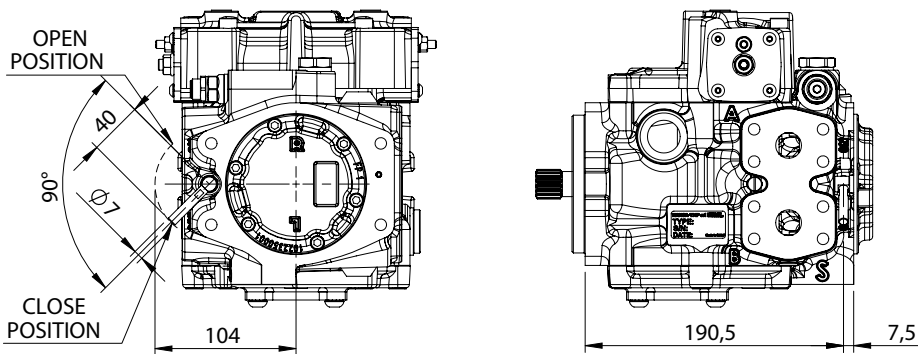
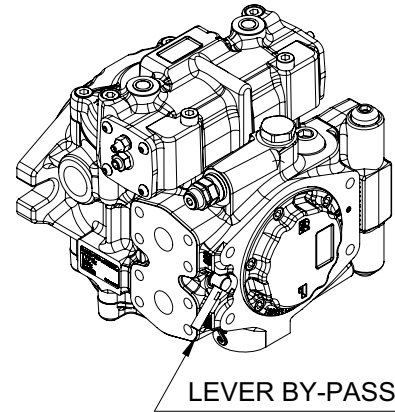

HYDRAULIC DIAGRAM

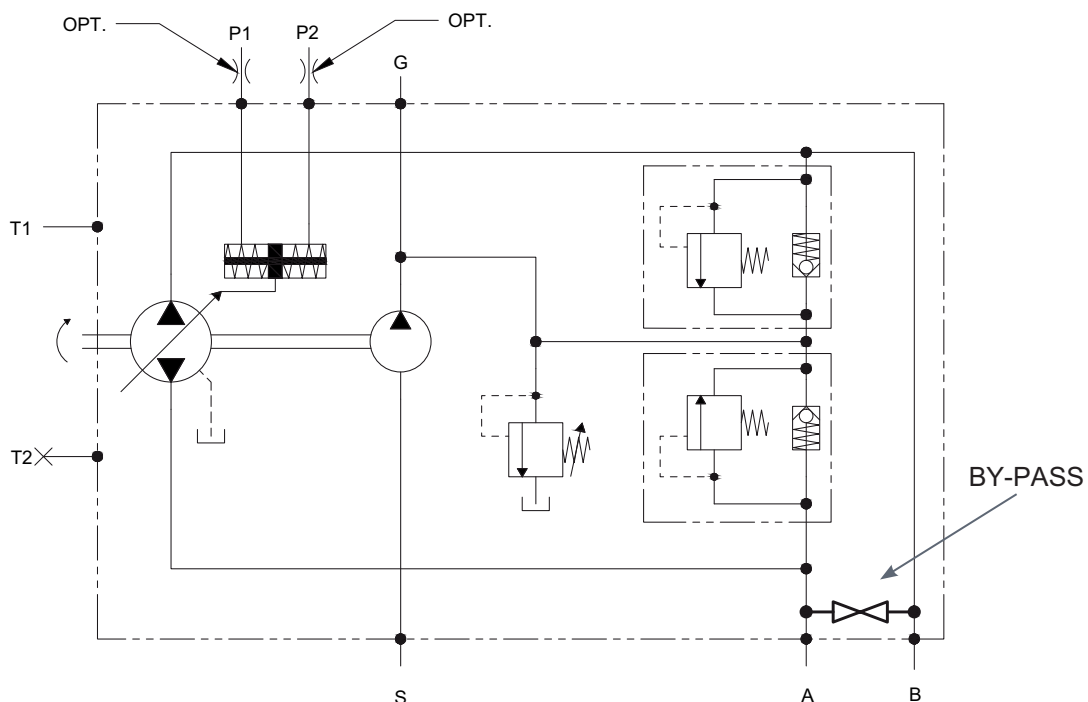

OPTIONAL VS

PURGE VALVE

For the TPV-TPVT 3600 pumps is available an integrated purge valve (loop flushing).

The valve consists of a spring centered shuttle spool connecting automatically the low pressure line (boost) with the reservoir removing heat from the system.

The quantity of the flushing oil is a function of the low system pressure (boost) and the size of the orifice on the valve (different orifices are available referred to the system pressure).

The spool shifts at a differential pressure of about 0,8 MPa (116 PSI).

PURGE VALVE

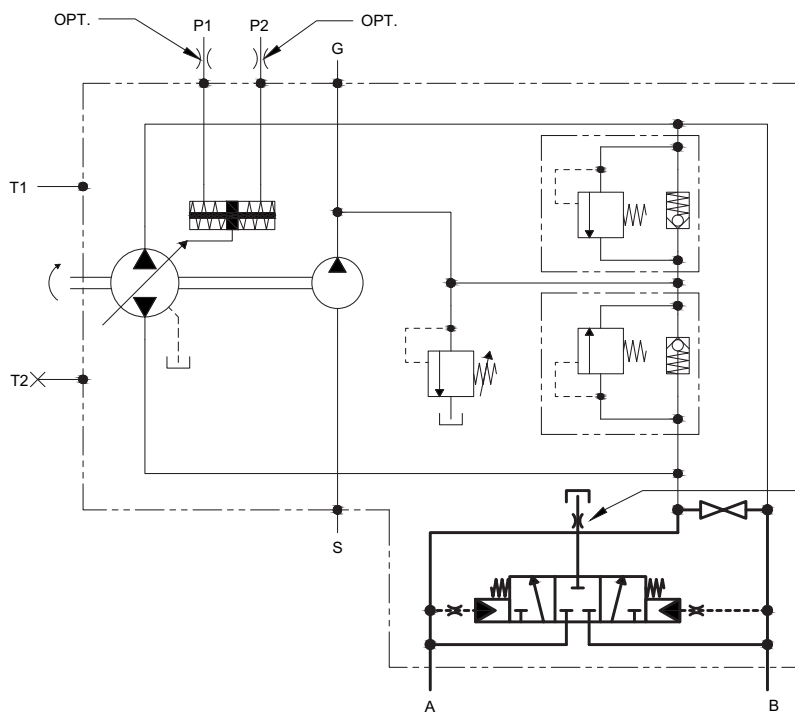
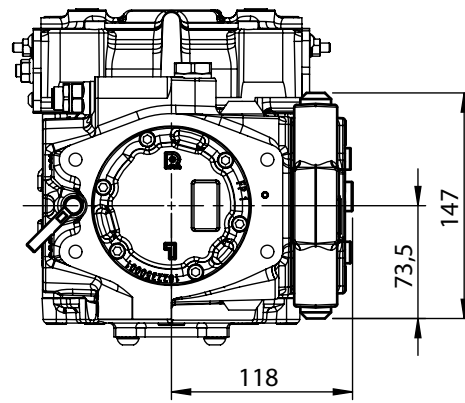
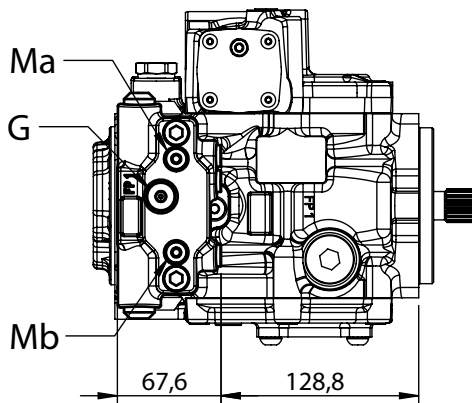
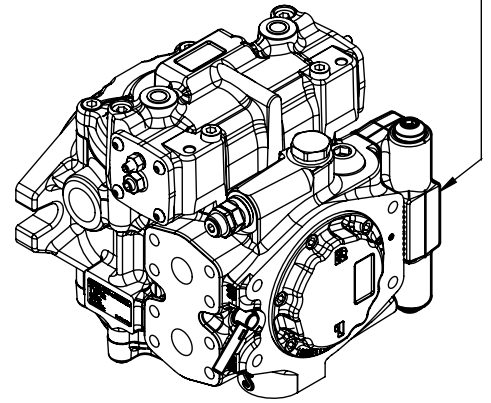

HYDRAULIC DIAGRAM

PURGE VALVE
purge flow -3.5 l/min

OPTIONAL CO (--)

PRESSURE CUT-OFF VALVE (PRESSURE SETTING)

The CO pressure cut-off valve, when the set pressure is reached, reduces the displacement of the pump in order to maintain a constant working pressure.

The valve operates in place of the pressure relief valves of the pump and increases the energy efficiency of the machine.

The cut-off valve set pressure must be 3 MPa bar lower than the setting of the relief valves.

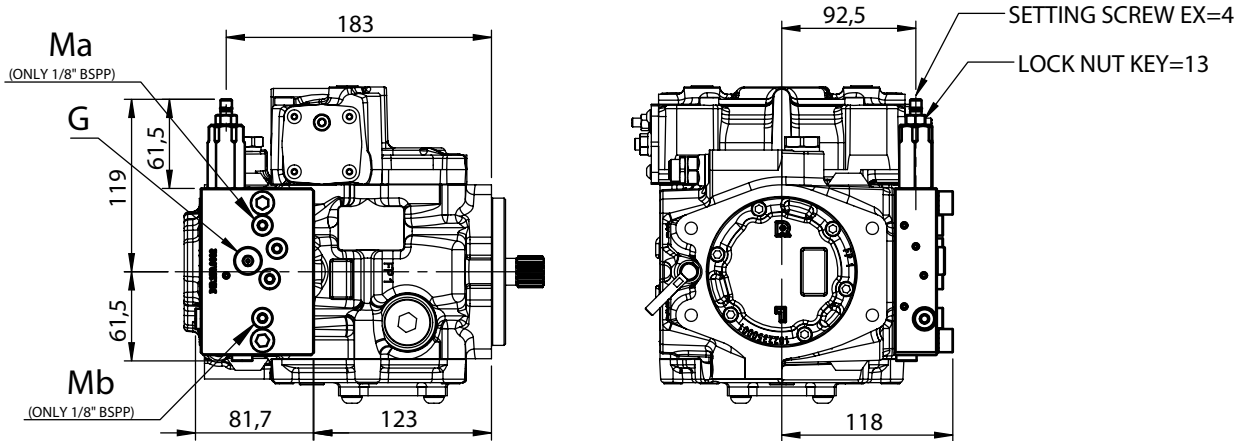
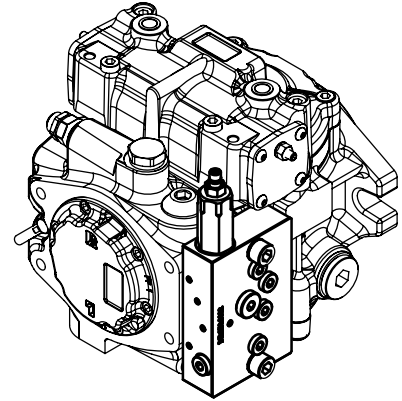

HYDRAULIC DIAGRAM

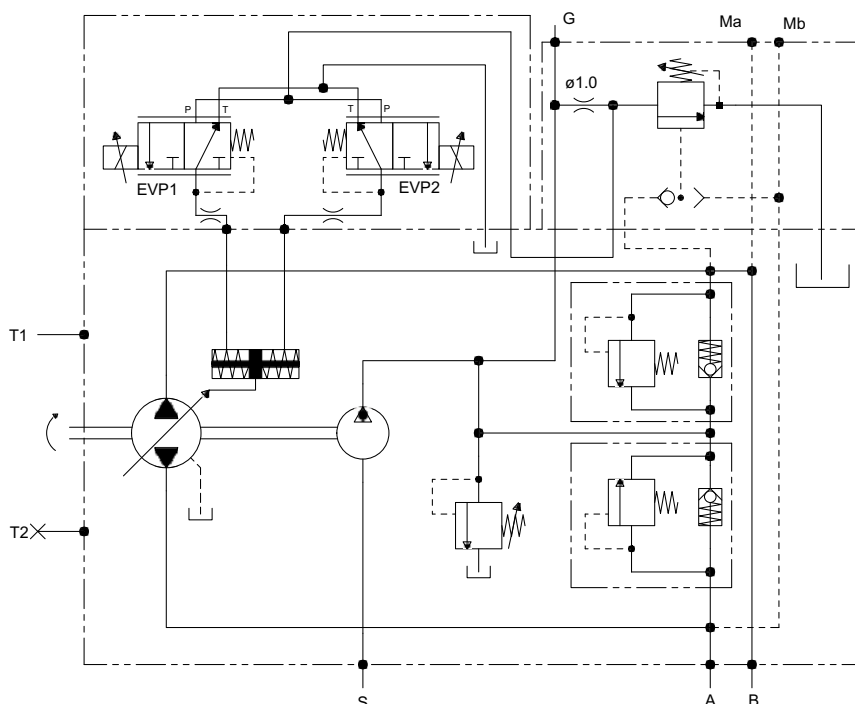

OPTIONAL FR

PRE-ARRANGED FOR CONNECTION WITH EXTERNAL FILTER

The pre-arrangement for the connection with an external filter allows the filtration of the oil of the boost pump under pressure.

The filter is not included and must be with a by-pass, filtration level 10 µm and must be of suitable size for the flow-rate of the boost pump.

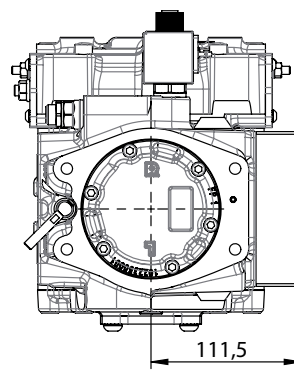
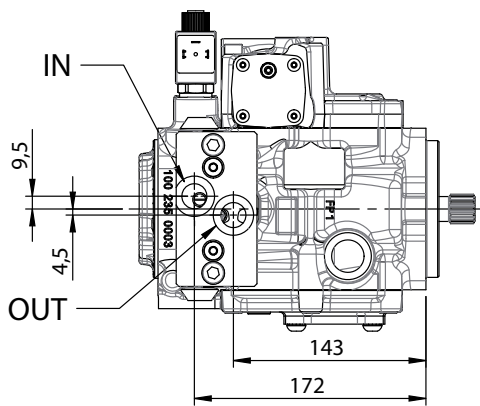
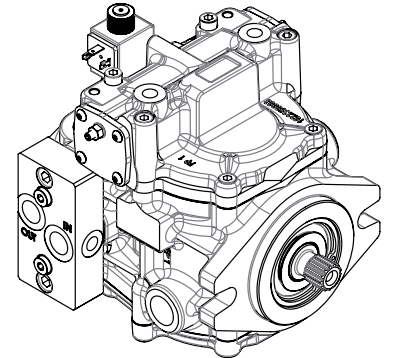

HYDRAULIC DIAGRAM

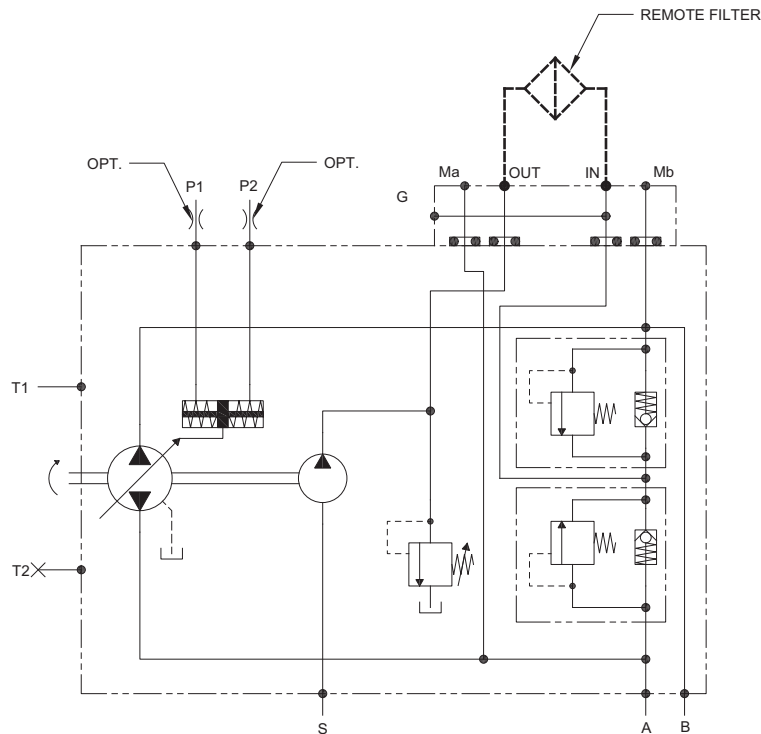

Type combinations	S	A-B	T-T1	P1-P2	Ma-Mb	IN-OUT	G
	Suction port	Main ports	Drain ports	Pilot ports	Pressure gauge ports	External filter ports	Boost gauge port
N (Standard ports)	G6	N6	G5	G2	G2 ²	G4	G2
G¹ (BSPP-Gas ports)	G6	G5	G5	G2	G2 ²	G4	G2
U¹ (UNF-UN ports)	U6	U5	U5	U2	U2 ²	U4	U2
M¹ (UNF+Flanges ports)	U6	N7	U5	U2	U2 ²	U4	U2

Nota¹: on request only, minimum 50 pcs per order
 Nota²: for optional VS, FLT, FLT1 and CO are only available G2 ports

OPTIONAL FLT

FILTER WITHOUT CLOGGING INDICATOR

To assure the oil filtration of the boost circuit, an optional filter is available, directly flanged to the pump.

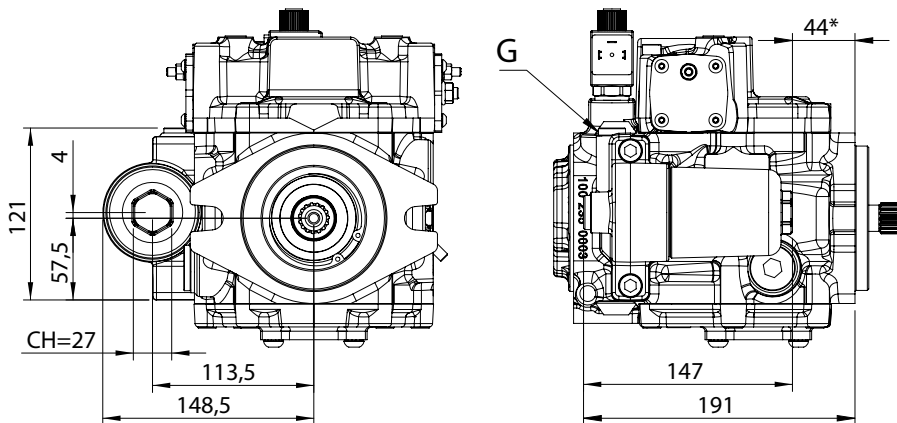
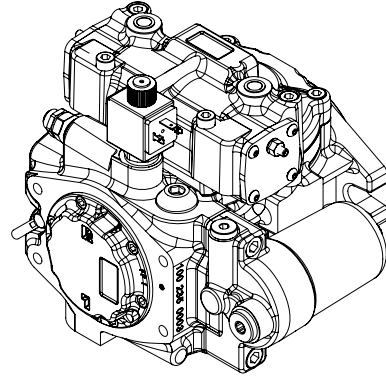

(*) min. space to allow filter replacement

HYDRAULIC DIAGRAM

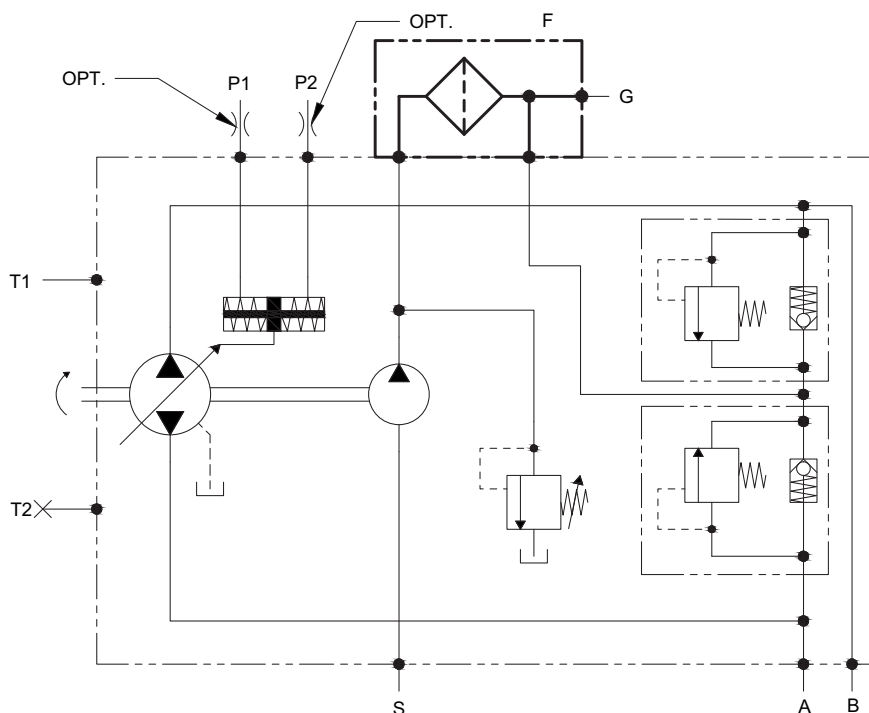

OPTIONAL FLTI

FILTER WITH CLOGGING INDICATOR

To assure the oil filtration of the boost circuit, an optional filter, with clogging indicator, is available directly flanged to the pump. The clogging indicator is set at 0,13 MPa.

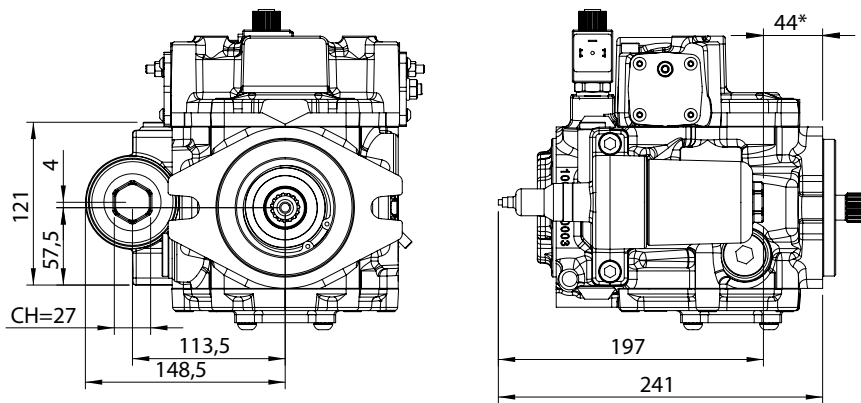
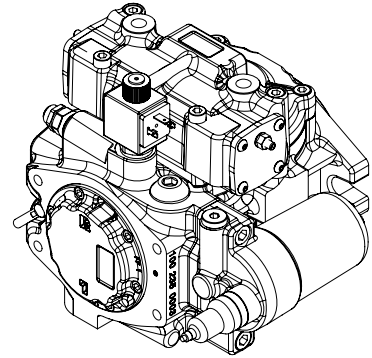

(*) min. space to allow filter replacement

HYDRAULIC DIAGRAM

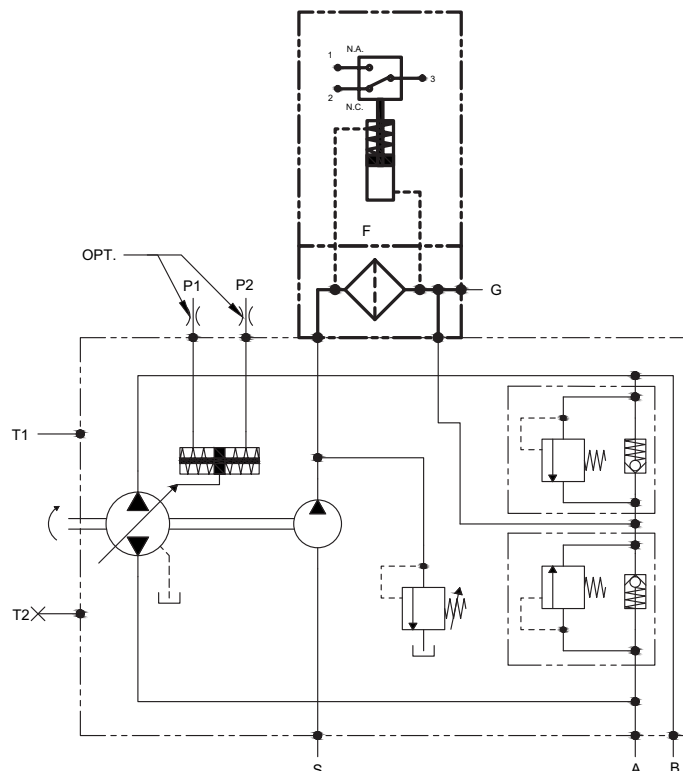

OPTIONAL MOB

MAN ON BOARD

On the pump a normally open electrical operated valve can be fitted. The valve allows the flow delivery only when energized. This function is used to increase the safety of the machine. The solenoid valve is available for 12V or 24V DC voltage.

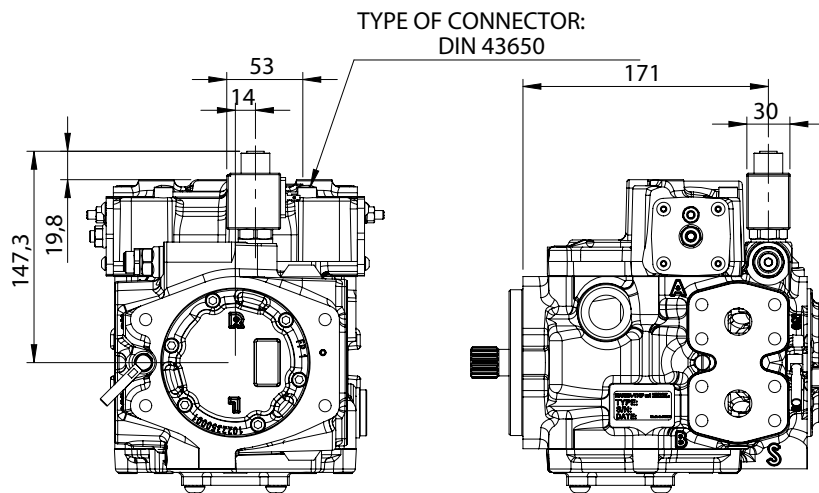
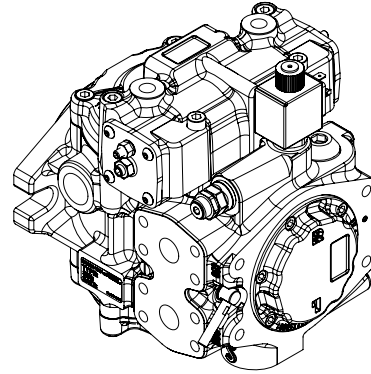

HYDRAULIC DIAGRAM

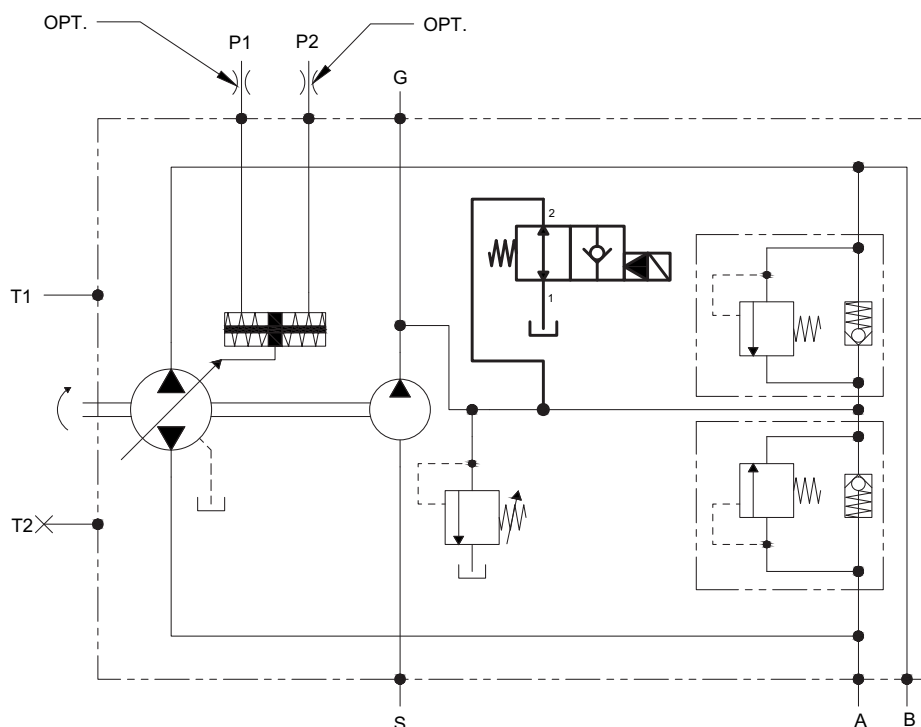

(continued)

OPTIONAL MOB

MAN ON BOARD

TECHNICAL FEATURES

VALVE MOB - Hydraulic characteristics	
Max. operating pressure	30 MPa
Max. flow	40 lt/min.
Internal leakage	max. 5 drops/min. at 30 MPa
Response time	energized 20 ms
De-energized	30 ms
Temperature range	from -20°C to 90°C



VALVE MOB - Electrical characteristics	
Power	18 W
Various voltage options available	(AC/DC)
Wire insulation	Class H
Duty factor	ED 100%
Supply power tolerance	+ 10%, - 15% (DC)
Ambient temperature	from -30°C to 60°C
Several connection options available	

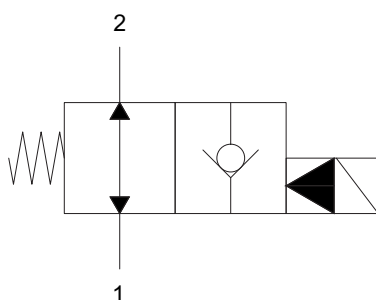

OPTIONAL RS

ANGLE SENSOR

An electronic angle sensor, to measure the swash plate position, is available for the TPV-TPVT 3600 pumps.

The signal can be used for a remote control of the pump performance. The technical features of the sensor are shown on page 51.

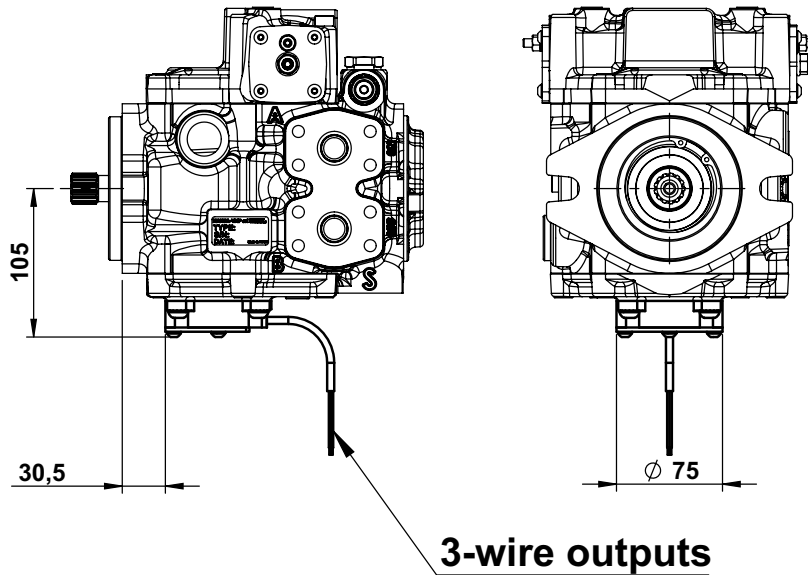
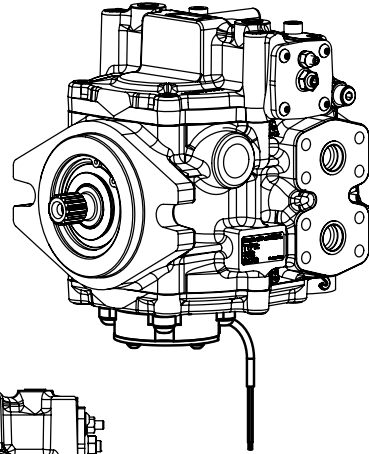

3-wire outputs

HYDRAULIC DIAGRAM

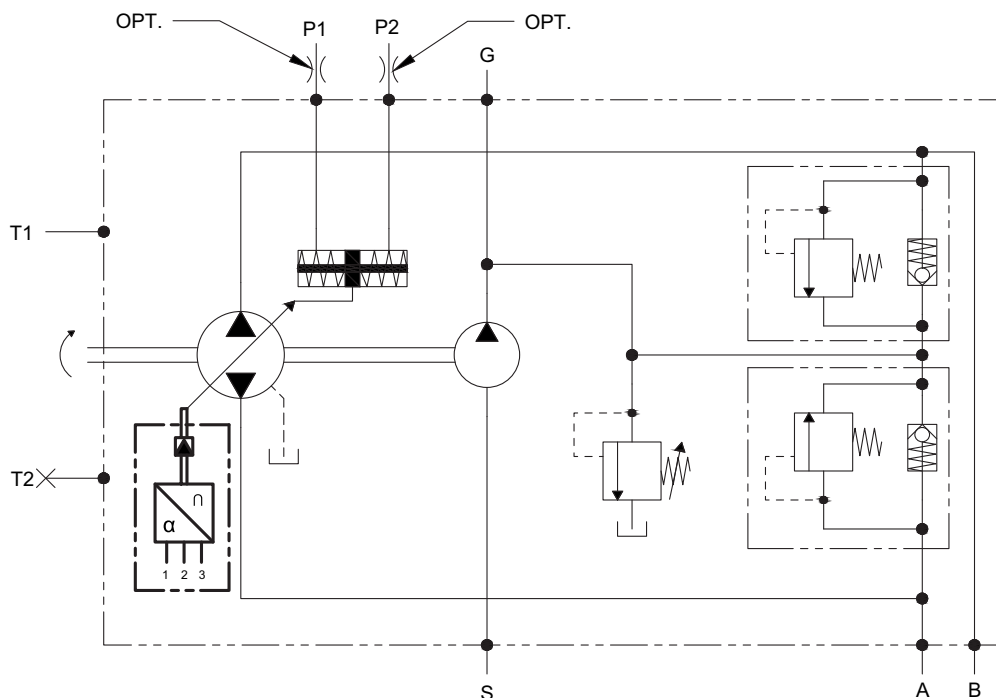

(continued)

OPTIONAL RS

ANGLE SENSOR

TECHNICAL FEATURES

- Operating voltage:** +5 Vdc
- Output signal:** +0.5 Vdc...+4.5 Vdc output with power +5 Vdc: it is recommended a load resistance > 10 KΩ
- Current consumption:** 4.5 V -> 20mA
- Angular range:** ± 20°
- Resolution (20°C):** 12 bit (analog output)
- Linearity error (20°C):** ± 0.5° FS
- Load resistance:** > 10 kohm
- Centre position:** 2.5 V
- Reverse connection protected:** yes
- Delay time of output signal:** 4 ms
- Temperature range:** -40°C...+85°C (higher

- values on request); thermal drift < 50 ppm/°C
- IP protection class:** AMP IP67
- Rotation:** clockwise CW single
- Cable length:** 1 meter



CABLE VERSION

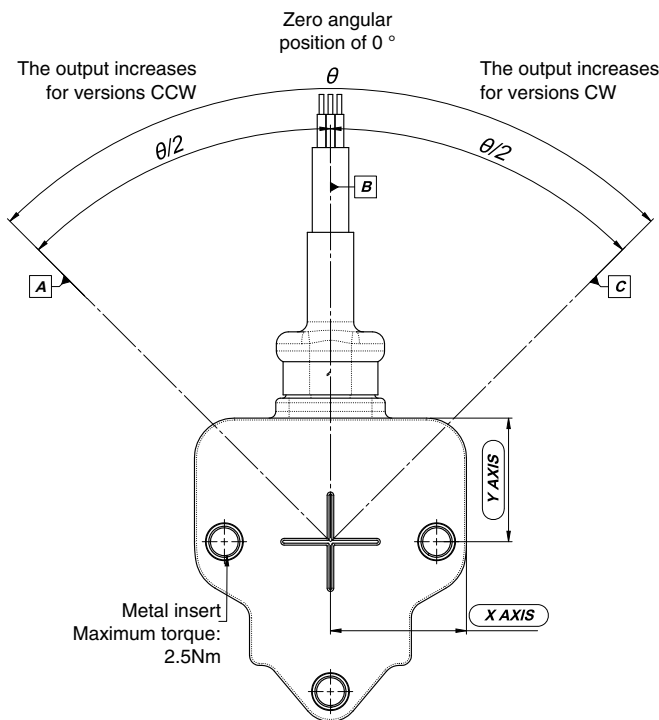

CLOCKWISE CW SINGLE DIRECTION OF ROTATION 1

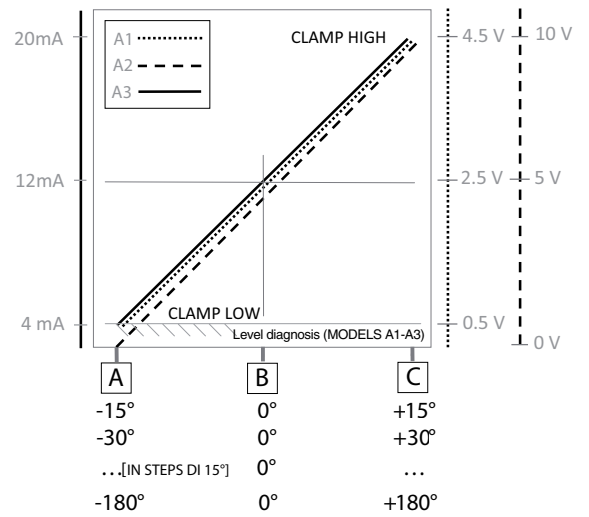

Ref.	CW Output
A	Output: 0.5Vdc
B	Zero angular position of 0°
C	Output: 4.5Vdc

cable output - PUR sheath
conductors 22 AWG

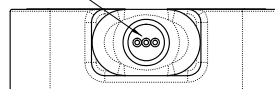

CONNECTIONS

- BLACK GROUND 1
- RED + SUPPLY 1
- YELLOW OUTPUT 1

OPTIONAL REV.S

SPEED SENSOR

A speed sensor is available to monitor the pump shaft revolution speed. The technical features are shown on page 53.

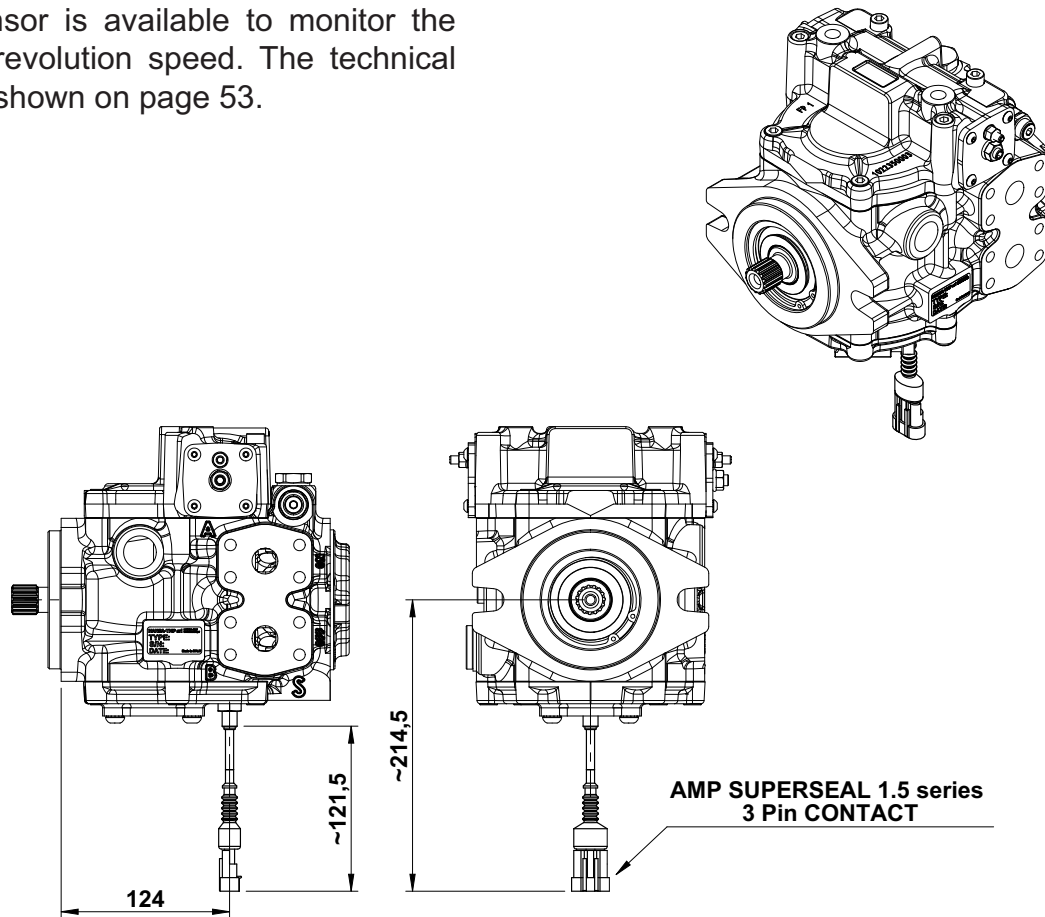

HYDRAULIC DIAGRAM

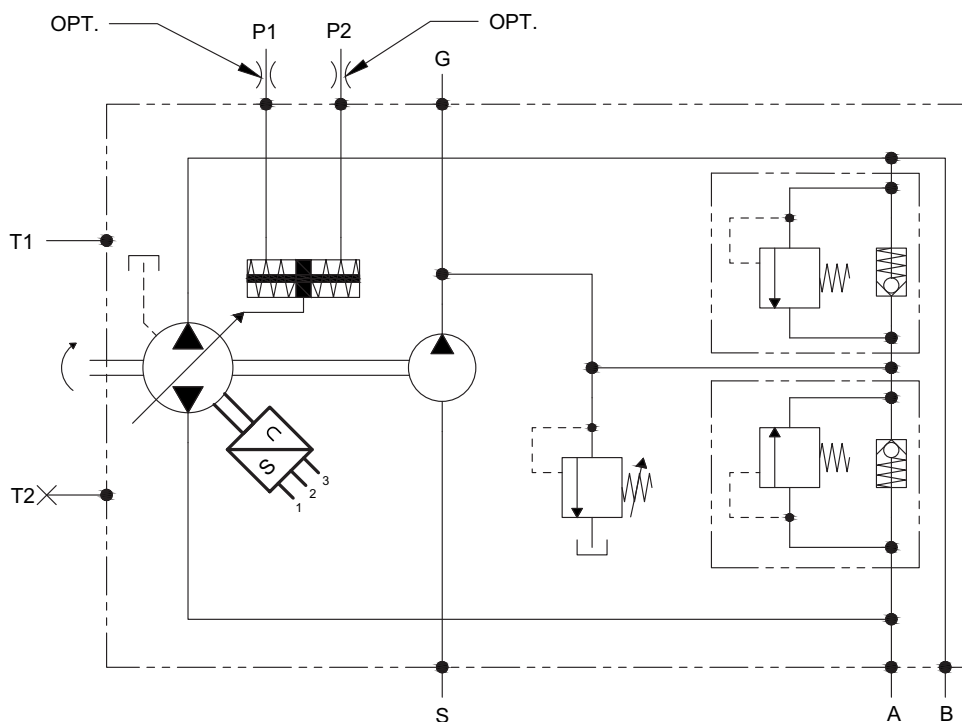

(continued)

OPTIONAL REV.S

SPEED SENSOR

TECHNICAL FEATURES

- Operating voltage:** 4.5-30 V DC
- Output current:** max 25 mA
- Maximum target:** 15 kHz
- Internal resistance:** 140 ±30 Ω
- Insulation resistance:** 145 MΩ (500 V)
- Protected by polarity inversion:** yes
- Output signal (freq):** open collector (NPN)
- Mechanical shock:** 4 g (1mm/80Hz)
- Electro magnetic compatibility:** B.C.I.
- Class "C" 100 mA, 1÷400 MHz
- Reverse polarity protection:** -30 Vdc for 1h
- Overload protection:** 30 mA for 5'
- Overvoltage protection:** 35 V for 5'
- Short circuit protection:** to ground for 5' to Vcc for 5'
- Output transite voltage protection:** V_{BR} min 31,35 max 34,65

Temperature range: -20 / +90°C

Protection class: IP 67

Tightening torque: 25 Nm

Output pins are protected against 2000 V electrostatic discharge according to HMB

Output signal/revolution = 9

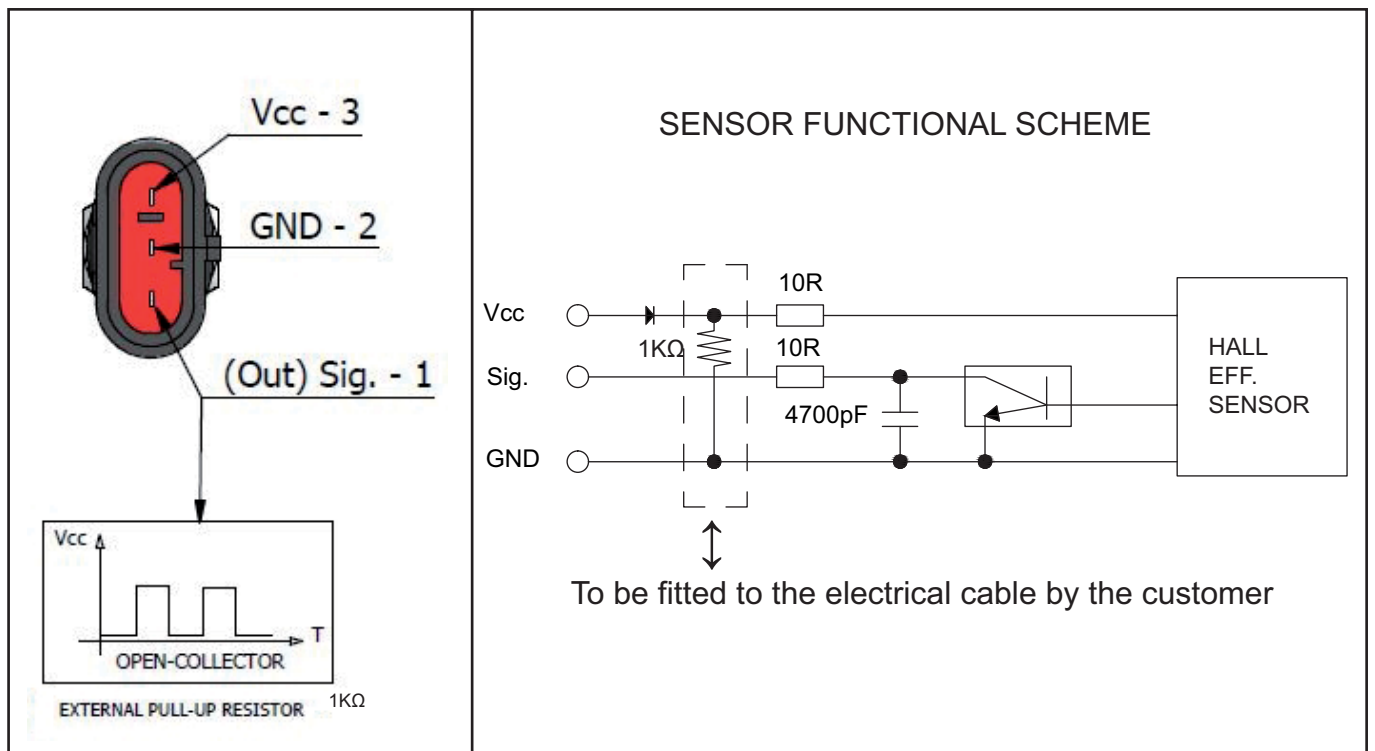

OPTIONAL PRS

PRESSURE SENSOR

The TPV-TPVT 3600 pumps can fit a pressure sensor to monitor the working pressure. These information sent and processed by an electronic remote system allow a continuous remote control of the pump performance. The technical features are shown on page 55.

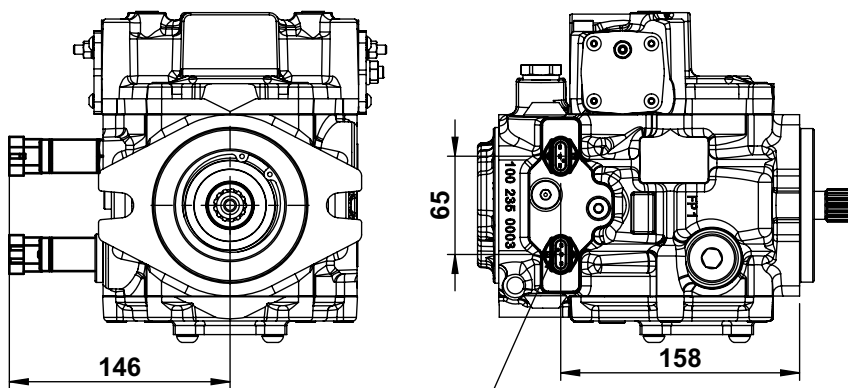
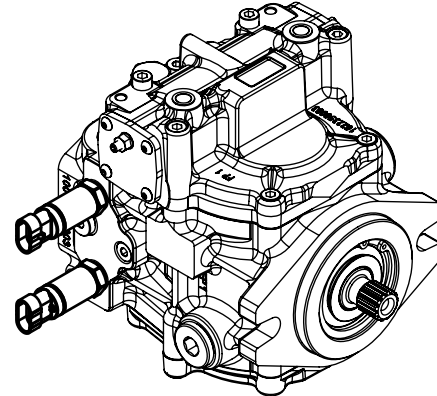

AMP Superseal 1.5 (3-pin)

HYDRAULIC DIAGRAM

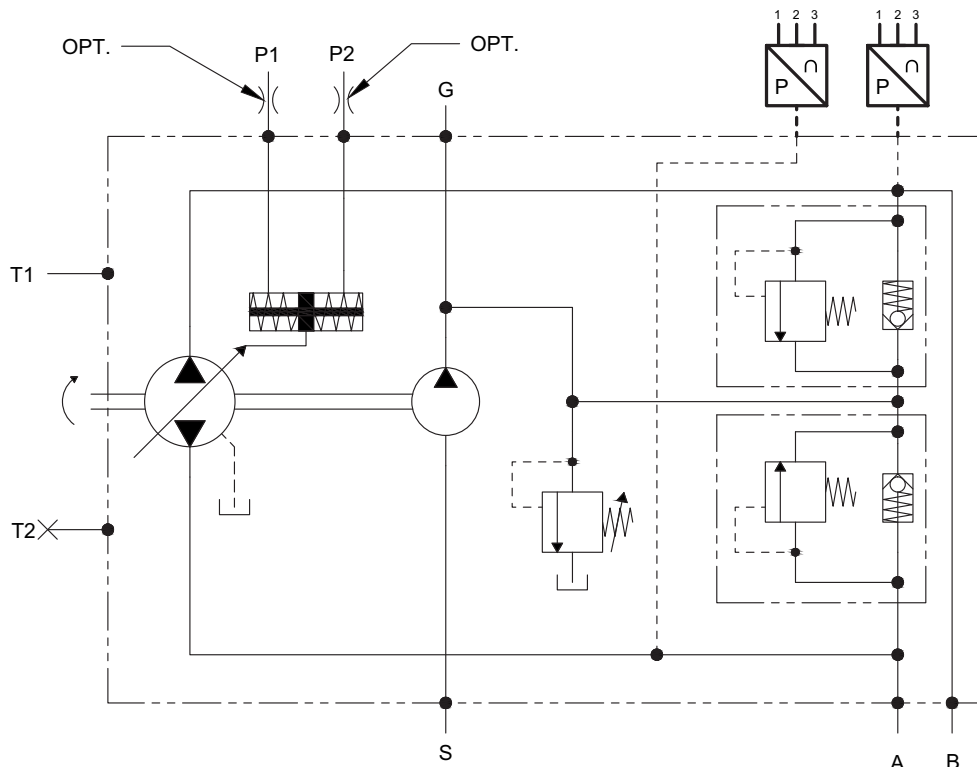

(continued)

OPTIONAL PRS

PRESSURE SENSOR

TECHNICAL FEATURES

- Pressure range:** 0-40 MPa
- Over pressure, max permitted:** 80 MPa
- Burst pressure:** 150 MPa
- Power supply U_B :** 5 ± 0.25 Volt DC
- Signal output, ratiometric @5V:** 4.5 V (X)
- Error levels, signal output:** < 0.5 V and > 4.5 Volt
- Response time:** fast (< 1 msec)
- Accuracy (IEC 61298-2):** $\pm 0.25\%$ FS BFSL
- Max load, R_A :** $\geq 5K\Omega$
- Temperature range:**
 - Operating temperature range (process): from -40°C to $+125^\circ\text{C}$
 - Operating temperature range (environment): from -40°C to $+105^\circ\text{C}$
 - Compensated temperature range: from -20°C to $+85^\circ\text{C}$

- Storage temperature range: from -40°C to $+125^\circ\text{C}$
- CE conformity acc. to:** according to EU 2014/30
- Mechanical shock:** 100g / 11 msec according to IEC 60068-2-27
- Vibration resonance:** 20g max at 10...2000 Hz according to IEC 60068-2-6
- IP protection class:** IP65 / IP67
- Weight:** 80-120 gr. Nominal
- Electric connector:** AMP Superseal 1.5 (3-pin)
- Hydraulic connection:** G 1/4 gas male (DIN 3852-E)



S - Connector AMP Superseal 1.5 (3-pin)

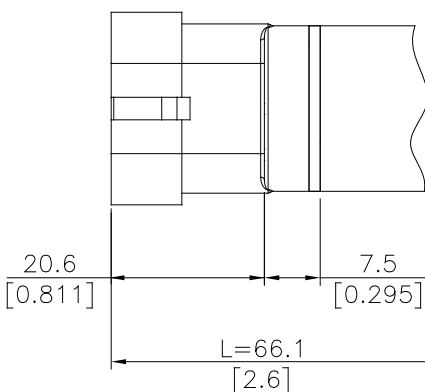

S – AMP Superseal 1.5

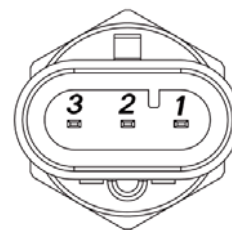

Protection rating IP67

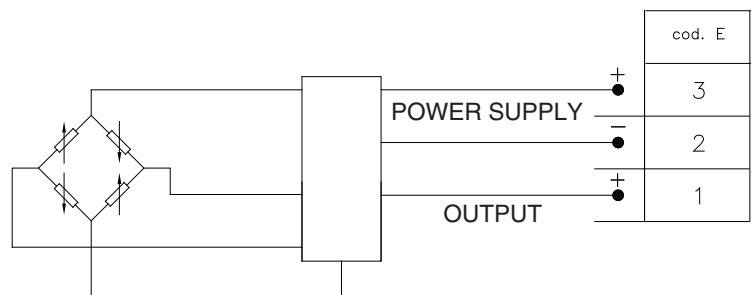

TPVT 3600

VARIABLE DISPLACEMENT AXIAL PISTON TANDEM PUMP

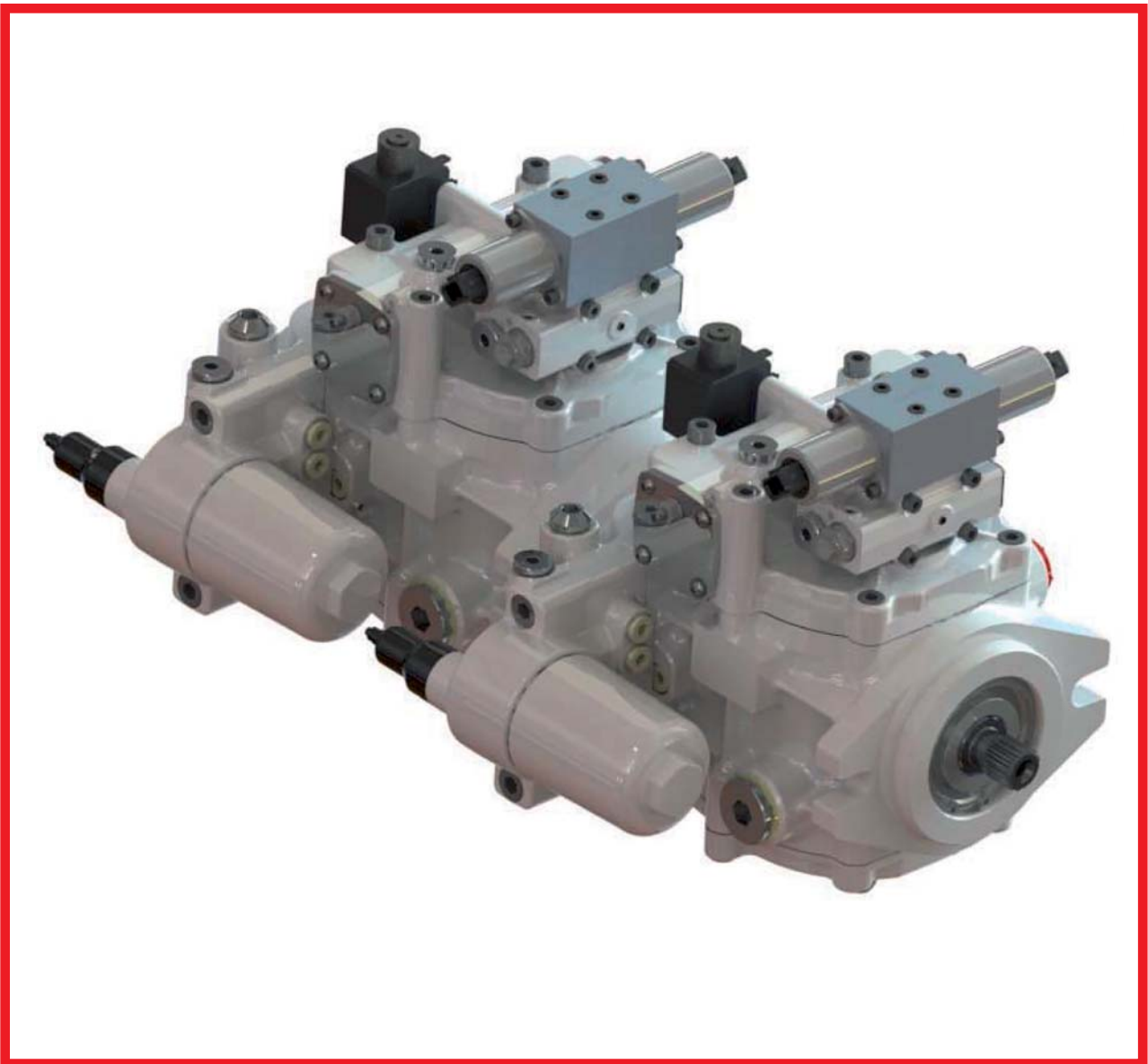

ORDER CODE (TANDEM PUMP) _____

3600	TPVT1	38	38	CR	SS3	F2	SHI	SHI	OA	OA	35	35	10	0	C	000	0	VS	FLTI	N
0	1	2	3	4	5	6	7	8	9	10	11	12	13	14	15	16	17	18	19	20

Page

3600	0 - Pump series = Series 3600									
TPVT1 TPVT2	1 - Pump model = Tandem closed loop circuit pump with single boost pump = Tandem closed loop circuit pump with double boost pump									
	2 - Pump displacement (primary pump) <table> <tr> <td>26 = 26 cm³/n</td> <td>28 = 28 cm³/n</td> <td>30 = 30 cm³/n</td> <td>32 = 32 cm³/n</td> </tr> <tr> <td>34 = 34 cm³/n</td> <td>36 = 36 cm³/n</td> <td>38 = 38 cm³/n</td> <td></td> </tr> </table>	26 = 26 cm ³ /n	28 = 28 cm ³ /n	30 = 30 cm ³ /n	32 = 32 cm ³ /n	34 = 34 cm ³ /n	36 = 36 cm ³ /n	38 = 38 cm ³ /n		
26 = 26 cm ³ /n	28 = 28 cm ³ /n	30 = 30 cm ³ /n	32 = 32 cm ³ /n							
34 = 34 cm ³ /n	36 = 36 cm ³ /n	38 = 38 cm ³ /n								
	3 - Pump displacement (secondary pump) <table> <tr> <td>26 = 26 cm³/n</td> <td>28 = 28 cm³/n</td> <td>30 = 30 cm³/n</td> <td>32 = 32 cm³/n</td> </tr> <tr> <td>34 = 34 cm³/n</td> <td>36 = 36 cm³/n</td> <td>38 = 38 cm³/n</td> <td></td> </tr> </table>	26 = 26 cm ³ /n	28 = 28 cm ³ /n	30 = 30 cm ³ /n	32 = 32 cm ³ /n	34 = 34 cm ³ /n	36 = 36 cm ³ /n	38 = 38 cm ³ /n		
26 = 26 cm ³ /n	28 = 28 cm ³ /n	30 = 30 cm ³ /n	32 = 32 cm ³ /n							
34 = 34 cm ³ /n	36 = 36 cm ³ /n	38 = 38 cm ³ /n								
CR CC	4 - Pump rotation = Clockwise Rotation (right) = Counter-clockwise rotation (left)									
SS3 SS5	5 - Shaft (mounting side) = Splined shaft SAE-B (ANSI B92.1A - 13T - 16/32 D.P.) = Splined shaft SAE-BB (ANSI B92.1A - 15T - 16/32 D.P.)	20 20								
F2	6 - Mounting flange = SAE-B 2 holes - pilot diam. 101,6 mm.	20								
SHI SEI1.3 SEI2.3 SEI1.3D SEI2.3D SHIX SMIX SEIX1.3 SEIX2.3 SEIX1.3D SEIX2.3D	7 - Control devices (primary pump) = Hydraulic servo control = Electro-proportional servo control 12V DC (AMP junior timer connector) = Electro-proportional servo control 24V DC (AMP junior timer connector) = Electro-proportional servo control 12V DC (Deutsch connector) = Electro-proportional servo control 24V DC (Deutsch connector) = Hydraulic servo control with feed back = Mechanical lever servo control with feed back = Electro-proportional servo control with feed back 12V DC (AMP junior timer connector) = Electro-proportional servo control with feed back 24V DC (AMP junior timer connector) = Electro-proportional servo control with feed back 12V DC (Deutsch connector) = Electro-proportional servo control with feed back 24V DC (Deutsch connector)	21 23 23 26 26 27 29 31 31 34 34								

(continued)

ORDER CODE (TANDEM PUMP) _____

3600	TPVT1	38	38	CR	SS3	F2	SHI	SHI	OA	OA	35	35	10	0	C	000	0	VS	FLTI	N
0	1	2	3	4	5	6	7	8	9	10	11	12	13	14	15	16	17	18	19	20

Page

8 - Control devices (secondary pump)		
SHI	= Hydraulic servo control	21
SEI1.3	= Electro-proportional servo control 12V DC (AMP junior timer connector)	23
SEI2.3	= Electro-proportional servo control 24V DC (AMP junior timer connector)	23
SEI1.3D	= Electro-proportional servo control 12V DC (Deutsch connector)	26
SEI2.3D	= Electro-proportional servo control 24V DC (Deutsch connector)	26
SHIX	= Hydraulic servo control with feed back	27
SMIX	= Mechanical lever servo contro with feed back	29
SEIX1.3	= Electro-proportional servo control with feed back 12V DC (AMP junior timer connector)	31
SEIX2.3	= Electro-proportional servo control with feed back 24V DC (AMP junior timer connector)	31
SEIX1.3D	= Electro-proportional servo control with feed back 12V DC (Deutsch connector)	34
SEIX2.3D	= Electro-proportional servo control with feed back 24V DC (Deutsch connector)	34

9 - Control devices position (primary pump)

OA	= Position A	37
OB	= Position B (On request only, minimum 50 pcs per order)	37

10 - Control devices position (secondary pump)

OA	= Position A	37
OB	= Position B (On request only, minimum 50 pcs per order)	37

11 - Relief valve settings (primary pump)

10 = 10 MPa	15 = 15 MPa	18 = 18 MPa	20 = 20 MPa
25 = 25 MPa	30 = 30 MPa	35 = 35 MPa	40 = 40 MPa
45 = 45 MPa			

12 - Relief valve settings (secondary pump)

10 = 10 MPa	15 = 15 MPa	18 = 18 MPa	20 = 20 MPa
25 = 25 MPa	30 = 30 MPa	35 = 35 MPa	40 = 40 MPa
45 = 45 MPa			

13 - Boost pump (primary pump)

00	= Without boost pump *
10	= Standard boost pump 10,3 cm ³ /n - pressure 2 MPa at 1.000 n/min.
10 (XX)	= Standard boost pump 10,3 cm ³ /n - other pressure setting 2÷3 MPa at 1000 n/min., please contact our technical departement for details

14 - Boost pump (secondary pump)

00	= Without boost pump *
10	= Standard boost pump 10,3 cm ³ /n - pressure 2 MPa at 1.000 n/min.
10 (XX)	= Standard boost pump 10,3 cm ³ /n - other pressure setting 2÷3 MPa at 1000 n/min., please contact our technical departement for details

* Upon order, please provide information on maximum external charge flow.

(continued)

ORDER CODE (TANDEM PUMP) _____

3600	TPVT1	38	38	CR	SS3	F2	SHI	SHI	OA	OA	35	35	10	0	C	000	0	VS	FLTI	N
0	1	2	3	4	5	6	7	8	9	10	11	12	13	14	15	16	17	18	19	20

Page

15 - Rear pump connection options	
C	= Closed cover 38
B1	= German standard pump group 1 mounting 38
SA	= SAE-A 2 holes mounting flange (9T 16/32 D.P. female shaft) 39
SB	= SAE-B 2 holes mounting flange (13T 16/32 D.P. female shaft) 39

16 - Auxiliary gear pump displacements	
000	= Without gear pump

Group 1

112 = 1,2 cm ³ /n	117 = 1,7 cm ³ /n	122 = 2,2 cm ³ /n	126 = 2,6 cm ³ /n
132 = 3,1 cm ³ /n	138 = 3,6 cm ³ /n	143 = 4,2 cm ³ /n	149 = 4,9 cm ³ /n
159 = 5,9 cm ³ /n	165 = 6,5 cm ³ /n	178 = 7,5 cm ³ /n	

Group 2 (only SAE-A)

204 = 4,2 cm ³ /n	206 = 6,0 cm ³ /n	209 = 8,4 cm ³ /n	211 = 10,8 cm ³ /n
214 = 14,4 cm ³ /n	217 = 16,8 cm ³ /n	219 = 19,2 cm ³ /n	222 = 22,8 cm ³ /n
226 = 26,2 cm ³ /n	230 = 30,0 cm ³ /n	240 = 40,0 cm ³ /n	

Group 3 (only SAE-B)

315 = 15,0 cm ³ /n	318 = 18,0 cm ³ /n	321 = 21,0 cm ³ /n	327 = 27,0 cm ³ /n
332 = 32,0 cm ³ /n	338 = 38,0 cm ³ /n	343 = 43,0 cm ³ /n	347 = 47,0 cm ³ /n
351 = 51,0 cm ³ /n	354 = 54,0 cm ³ /n	361 = 61,0 cm ³ /n	364 = 64,0 cm ³ /n
370 = 70,0 cm ³ /n	374 = 74,0 cm ³ /n	390 = 90,0 cm ³ /n	

17 - Optional Voltage

0	= Without
1	= 12V DC
2	= 24V DC

18 - Optional

0	= Without optional	
LB	= By-pass a leva	40
VS	= Purge valve	41
CO (--)	= Pressure sensor	42
FR	= Pre-arranged for connection with external filter	43
FLT	= Filter without clogging indicator	44
FLTI	= Filter with clogging indicator	45
MOB	= Man on board	46
RS	= Angle sensor	48
REV.S	= RPM Sensor	50
PRS	= Pressure sensor	52
XX	= Restrictor diameter: 05=0,5 - 06=0,6 - 07=0,7 - 08=0,8 - 10=1,0 - 12=1,2	

(continued)

ORDER CODE (TANDEM PUMP) _____

3600	TPVT1	38	38	CR	SS3	F2	SHI	SHI	OA	OA	35	35	10	0	C	000	0	VS	FLTI	N
0	1	2	3	4	5	6	7	8	9	10	11	12	13	14	15	16	17	18	19	20

Page

0	= Without optional	40
LB	= Lever by-pass	41
VS	= Purge valve	42
CO (--)	= Pressure cut-off valve (pressure setting)	43
FR	= Pre-arranged for connection with external filter	44
FLT	= Filter without clogging indicator	45
FLTI	= Filter with clogging indicator	46
MOB	= Man on board	48
RS	= Angle sensor	50
REV.S	= RPM Sensor	52
PRS	= Pressure sensor	
XX	= Restrictor diameter: 05=0,5 - 06=0,6 - 07=0,7 - 08=0,8 - 10=1,0 - 12=1,2	

20 - Port combinations (please contact out technical department)

N/G/U/M = Port threads (N for standard version)

Type combinations	S	A-B	T-T1	P1-P2	Ma-Mb	IN-OUT	G
	Suction port	Main ports	Drain ports	Pilot ports	Pressure gauge ports	External filter ports	Boost gauge port
N (Standard ports)	G6	N6	G5	G2	G2 ²	G4	G2
G¹ (BSPP-Gas ports)	G6	G5	G5	G2	G2 ²	G4	G2
U¹ (UNF-UN ports)	U6	U5	U5	U2	U2 ²	U4	U2
M¹ (UNF+Flanges ports)	U6	N7	U5	U2	U2 ²	U4	U2

Nota¹: on request only, minimum 50 pcs per order

Nota²: for optional VS, FLT, FLTI and CO are only available G2 ports

SAE flange ports 3/4" SAE 6000	Type	M		N		O		P		Q	
		mm	in	mm	in	mm	in	mm	in	mm	in
	N6	19	0,75	50,8	2,0	M10	50	20	0,79	23,8	0,94

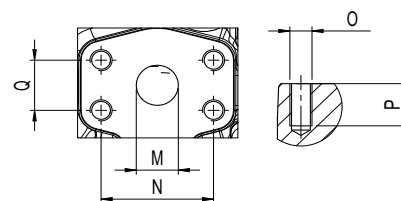

ISO 1179-1 ports for BSPP thread	Type	M	
		Dim.	Assembly torque Nm
	G1	1/8"-28	25
	G2	1/4"-19	40
	G4	1/2"-14	100
	G5	3/4"-14	190
	G6	1"-11	320

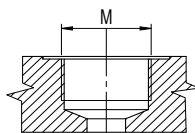

ISO 11926-1 ports for UNF-UN thread	Type	N	
		Dim.	Assembly torque Nm
	U1	7/16-20	21
	U2	9/16-18	40
	U4	7/8-14	100
	U5	1"1/16-12	180
	U6	1"5/16-12	285

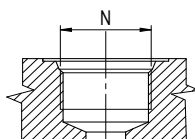

GENERAL DIMENSIONS TANDEM PUMP TPVT1 WITH SINGLE BOOST PUMP

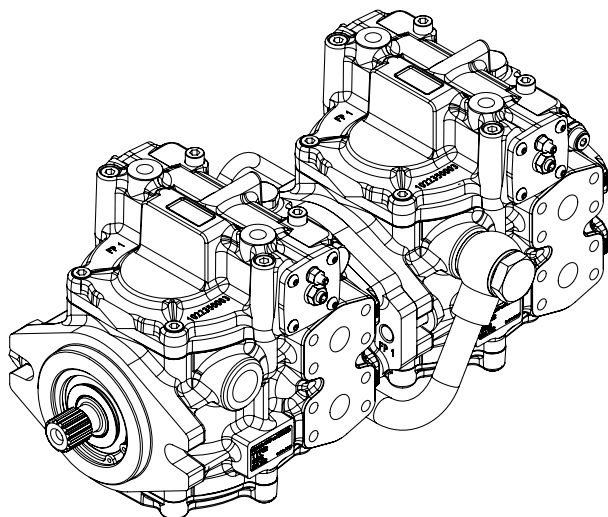
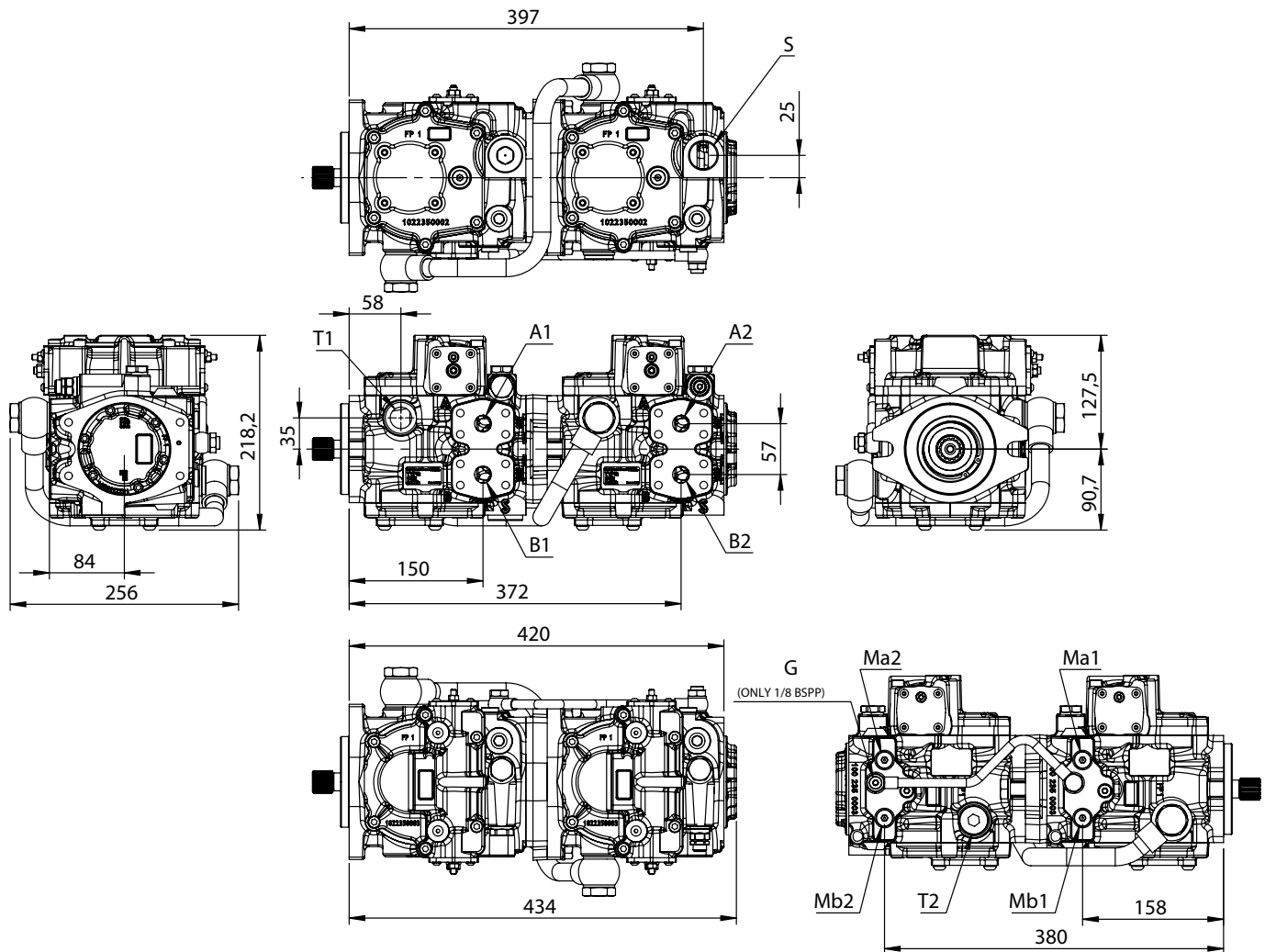

HYDRAULIC CONNECTIONS STANDARD COMBINATION "N"		
A1 - B1	Main pressure ports 1	3/4" SAE 6000
A2 - B2	Main pressure ports 2	3/4" SAE 6000
T1 - T2	Drain	3/4" BSPP
S	Suction	1" BSPP
G	Boost pump pressure gauge port	1/8" BSPP
MA1- MB1 MA2 - MB2	Pressure gauge ports	1/4" BSPP

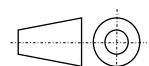

GENERAL DIMENSIONS TANDEM PUMP TPVT2 WITH DOUBLE BOOST PUMP

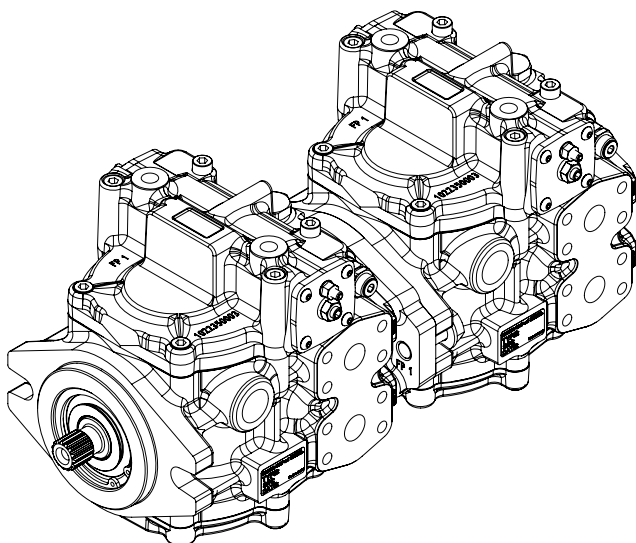
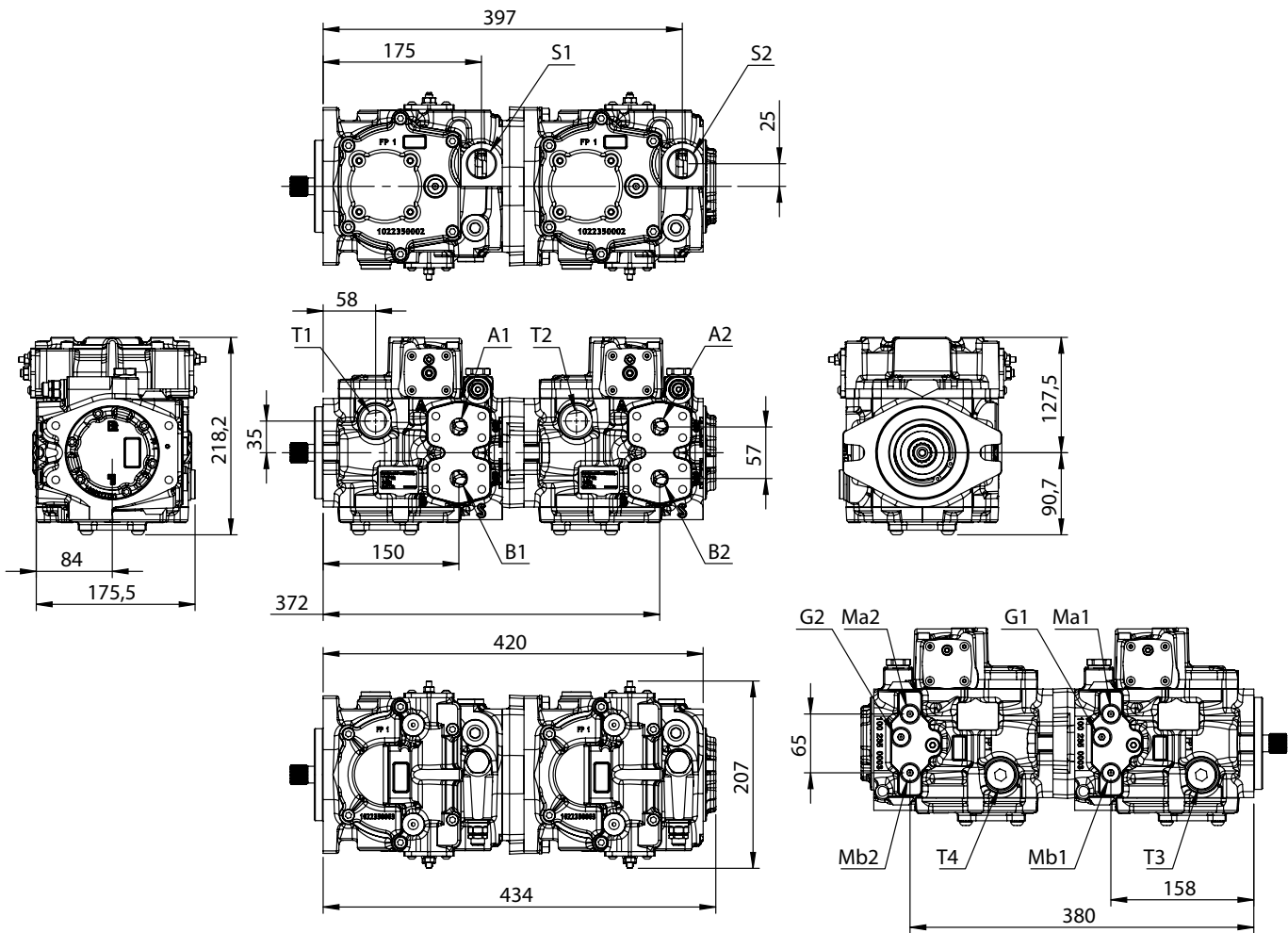

HYDRAULIC CONNECTIONS STANDARD COMBINATION "N"		
A1 - B1	Main pressure ports 1	3/4" SAE 6000
A2 - B2	Main pressure ports 2	3/4" SAE 6000
T1 - T2	Drain	3/4" BSPP
S	Suction	1" BSPP
G1 - G2	Boost pumps pressure gauge ports	1/4" BSPP
MA1- MB1 MA2 - MB2	Pressure gauge ports	1/4" BSPP

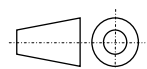

EXAMPLE TANDEM TPVT1 PUMP:

3600 TPVT1 32 32 CR SS5 F2 SHI SHI OA OA 30 30 00 10 C 000 0 0 FLTI N

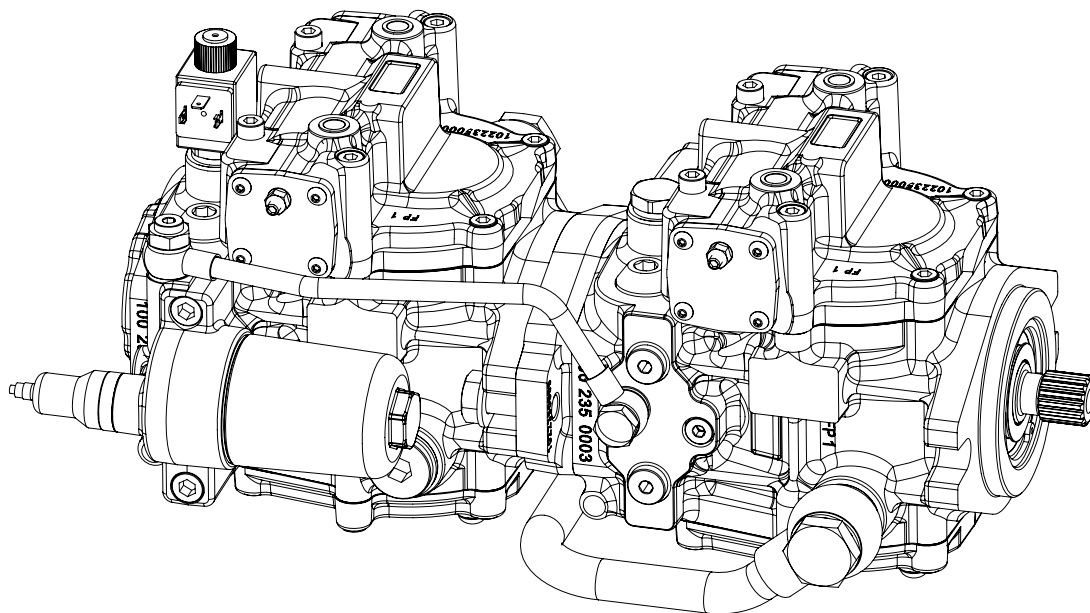

HYDRAULIC DIAGRAM

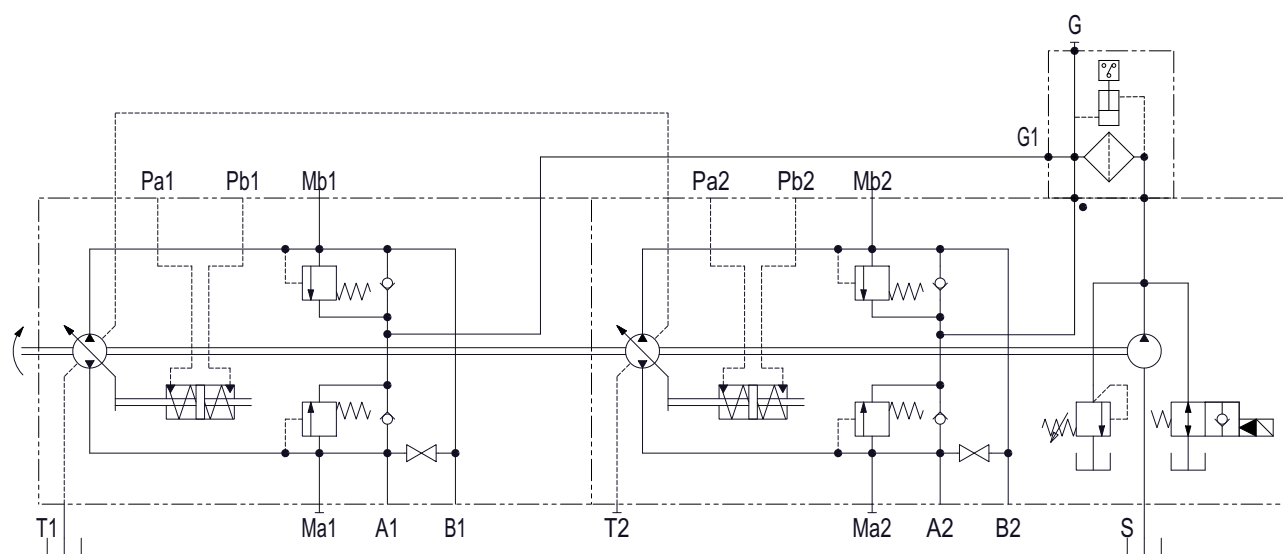

EXAMPLE TANDEM TPVT2 PUMP:

3600 TPVT2 38 38 CR SS5 F2 SHI SHI OA OB 35 35 10 10 C 000 0 0 0 N

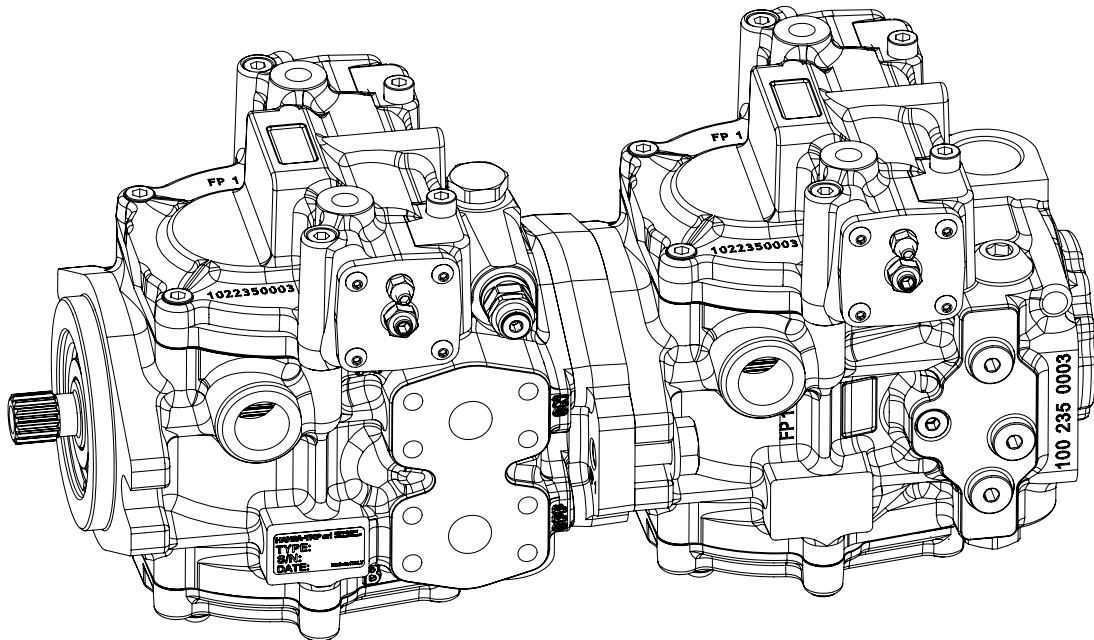

HYDRAULIC DIAGRAM

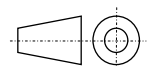
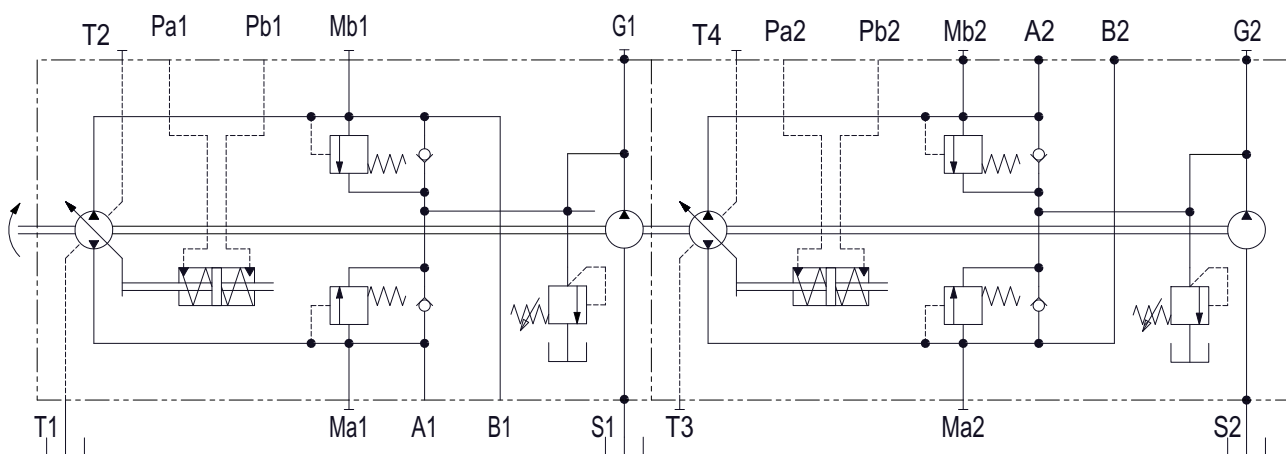

ASSEMBLY WITH VARIOUS OPTIONALS

PUMP SHOWN IS WITH OPTIONS: LB, CO, VS, FLTI, MOB

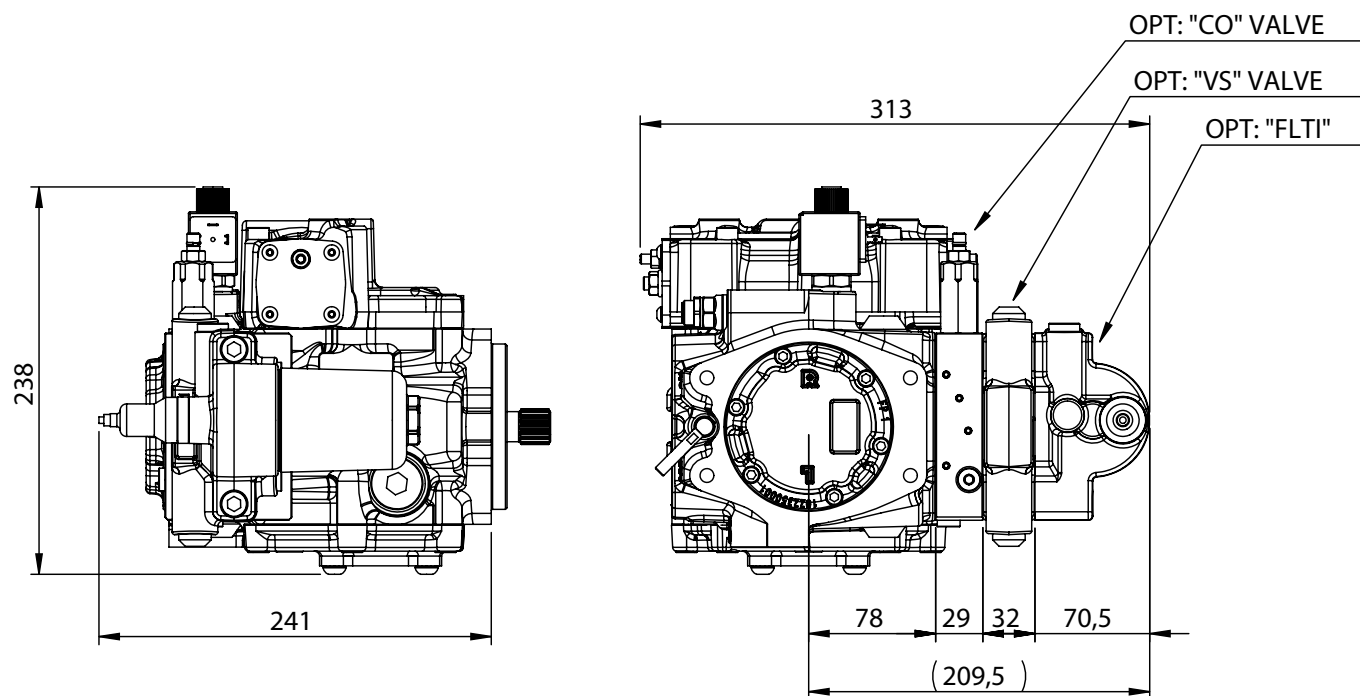

CO, VS and FLTI options can be combined in many ways to match the system requirements. The overall dimensions of the pump can be calculated adding the size of the options as shown in the picture above.

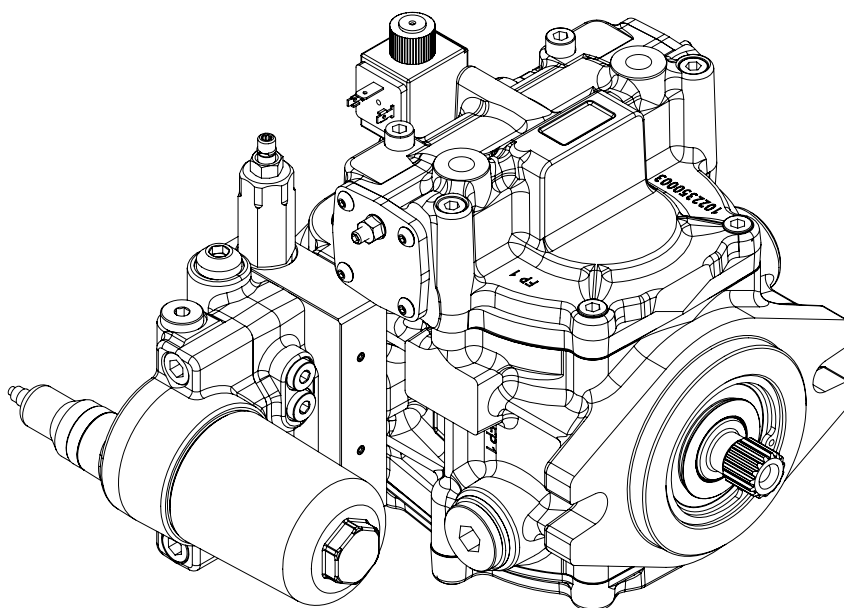

PUMPS



Closed Loop Axial Piston Pumps (Variable Displacement) - 6-110 cc

Model	Displacement cm ³ /n.	Rated Pressure MPa	Peak Pressure MPa	Maximum speed n/min.	Weight kg (single pump)
TPV 1000 TPV 1200 BTB	6, 8, 9, 11, 12, 13	21	30	3.600	8,8
	15, 17		28		
	18		27		
	19, 21	20	25	3.200	
TPV-TPVTC 1500	17, 18, 19, 21	35	40	3.600	14
TPV 3200	21, 28	25	35		22
TPV-TPVT 3600	26, 28, 30, 31, 32, 34, 36, 38	35	45		28
TPV 4300	32, 38, 45, 50	25	35		23
TPV 5000	46, 50, 64	30	40		29
TPV 9000	55	40	45	4.000	55
	72			4.100	68
	90			4.000	
	110			3.800	



Open Loop Axial Piston Pumps (Fixed Displacement) - 32-50 cc

Model	Displacement cm ³ /n.	Rated Pressure MPa	Peak Pressure MPa	Maximum speed n/min.	Weight kg (single pump)
TPF 60	35, 40, 46	35	42	2.800	20,5
	50		41	2.500	



Bent Axis Pumps - 12-130 cc

Model	Displacement cm ³ /n.	Rated Pressure MPa	Peak Pressure MPa	Maximum speed n/min.	Weight kg
TPB - TAP 70	12.6	35	40	3.300	7,5
	17.0			3.200	
	25.4			2.550	8,5
	34.2			2.250	
	41.2, 47.1			2.200	15,5
	56.0			2.100	
	63.6			2.050	
	83.6, 90.7, 108.0			1.700	27,0
	130.0			1.600	29,5

The table values can change in function of the configuration.

As HANSA-TMP has a very extensive range of products and some products have a variety of applications, the information supplied may often only apply to specific situations.

If the catalogue does not supply all the information required, please contact HANSA-TMP.

In order to provide a comprehensive reply to queries we may require specific data regarding the proposed application.

Whilst every reasonable endeavour has been made to ensure accuracy, this publication cannot be considered to represent part of any contract, whether expressed or implied.

The data in this catalogue refer to the standard product. The policy of HANSA-TMP consists of a continuous improvement of its products. It reserves the right to change the specifications of the different products whenever necessary and without giving prior information.



HYDRAULIC COMPONENTS
HYDROSTATIC TRANSMISSIONS
GEARBOXES - ACCESSORIES

Via M. L. King, 6 - **41122 MODENA (ITALY)**

Tel: +39 059 415 711

Fax: +39 059 415 730

INTERNET: <http://www.hansatmp.it>

E-MAIL: hansatmp@hansatmp.it