

CHECKBALL PISTON PUMPS

www.dynexhydraulics.com



 **DYNEX**
High Pressure Hydraulics

Pumps for Improved Performance in Demanding Applications



Operating With Water-Based Fluids in Offshore Systems

Pumps for wellhead safety control systems operate with water glycol and other water-based fluids at pressures to 15 000 psi (1040 bar). The single-fluid design eliminates the potential for fluid cross-contamination and avoids the cost of a lubrication circuit.

Tolerant of Severe Heat and Contamination in Mills

High-pressure pump/motor sets in steel mills supply the lube systems on finishing stands of the strip mill. The pumps are ideal for critical environments subject to severe heat and contamination. They provide the performance of a triplex pump at half the size, weight and cost.

High-Pressure Operation on Tunneling Equipment

Checkball pumps on tunneling equipment operate at pressures to 15 000 psi (1000 bar), providing high-force pipe jacking in difficult, dirty conditions. On boring machines, one Split-Flow® pump reduces system costs, supplying independent flows to multiple cylinders for steering functions.

Multiple-Outlet Pumps for Synchronized Lifting

Transfer tables in marine shipyards use Split-Flow® pumps to supply consistent flow for synchronized lifting. High-pressure multiple-outlet pumps used for lifting and skidding of heavy loads provide greater accuracy with lower cost than flow dividers.

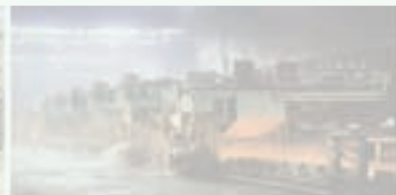

USING THIS BROCHURE

This brochure contains specifications for the most commonly used checkball pumps. Contact the sales department for availability of models with features and operating requirements not shown here.

Refer to page 42 for general fluid guidelines and information on ports. Request Bulletin PSI.CB for checkball pump installation and operating recommendations.

Brochure Notes

Specifications shown were in effect when printed. Since errors or omissions are possible, contact your sales representative or the sales department for the most current specifications before ordering.

Dynex reserves the right to discontinue products or change designs at any time without incurring any obligation.

Table of Contents

Pump Type and Series	Page
Fixed Displacement Pumps	3
PF500 Series (S.A.E. A-A 2-bolt)	4
PF1000 Series (S.A.E. A 2-bolt)	7
PF2000 Series (S.A.E. B 2-bolt)	10
PF2000 Series (Special Mounting)	12
PF3000 Series (S.A.E. C 4-bolt)	14
PF4000 Series (S.A.E. D 4-bolt)	17
PF4200 Series (S.A.E. D 4-bolt)	20
PF4300 Series (S.A.E. D 4-bolt)	23
PF6000 Series (S.A.E. E 4-bolt)	26
Mechanical Variable Delivery Pumps	29
PV4000 Series (S.A.E. D 4-bolt)	30
PV4000 Series Pressure Compensated (S.A.E. D 4-bolt)	32
PV6000 Series Pressure Compensated (S.A.E. E 4-bolt)	35
Hydraulic Variable Delivery Pumps	38
PV6000 Series (S.A.E. E 4-bolt)	39
Fluid Guidelines and Outlet Port Configurations	42

HOW THE PUMPS OPERATE

The checkball pump design uses two check valves in each piston pumping chamber to direct flow from the inlet side of the pump to the pump outlet port.

Wobble Plate Rotates with Shaft

During operation, a fixed angle wobble plate rotates with the drive shaft. The angled surface of the wobble plate imparts a reciprocating motion to the pistons which move in and out of the bores in the stationary barrel.

During its suction stroke, each piston is filled through its inlet check valve. Fluid is drawn by vacuum into the piston pumping chamber in the barrel.

Check Valves Control Fluid

During compression, the inlet check valve closes and pressure in the pumping chamber rises until it exceeds load pressure at the outlet port.

The outlet checkball then lifts off its seat and fluid is pumped

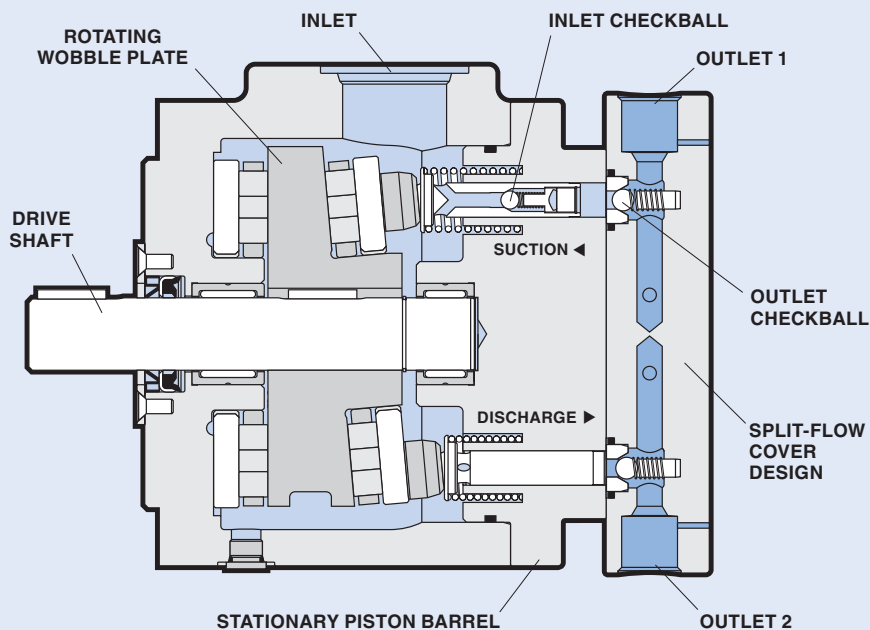

across the check valve, out of the pumping chamber. Piston outputs are combined in the pump barrel or cover, and then discharged from the pump outlet providing smooth flow to the system.

Multiple Outlet Pumps

In Split-Flow® models, the piston outputs can be isolated, or grouped together in various combinations, supplying flows to multiple function circuits without flow dividers.



PUMP DESCRIPTION

Fixed displacement checkball pumps, with bi-directional shaft rotation, provide constant direction of output flow regardless of the direction of drive shaft rotation.

Typical Applications

Reduced power requirements, as low as 1.0 HP at 10 000 psi (0.7 kW at 700 bar), make these pumps ideal for use in remote locations with limited power supply.

These compact high-pressure pumps can be used on portable power packs for high-pressure torque wrenches and other service tools. Split-Flow® models with multiple outlets are ideal for tool circuits with changing flow and pressure requirements.

Mounting

S.A.E. A-A 2-bolt pattern with 0.25 inch (6,4 mm) pilot engagement.

Shaft

Available with 0.625 inch (15,88 mm) diameter keyed shaft.

Outlet Port Options

Standard pressure models have S.A.E. ports. The high pressure "H" option requires the use of outlet port option "A" (Autoclave Medium Pressure, Butech M/P or equivalent fittings), or outlet port option "B" (British Standard Pipe fittings).

Inlet Conditions

Pumps may require pressurized inlet conditions at higher speeds. Failure to meet minimum inlet requirements will result in a slight flow reduction. Refer to the table.

Seal Options

Standard seals are Fluorocarbon (Viton® or Fluorel®). Options include EPR seals for

Specifications

Pump Models	Output Flow at 1500 rpm ^①		Output Flow at 1800 rpm ^①		Rated Pressure		Maximum Intermittent Pressure		Rated Speed rpm ^②	Maximum Speed rpm ^③
	U.S. gpm	L/min	U.S. gpm	L/min	psi	bar	psi	bar		
PF501-11	0.17	0,66	0.21	0,79	8000	560	8000	560	1800	3600
PF504-11	0.28	1,04	0.34	1,28	8000	560	8000	560	1800	3600
PF507-11	0.38	1,45	0.46	1,76	8000	560	8000	560	1800	3600
PF510-11	0.57	2,16	0.69	2,59	8000	560	8000	560	1800	3600
PF501H-11	0.17	0,64	0.20	0,75	10 000	700	15 000	1040	1800	3600
PF504H-11	0.27	1,02	0.32	1,22	10 000	700	15 000	1040	1800	3600
PF507H-11	0.37	1,40	0.45	1,70	10 000	700	15 000	1040	1800	3600
PF510H-11	0.56	2,12	0.67	2,52	10 000	700	15 000	1040	1800	3600

- ① Output flow based on typical performance at rated pressure with pressurized inlet where required, as shown in the table below.
 ② Contact the sales department for applications requiring continuous duty operation at speeds higher than 1800 rpm or lower than 900 rpm. See "Typical Performance Curves" on page 5.
 ③ Higher than rated speeds may require a pressurized inlet. Refer to "Inlet Conditions".

Minimum Inlet Pressure^①

Pump Models	Operating Speed					
	1800 rpm		2800 rpm		3600 rpm	
	psi	bar	psi	bar	psi	bar
PF501 and PF504	0	0	0	0	5	0,4
PF507	0	0	5	0,4	10 ^②	0,7 ^②
PF510	0	0	10 ^②	0,7 ^②	15 ^②	1,0 ^②

- ① Values shown are based on fluid viscosity of 100 SUS (20 cSt).
 ② Inlet pressures higher than 10 psig (0,7 bar) require a high-pressure shaft seal. Refer to "Typical Model Code" on page 6 for seal options.

use with some phosphate ester fluids, or Fluorocarbon with high pressure shaft seal.

Weight (Mass)

11.9 lb (5,4 kg)

PUMP SELECTION

The table shows specifications for standard pressure models and "H" option models for use at intermittent pressures higher than 8000 psi (560 bar).

Ordering a PF500 Series pump requires a complete model code specifying shaft, seal and outlet port options. Refer to "Typical Model Code" on page 6.

Maximum Pressure

The intermittent pressures listed in the table are the maximum pressures a pump can sustain for occasional, short periods of operation without appreciably reducing life expectancy.

Fluid Guidelines

See page 42 for "Fluid Recommendations".

Some pump models may require reduced operating pressures when using low-lubricity fluids.

Because of the wide range of fluid characteristics, contact the sales department for a review of any application using non-petroleum based fluids.

Split-Flow® Provides Multiple Outlets

PF500 models with split-flow covers efficiently supply flows for multiple function circuits. Piston outputs are grouped together in the cover, with various piston flow splits available in this four-piston pump. Refer to "Typical Model Code" on page 6 and contact the sales department for availability.

Reduced Output Option

Pump output can be reduced by one-half by deactivating two pistons. Refer to "Typical Model Code" on page 6.

Typical Performance Curves

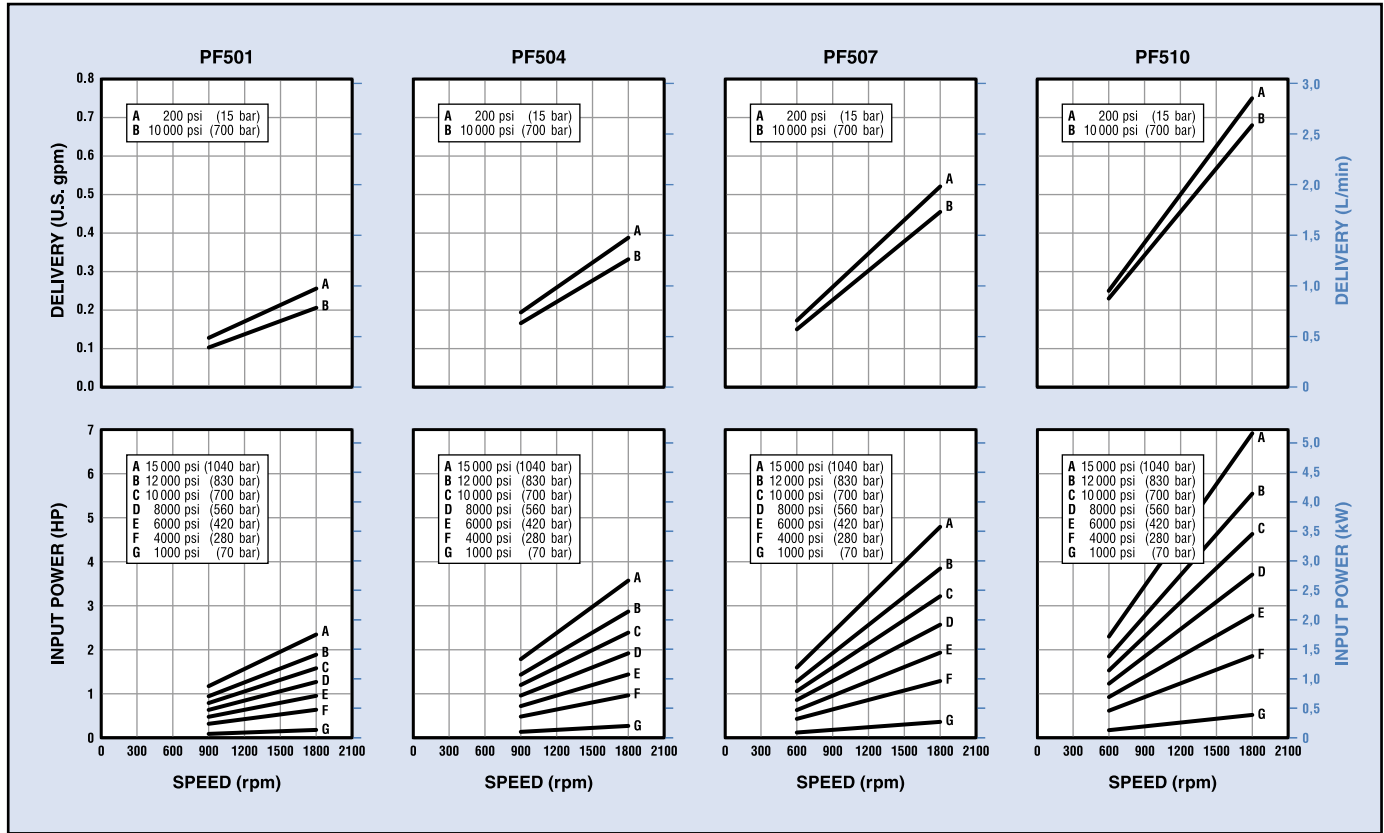

Typical performance curves are based on 100 SUS (20 cSt) mineral oil with pressurized inlet where required. Refer to the "Minimum Inlet Pressure" table on page 4. Contact the sales department for applications requiring continuous duty operation at speeds higher or lower than shown.

INSTALLATION

All dimensions are shown in inches (millimeters in parentheses) and are nominal. Refer to Bulletin PSI.CB for general installation and operating recommendations.

The drawing shows dimensions common to all PF500 models. Note that the location of the outlet port varies as shown, dependent on the type of port. Refer to "Outlet Port

Configurations" on page 43 and "Typical Model Code" on page 6 to specify port.

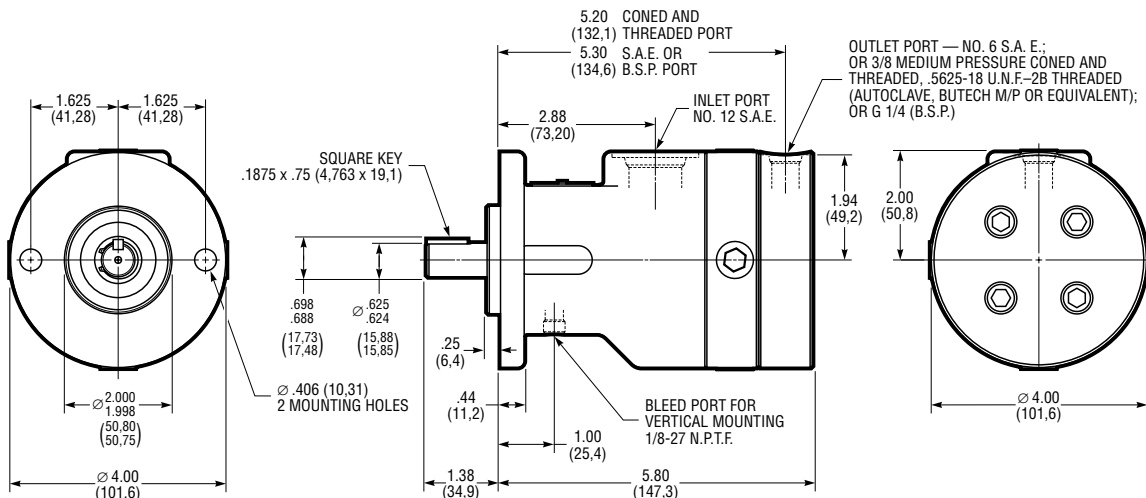

PF500 SERIES

TYPICAL MODEL CODE

PF5

01

H - XV

A

-

22 - 1

0

Pump Type	
PF5	Fixed Displacement Checkball Pump

Output Flow (At 1800 rpm, at rated pressure) ^①	
01	0.21 gpm (0.79 L/min)
04	0.33 gpm (1.25 L/min)
07	0.46 gpm (1.74 L/min)
10	0.68 gpm (2.57 L/min)

^① Output flows based on typical performance at rated pressure. Refer to performance curves for flows at lower pressures.

Operating Pressure	
No Code	Standard Pressure
H	High Pressure ^①

^① Requires "A" or "B" port option.

Seals	
No Code	Fluorocarbon (Viton® or Fluorel®) Seals with Buna-N (Nitrile) Shaft Seal
XE	All EPR with High Pressure Shaft Seal ^①
XV	All Fluorocarbon (Viton® or Fluorel®) with High Pressure Shaft Seal

^① Not available with High Pressure "H" option. Contact the sales department for recommended operating conditions.

Ports	
No Code	Inlet No. 12 S.A.E.; Outlet No. 6 S.A.E. ^①
A	Inlet No. 12 S.A.E.; Outlet 3/8 Medium Pressure Coned and Threaded, 0.5625-18 U.N.F.-2B Threaded ^②
B	Inlet No. 12 S.A.E.; Outlet G 1/4 (B.S.P.) ^③

^① Not recommended for operation above 8000 psi (560 bar). Contact the fitting manufacturer for the pressure rating of the fitting.
^② High pressure port uses Autoclave Medium Pressure, Butech M/P or equivalent fitting.
^③ Outlet port uses British Standard Pipe fitting. Not recommended for operation above 10 000 psi (700 bar).

Design Number

Modification Number

Split-Flow® Options (4 Piston Pump) ^①	
No Code	Full flow from single outlet
<i>Split-Flow® Cover Models:</i>	
22	Two-pistons output + Two-pistons output
31	Three-pistons output + One-piston output ^②
4X	Four ports, each with one-piston output
2	Two pistons output + Two inactive pistons

^① For outlet port sizes, locations and pump cover dimensions, contact the sales department.
^② Port for output flow designated by first digit is located at the 12 o'clock position (for code "31", three-piston output flow exits the 12 o'clock port).

PF1000 SERIES



PUMP DESCRIPTION

Fixed displacement checkball pumps, with bi-directional shaft rotation, provide constant direction of output flow regardless of the direction of drive shaft rotation.

Mounting

S.A.E. A 2-bolt pattern with 0.25 inch (6,4 mm) pilot engagement.

Shaft Options

Standard keyed shaft, 0.875 inch (22.20 mm) diameter;

Optional spline shaft, 0.873/0.872 inch diameter standard S.A.E. 13 tooth, 16/32 D.P. 30° involute spline.

Outlet Port Options

Standard pressure models have S.A.E. ports. The high pressure "H" option requires the use of outlet port option "A" (Autoclave Medium Pressure, Butech M/P or equivalent fittings), or outlet port option "B" (British Standard Pipe fittings).

Inlet Conditions

Pumps may require pressurized inlet conditions at higher speeds. Failure to meet minimum inlet requirements will result in slight flow reduction. Refer to the table.

Seal Options

Standard seals are Buna-N (Nitrile). Options include Fluorocarbon (Viton® or Fluorel®), or EPR for use with some phosphate ester fluids.

Weight (Mass)

30 lb (14 kg)

Specifications

Pump Models	Output Flow at 1500 rpm ^①		Output Flow at 1800 rpm ^①		Rated Pressure		Maximum Intermittent Pressure		Rated Speed rpm ^②	Maximum Speed rpm ^②
	U.S. gpm	L/min	U.S. gpm	L/min	psi	bar	psi	bar		
PF1002-10	1.2	4,7	1.5	5,7	6000	420	8000	560	1800	3600
PF1003-10	1.7	6,6	2.1	7,9	6000	420	8000	560	1800	3600
PF1004-10	2.1	8,2	2.6	9,8	6000	420	8000	560	1800	3600
PF1005-10	2.9	11,0	3.5	13,2	6000	420	8000	560	1800	2800
PF1006-10	3.4	12,9	4.1	15,5	6000	420	8000	560	1800	2800
PF1007-10	4.1	15,7	5.0	18,9	4000	280	6000	420	1800	2800
PF1008-10	4.9	18,6	5.9	22,3	4000	280	6000	420	1800	2800
PF1002H-10	1.2	4,7	1.5	5,7	6000	420	10 000	700	1800	3600
PF1003H-10	1.7	6,6	2.1	7,9	6000	420	10 000	700	1800	3600
PF1004H-10	2.1	8,2	2.6	9,8	6000	420	10 000	700	1800	3600
PF1005H-10	2.9	11,0	3.5	13,2	6000	420	10 000	700	1800	2800
PF1006H-10	3.4	12,9	4.1	15,5	6000	420	10 000	700	1800	2800

① Output flow based on typical performance at rated pressure with pressurized inlet where required, as shown in the table below.

② Contact the sales department for applications requiring operation above rated speed. High speed operation may require a pressurized inlet. Refer to "Inlet Conditions".

Minimum Inlet Pressure^①

Pump Models	Operating Speed							
	1800 rpm		2200 rpm		2800 rpm		3600 rpm	
	psi	bar	psi	bar	psi	bar	psi	bar
PF1002	0	0	0	0	0	0	5	0,4
PF1003 and PF1004	0	0	0	0	5	0,4	10 ^②	0,7 ^②
PF1005, PF1006, PF1007 and PF1008	0	0	5	0,4	10 ^②	0,7 ^②	–	–

① Values shown are based on fluid viscosity of 100 SUS (20 cSt).

② Inlet pressures higher than 10 psig (0,7 bar) require a high-pressure shaft seal. Refer to "Typical Model Code" on page 9 for seal options.

PUMP SELECTION

The table shows specifications for standard pressure and high pressure "H" option models.

Ordering a PF1000 Series, 10 Design, pump requires a complete model code specifying shaft, seal and outlet port options. Refer to "Typical Model Code" on page 9.

Maximum Pressure

Checkball pumps are especially suited for applications susceptible to excessive pressure spikes.

The intermittent pressures listed are the maximum pressures a pump can sustain for occasional, short periods of operation without appreciably reducing life expectancy.

Fluid Guidelines

See page 42 for "Fluid Recommendations".

Some pump models may require reduced operating pressures when using low-lubricity fluids.

Because of the wide range of fluid characteristics, contact the sales department for a review of any application using non-petroleum based fluids.

Split-Flow® Provides Multiple Outlets

PF1000 models with split-flow covers efficiently supply flows for multiple function circuits. Piston outputs are grouped together in the cover, with various piston flow splits available in this four-piston pump. Refer to "Typical Model Code" on page 9 and contact the sales department for availability.

PF1000 SERIES

Typical Performance Curves

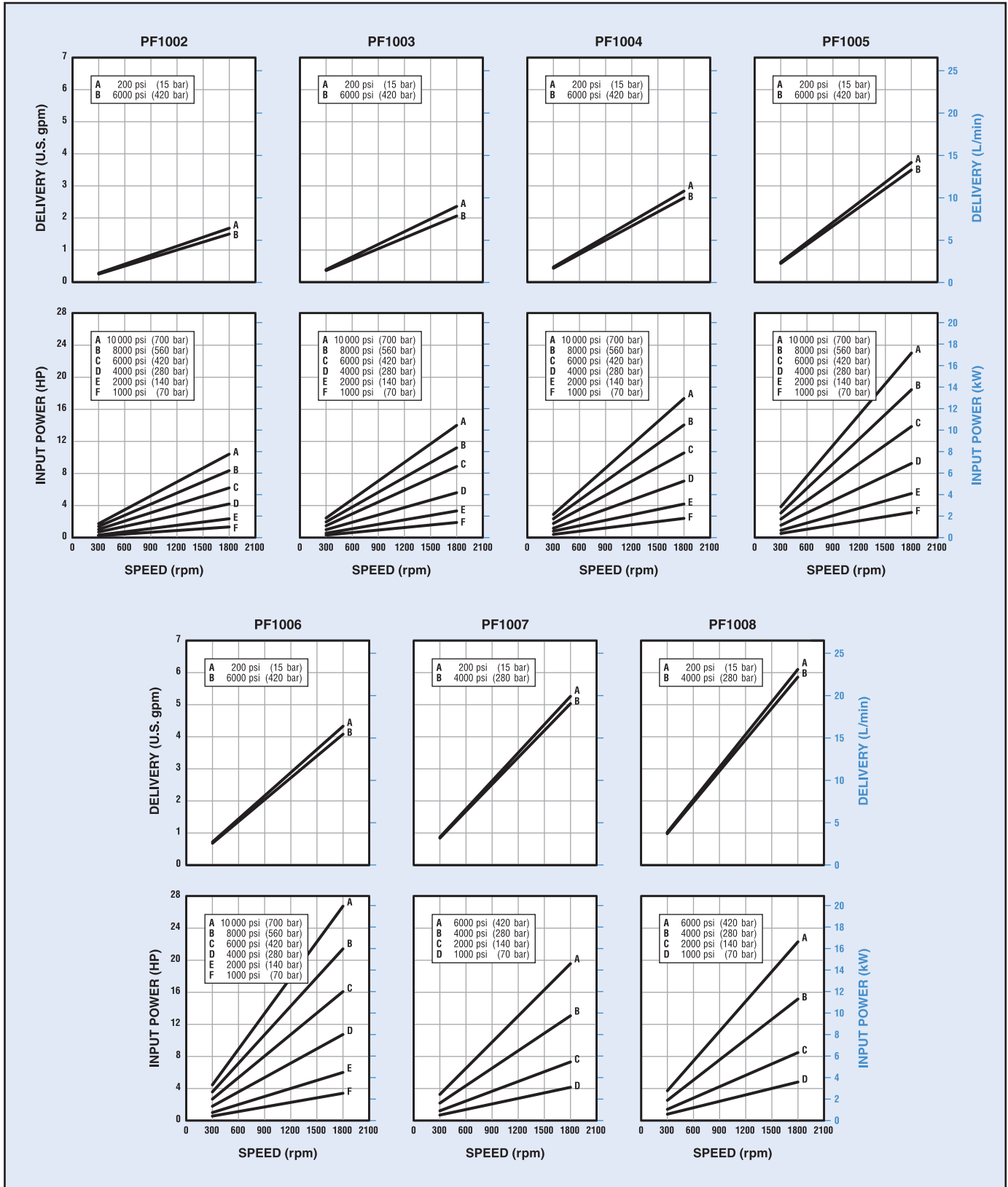

Typical performance curves are based on 100 SUS (20 cSt) mineral oil with pressurized inlet where required. Refer to the "Minimum Inlet Pressure" table on page 7.

PF1000 SERIES

INSTALLATION

All dimensions are shown in inches (millimeters in parentheses) and are nominal. See page 7 for spline shaft data. Refer to Bulletin PSI.CB for general installation and operating recommendations.

The drawing shows dimensions common to all PF1000 models. Note that the dimension for the outlet port varies as shown, dependent on the type of port. Refer to

“Outlet Port Configurations” on page 43 and “Typical Model Code” below to specify port.

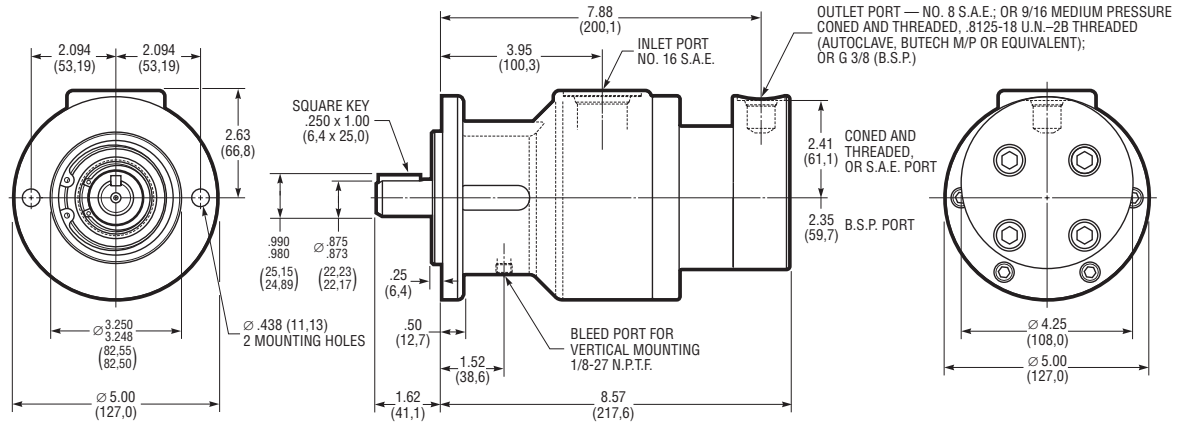

TYPICAL MODEL CODE

PF10 02 H - S XV A - 22 - 1 0

Pump Type	
PF10	Fixed Displacement Checkball Pump

Output Flow (At 1800 rpm, at rated pressure) ^①	
02	1.5 gpm (5,7 L/min)
03	2.1 gpm (7,9 L/min)
04	2.6 gpm (9,8 L/min)
05	3.5 gpm (13,2 L/min)
06	4.1 gpm (15,5 L/min)
07	5.0 gpm (18,9 L/min) ^②
08	5.9 gpm (22,3 L/min) ^②

① Output flows based on typical performance at rated pressure. Refer to performance curves for flows at lower pressures.
② Not available with high pressure "H" option.

Operating Pressure	
No Code	Standard Pressure
H	High Pressure ^①

① Requires "A" or "B" port option.

Drive Shaft	
No Code	Keyed, 0.875 inch (22,20 mm) diameter
S	S.A.E. Spline, 0.875 inch (22,20 mm)

Ports	
No Code	Inlet No. 16 S.A.E.; Outlet No. 8 S.A.E. ^①
A	Inlet No. 16 S.A.E.; Outlet 9/16 Medium Pressure Coned and Threaded, 0.8125-16 U.N.-2B Threaded ^②
B	Inlet No. 16 S.A.E.; Outlet G 3/8 (B.S.P.) ^③

① Not recommended for operation above 8000 psi (560 bar). Contact the fitting manufacturer for the pressure rating of the fitting.
② High pressure port uses Autoclave Medium Pressure, Butech M/P or equivalent fitting.
③ Outlet port uses British Standard Pipe fitting. Not recommended for operation above 10 000 psi (700 bar).

Split-Flow [®] Options (4 Piston Pump) ^①	
No Code	Full flow from single outlet
Split-Flow [®] Cover Models:	
22	Two-pistons output + Two-pistons output
31	Three-pistons output + One-piston output
4X	Four ports, each with one-piston output
2	Two pistons output + Two inactive pistons

① For outlet port sizes, locations and pump cover dimensions, contact the sales department.

Seals	
No Code	All Buna-N (Nitrile) ^①
XE	All EPR with High Pressure Shaft Seal ^①
XV	All Fluorocarbon (Viton [®] or Fluorel [®]) with High Pressure Shaft Seal

① Not available with High Pressure "H" option. Contact the sales department for recommended operating conditions.

Design Number
22 - 1

Modification Number
0



PUMP DESCRIPTION

Fixed displacement checkball pumps, with bi-directional shaft rotation, provide constant direction of output flow regardless of the direction of drive shaft rotation.

Mounting

S.A.E. B 2-bolt pattern with 0.25 inch (6,4 mm) pilot engagement.

Shaft Options

Standard keyed shaft, 0.875 inch (22.22 mm) diameter;

Optional spline shaft, 0.873/0.872 inch diameter standard S.A.E. 13 tooth, 16/32 D.P. 30° involute spline. Contact the sales department for model number.

Outlet Port Options

Standard pressure models have S.A.E. ports. High pressure models use either coned and threaded fittings (Autoclave Medium Pressure, Butech M/P or equivalent), or B.S.P. fittings (British Standard Pipe).

Inlet Conditions

Pumps may require pressurized inlet conditions at higher speeds. Failure to meet minimum inlet requirements will result in slight flow reduction. Refer to the table.

Seal Options

Standard seals are Buna-N (Nitrile). Contact the sales department for other seal options.

Weight (Mass)

30 lb (14 kg)

Specifications

Pump Models	Output Flow at 1500 rpm ^①		Output Flow at 1800 rpm ^①		Rated Pressure		Maximum Intermittent Pressure		Rated Speed rpm	Maximum Speed rpm
	U.S. gpm	L/min	U.S. gpm	L/min	psi	bar	psi	bar		
<i>S.A.E. Ports:</i>										
PF2007-2190	3.4	12,9	4.1	15,5	6000	420	6000	420	2000	2800
PF2008-2191	4.8	18,3	5.8	22,0	5000	350	6000	420	2000	2400
PF2009-2184	5.1	19,2	6.1	23,1	3000	210	4000	280	2000	2800
PF2012-2185	7.1	26,8	8.5	32,2	3000	210	4000	280	2000	2400
<i>Coned and Threaded Outlet Port:^②</i>										
PF2007-2973	3.4	12,9	4.1	15,5	6000	420	10 000	700	1800	2800
<i>B.S.P. Outlet Port:^③</i>										
PF2007-3055	3.4	12,9	4.1	15,5	6000	420	10 000	700	1800	2800

① Output flow based on typical performance at rated pressure with pressurized inlet where required, as shown in the table below.

② High pressure outlet port uses Autoclave Medium Pressure, Butech M/P or equivalent fitting.

③ Outlet port uses British Standard Pipe fitting.

Minimum Inlet Pressures^①

Pump Models	Operating Speed					
	2000 rpm		2400 rpm		2800 rpm	
	psi	bar	psi	bar	psi	bar
PF2007	0	0	3	0,2	5	0,4
PF2008	0	0	5	0,4	–	–
PF2009	0	0	3	0,2	5	0,4
PF2012	0	0	5	0,4	–	–

① Values shown are based on fluid viscosity of 100 SUS (20 cSt). Inlet pressures higher than 10 psig (0,7 bar) require a high-pressure shaft seal.

PUMP SELECTION

The “Specifications” table lists the most commonly used standard models with keyed shafts. Contact the sales department for models with spline shafts, optional seals and other extraordinary operating requirements.

Maximum Pressure

Checkball pumps are especially suited for applications susceptible to excessive pressure spikes.

The intermittent pressures listed are the maximum pressures a pump can sustain for occasional, short periods of operation without appreciably reducing life expectancy.

Fluid Guidelines

See page 42 for “Fluid Recommendations”.

Some pump models may require reduced operating pressures when using low-lubricity fluids.

Because of the wide range of fluid characteristics, contact the sales department for a review of any application using non-petroleum based fluids.

Split-Flow® Provides Multiple Outlets

PF2000 models with split-flow covers efficiently supply flows for multiple function circuits. Piston outputs are grouped together in the cover, with various piston flow splits available in this six-piston pump. Contact the sales department for Split-Flow® options and availability.

Typical Performance Curves

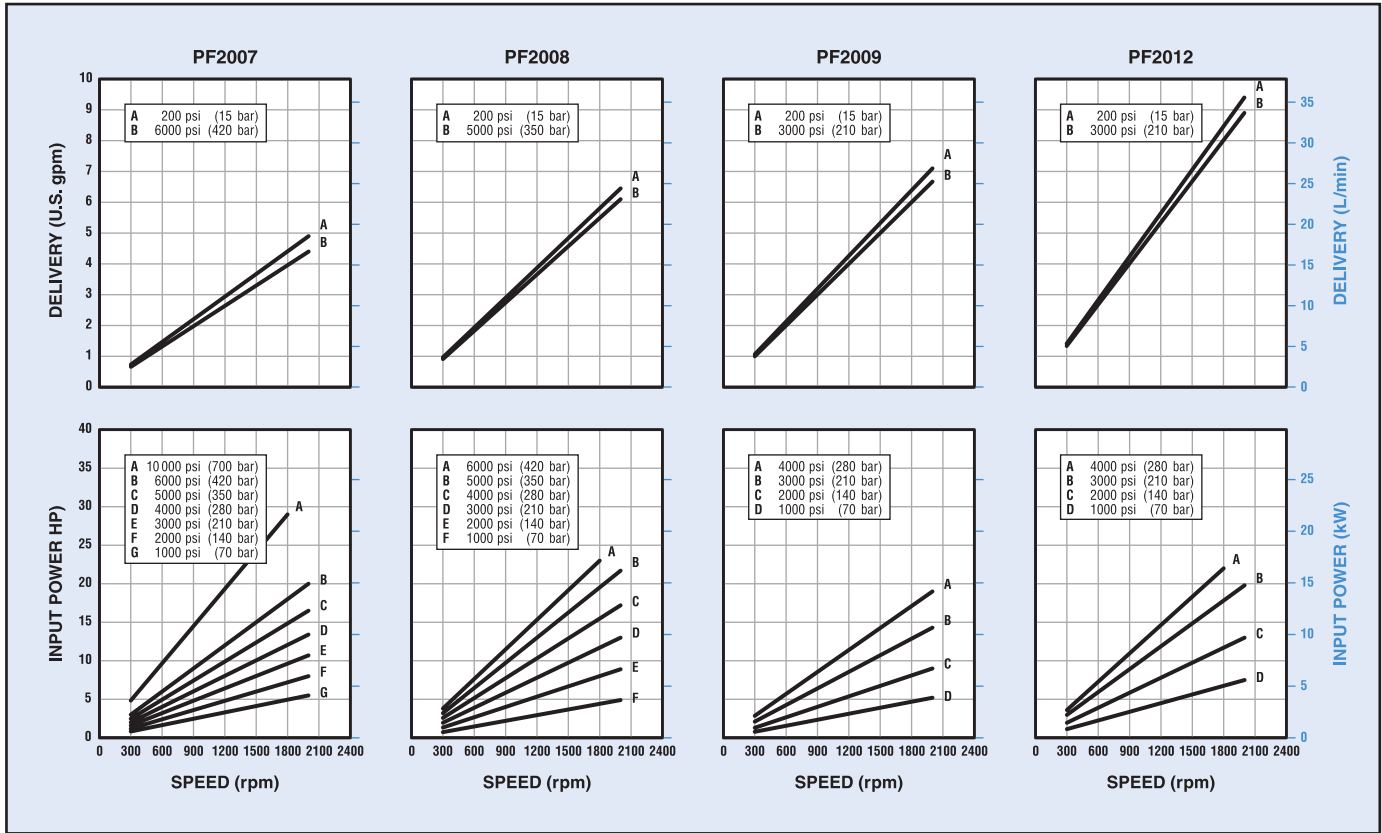

Typical performance curves are based on 100 SUS (20 cSt) mineral oil with pressurized inlet where required. Refer to the "Minimum Inlet Pressure" table on page 10.

INSTALLATION

All dimensions are shown in inches (millimeters in parentheses) and are nominal. See page 10 for optional spline shaft data. Refer to Bulletin PSI.CB for general installation and operating recommendations.

The diameter of the pump cover and the location of the outlet port varies as shown, dependent on the model. The port location for high-pressure models is shown printed in gray. This port uses either a coned and

threaded (Autoclave or Butech) fitting or a B.S.P. (British Standard Pipe) fitting. Refer to "Outlet Port Configurations" on page 43 and the "Specifications" table on page 10 for model numbers to specify port.

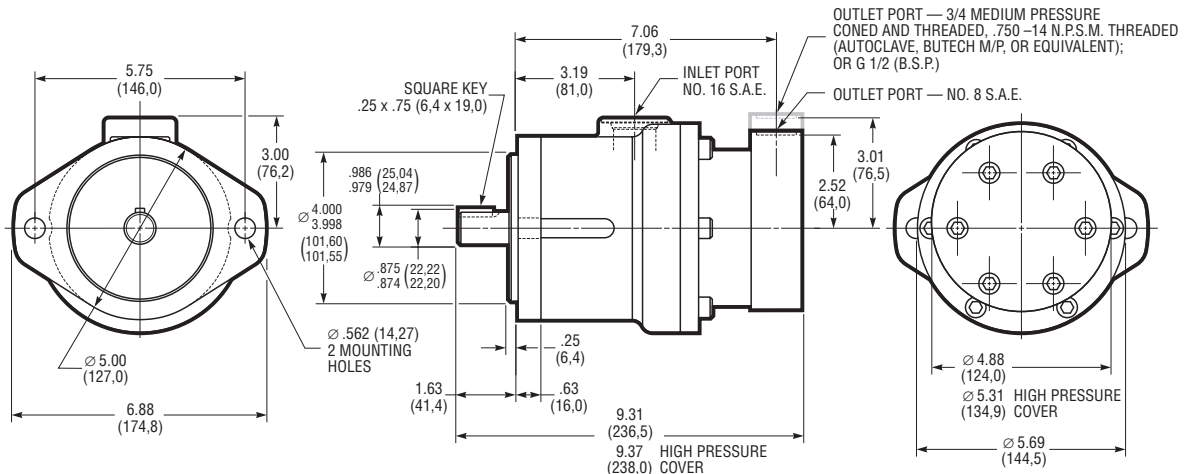

PF2000 SERIES SPECIAL MOUNTING



PUMP DESCRIPTION

Fixed displacement checkball pumps, with bi-directional shaft rotation, provide constant direction of output flow regardless of the direction of drive shaft rotation.

Mounting

Special 4-bolt pattern. Refer to installation drawing.

Shaft

Available with 1.25 inch (31,75 mm) diameter keyed shaft.

Outlet Port Options

Available with S.A.E. or N.P.T.F. ports. Refer to the "Specifications" table.

Inlet Conditions

Pumps may require pressurized inlet conditions at higher speeds. Failure to meet minimum inlet requirements will result in slight flow reduction. Refer to the table.

Seal Options

Standard seals are Buna-N (Nitrile). Contact the sales department for other seal options.

Weight (Mass)

43 lb (20 kg)

Specifications

Pump Models	Output Flow at 1500 rpm ^①		Output Flow at 1800 rpm ^①		Rated Pressure		Maximum Intermittent Pressure		Rated Speed rpm	Maximum Speed rpm
	U.S. gpm	L/min	U.S. gpm	L/min	psi	bar	psi	bar		
<i>S.A.E. Ports:</i>										
PF2006-1808	3.3	12,6	4.0	15,1	6000	420	8000	560	2000	2400
PF2008-1804	4.7	18,0	5.7	21,6	3000	210	5000	350	2000	2400
<i>N.P.T.F. Ports:</i>										
PF2006-1807	3.3	12,6	4.0	15,1	6000	420	8000	560	2000	2400
PF2008-1802	4.7	18,0	5.7	21,6	3000	210	5000	350	2000	2400

^① Output flow based on typical performance at rated pressure with pressurized inlet where required, as shown in the "Minimum Inlet Pressure" table.

Minimum Inlet Pressure^①

Pump Models	Operating Speed			
	2000 rpm		2400 rpm	
	psi	bar	psi	bar
All PF2000 Models (Special Mounting)	0	0	5	0,4

^① Values shown are based on fluid viscosity of 100 SUS (20 cSt). Inlet pressures higher than 10 psig (0,7 bar) require a high-pressure shaft seal.

PUMP SELECTION

The "Specifications" table lists the most commonly used standard models with keyed shafts. Contact the sales department for models with optional seals and other extraordinary operating requirements.

Maximum Pressure

Checkball pumps are especially suited for applications susceptible to excessive pressure spikes.

The intermittent pressures listed are the maximum pressures a pump can sustain for occasional, short periods of operation without appreciably reducing life expectancy.

Fluid Guidelines

See page 42 for "Fluid Recommendations".

Some pump models may require reduced operating pressures when using low-lubricity fluids.

Because of the wide range of fluid characteristics, contact the sales department for a review of any application using non-petroleum based fluids.

Split-Flow® Provides Multiple Outlets

These PF2000 Series pumps can efficiently supply flows for multiple function circuits.

Split-Flow® models are available with isolator valves installed into the pump, to separate one or more pistons from the main outlet. Up to six independent outlet flows are possible from this six-piston pump.

When using isolator valves, high-pressure models are limited to a maximum pressure of 6000 psi (420 bar).

Contact the sales department for Split-Flow® model numbers.

PF2000 SERIES SPECIAL MOUNTING

Typical Performance Curves

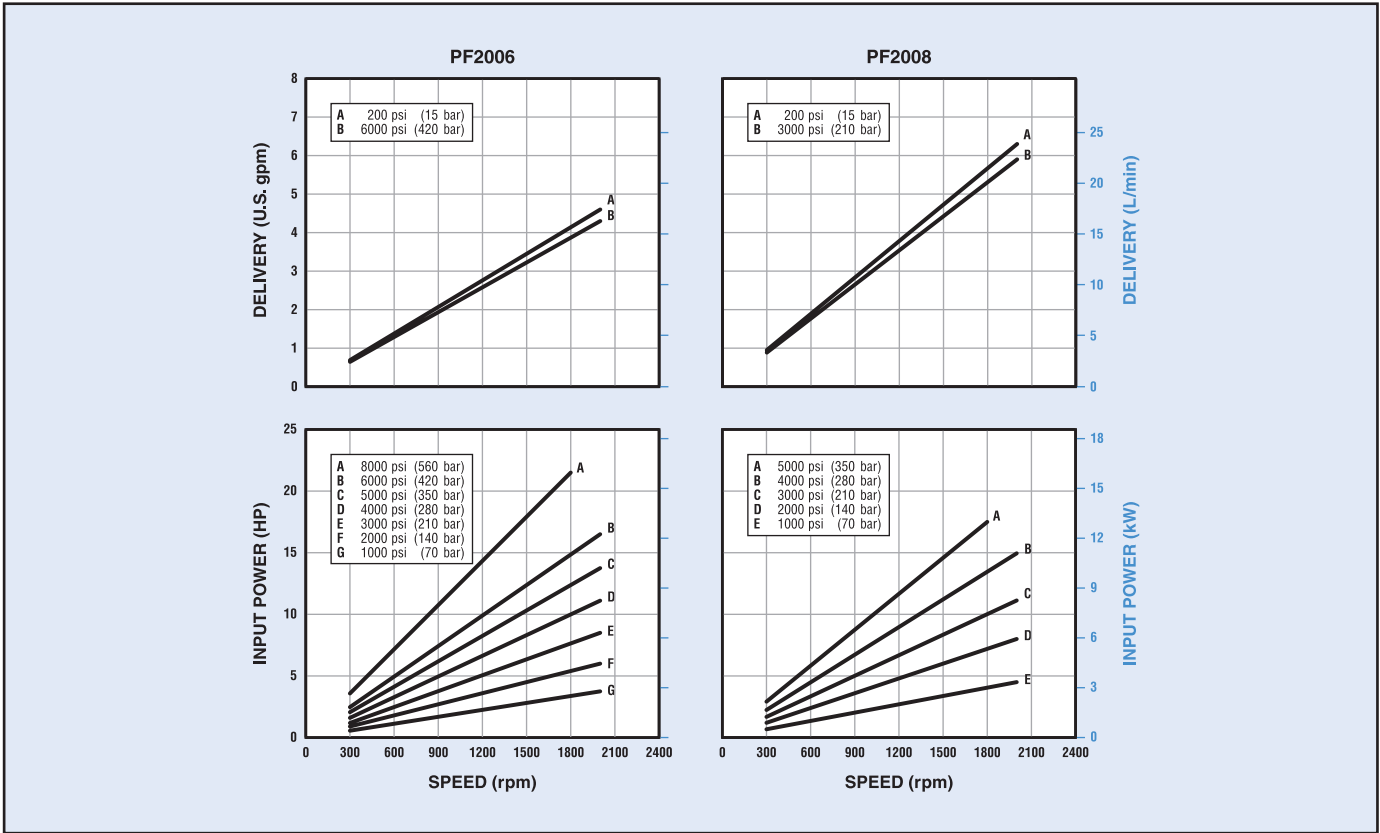

Typical performance curves are based on 100 SUS (20 cSt) mineral oil with pressurized inlet where required. Refer to the "Minimum Inlet Pressure" table on page 12.

INSTALLATION

All dimensions are shown in inches (millimeters in parentheses) and are nominal.

These PF2000 Series models have a special 4-bolt mounting pattern shown below.

Refer to Bulletin PSI.CB for general installation and operating recommendations.

Refer to "Outlet Port Configurations" on page 43 and the "Specifications" table on page 12 for model numbers to specify ports.

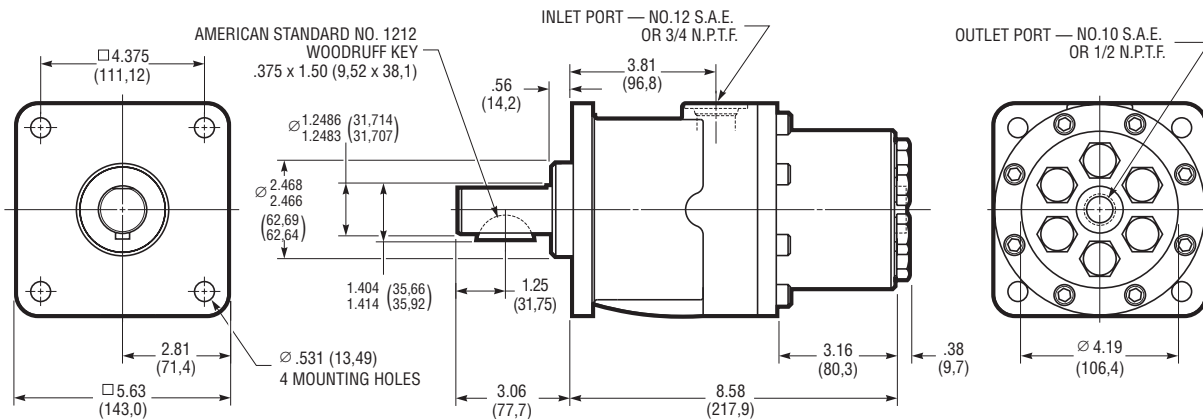



Specifications

Pump Models	Output Flow at 1500 rpm ^①		Output Flow at 1800 rpm ^①		Rated Pressure		Maximum Intermittent Pressure		Rated Speed rpm ^②	Maximum Speed rpm ^②
	U.S. gpm	L/min	U.S. gpm	L/min	psi	bar	psi	bar		
PF3011-10	6.7	25,5	8.1	30,7	6000	420	8000	560	1800	2800
PF3015-10	8.3	31,5	10.0	37,8	6000	420	8000	560	1800	2500
PF3017-10	10.0	37,8	12.0	45,4	6000	420	8000	560	1800	2200
PF3021-10	12.0	45,4	14.4	54,5	4000	280	6000	420	1800	2500
PF3024-10	14.3	54,2	17.2	65,1	4000	280	6000	420	1800	2200
PF3011H-10	6.7	25,5	8.1	30,7	6000	420	10 000	700	1800	2800
PF3015H-10	8.3	31,5	10.0	37,8	6000	420	10 000	700	1800	2500

- ① Output flow based on typical performance at rated pressure with pressurized inlet where required, as shown in the table below.
- ② Contact the sales department for applications requiring operation above rated speed. High speed operation may require a pressurized inlet. Refer to "Inlet Conditions".

PUMP DESCRIPTION

Fixed displacement checkball pumps, with bi-directional shaft rotation, provide constant direction of output flow regardless of the direction of drive shaft rotation.

Mounting

S.A.E. C 4-bolt pattern with 0.25 inch (6,4 mm) pilot engagement.

Shaft Options

Standard keyed shaft, 1.250 inch (31,75 mm) diameter;

Optional spline shaft, 1.248/1.247 inch diameter standard S.A.E. 14 tooth, 12/24 D.P. 30° involute spline.

Outlet Port Options

Standard pressure models have S.A.E. ports. The high pressure "H" option requires the use of outlet port option "A" (Autoclave Medium Pressure, Butech M/P or equivalent fittings), or outlet port option "B" (British Standard Pipe fittings).

Inlet Conditions

Pumps may require pressurized inlet conditions at higher speeds. Failure to meet minimum inlet requirements will result in slight flow reduction. Refer to the table.

Seal Options

Standard seals are Buna-N (Nitrile). Options include Fluorocarbon (Viton® or Fluorel®), or EPR for use with some phosphate ester fluids.

Weight (Mass)

62 lb (28 kg)

Minimum Inlet Pressure^①

Pump Models	Operating Speed									
	1500 rpm		1800 rpm		2200 rpm		2500 rpm		2800 rpm	
	psi	bar	psi	bar	psi	bar	psi	bar	psi	bar
PF3011	0	0	0	0	5	0,4	7	0,5	10 ^②	0,7 ^②
PF3015	0	0	3	0,2	7	0,5	10 ^②	0,7 ^②	–	–
PF3017	0	0	5	0,4	10	0,7	–	–	–	–
PF3021	0	0	3	0,2	7	0,5	10 ^②	0,7 ^②	–	–
PF3024	0	0	5	0,4	10	0,7	–	–	–	–

① Values shown are based on fluid viscosity of 100 SUS (20 cSt).

② Inlet pressures higher than 10 psig (0,7 bar) require a high-pressure shaft seal. Refer to "Typical Model Code" on page 16 for seal options.

PUMP SELECTION

The table shows specifications for standard pressure and high pressure "H" option models.

Ordering a PF3000 Series, 10 Design, pump requires a complete model code specifying shaft, seal and outlet port options. Refer to "Typical Model Code" on page 16.

Maximum Pressure

Checkball pumps are especially suited for applications susceptible to excessive pressure spikes.

The intermittent pressures listed are the maximum pressures a pump can sustain for occasional, short periods of operation without appreciably reducing life expectancy.

Fluid Guidelines

See page 42 for "Fluid Recommendations".

Some pump models may require reduced operating pressures when using low-lubricity fluids.

Because of the wide range of fluid characteristics, contact the sales department for a review of any application using non-petroleum based fluids.

Split-Flow® Provides Multiple Outlets

PF3000 models with split-flow covers efficiently supply flows for multiple function circuits. Piston outputs are grouped together in the cover, with various piston flow splits available in this eight-piston pump. Refer to "Typical Model Code" on page 16 and contact the sales department for availability.

PF3000 SERIES

Typical Performance Curves

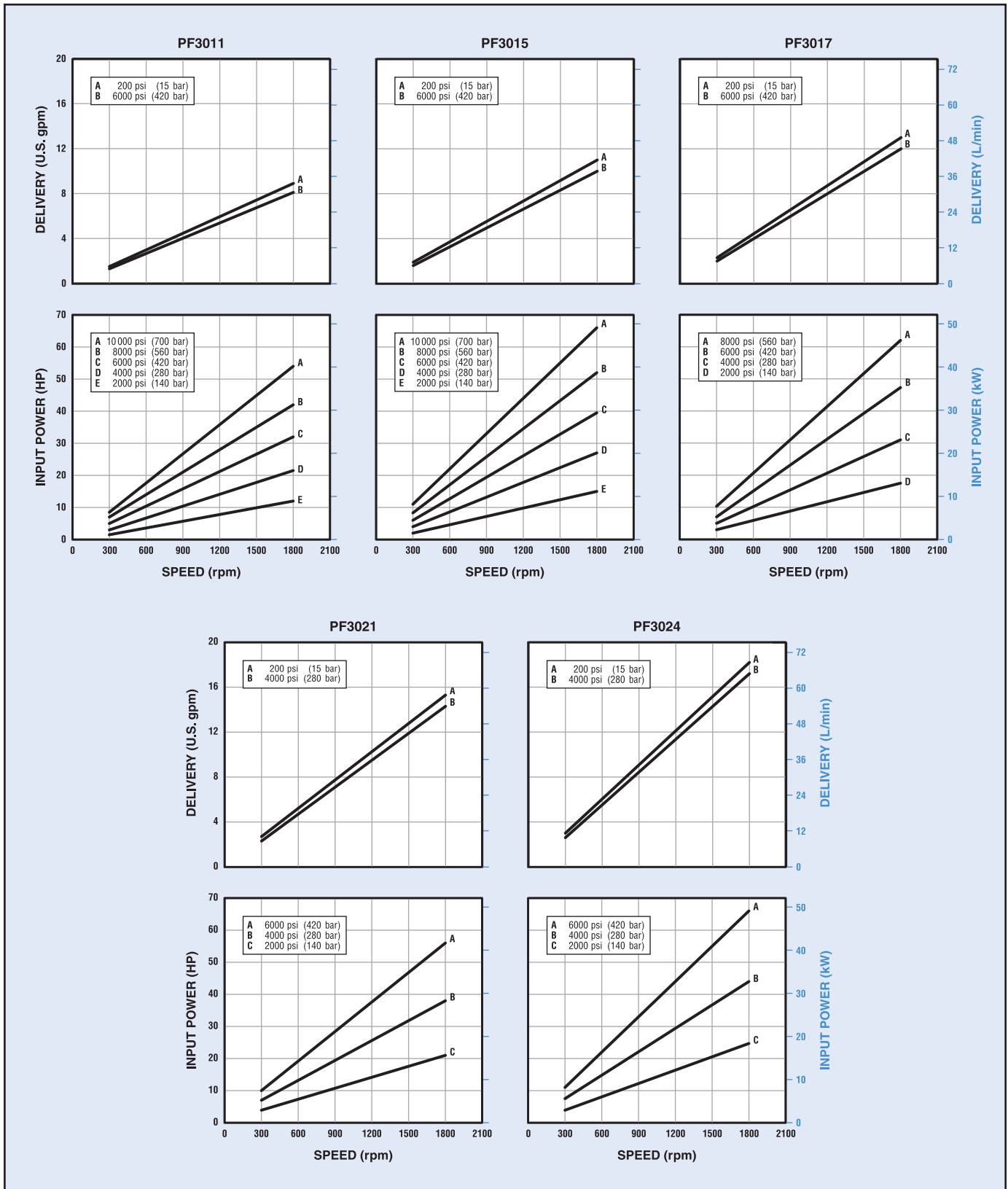

Typical performance curves are based on 100 SUS (20 cSt) mineral oil with pressurized inlet where required. Refer to "Minimum Inlet Pressure" table on page 14.

PF3000 SERIES

INSTALLATION

All dimensions are shown in inches (millimeters in parentheses) and are nominal.

See page 14 for spline shaft data.

Refer to Bulletin PSI.CB for general installation and operating recommendations.

The drawing shows dimensions common to all PF3000 models. Note that the location of

the outlet port varies as shown, dependent on the type of port. Refer to "Outlet Port Configurations" on page 43 and "Typical Model Code" below to specify port.

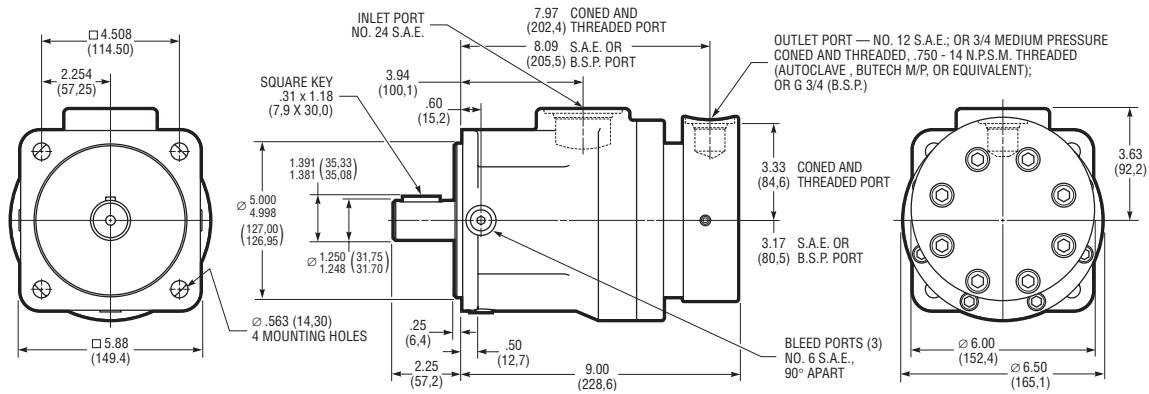

TYPICAL MODEL CODE

PF30 11 H - S XV A - 44 - 1 0

Pump Type	
PF30	Fixed Displacement Checkball Pump

Output Flow (At 1800 rpm, at rated pressure) ^①	
11	8.1 gpm (30,7 L/min)
15	10.0 gpm (37,8 L/min)
17	12.0 gpm (45,4 L/min) ^②
21	14.4 gpm (54,5 L/min) ^②
24	17.2 gpm (65,1 L/min) ^②

① Output flows based on typical performance at rated pressure. Refer to performance curves for flows at lower pressures.
② Not available with high pressure "H" option.

Operating Pressure	
No Code	Standard Pressure
H	High Pressure ^①

① Requires "A" or "B" port option.

Drive Shaft	
No Code	Keyed, 1.250 inch (31,75 mm) diameter
S	S.A.E. Spline, 1.250 inch (31,75 mm)

Ports	
No Code	Inlet No. 24 S.A.E.; Outlet No. 12 S.A.E. ^①
A	Inlet No. 24 S.A.E.; Outlet 3/4 Medium Pressure Coned and Threaded, 3/4-14 N.P.S.M. Threaded ^②
B	Inlet No. 24 S.A.E.; Outlet G 3/4 (B.S.P.) ^③

① Not recommended for operation above 8000 psi (560 bar). Contact the fitting manufacturer for the pressure rating of the fitting.
② High pressure port uses Autoclave Medium Pressure, Butech M/P or equivalent fitting.
③ Outlet port uses British Standard Pipe fitting. Not recommended for operation above 10 000 psi (700 bar).

Split-Flow [®] Options (8 Piston Pump) ^①	
No Code	Full flow from single outlet
Split-Flow [®] Cover Models:	
44	Four-pistons output + Four-pistons output
53	Five-pistons output + Three-pistons output
62	Six-pistons output + Two-pistons output
71	Seven-pistons output + One-piston output
8X	Eight ports, each with one-piston output
4	Four pistons output + Four inactive pistons

① For outlet port sizes, locations and pump cover dimensions, contact the sales department.

Seals	
No Code	All Buna-N (Nitrile) ^①
XE	All EPR with High Pressure Shaft Seal ^①
XV	All Fluorocarbon (Viton [®] or Fluorel [®]) with High Pressure Shaft Seal

① Not available with High Pressure "H" option. Contact the sales department for recommended operating conditions.

Design Number
44 - 1

Modification Number
0



PUMP DESCRIPTION

Fixed displacement checkball pumps, with bi-directional shaft rotation, provide constant direction of output flow regardless of the direction of drive shaft rotation.

Mounting

S.A.E. D 4-bolt pattern with 0.25 inch (6,4 mm) pilot engagement.

Shaft Options

Standard keyed shaft, 1.250 inch (31,75 mm) diameter;

Optional spline shaft, 1.248/1.247 inch diameter standard S.A.E. 14 tooth, 12/24 D.P. 30° involute spline.

Outlet Port Options

Standard pressure models have S.A.E. ports. High pressure "H" option models require the use of outlet port option "A" (Autoclave Medium Pressure, Butech M/P or equivalent fittings), or outlet port option "B" (British Standard Pipe fittings).

Refer to "Outlet Port Configurations" on page 43 and "Typical Model Code" on page 19 to specify outlet port.

Inlet Conditions

Pumps may require pressurized inlet conditions at higher speeds. Failure to meet minimum inlet requirements will result in slight flow reduction. Refer to the table.

Seal Options

Standard seals are Buna-N (Nitrile). Options include Fluorocarbon (Viton® or Fluorel®) or EPR for use with some phosphate ester fluids.

Weight (Mass)

111 lb (50 kg)

Specifications

Pump Models	Output Flow at 1500 rpm ^①		Output Flow at 1800 rpm ^①		Rated Pressure		Maximum Intermittent Pressure		Rated Speed rpm ^②	Maximum Speed rpm ^②
	U.S. gpm	L/min	U.S. gpm	L/min	psi	bar	psi	bar		
PF4011-30	6.4	24,2	7.7	29,1	6000	420	8000	560	1800	2400
PF4016-30	9.2	35,0	11.1	42,0	6000	420	8000	560	1800	2400
PF4018-30	10.3	39,1	12.4	46,9	6000	420	8000	560	1800	2400
PF4020-30	11.6	44,1	14.0	53,0	6000	420	8000	560	1800	2400
PF4011H-30	6.0	23,0	7.3	27,6	10 000	700	10 000	700	1800	2400
PF4016H-30	8.7	33,1	10.5	39,7	10 000	700	10 000	700	1800	2400
PF4018H-30	10.0	38,1	12.1	45,8	8000	560	10 000	700	1800	2400
PF4020H-30	11.4	43,2	13.7	51,9	8000	560	10 000	700	1800	2400

① Output flow based on typical performance at rated pressure with pressurized inlet where required, as shown in the table below.

② Contact the sales department for applications requiring operation above rated speed. High speed operation may require a pressurized inlet. Refer to "Inlet Conditions".

Minimum Inlet Pressure^①

Pump Models	Operating Speed							
	1200 rpm		1500 rpm		1800 rpm		2400 rpm	
	psi	bar	psi	bar	psi	bar	psi	bar
PF4011	0	0	0	0	0	0	5	0,4
PF4016	0	0	0	0	0	0	5	0,4
PF4018	0	0	0	0	5	0,4	10 ^②	0,7 ^②
PF4020	0	0	5	0,4	10 ^②	0,7 ^②	15 ^②	1,0 ^②

① Values shown are based on fluid viscosity of 100 SUS (20 cSt).

② Inlet pressures higher than 10 psig (0,7 bar) require a high-pressure shaft seal. Refer to "Typical Model Code" on page 19 for seal options.

PUMP SELECTION

The table shows specifications for standard pressure and high pressure "H" option models.

Ordering a PF4000 Series, 10 Design, pump requires a complete model code specifying shaft, seal and outlet port options. Refer to "Typical Model Code" on page 19.

Maximum Pressure

Checkball pumps are especially suited for applications susceptible to excessive pressure spikes.

The intermittent pressures listed are the maximum pressures a pump can sustain for occasional, short periods of operation without appreciably reducing life expectancy.

Fluid Guidelines

See page 42 for "Fluid Recommendations".

Some pump models may require reduced operating pressures when using low-lubricity fluids.

The optional "Low Lubricity Kit" provides an additional internal passage for improved bearing lubrication when using low-lubricity fluids. Refer to "Typical Model Code" on page 19.

Because of the wide range of fluid characteristics, contact the sales department for a review of any application using non-petroleum based fluids.

Split-Flow® Provides Multiple Outlets

PF4000 models with split-flow covers efficiently supply flows for multiple function circuits. Piston outputs are grouped together in the cover, with various piston flow splits available in this ten-piston pump. Refer to "Typical Model Code" on page 19 and contact the sales department for availability.

PF4000 SERIES

Typical Performance Curves

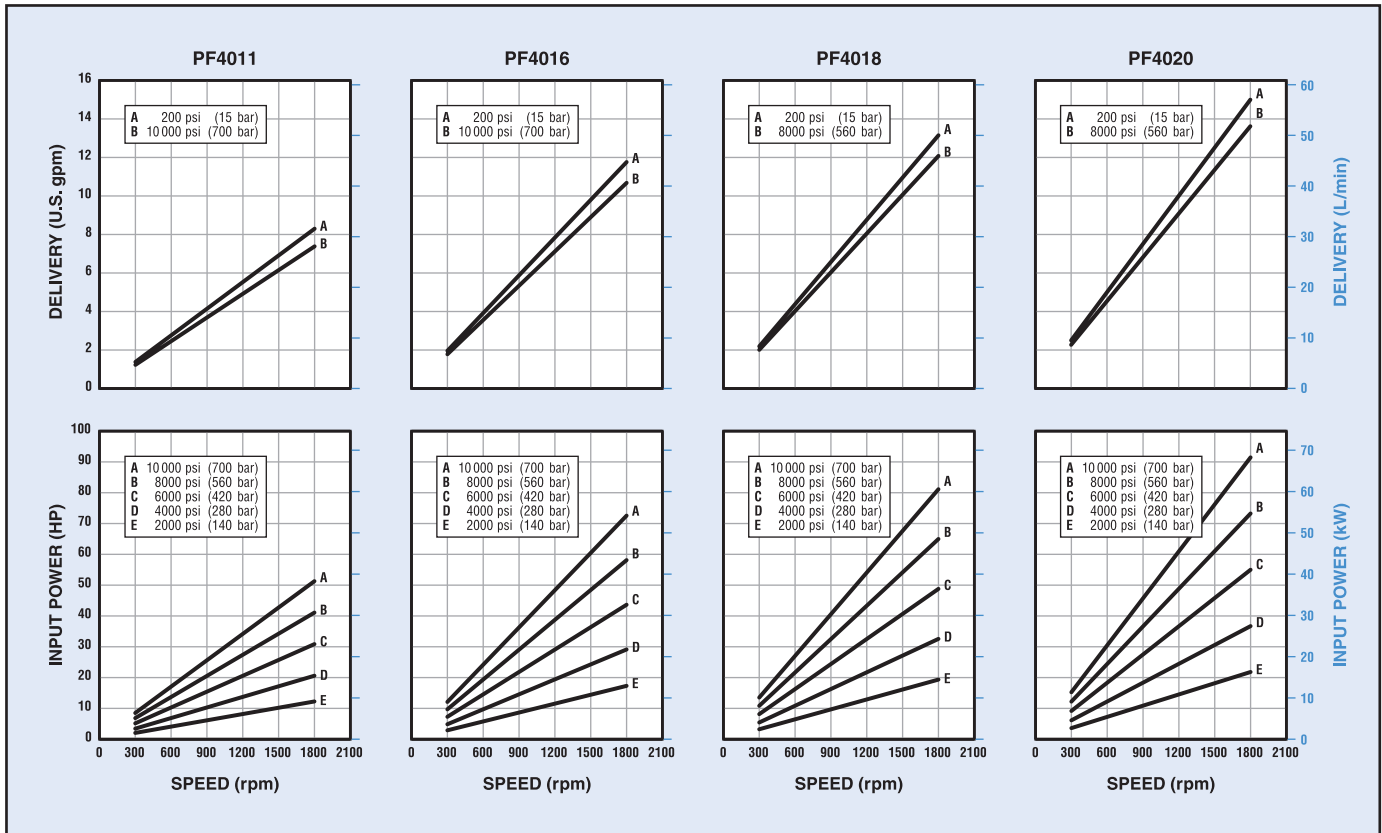

Typical performance curves are based on 100 SUS (20 cSt) mineral oil with pressurized inlet where required. Refer to the "Minimum Inlet Pressure" table on page 17.

INSTALLATION

All dimensions are shown in inches (millimeters in parentheses) and are nominal. See page 17 for spline shaft data. Refer to Bulletin PSI.CB for general installation and operating recommendations.

The thickness of the cover and the location of the outlet port varies as shown, dependent on the port option.

Variable Dimensions

Variable Dimension	Outlet Port Option			
	S.A.E. or B.S.P Port		Coned and Threaded	
	Models PF4011, PF4016	Models PF4018, PF4020	Models PF4011, PF4016	Models PF4018, PF4020
A	8.59 (218,2)	8.66 (220,0)	8.46 (214,9)	8.53 (216,7)
B	3.94 (100,2)	3.94 (100,2)	4.09 (103,8)	4.09 (103,8)
C	9.49 (241,1)	9.56 (242,9)	9.49 (241,1)	9.56 (242,9)

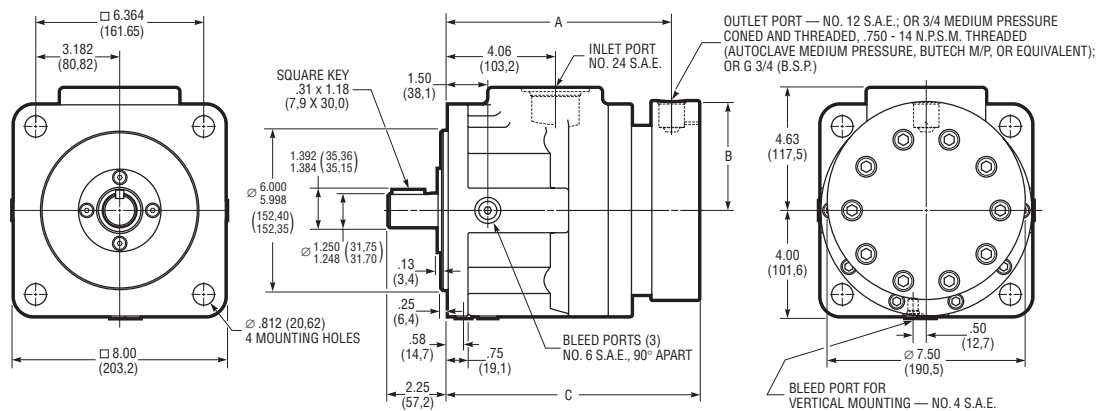

PF4000 SERIES

TYPICAL MODEL CODE

PF40 11 H – S XV A L – 55 – 3 0

Pump Type	
PF40	Fixed Displacement Checkball Pump

Output Flow (At 1800 rpm, at rated pressure) ^①	
11	Standard: 7.7 gpm (29,1 L/min) "H" Option: 7.3 gpm (27,6 L/min)
16	Standard: 11.1 gpm (42,0 L/min) "H" Option: 10.5 gpm (39,7 L/min)
18	Standard: 12.4 gpm (46,9 L/min) "H" Option: 12.1 gpm (45,8 L/min)
20	Standard: 14.0 gpm (53,0 L/min) "H" Option: 13.7 gpm (51,9 L/min)

^① Output flows based on typical performance at rated pressure. Refer to performance curves for flows at lower pressures.

Operating Pressure	
No Code	Standard Pressure
H	High Pressure ^①

^① Requires "A" or "B" port option.

Drive Shaft	
No Code	Keyed, 1.250 inch (31,75 mm) diameter
S	S.A.E. Spline, 1.250 inch (31,75 mm)

Seals	
No Code	All Buna-N (Nitrile) ^①
XE	All EPR with High Pressure Shaft Seal ^①
XV	All Fluorocarbon (Viton [®] or Fluorel [®]) with High Pressure Shaft Seal

^① Not available with High Pressure "H" option. Contact the sales department for recommended operating conditions.

Options	
No Code	Standard
L	Low Lubricity Kit ^①

^① Provides an additional internal passage for improved bearing lubrication when using low-lubricity fluids.

Design Number

Modification Number

Ports	
No Code	Inlet No. 24 S.A.E.; Outlet No. 12 S.A.E. ^①
A	Inlet No. 24 S.A.E.; Outlet 3/4 Medium Pressure Coned and Threaded, 3/4-14 N.P.S.M. Threaded ^②
B	Inlet No. 24 S.A.E.; Outlet G 3/4 (B.S.P.) ^③

^① Not recommended for operation above 8000 psi (560 bar). Contact the fitting manufacturer for the pressure rating of the fitting.
^② High pressure port uses Autoclave Medium Pressure, Butech M/P or equivalent fitting.
^③ Outlet port uses British Standard Pipe fitting. Not recommended for operation above 10 000 psi (700 bar).

Split-Flow [®] Options (10 Piston Pump) ^①	
No Code	Full flow from single outlet
<i>Split-Flow[®] Cover Models:</i>	
55	Five-pistons output + Five-pistons output
64	Six-pistons output + Four-pistons output
73	Seven-pistons output + Three-pistons output
82	Eight-pistons output + Two-pistons output
91	Nine-pistons output + One-piston output
10X	Ten ports, each with one-piston output
5	Five pistons output + Five inactive pistons

^① For outlet port sizes, locations and pump cover dimensions, contact the sales department.

PF4200 SERIES

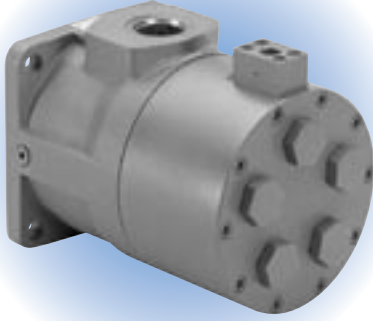

PUMP DESCRIPTION

These fixed displacement high-pressure checkball pumps are capable of intermittent pressures to 20 000 psi (1380 bar).

They are compatible with a wide range of fluids including diesel calibration fluid, Skydrol and other phosphate ester fluids, various military fluids, and other low-viscosity or low-lubricity fluids.

Bi-directional shaft rotation provides constant direction of output flow regardless of the direction of drive shaft rotation.

Mounting

S.A.E. D 4-bolt pattern with 0.25 inch (6,4 mm) pilot engagement.

Shaft Options

Standard keyed shaft, 1.250 inch (31,75 mm) diameter;

Optional spline shaft, 1.248/1.247 inch diameter standard S.A.E. 14 tooth, 12/24 D.P. 30° involute spline.

Outlet Port Options

Standard pressure models have S.A.E. ports. High pressure "H" option models require the use of outlet port option "A" (Autoclave Medium Pressure, Butech M/P or equivalent fittings), or outlet port option "B" (British Standard Pipe fittings).

Inlet Conditions

Pumps may require pressurized inlet conditions at higher speeds. Failure to meet minimum inlet requirements will result in slight flow reduction. Refer to the table.

Seal Options

Options include Fluorocarbon (Viton® or Fluorel®) or EPR for use with some phosphate ester fluids.

Specifications^①

Pump Models	Output Flow at 1500 rpm ^②		Output Flow at 1800 rpm ^②		Rated Pressure		Maximum Intermittent Pressure		Rated Speed rpm ^③	Maximum Speed rpm ^③
	U.S. gpm	L/min	U.S. gpm	L/min	psi	bar	psi	bar		
PF4203-10	1.8	6,9	2.2	8,3	8000	560	8000	560	1800	1800
PF4205-10	3.0	11,4	3.6	13,6	8000	560	8000	560	1800	1800
PF4208-10	4.3	16,4	5.2	19,7	8000	560	8000	560	1800	1800
PF4209-10	4.9	18,6	5.9	22,3	8000	560	8000	560	1800	1800
PF4210-10	5.6	21,1	6.7	25,4	8000	560	8000	560	1800	1800
PF4203H-10	1.5	5,9	1.9	7,2	15 000	1040	20 000	1380	1800	1800
PF4205H-10	2.6	10,0	3.2	12,1	15 000	1040	20 000	1380	1800	1800
PF4208H-10	4.0	15,4	4.9	18,5	12 000	830	17 000	1170	1800	1800
PF4209H-10	4.6	17,6	5.6	21,2	12 000	830	17 000	1170	1800	1800
PF4210H-10	5.4	20,4	6.5	24,6	10 000	700	15 000	1040	1800	1800

① Specifications are based on the use of mineral oil operating within proper viscosity guidelines. Refer to "Fluid Guidelines" below and on page 42.

② Output flow based on typical performance at rated pressure with pressurized inlet where required, as shown in the table.

③ Contact the sales department for applications requiring operation above maximum speed.

Minimum Inlet Pressure^①

Pump Models	Operating Speed					
	1200 rpm		1500 rpm		1800 rpm	
	psi	bar	psi	bar	psi	bar
PF4203	0	0	0	0	0	0
PF4205	0	0	0	0	0	0
PF4208	0	0	0	0	5	0,4
PF4209	0	0	5	0,4	10	0,7
PF4210	0	0	5	0,4	10	0,7

① Values shown are based on fluid viscosity of 100 SUS (20 cSt).

High pressure shaft seals are standard on all PF4200 Series models.

Weight (Mass)

140 lb (64 kg)

PUMP SELECTION

The table shows specifications for standard pressure and high pressure "H" option models. Refer to "Typical Model Code" on page 22 to specify shaft, seal and outlet port options.

Maximum Pressure

Checkball pumps are especially suited for applications susceptible to excessive pressure spikes.

The intermittent pressures listed are the maximum pressures a pump can sustain for occasional, short periods of operation without appreciably reducing life expectancy.

Fluid Guidelines

See page 42 for "Fluid Recommendations".

Some pump models may require reduced operating pressures when using low-lubricity fluids.

Because of the wide range of fluid characteristics, contact the sales department for a review of any application using non-petroleum based fluids.

PF4200 SERIES

Typical Performance Curves

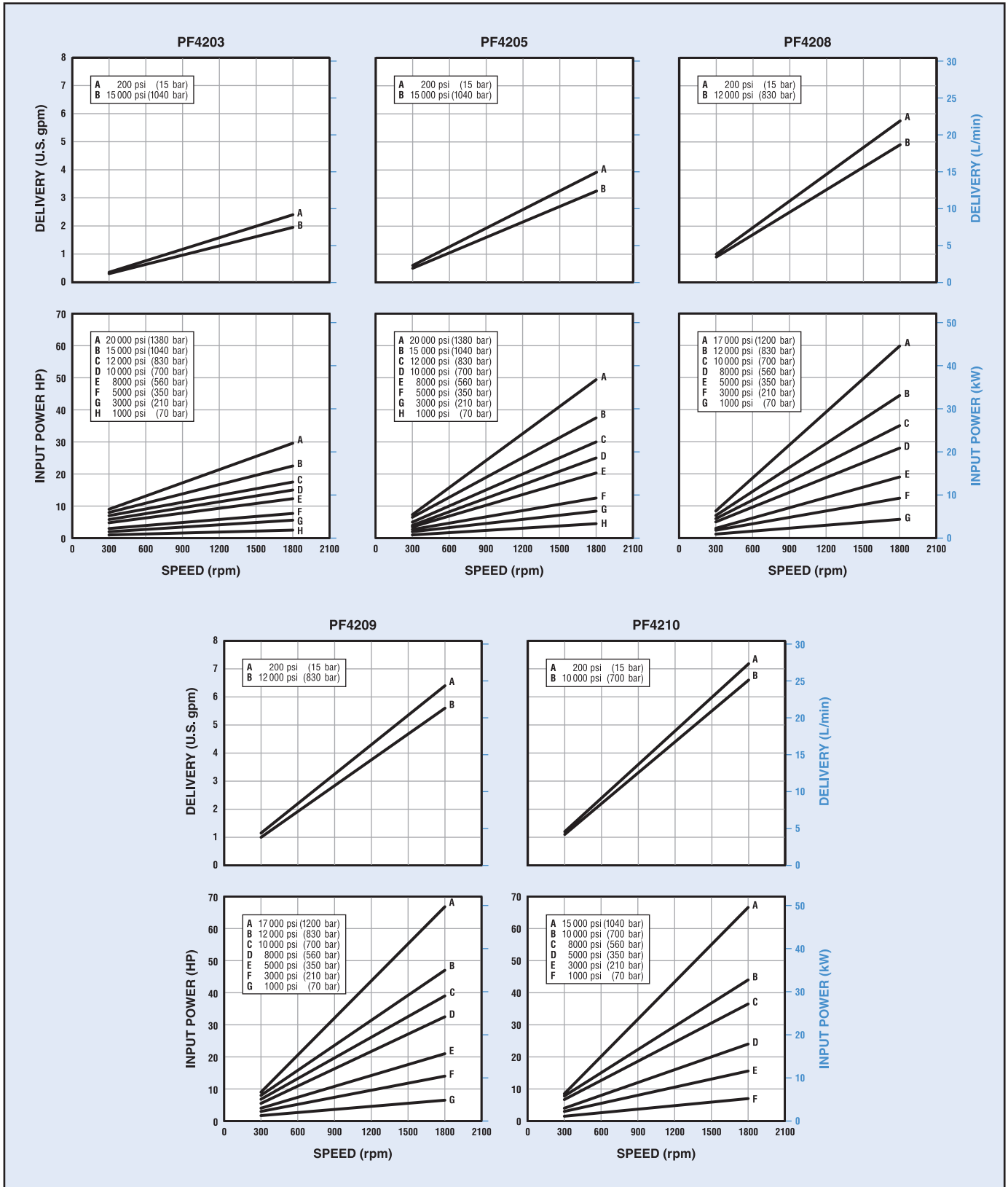

Typical performance curves are based on 100 SUS (20 cSt) mineral oil with pressurized inlet where required. Refer to the "Minimum Inlet Pressure" table on page 20.

PF4200 SERIES

INSTALLATION

All dimensions are shown in inches (millimeters in parentheses) and are nominal. See page 20 for spline shaft data. Refer to Bulletin PSI.CB for general installation and operating recommendations.

The drawing shows dimensions common to all PF4200 Series pumps. Note, however, that Model PF4203 has three pistons, rather than five.

As shown, the outlet port on these pumps is machined in a block integrally mounted to the pump barrel. Refer to "Outlet Port Configurations" on page 43 and "Typical Model Code" below to specify the port.

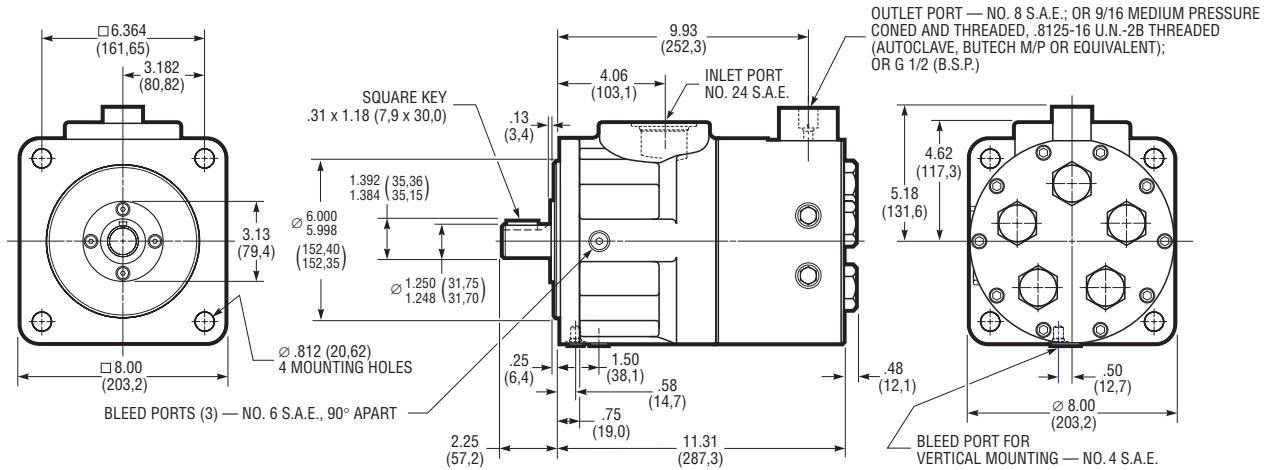

TYPICAL MODEL CODE

PF42 03 H - S XE A - 1 0

Pump Type		Ports		Design Number	Modification Number
PF42	Fixed Displacement Checkball Pump	No Code	Inlet No. 24 S.A.E.; Outlet No. 8 S.A.E. ^①		
Output Flow (At 1800 rpm, at rated pressure)^{①②}		A	Inlet No. 24 S.A.E.; Outlet 9/16 Medium Pressure Coned and Threaded, .8125-16 U.N.-2B Threaded ^②		
03	Standard: 2.2 gpm (8,3 L/min) "H" Option: 1.9 gpm (7,2 L/min)	B	Inlet No. 24 S.A.E.; Outlet G 1/2 (B.S.P.) ^③		
05	Standard: 3.6 gpm (13,6 L/min) "H" Option: 3.2 (12,1 L/min)	^① Not recommended for operation above 8000 psi (560 bar). Contact the fitting manufacturer for the pressure rating of the fitting. ^② High pressure port uses Autoclave Medium Pressure, Butech M/P or equivalent fitting. ^③ Outlet port uses British Standard Pipe fitting. Not recommended for operation above 10 000 psi (700 bar).			
08	Standard: 5.2 gpm (19,7 L/min) "H" Option: 4.9 gpm (18,5 L/min)	Seals			
09	Standard: 5.9 gpm (22,3 L/min) "H" Option: 5.6 gpm (21,2 L/min)	XE	All EPR with High Pressure Shaft Seal ^①		
10	Standard: 6.7 gpm (25,4 L/min) "H" Option: 6.5 gpm (24,6 L/min)	XV	All Fluorocarbon (Viton® or Fluorel®) with High Pressure Shaft Seal		
^① Output flows based on typical performance at rated pressure. Refer to performance curves for flows at lower pressures. ^② Model PF4203 has three pistons; other models have five pistons.		^① Contact the sales department for recommended operating conditions for any application using non-petroleum based fluids.			
Operating Pressure		Drive Shaft			
No Code	Standard Pressure	No Code	Keyed, 1.250 inch (31,75 mm) diameter		
H	High Pressure ^①	S	S.A.E. Spline, 1.250 inch (31,75 mm)		
^① Requires "A" or "B" port option.					

PF4300 SERIES



PUMP DESCRIPTION

These fixed displacement checkball pumps are compatible with a variety of water-based fluids. Bi-directional shaft rotation provides constant direction of output flow regardless of the direction of drive shaft rotation.

Single-Fluid Lubrication Design

The checkball design uses the pumped fluid for internal bearing lubrication. This eliminates the potential for fluid cross-contamination, possible in other designs with isolated lubrication. It also avoids the cost of a separate lubrication circuit.

These pumps are ideal for use in wellhead safety control systems, other subsea applications, industrial equipment including hydroform presses, and other applications requiring fire-resistant fluids.

Mounting

S.A.E. D 4-bolt pattern with 0.25 inch (6,4 mm) pilot engagement.

Shaft Options

Standard keyed shaft, 1.250 inch (31,75 mm) diameter;

Optional spline shaft, 1.248/1.247 inch diameter standard S.A.E. 14 tooth, 12/24 D.P. 30° involute spline.

Outlet Port Options

Standard pressure models have S.A.E. ports. High pressure "H" option models require the use of outlet port option "A" (Autoclave Medium Pressure, Butech M/P or equivalent fittings), or outlet port option "B" (British Standard Pipe fittings).

Inlet Conditions

Pumps may require pressurized inlet conditions at higher speeds. Failure to meet

Specifications

Pump Models	Output Flow at 1200 rpm ^①		Output Flow at 1500 rpm ^①		Output Flow at 1800 rpm ^①		Maximum Pressure		Rated Speed rpm ^②	Maximum Speed rpm ^②
	U.S. gpm	L/min	U.S. gpm	L/min	U.S. gpm	L/min	psi	bar		
PF4303-11	1.5	5,6	1.8	6,9	2.2	8,3	8000	560	1200	1800
PF4304-11	2.1	8,1	2.7	10,1	3.2	12,1	8000	560	1200	1800
PF4305-11	2.5	9,3	3.1	11,7	3.7	14,0	8000	560	1200	1800
PF4306-11	3.1	11,6	3.8	14,5	4.6	17,4	8000	560	1200	1800
PF4308-11	3.6	13,6	4.5	17,0	5.4	20,4	8000	560	1200	1800
PF4309-11	4.0	15,1	5.0	18,9	6.0	22,7	8000	560	1200	1800
PF4310-11	4.5	17,1	5.7	21,4	6.8	25,7	8000	560	1200	1800
PF4312-11	5.5	20,7	6.8	25,9	8.2	31,0	8000	560	1200	1800
PF4303H-11	1.3	4,8	1.6	6,2	2.0	7,5	15 000	1040	1200	1800
PF4304H-11	2.0	7,6	2.5	9,5	3.1	11,7	12 000	830	1200	1800
PF4305H-11	2.3	8,9	2.9	11,0	3.6	13,6	10 000	700	1200	1800
PF4306H-11	2.9	11,1	3.7	13,9	4.4	16,6	10 000	700	1200	1800
PF4308H-11	3.5	13,2	4.3	16,5	5.3	19,9	10 000	700	1200	1800
PF4309H-11	3.9	14,7	4.8	18,2	5.9	22,3	10 000	700	1200	1800
PF4310H-11	4.4	16,7	5.5	21,0	6.7	25,3	10 000	700	1200	1800
PF4312H-11	5.4	20,4	6.7	25,6	8.1	30,7	10 000	700	1200	1800

① Output flow based on typical performance using water glycol fluid at maximum pressure with pressurized inlet where required, as shown in the table below.

② Contact the sales department for operation above the rated speed of 1200 rpm.

Minimum Inlet Pressure^①

Pump Models	Operating Speed					
	1200 rpm		1500 rpm		1800 rpm	
	psi	bar	psi	bar	psi	bar
PF4303, PF4304, PF4305 and PF4306	0	0	0	0	0	0
PF4308	0	0	0	0	5	0,4
PF4309	0	0	5	0,4	10	0,7
PF4310	0	0	5	0,4	15	1,0
PF4312	0	0	5	0,4	15	1,0

① Values shown are based on fluid viscosity of 33 SUS (1,9 cSt).

minimum inlet requirements will result in slight flow reduction. Refer to the table.

Standard Seals

Fluorocarbon (Viton® or Fluorel®) with high-pressure shaft seal.

Weight (Mass)

116 lb (53 kg)

PUMP SELECTION

The table shows specifications for standard pressure and high pressure "H" option models. Refer to "Typical Model Code" on page 25 to specify shaft and outlet port options.

Maximum Pressure

The maximum pressures listed are the highest pressures a pump can sustain for occasional, short periods of operation without appreciably reducing life expectancy.

Special Fluid Operation

Because of the wide range of water-based fluid characteristics, contact the sales department for a review of any application using non-petroleum based fluids.

PF4300 SERIES

Typical Performance Curves

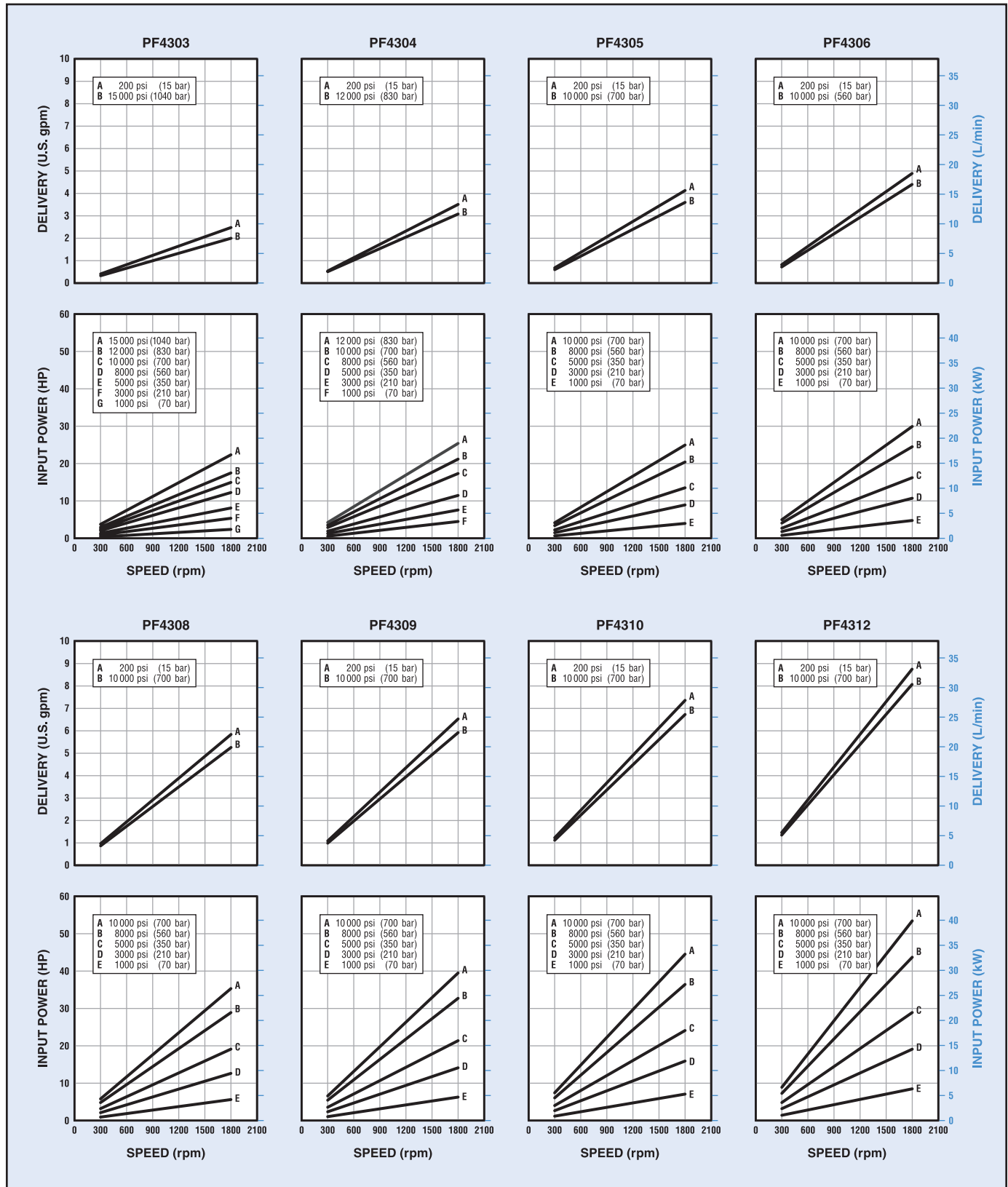

Typical performance curves are based on 33 SUS (1,9 cSt) water glycol fluid with pressurized inlet where required. Refer to the "Minimum Inlet Pressure" table on page 23.

PF4300 SERIES

INSTALLATION

All dimensions are shown in inches (millimeters in parentheses) and are nominal. See page 23 for spline shaft data. Refer to Bulletin PSI.CB for general installation and operating recommendations.

Note that Models PF4303 and PF4304 have three pistons; Models PF4305, PF4308, PF4309 and PF4310 have five pistons; and Models PF4306 and PF4312 have six pistons.

As shown, the outlet port on these pumps is machined in a block integrally mounted to the pump barrel. Refer to "Outlet Port Configurations" on page 43 and "Typical Model Code" below to specify the port.

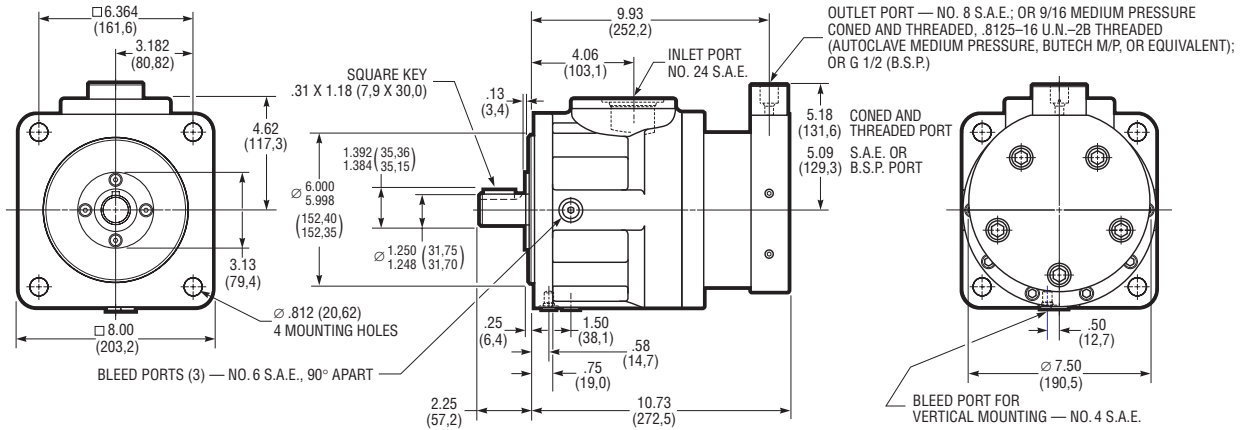

TYPICAL MODEL CODE

PF43 03 H - S XV A - 1 1

Pump Type		Ports		Design Number	Modification Number
PF43	Fixed Displacement Checkball Pump	No Code	Inlet No. 24 S.A.E.; Outlet No. 8 S.A.E. ^①	1	1
		A	Inlet No. 24 S.A.E.; Outlet 9/16 Medium Pressure Coned and Threaded, .8125-16 U.N.-2B Threaded ^②		
		B	Inlet No. 24 S.A.E.; Outlet G 1/2 (B.S.P.) ^③		
Output Flow (At 1800 rpm, at maximum pressure)^{①②}		Seals			
03	Standard: 2.2 gpm (8,3 L/min) "H" Option: 2.0 gpm (7,5 L/min)	XV	All Fluorocarbon (Viton® or Fluorel®) with High Pressure Shaft Seal		
04	Standard: 3.2 gpm (12,1 L/min) "H" Option: 3.1 gpm (11,7 L/min)	Drive Shaft			
05	Standard: 3.7 gpm (14,0 L/min) "H" Option: 3.6 gpm (13,6 L/min)	No Code	Keyed, 1.250 inch (31,75 mm) diameter		
06	Standard: 4.6 gpm (17,4 L/min) "H" Option: 4.4 gpm (16,6 L/min)	S	S.A.E. Spline, 1.250 inch (31,75 mm)		
08	Standard: 5.4 gpm (20,4 L/min) "H" Option: 5.3 gpm (19,9 L/min)	Operating Pressure			
09	Standard: 6.0 gpm (22,7 L/min) "H" Option: 5.9 gpm (22,3 L/min)	No Code	Standard Pressure		
10	Standard: 6.8 gpm (25,7 L/min) "H" Option: 6.7 gpm (25,3 L/min)	H	High Pressure ^①		
12	Standard: 8.2 gpm (31,0 L/min) "H" Option: 8.1 gpm (30,7 L/min)	① Requires "A" or "B" port option.			

① Output flows based on typical performance at maximum pressure. Refer to performance curves for flows at lower pressures.
② Models PF4303 and PF4304 have three pistons; Models PF4305, PF4308, PF4309 and PF4310 have five pistons; Models PF4306 and PF4312 have six pistons.

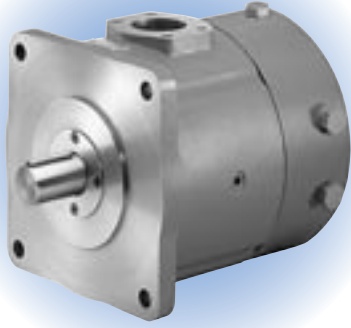

PUMP DESCRIPTION

Fixed displacement checkball pumps, with bi-directional shaft rotation, provide constant direction of output flow regardless of the direction of drive shaft rotation.

Mounting

S.A.E. E 4-bolt pattern with 0.25 inch (6,4 mm) pilot engagement;

Shaft Options

Standard keyed shaft, 1.750 inch (44,45 mm) diameter;

Optional spline shaft, 1.748/1.747 inch diameter standard S.A.E. 13 tooth, 8/16 D.P. 30° involute spline. Contact the sales department for model number.

Outlet Port Options

Higher pressure models (PF6023, PF6033 and PF6046) require an outlet port block kit. Refer to page 28. Standard pressure models (PF6054, PF6070 and PF6080) have outlet ports with a pattern for standard 1 inch S.A.E. 4-bolt flange.

Inlet Conditions

Pumps may require pressurized inlet conditions at higher speeds. Failure to meet minimum inlet requirements will result in slight flow reduction. Refer to the table.

Seal Options

Standard seals are Fluorocarbon (Viton® or Fluorel®) with high-pressure shaft seal. Contact the sales department for other seal options.

Weight (Mass)

PF6023, PF6033 and PF6046:
240 lb (109 kg);

PF6054, PF6070 and PF6080:
330 lb (150 kg).

Specifications

Pump Models	Output Flow at 1500 rpm ^①		Output Flow at 1800 rpm ^①		Rated Pressure		Maximum Intermittent Pressure ^②		Rated Speed rpm	Maximum Speed rpm
	U.S. gpm	L/min	U.S. gpm	L/min	psi	bar	psi	bar		
<i>Outlet Block with Coned and Threaded Port:^③</i>										
PF6023-3167	10.5	40,0	12.7	48,0	15 000	1040	15 000	1040	1800	1800
<i>Outlet Block with S.A.E., Coned and Threaded, or B.S.P. Port:^{③④}</i>										
PF6033-3169	18.3	69,3	22.0	83,2	10 000	700	10 000	700	1800	1800
PF6046-3174	26.0	98,7	31.3	118,4	8000	560	8000	560	1800	1800
<i>Standard S.A.E. 4-Bolt Flange Outlet Port:</i>										
PF6054-2946	29.5	111,6	35.4	134,0	6000	420	6000	420	1800	2400
PF6070-3186	39.6	150,1	47.6	180,1	6000	420	6000	420	1800	2300
PF6080-2989	45.0	170,3	54.0	204,4	5500	380	5500	380	1800	2200

① Output flow based on typical performance at rated pressure with pressurized inlet where required, as shown in the table below.

② Contact the sales department for applications requiring higher intermittent operating pressures.

③ High pressure Coned and Threaded outlet port uses Autoclave Medium Pressure, Butech M/P or equivalent fitting. Refer to "Outlet Port Block Kits" on page 28.

④ B.S.P. outlet port uses British Standard Pipe fitting. Refer to "Outlet Port Block Kits" on page 28.

Minimum Inlet Pressure^①

Pump Models	Operating Speed							
	1200 rpm		1500 rpm		1800 rpm		2400 rpm	
	psi	bar	psi	bar	psi	bar	psi	bar
PF6023	0	0	5	0,4	10	0,7	–	–
PF6033	0	0	10	0,7	15	1,0	–	–
PF6046	0	0	5	0,4	10	0,7	–	–
PF6054	0	0	5	0,4	5	0,4	10	0,7
PF6070	0	0	5	0,4	10	0,7	10 ^②	0,7 ^②
PF6080	5	0,4	5	0,4	10	0,7	15 ^②	1,0 ^②

① Values shown are based on fluid viscosity of 100 SUS (20 cSt). All PF6000 Series pumps have a high-pressure shaft seal.

② Refer to maximum speeds indicated in the "Specifications" table.

PUMP SELECTION

The "Specifications" table lists the most commonly used standard models with keyed shafts. Contact the sales department for model numbers with spline shafts, optional seals and other extraordinary operating requirements.

Maximum Pressure

Checkball pumps are especially suited for applications susceptible to excessive pressure spikes.

The intermittent pressures listed are the maximum pressures a pump can sustain for occasional, short periods of operation without appreciably reducing life expectancy.

Split-Flow® Provides Multiple Outlets

Split-Flow® models efficiently supply flows for multiple function circuits.

PF6000 Series models are available with individual piston outputs grouped together in the barrel or cover. Various piston flow splits are available in this ten-piston pump.

Models PF6033 and PF6046 are also available with isolator valves, to separate one or more pistons from the main outlet. Up to ten independent flows are possible from these ten-piston pumps. When using isolator valves, high-pressure models are limited to a maximum pressure of 6000 psi (420 bar).

Contact the sales department for Split-Flow® options and availability.

PF6000 SERIES

Typical Performance Curves

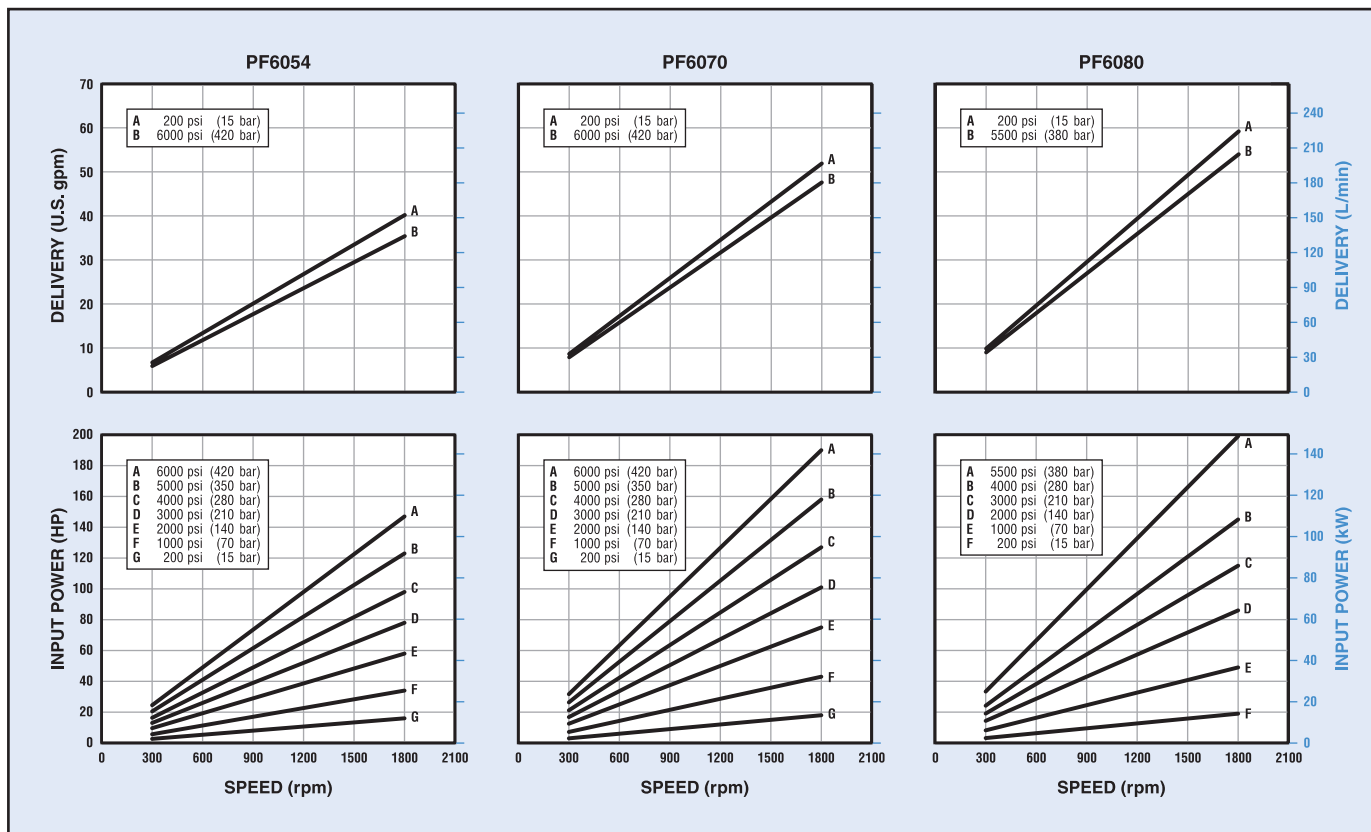
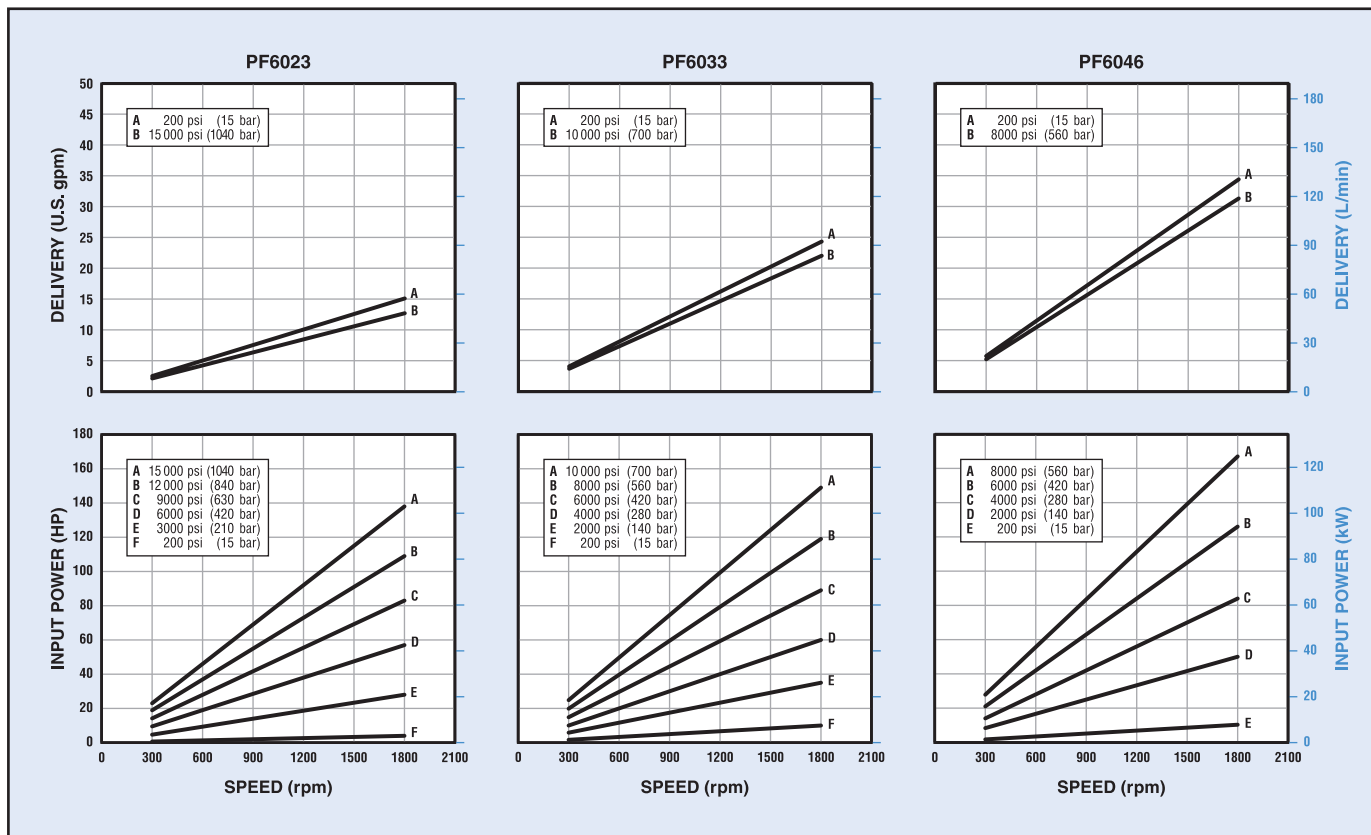

Typical performance curves are based on 100 SUS (20 cSt) mineral oil with pressurized inlet where required. Refer to the "Minimum Inlet Pressure" table on page 26.

INSTALLATION

All dimensions are shown in inches (millimeters in parentheses) and are nominal. Refer to page 26 for optional spline shaft data. Refer to Bulletin PSI.CB for general installation and operating recommendations.

Models PF6023, PF6033 and PF6046

The drawing shows dimensions common to these models. Note, however, that Model PF6023 has eight pistons, rather than ten.

As shown, the outlet port on these high-pressure models is machined in a block, which mounts axially on the pump barrel.

The block is not included with the pump. A kit, which includes mounting bolts and o-rings, must be ordered separately. Refer to the table and to "Outlet Port Configurations" on page 43 to specify the port.

Models PF6054, PF6070 and PF6080

As shown, these models have an auxiliary inlet port in the cover, which provides more fluid to improve the filling of the piston pumping chambers. Use of this port will increase volumetric efficiency.

The drawing shows dimensions common to these three models. Note, however, the different dimensions for the outlet port and the overall length for model PF6080.

Outlet Port Block Kits

Port Type	Kit Number
<i>Model PF6023:</i>	
Coned and Threaded ^①	KP60239131
<i>Models PF6033 and PF6046:</i>	
No. 16 S.A.E. ^②	KP60339132
Coned and Threaded ^①	KP60339133
G 3/4 (B.S.P.) ^③	KP60339134

- ① High pressure outlet port uses Autoclave Medium Pressure, Butech M/P or equivalent fitting.
- ② Not recommended for operation above 8000 psi (560 bar). Contact the fitting manufacturer for the pressure rating of the fitting.
- ③ Outlet port uses British Standard Pipe fitting. Not recommended for operation above 10 000 psi (700 bar).

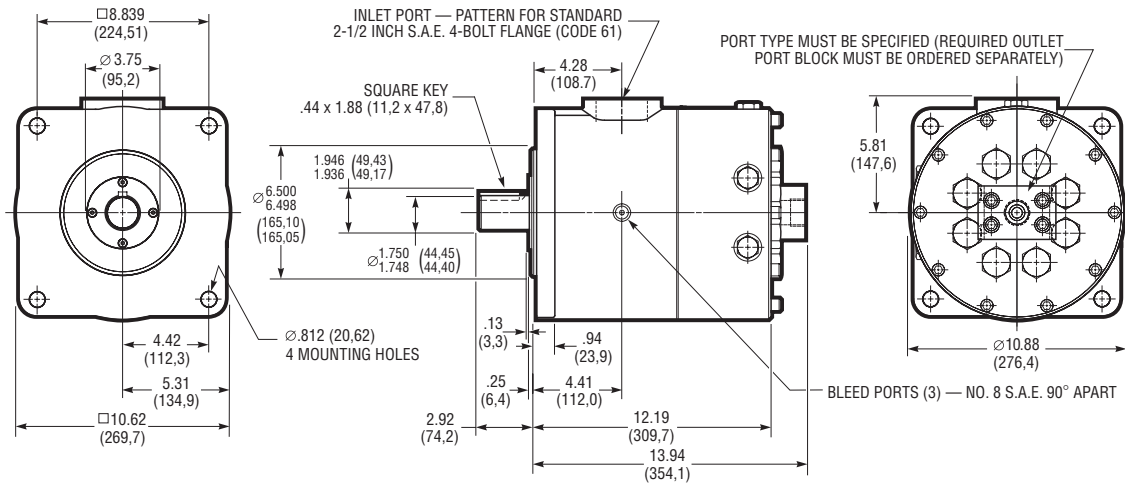

Models PF6023-3167, PF6033-3169 and PF6046-3174

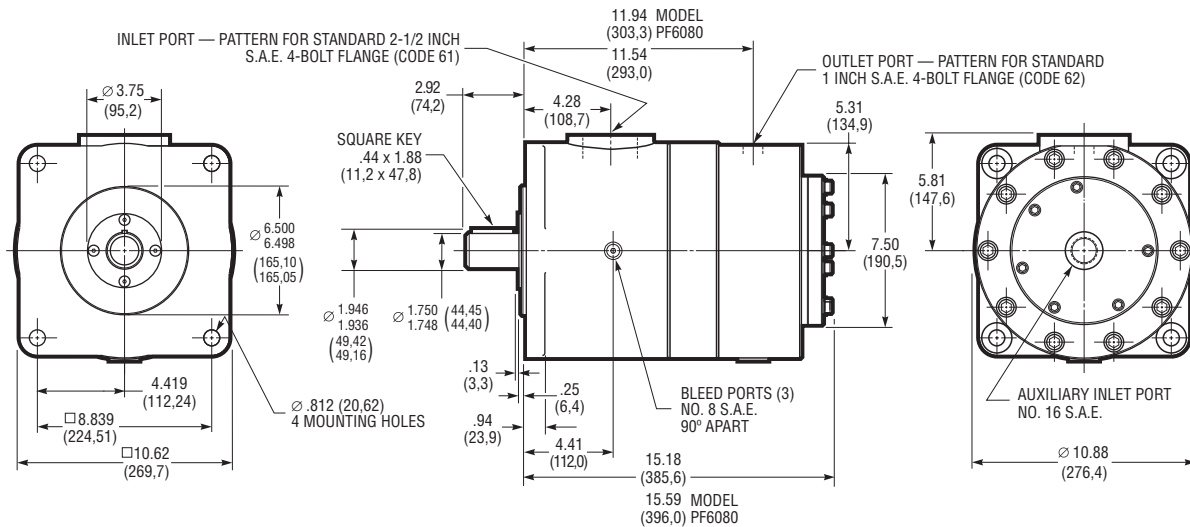

Models PF6054-2946, PF6070-3186 and PF6080-2989

MECHANICAL VARIABLE PUMPS

EFFICIENT VARIABLE DELIVERY

Checkball pump delivery is controlled by variable inlet ports in each piston pumping chamber. In these mechanical variable models, output is adjusted by the linear movement of a spring-biased volume control stem.

Fluid not needed to meet system requirements returns to tank at low pressure, typically 100 psi (7 bar). The result is efficient pump control, providing infinitely variable flow to the system.

Pressure Compensated Models

Compensated pumps vary their output flow to maintain a preset maximum pressure. The integral compensator internally overrides the maximum volume control to smoothly regulate delivery.

Pump Selection

Pump Type and Series	Maximum Flow at 1800 rpm	Rated Pressure	Intermittent Pressure
Mechanical Variable Pumps:			
PV4000 Series	12.2 to 22.4 U.S. gpm (46,2 to 84,8 L/min)	All Models 4000 psi (280 bar)	All Models 6000 psi (420 bar)
Mechanical Variable with Pressure Compensator:			
PV4000 Series	12.0 to 22.4 U.S. gpm (45,4 to 84,8 L/min)	4000 or 8000 psi (280 or 560 bar)	6000 or 8500 psi (420 or 590 bar)
PV6000 Series	31.1 to 61.4 U.S. gpm (117,7 to 232,4 L/min)	All Models 6000 psi (420 bar)	6000 or 8500 psi (420 or 590 bar)

HOW OUTPUT IS CONTROLLED

Pump output is regulated by variable inlet ports located between the inlet and outlet check valves in each piston pumping chamber. The angle of the rotating wobble plate remains constant during operation.

Isolated Fluid is Pressurized

The opening and closing of the variable inlet ports, during each piston stroke, determines the amount of fluid isolated and pressurized in the chamber. Fluid not needed to meet output requirements is diverted to tank at low pressure.

In mechanical variable pumps, the variable inlet ports are opened and closed by poppets, which move in contact with an internal eccentric cam shaft. This spring-loaded cam shaft rides inside a sleeve which rotates with the drive shaft.

Variable Ports Open and Close

As the drive shaft and cam rotate, the poppets move radially on the cam. This causes the poppets to unseat and seat, once during each shaft revolution and piston stroke.

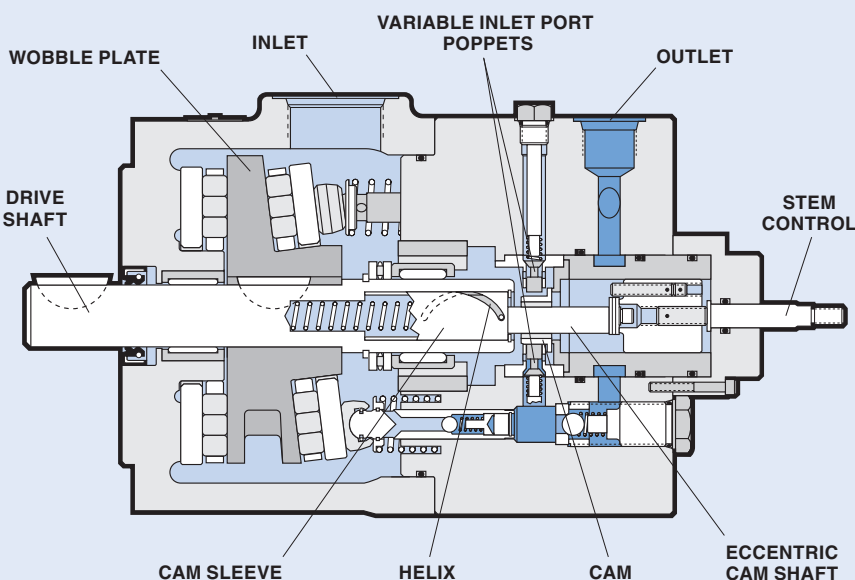

Linear movement of the volume stem control pushes the cam shaft into the sleeve. As the stem moves, a helix in the sleeve causes the cam shaft to turn in the sleeve.

Stem Movement Changes Timing

Turning the cam shaft changes the position of maximum cam eccentricity, changing the timing,

or duration during which the variable inlet ports are open relative to each piston's stroke.

Adjusting the volume stem control affects the timing and the output of all pistons in an identical manner. For example, as the stem is moved in (on standard PV4000 Series pumps), the duration is shortened and pump output increases.

PV4000 SERIES



Specifications

Pump Models	Output Flow at 1500 rpm ^①		Output Flow at 1800 rpm ^①		Rated Pressure		Maximum Intermittent Pressure		Rated Speed rpm	Maximum Speed rpm
	U.S. gpm	L/min	U.S. gpm	L/min	psi	bar	psi	bar		
PV4018-2928	10.1	38,2	12.2	46,2	4000	280	6000	420	2000	2400
PV4026-2929	14.7	55,6	17.6	66,6	4000	280	6000	420	2000	2400
PV4033-2117	18.7	70,8	22.4	84,8	4000	280	6000	420	1800	2100

^① Output flow based on typical performance at rated pressure with pressurized inlet where required, as shown in the table below.

PUMP DESCRIPTION

PV4000 Series checkball pumps supply infinitely variable flow. Output is regulated by mechanically controlled variable inlet ports in each piston pumping chamber.

Mechanical variable pumps are not bi-rotational; rotation must be specified, viewed from the shaft end.

Mounting

S.A.E. D 4-bolt pattern with 0.25 inch (6,4 mm) pilot engagement.

Shaft Options

Standard keyed shaft, 1.250 inch (31,75 mm) diameter;

Optional spline shaft, 1.248/1.247 inch diameter standard S.A.E. 14 tooth, 12/24 D.P. 30° involute spline.

Outlet Port

Standard S.A.E. ports. See "Outlet Port Configurations" on page 43.

Inlet Conditions

Pumps may require pressurized inlet conditions at higher speeds. Failure to meet minimum inlet requirements will result in slight flow reduction. Refer to the table.

Seal Options

Standard seals are Buna-N (Nitrile). Options include Fluorocarbon (Viton® or Fluorel®) or EPR for use with some phosphate ester fluids.

Inlet pressures higher than 10 psig (0,7 bar) require a high-pressure shaft seal.

Weight (Mass)

125 lb (57 kg)

Minimum Inlet Pressures^①

Pump Models	Operating Speed							
	1200 rpm		1500 rpm		2100 rpm		2400 rpm	
	psi	bar	psi	bar	psi	bar	psi	bar
PV4018 and PV4026	0	0	5	0,4	5	0,4	10	0,7
PV4033	0	0	5	0,4	5	0,4	—	—

^① Values shown are based on fluid viscosity of 100 SUS (20 cSt). Inlet pressures higher than 10 psig (0,7 bar) require a high-pressure shaft seal.

PUMP SELECTION

The "Specifications" table includes the most commonly used standard models with keyed shafts.

Models listed are for clockwise rotation and deliver zero flow with the volume stem control in the "out", fully-extended position. Models are also available to deliver full flow with the stem extended.

Contact the sales department for models with spline shafts, optional seals, counter-clockwise rotation, different control options and other extraordinary operating requirements.

Maximum Pressure

Checkball pumps are especially suited for applications susceptible to excessive pressure spikes.

The intermittent pressures listed are the maximum pressures a pump can sustain for occasional, short periods of operation without appreciably reducing life expectancy.

Fluid Guidelines

See page 42 for "Fluid Recommendations".

Some pump models may require reduced operating pressures when using low-lubricity fluids.

Because of the wide range of fluid characteristics, contact the sales department for a review of any application using non-petroleum based fluids.

Split-Flow® Provides Multiple Outlets

PV4000 models with split-flow covers efficiently supply flows for multiple function circuits. Piston outputs are grouped together in the cover, with various piston flow splits available in this ten-piston pump.

These pumps are also available with isolator valves, to separate one or more pistons from the main outlet. Up to ten independent flows are possible from these ten-piston pumps.

Contact the sales department for Split-Flow® options and availability.

PV4000 SERIES

Typical Performance Curves

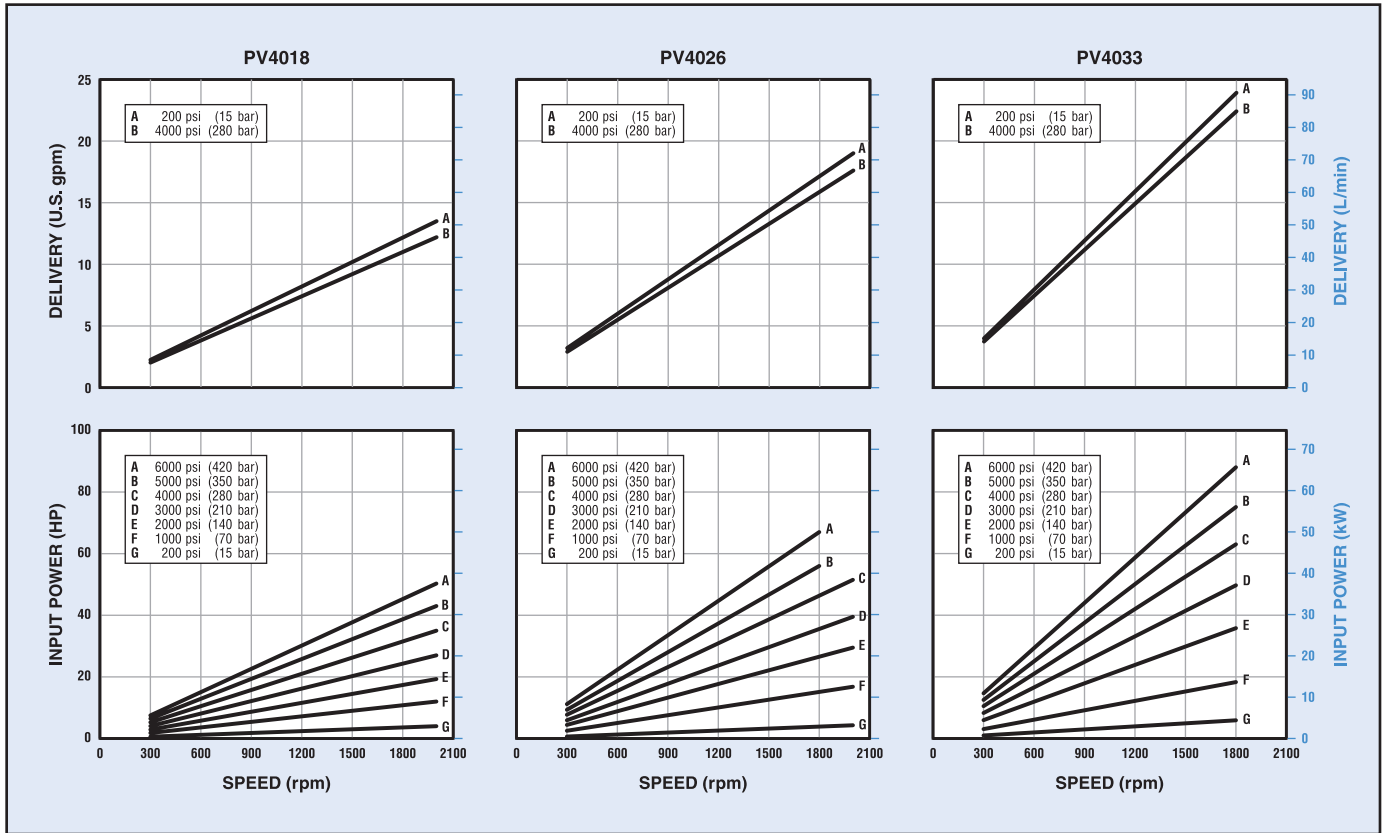

Typical performance curves are based on 100 SUS (20 cSt) mineral oil with pressurized inlet where required. Refer to the "Minimum Inlet Pressure" table on page 30.

INSTALLATION

All dimensions are shown in inches (millimeters in parentheses) and are nominal. See page 30 for optional spline shaft data.

Refer to Bulletin PSI.CB for general installation and operating recommendations.

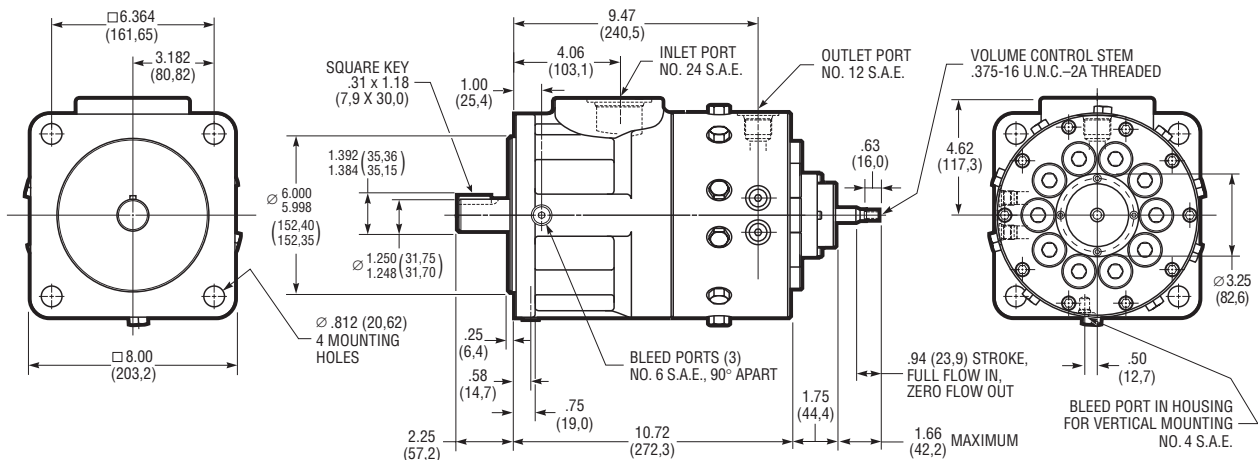

PV4000 PRESSURE COMPENSATED



PUMP DESCRIPTION

These high-pressure checkball pumps adjust their output flow to maintain a preset maximum pressure.

The integral pressure compensator overrides a maximum volume control to smoothly and quietly regulate delivery. Fast response to load conditions assures full power in the system up to a pressure very close to the compensator setting.

These mechanically controlled pumps are not bi-rotational; rotation must be specified, viewed from the shaft end.

Electrohydraulic Remote Control

Electrohydraulic flow control can be achieved using a Dynex Remote Proportional Actuator (RPA). The bracket-mounted actuator strokes the pump volume control stem. See page 34.

For complete RPA specifications, refer to Bulletin EES.RPA.

Mounting

S.A.E. D 4-bolt pattern with 0.25 inch (6,4 mm) pilot engagement.

Shaft

Standard keyed shaft, 1.250 inch (31,75 mm) diameter;

Outlet Port Options

Standard S.A.E. ports. See "Outlet Port Configurations" on page 43.

Inlet Conditions

Pumps may require pressurized inlet conditions at higher speeds. Failure to meet minimum inlet requirements will result in slight flow reduction. Refer to the table.

Specifications

Pump Models	Output Flow at 1500 rpm ^①		Output Flow at 1800 rpm ^①		Rated Pressure		Maximum Intermittent Pressure		Rated Speed rpm	Maximum Speed rpm
	U.S. gpm	L/min	U.S. gpm	L/min	psi	bar	psi	bar		
<i>Pressure Compensated with Volume Stem Control:</i>										
PV4020-3046	9.8	37,1	12.0	45,4	8000 ^②	560	8500 ^②	590	1800	1800
PV4026-3126	14.7	55,6	17.6	66,6	4000	280	6000	420	1800	1800
PV4033-3127	18.7	70,8	22.4	84,8	4000	280	6000	420	1800	1800
<i>Pressure Compensated with Electrohydraulic Control:</i>										
PV4020-3187	9.8	37,1	12.0	45,4	8000 ^②	560	8500 ^②	590	1800	1800
PV4026-3188	14.7	55,6	17.6	66,6	4000	280	6000	420	1800	1800
PV4033-3189	18.7	70,8	22.4	84,8	4000	280	6000	420	1800	1800

^① Output flow based on typical performance at rated pressure with pressurized inlet where required, as shown in the table below.

^② The pressure rating may be limited by the fitting used in the No. 12 S.A.E. outlet port. Contact the fitting manufacturer for the pressure rating of the fitting.

Minimum Inlet Pressures^①

Pump Models	Operating Speed					
	1200 rpm		1500 rpm		1800 rpm	
	psi	bar	psi	bar	psi	bar
All PV4000 Pressure Compensated Models	0	0	5	0,4	5	0,4

^① Values shown are based on fluid viscosity of 100 SUS (20 cSt). Inlet pressures higher than 10 psig (0,7 bar) require a high-pressure shaft seal.

Seal Options

Standard seals are Buna-N (Nitrile). Options include Fluorocarbon (Viton® or Fluorel®) or EPR for use with some phosphate ester fluids.

Weight (Mass)

Manual Control Models:
140 lb (64 kg)

Electrohydraulic Control Models:
156 lb (71 kg)

PUMP SELECTION

The "Specifications" table includes the most commonly used standard models with keyed shafts.

Models listed are for clockwise rotation. These compensated pumps deliver full flow with the volume stem control in the "out", fully-extended position.

Contact the sales department for models with optional seals, counter-clockwise rotation, different control options and other extraordinary operating requirements.

Maximum Pressure

Checkball pumps are especially suited for applications susceptible to excessive pressure spikes.

The intermittent pressures listed are the maximum pressures a pump can sustain for occasional, short periods of operation without appreciably reducing life expectancy.

Fluid Guidelines

See page 42 for "Fluid Recommendations".

Some pump models may require reduced operating pressures when using low-lubricity fluids.

Because of the wide range of fluid characteristics, contact the sales department for a review of any application using non-petroleum based fluids.

PV4000 PRESSURE COMPENSATED

Typical Performance Curves

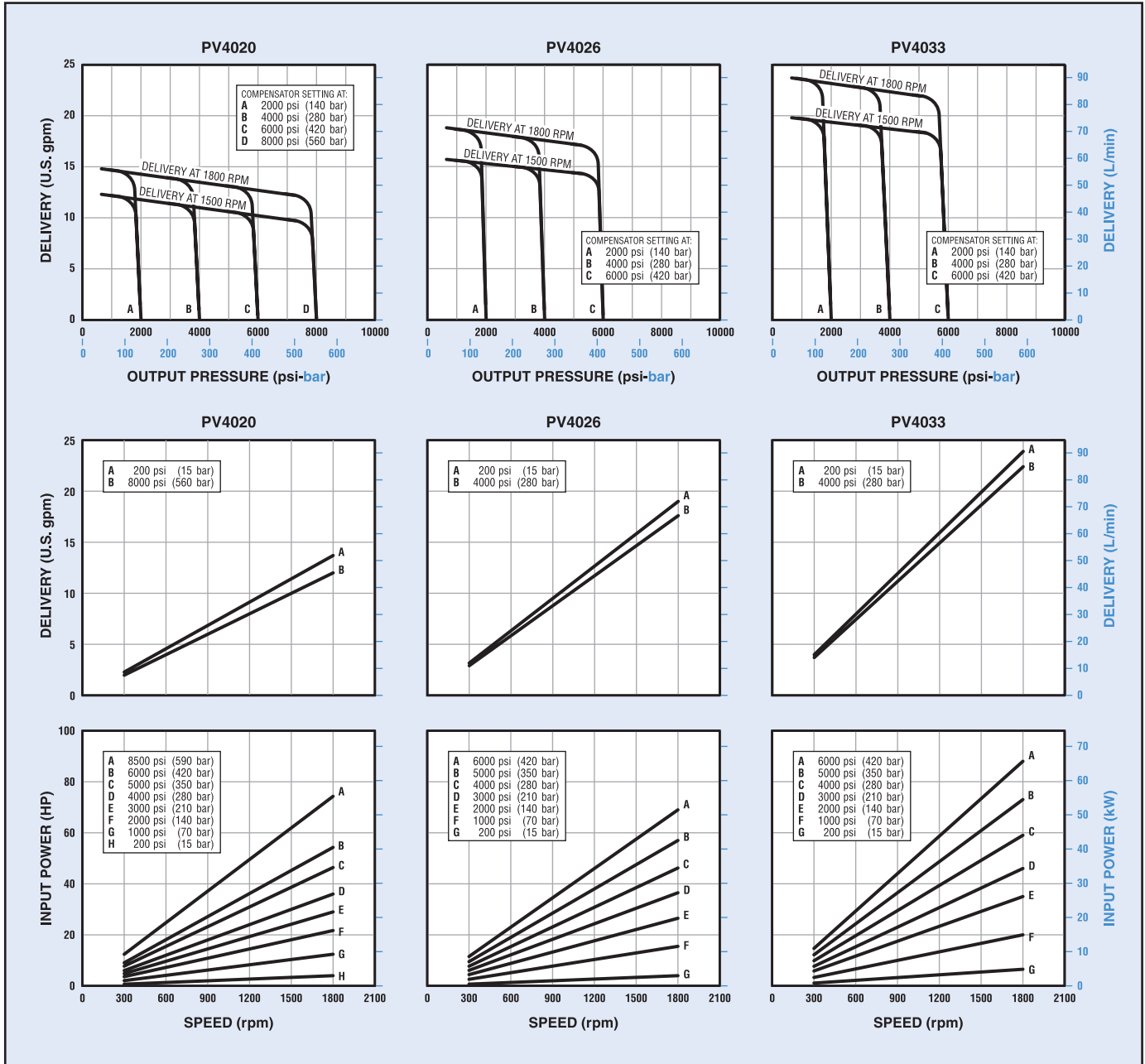

Typical performance curves are based on 100 SUS (20 cSt) mineral oil with pressurized inlet where required. Refer to "Minimum Inlet Pressure" table on page 32.

PV4000 PRESSURE COMPENSATED

INSTALLATION

All dimensions are shown in inches (millimeters in parentheses) and are nominal.

Refer to Bulletin PSI.CB for general installation and operating recommendations.

Volume and Pressure Control

Compensated models deliver full flow with the volume control stem extended out of the pump.

Pressure is set by turning the adjustment clockwise for increased pressure. One-quarter turn equals 1000 psi (70 bar). The adjustment range is 1000 psi (70 bar) to the maximum pressure rating. Maximum torque required to adjust the compensator is 20 lb·in (2,3 N·m).

Pump Inlet/Drain Port

Note the location of the dual purpose inlet/drain port. Acting as an inlet, this port increases volumetric efficiency by improving the filling of the piston chamber.

Acting as a drain, the port diverts unused fluid at low pressure from the chamber, providing improved circulation which dissipates heat.

Electrohydraulic Pump Control

PV4000 Series pumps use a bracket-mounted Dynex Remote Proportional Actuator (RPA) to stroke the pump volume control stem.

Electrohydraulic capability can be added to a standard pump using an Electrohydraulic Control Kit. Refer to the table.

The RPA requires a separate pilot supply: Minimum, 200 psi (15 bar); Maximum, 3000 psi (210 bar). For complete RPA specifications, refer to Bulletin EES.RPA.

Assembly of RPA and Bracket

For ease of shipping, electrohydraulic models are shipped as two sub-assemblies. The RPA/bracket sub-assembly must be mounted to the rear of the pump using the tie rods and nuts provided with the pump. Recommended torque is 40 lb·ft (54 N·m).

Electrohydraulic Control Kits

Pump	Kit Number ^①
<i>PV4000 Series Pumps:</i>	
Pressure Compensated	KP4020-9047
Non-compensated	KP4026-9047

^① Kit includes a bracket and hardware. The Dynex Remote Proportional Actuator must be ordered separately.

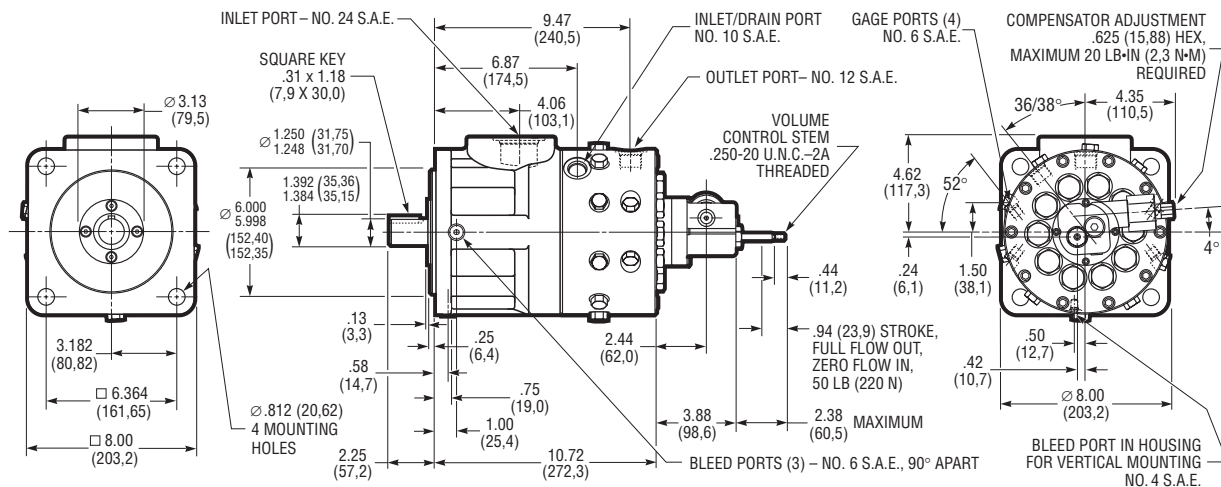

Manual Volume Control Pressure Compensated Models

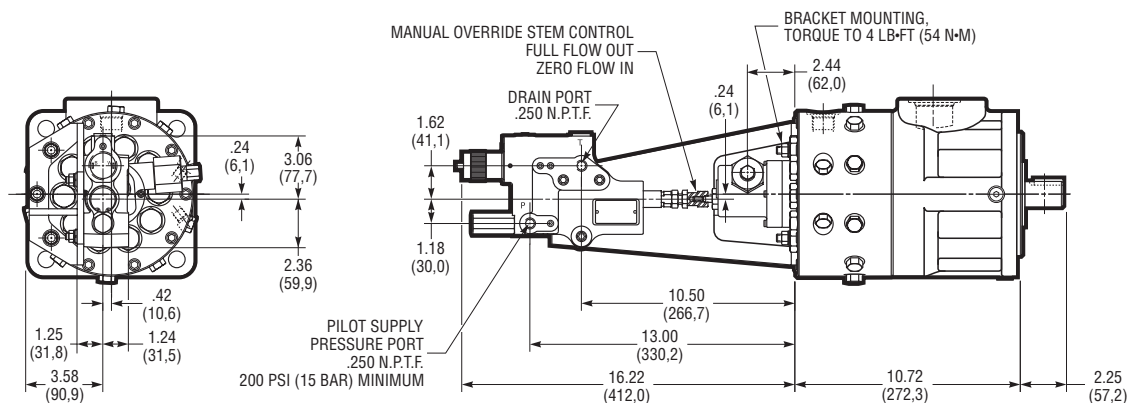

Electrohydraulic Volume Control Pressure Compensated Models

PV6000 PRESSURE COMPENSATED

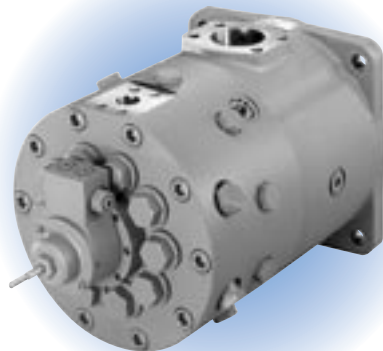

PUMP DESCRIPTION

These high-pressure checkball pumps adjust their output flow to maintain a preset maximum pressure.

The integral pressure compensator overrides a maximum volume control to smoothly and quietly regulate delivery. Fast response to load conditions assures full power in the system up to a pressure very close to the compensator setting.

These mechanically controlled pumps are not bi-rotational; rotation must be specified, viewed from the shaft end.

Electrohydraulic Remote Control

Electrohydraulic flow control can be achieved using a Dynex Remote Proportional Actuator (RPA). The bracket-mounted actuator strokes the pump volume control stem.

Electrohydraulic control is not available for PV6000 Series as an integral unit. Refer to page 37 for information on the Electrohydraulic kit.

For complete RPA specifications, refer to Bulletin EES.RPA.

Mounting

S.A.E. E 4-bolt pattern with 0.25 inch (6,4 mm) pilot engagement.

Standard Spline Shaft

1.748/1.747 inch diameter standard 13 tooth, 8/16 D.P. 30° involute spline.

Specifications

Pump Models	Output Flow at 1500 rpm ^①		Output Flow at 1800 rpm ^①		Rated Pressure		Maximum Intermittent Pressure		Rated Speed rpm	Maximum Speed rpm
	U.S. gpm	L/min	U.S. gpm	L/min	psi	bar	psi	bar		
<i>Pressure Compensated with Volume Stem Control:</i>										
PV6046-3177	25.9	98,1	31.1	117,7	6000	420	8500	590	1800	1800
PV6054-3183	30.5	115,5	36.7	138,9	6000	420	8500	590	1800	1800
PV6070-3502	40.0	151,4	48.0	181,7	6000	420	8500	590	1800	1800
PV6089-3498	51.2	193,8	61.4	232,4	6000	420	6000 ^②	420 ^②	1800	1800

^① Output flow based on typical performance at rated pressure with pressurized inlet where required, as shown in the table below.

^② For applications requiring intermittent operation above 6000 psi (420 bar), contact the sales department.

Minimum Inlet Pressures^①

Pump Models	Operating Speed					
	1200 rpm		1500 rpm		1800 rpm	
	psi	bar	psi	bar	psi	bar
PV6046 and PV6054	0	0	3	0,2	5	0,4
PV6070	3	0,2	8	0,6	10	0,7
PV6089	5	0,4	10	0,7	15	1,0

^① Values shown are based on fluid viscosity of 100 SUS (20 cSt). All PV6000 Series pumps have a high-pressure shaft seal.

Outlet Port

As shown, the standard S.A.E. No. 16 outlet port on these pumps is machined in a block integrally mounted to the pump barrel. See "Outlet Port Configurations" on page 43.

Inlet Conditions

Pumps may require pressurized inlet conditions at higher speeds. Failure to meet minimum inlet requirements will result in slight flow reduction. Refer to the table.

Seal Options

Standard seals are Fluorocarbon (Viton® or Fluorel®). All PV6000 Series pumps have a high-pressure shaft seal. Options include EPR seals for use with some phosphate ester fluids.

Weight (Mass)

Models PV6046, PV6054 and PV6070:
345 lb (156 kg)

Model PV6089:
360 lb (163 kg)

PUMP SELECTION

The "Specifications" table includes the most commonly used standard models with spline shafts.

Models listed are for clockwise rotation. These compensated pumps deliver full flow with the volume stem control in the "out", fully-extended position.

Contact the sales department for models with optional seals, counter-clockwise rotation, handwheel control option and other extraordinary operating requirements.

Fluid Guidelines

See page 42 for "Fluid Recommendations". Some pump models may require reduced operating pressures when using low-lubricity fluids.

Because of the wide range of fluid characteristics, contact the sales department for a review of any application using non-petroleum based fluids.

PV6000 PRESSURE COMPENSATED

Typical Performance Curves

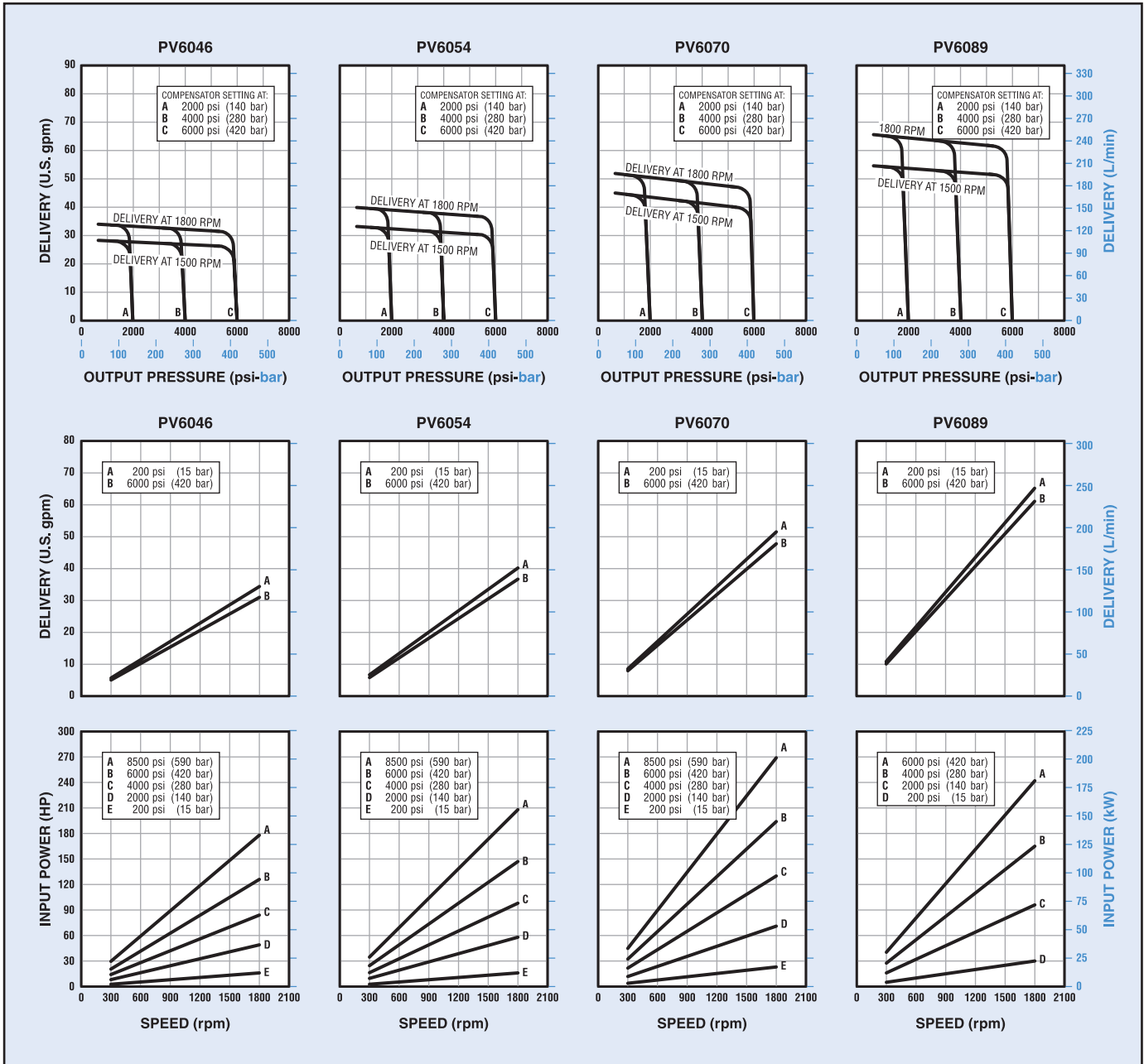

Typical performance curves are based on 100 SUS (20 cSt) mineral oil with pressurized inlet where required. Refer to "Minimum Inlet Pressure" table on page 35.

PV6000 PRESSURE COMPENSATED

INSTALLATION

All dimensions are shown in inches (millimeters in parentheses) and are nominal.

Refer to Bulletin PSI.CB for general installation and operating recommendations.

Volume and Pressure Control

Compensated models deliver full flow with the volume control stem extended out of the pump.

Pressure is increased by turning the adjustment clockwise. One-quarter turn equals 1000 psi (70 bar), with a range from

1000 psi (70 bar) to the maximum pressure rating. Maximum torque required to adjust the compensator is 30 lb·in (3,4 N·m).

Pump Inlet/Drain Port

Note the location of the dual purpose inlet/drain port. Acting as an inlet, this port increases volumetric efficiency by improving the filling of the piston chamber.

Acting as a drain, the port diverts unused fluid at low pressure from the chamber, providing improved circulation which dissipates heat.

Electrohydraulic Remote Control

Electrohydraulic flow control can be achieved using a Dynex Remote Proportional Actuator (RPA) to stroke the volume control stem.

Electrohydraulic capability can be added using Kit KP6046-9047, which includes a bracket and hardware. The RPA must be ordered separately.

The RPA requires a separate pilot supply: Minimum, 200 psi (15 bar); Maximum, 3000 psi (210 bar). For complete RPA specifications, refer to Bulletin EES.RPA.

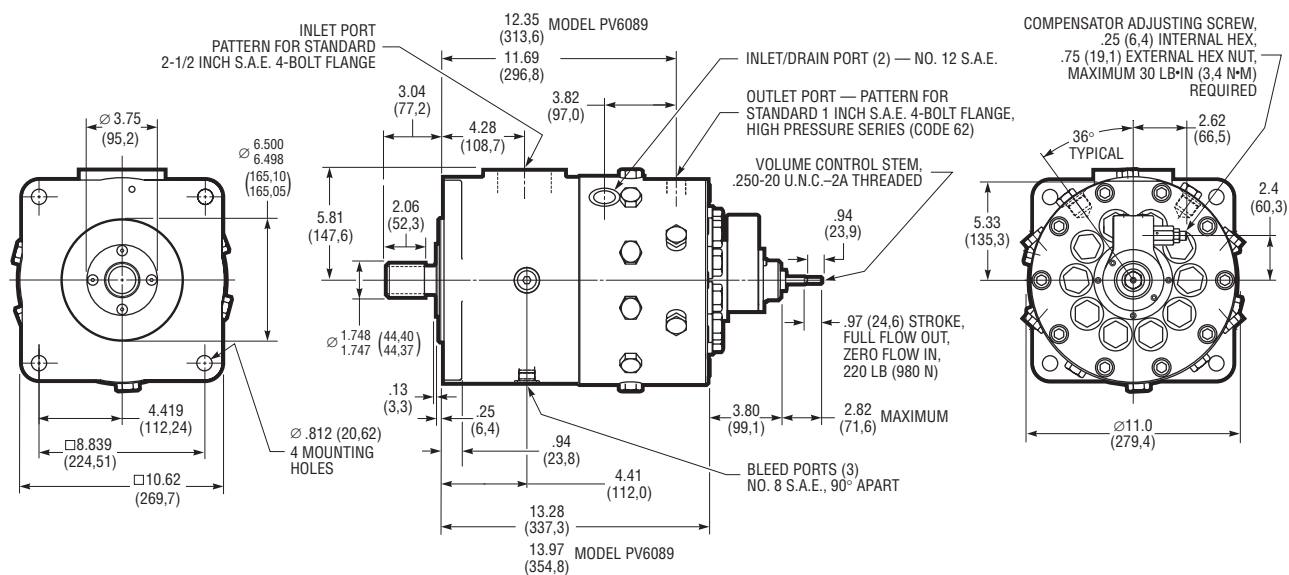

HYDRAULIC VARIABLE PUMPS

EFFICIENT VARIABLE DELIVERY

Checkball pump delivery is controlled by variable inlet ports in each piston pumping chamber. In these hydraulic variable models, output is regulated by a variable low-pressure control signal, supplied to a control port in the pump cover.

Fluid not needed to meet system requirements returns to tank at low pressure, typically 100 psi (7 bar). The result is efficient pump control, providing infinitely variable flow to the system.

Pump Volume Controls

Pump volume controls for PV6000 Series pumps, including a remote pressure compensator, improve the control and design flexibility of hydraulic circuits.

Typical Motor Circuit

A typical open loop circuit uses a combination volume/direction control valve to regulate the control signal. As the valve lever is moved to either side of center, the output pressure

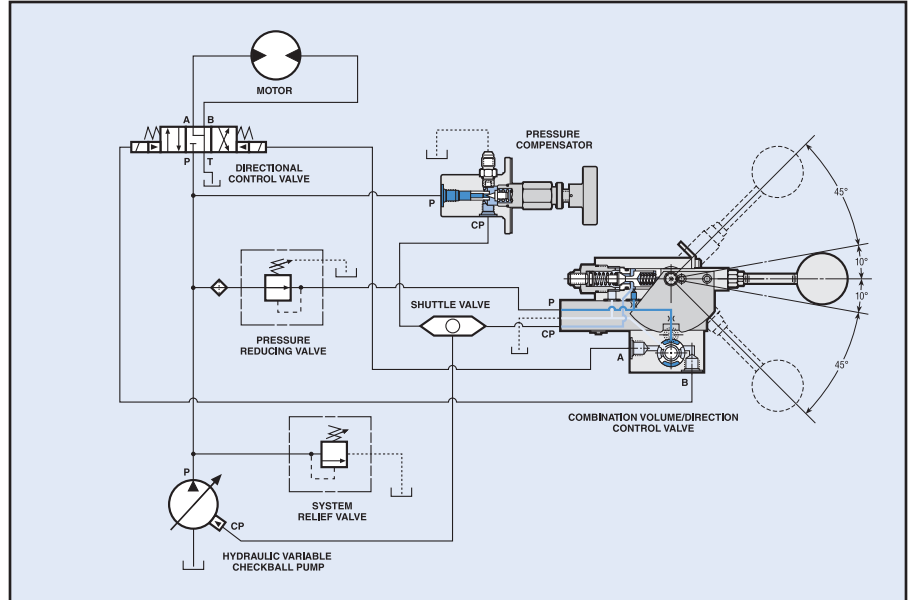

from the "CP" port decreases, which is sensed at the pump control port "CP". This results in an increase in pump output. Simultaneously, flow from the "A" or "B" port travels to the

directional valve controlling the motor. This pilot supply hydraulically controls actuator direction, providing an over-center function at the motor.

HOW OUTPUT IS CONTROLLED

Pump output is regulated by variable inlet port checkballs in parallel with the outlet check valves of each piston pumping chamber.

Pressure Signal Controls Output

These variable inlet checkballs are opened and closed by a variable control signal, 0 to 180 psi (0 to 12 bar), externally supplied to the control port in the pump cover.

When full flow is not required, the control signal unseats the variable inlet checkball at the start of the piston stroke. As the piston accelerates, the resulting flow forces across the checkball increase until the signal is overcome and the checkball seats.

Remaining Fluid is Pressurized

The fluid remaining in the pumping chamber then rises to system pressure. The outlet checkball then unseats. Piston outputs are

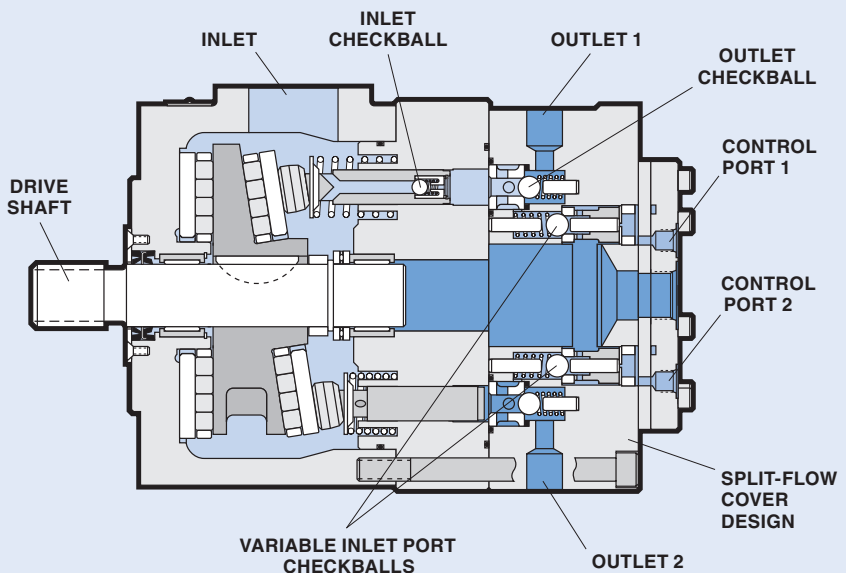

combined in the barrel and discharged from the pump outlet.

Increasing the control signal, for example, increases the duration during which the variable inlet port checkballs are unseated and decreases pump output.

Multiple Outlet Pumps

Split-Flow® pumps supply two independent flows to the circuit. The ten-piston pump provides five-piston output from each outlet port, regulated by the variable pressure signal supplied to its corresponding control port.

PV6000 HYDRAULIC VARIABLE



Specifications

Pump Models	Output Flow at 1500 rpm ^①		Output Flow at 1800 rpm ^①		Rated Pressure		Maximum Intermittent Pressure ^②		Rated Speed rpm	Maximum Speed rpm
	U.S. gpm	L/min	U.S. gpm	L/min	psi	bar	psi	bar		
<i>Standard S.A.E. 4-Bolt Flange Outlet Port:</i>										
PV6054-3065	29.5	111,6	35.4	134,0	6000	420	6000	420	1800	2400
PV6070-3066	39.6	150,1	47.6	180,1	6000	420	6000	420	1800	2300
PV6080-2923	45.0	170,3	54.0	204,4	5500	380	5500	380	1800	2200

① Output flow based on typical performance at rated pressure with pressurized inlet where required, as shown in the table below.

② Contact the sales department for applications requiring higher intermittent operating pressures.

PUMP DESCRIPTION

PV6000 Series checkball pumps supply infinitely variable flow. Output is regulated by an external low-pressure control signal supplied to a control port in the cover.

These pumps, with bi-directional shaft rotation, provide constant direction of output flow regardless of the direction of drive shaft rotation.

Mounting

S.A.E. E 4-bolt pattern with 0.25 inch (6,4 mm) pilot engagement.

Standard Spline Shaft

1.748/1.747 inch diameter standard S.A.E. 13 tooth, 8/16 D.P. 30° involute spline.

Outlet Port Options

Pattern for standard 1 inch S.A.E. 4-bolt flange. Refer to "Outlet Port Configurations" on page 43.

Inlet Conditions

Pumps may require pressurized inlet conditions at higher speeds. Failure to meet minimum inlet requirements will result in slight flow reduction. Refer to the table.

Seal Options

Standard seals are Buna-N (Nitrile). Options include Fluorocarbon (Viton® or Fluorel®) or EPR for use with some phosphate ester fluids.

Weight (Mass)

330 lb (150 kg)

Minimum Inlet Pressure^①

Pump Models	Operating Speed							
	1200 rpm		1500 rpm		1800 rpm		2400 rpm	
	psi	bar	psi	bar	psi	bar	psi	bar
PV6054	0	0	5	0,4	5	0,4	10	0,7
PV6070	0	0	5	0,4	10	0,7	10 ^②	0,7 ^②
PV6080	5	0,4	5	0,4	10	0,7	15 ^②	1,0 ^②

① Values shown are based on fluid viscosity of 100 SUS (20 cSt). All PV6000 Series pumps have a high-pressure shaft seal.

② Refer to maximum speeds indicated in the "Specifications" table.

PUMP SELECTION

The "Specifications" table lists the most commonly used standard models with standard spline shafts and high-pressure shaft seals.

Contact the sales department for model numbers with optional seals and other extraordinary operating requirements.

Regulating Pump Output

Pump volume controls, including remote pressure compensators, improve the flexibility of hydraulic circuits. Refer to "Typical Open Loop Circuit" on page 38 and contact the sales department for ordering information.

Fluid Guidelines

See page 42 for "Fluid Recommendations".

Some pump models may require reduced operating pressures when using low-lubricity fluids.

Because of the wide range of fluid characteristics, contact the sales department for a review of any application using non-petroleum based fluids.

Split-Flow® Provides Multiple Outlets

PV6000 Series models with split-flow covers efficiently supply flows for multiple function circuits. Piston outputs are grouped together in the cover, with this ten-piston pump providing five-piston output from each of two independent ports. See "Split-Flow® Output" on page 41.

Tandem Pump Models

PV6000 Series pumps with thru-shaft configuration simplify circuits by eliminating separate dedicated pumps and drives, and reducing piping and installation time.

A tandem mounted pump is ideal for supplying auxiliary functions. Separate flows to multiple functions in a circuit can be supplied by one unit, driven by a common drive shaft.

PV6000 HYDRAULIC VARIABLE

Typical Performance Curves

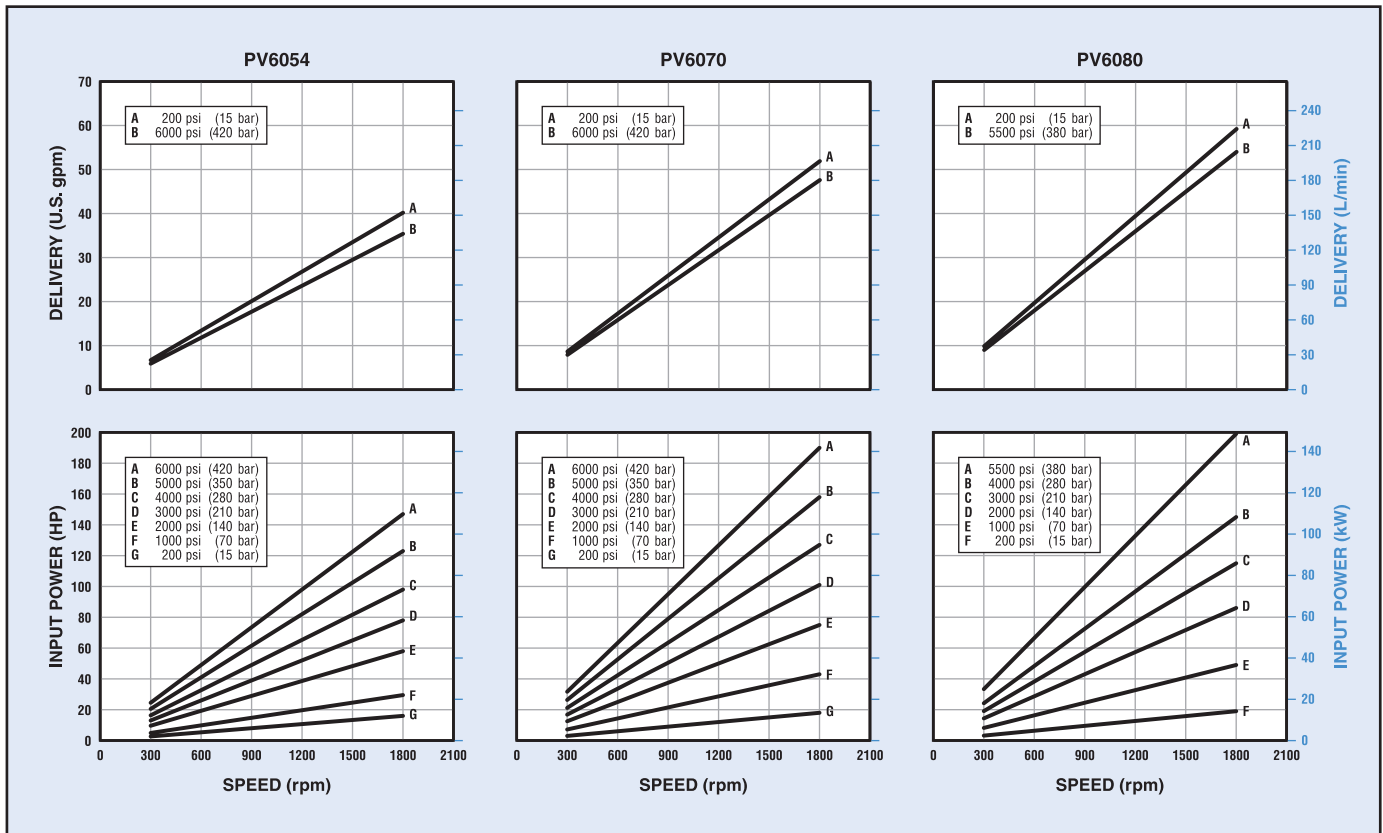

Typical performance curves are based on 100 SUS (20 cSt) mineral oil with pressurized inlet where required. Refer to the "Minimum Inlet Pressure" table on page 39.

INSTALLATION

All dimensions are shown in inches (millimeters in parentheses) and are nominal. Refer to Bulletin PSI.CB for general installation and operating recommendations.

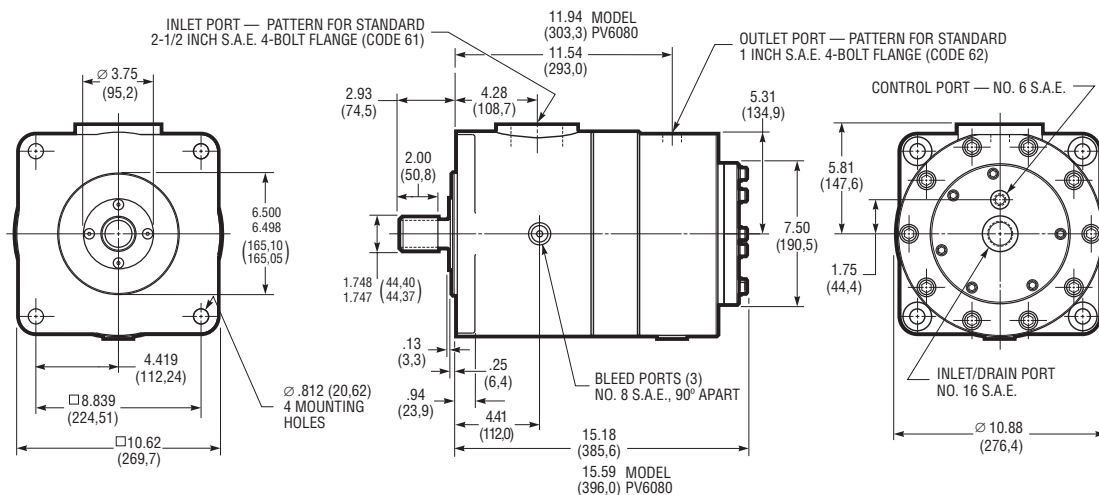

PV6000 Series Standard Full-Flow Configuration

PV6000 HYDRAULIC VARIABLE

Pump Inlet/Drain Port

Note the location of the dual purpose inlet/drain port. Acting as an inlet, this port increases volumetric efficiency by improving the filling of the piston chamber.

Acting as a drain, the port diverts unused fluid at low pressure from the chamber, providing improved circulation which dissipates heat.

Split-Flow® Output

As shown in the circuit, the Split-Flow® PV6000 Series pump can supply two variable flows, or one fixed and one variable flow.

Each output (P1 and P2) is independently controlled by its own external control pressure signal (CP1 and CP2). See "How Output is Controlled" on page 38.

Tandem Pump Mounting

Any accessory pump with a standard S.A.E. B 2-bolt or 4-bolt pattern can be tandem mounted on the PV6000 Series Thru-Shaft pump. The internal coupling is a standard S.A.E. B spline.

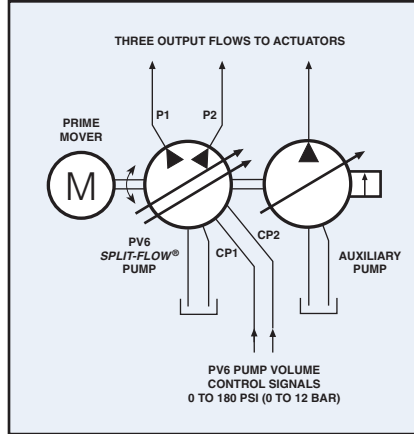

This 10-piston Split-Flow® pump provides two 5-piston outputs, plus a third flow delivered from a tandem mounted auxiliary pump.

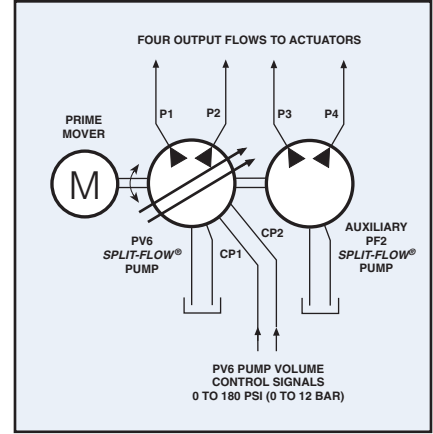

With a two-outlet Split-Flow® PF2000 Series pump as an accessory pump, one unit provides four separate flows driven by a single drive-shaft.

The tandem pump can determine the rotation of both pumps, because shaft rotation of the PV6000 Series is bi-directional, providing constant direction of output flow regardless of drive shaft rotation.

Refer to the installation drawing and the circuit drawings above.

The installation drawing shows a Split-Flow® pump with two independent variable delivery outlet ports (5 pistons output + 5 pistons output).

For complete model numbers and a review of the application, contact the sales department.

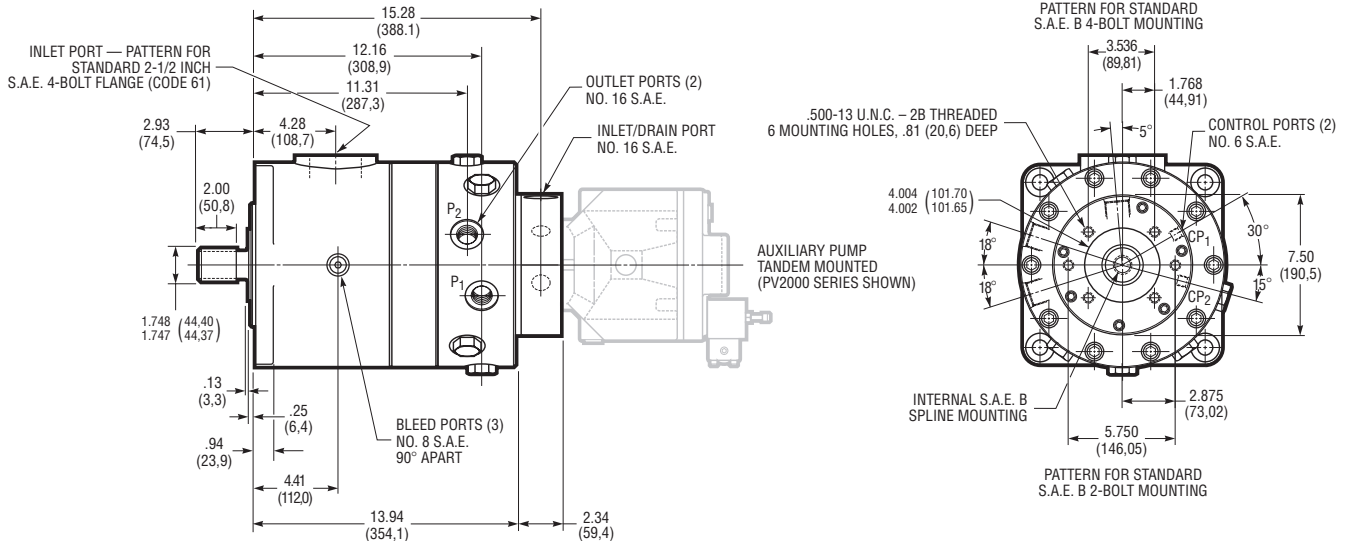

PV6000 Series Split-Flow® Thru-Shaft Configuration

FLUID RECOMMENDATIONS

Mineral Oil

A high-grade premium petroleum-based fluid should be used to assure long component and system life. The fluid should have a combination of anti-wear, demulsibility, rust protection, oxidation-resistant and foam-resistant properties.

Special Fluids

Various pump models are available for use with water-based fluids, diesel calibration fluids, phosphate ester fluids, machining coolant, brake fluid, various military fluids and other special fluids.

PF4300 Series pumps are compatible with a variety of water-based fluids. Refer to page 23 for specifications for these models, which are specifically rated for use with low-lubricity fluids.

Some pump models may require reduced operating pressures when using low-lubricity fluids.

Because of the wide range of fluid characteristics, contact the sales department for a review of any application using non-petroleum based fluids.

Viscosity Specifications

Using fluid with the correct viscosity range is critical to achieving long component life.

Fluid conditions outside the "Optimum" range shown in the table may result in reduced pump output, requiring pressurized inlet conditions. For more information, contact the sales department.

Hydraulic Fluid Viscosity^①

Pump Models	Operating				Start-up ^②		Optimum		
	Minimum		Maximum		SUS	cSt	SUS	cSt	
	SUS	cSt	SUS	cSt					
<i>Fixed Displacement Pumps:</i>									
PF500-10	52	8	1911	413	3706	800	98 to 324	20 to 70	
PF1000-10	59	10	1911	413	3706	800	98 to 324	20 to 70	
PF2000	59	10	1911	413	1911	413	98 to 324	20 to 70	
PF2000 ^②	34	2,3	1911	413	1911	413	98 to 324	20 to 70	
PF3000-10	59	10	1911	413	3706	800	98 to 342	20 to 70	
PF4000-30	34	2,3	1911	413	1911	413	98 to 324	20 to 70	
PF4200-10	34	2,3	1911	413	1911	413	98 to 324	20 to 70	
PF4300-11	31	1,5	927	200	927	200	–	–	
PF6000	34	2,3	1911	413	1911	413	98 to 324	20 to 70	
<i>Mechanical Variable Delivery Pumps:</i>									
PV4000	34	2,3	1911	413	1911	413	98 to 324	20 to 70	
PV6000	34	2,3	1911	413	1911	413	98 to 324	20 to 70	
<i>Hydraulic Variable Delivery Pumps:</i>									
PV6000	34	2,3	1911	413	1911	413	98 to 324	20 to 70	

① Fluid conditions outside the "Optimum" range may result in reduced output, requiring pressurized inlet conditions. Contact the sales department.

② Models with special mounting.

MINIMUM FILTRATION LEVELS

Pump inlet: 150 μ nominal;

Pressure or return line: 25 μ nominal.

While finer filtration levels than these are desirable and will result in longer component life, restricting flow to the pump inlet should be avoided. Minimum recommended inlet conditions must be maintained.

If a system component fails resulting in fluid contamination, it is important to drain and clean the reservoir, all lines, filter screens and all components. Refill with new fluid.

INSTALLATION AND OPERATION

Refer to separate Bulletin PSI.CB for general installation and operating recommendations.

That brochure includes information on mounting, shaft loading, sizing inlet pipe and hose, air bleed procedures and initial start-up. Guidelines for maintenance, repair and trouble-shooting are also included.

PORT DESCRIPTIONS

Dynex pumps are available with outlet ports suitable for use at various pressure ranges. Refer to the appropriate "Specification Table" or "Typical Model Code" to specify the required port.

Contact the fitting manufacturer to ensure the selected fittings are rated for the maximum pump operating pressure.

S.A.E. Straight Thread Ports

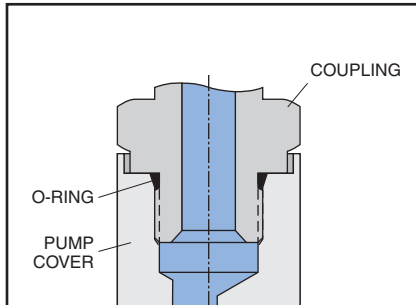

Typical S.A.E. Straight Thread port connection

The Straight Thread connection (S.A.E. J1926/1) is sometimes referred to as an S.A.E. O-ring Boss, or ORB. The port consists of a machined spotface surface, a tapered seal cavity and a straight thread port.

The fitting forms a seal by compressing the o-ring in the seal cavity with the underside of the flanged wrench flat. Some adjustable fittings, such as elbows and tees, use a locknut with a captive backup washer for compression.

S.A.E. Straight Thread ports are not recommended for operation above 8000 psi (560 bar). Also, the maximum pressure of pumps with No. 12 S.A.E. outlet ports may be limited by the pressure rating of the available fitting. Contact the fitting manufacturer for ratings.

Coned and Threaded Ports

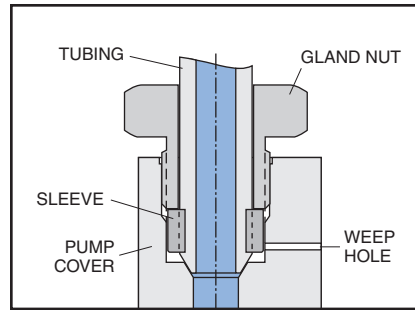

Typical Coned and Threaded port connection

High-pressure pumps are available with coned and threaded outlet ports, which use Autoclave Medium Pressure, Butech M/P, or equivalent fittings.

These fittings provide a metal-to-metal seal with an interference fit, not requiring an o-ring. The gland nut holds the sleeve and tubing against the cone surface.

A weep hole, visible on the outside of the pump cover, acts as an indicator of any abnormal leakage caused by system conditions (i.e., excessive pressure). It allows any fluid which does leak past the sealing surfaces to escape, preventing pressure build-up and possible damage.

British Standard Pipe Ports

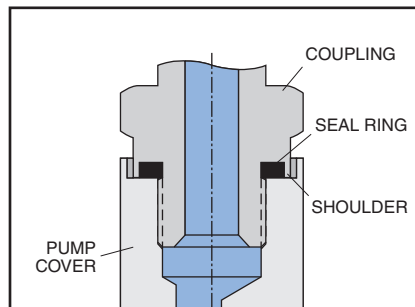

Typical port connection with British Standard Pipe (Parallel) fitting with shoulder

High-pressure pumps are available with flat face ports with British Standard Pipe (B.S.P.) parallel threads (BS 2779 or ISO 228), ideal for use on some European applications.

The fitting forms a seal by compressing a flat elastomer ring on a machined spotface surface. There are several sealing methods for these ports.

The recommended fitting has a recessed seal cavity formed by a shoulder on the underside of the flanged wrench flat (Voss "Peflex", Form B Shoulder Seal; or Parker Type E, "Elastic" Seal; or equivalent).

B.S.P. ports are not recommended for operation above 10 000 psi (700 bar). Contact the fitting manufacturer, to ensure the selected fittings are rated for the maximum pump operating pressure.

S.A.E. 4-Bolt Flange Ports

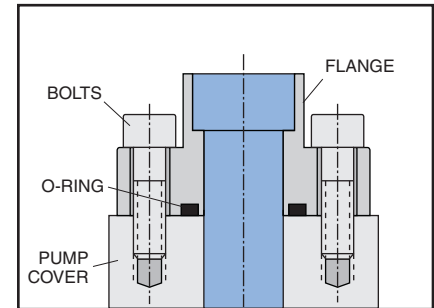

Typical S.A.E. 4-Bolt Flange port connection

Flange connections are often used for higher flows requiring larger diameter tubing. The port consists of an unthreaded port with four bolt holes in a rectangular pattern on a machined face around the port (S.A.E. J518).

A typical fitting consists of a flanged head with a welded tube and a captive flange with bolt holes. A seal is formed by an o-ring in the groove on the underside mounting surface of the flange head. As the flange bolts are alternately tightened, the o-ring is compressed between the flange head and the machined face on the pump.

To make mounting easier in tight spaces a two-piece split-flange is often used.

Hydraulic Products Used with Confidence Throughout the World



Dynex manufactures hydraulic components and systems sold worldwide for over 45 years. These products provide increased life and performance essential in critical environments. Demanding conditions include high pressure, dirty environments, contamination, special fluids, extreme temperature ranges and long, difficult duty cycles.

Products include piston pumps rated to 20 000 psi (1380 bar), directional and pressure control valves rated to 15 000 psi (1040 bar), heavy-duty piston motors, low-speed high-torque (LSHT) vane motors, electrohydraulic proportional actuators, and standard power units or specialized hydraulic systems.

Download Dynex Product Specifications!

www.dynexhydraulics.com

Go!

DYNEX
High Pressure Hydraulics

USA Headquarters

770 Capitol Drive
Pewaukee, WI 53072
Tel: 262-691-2222
FAX: 262-691-0312
E-mail: sales@dynexhydraulics.com

Power Units & Systems

54 Nickerson Road
Ashland, MA 01721
Tel: 508-881-5110
FAX: 508-881-6849
E-mail: ashland@dynexhydraulics.com

European Sales

Unit C5 Steel Close, Little End Road,
Eaton Socon, Huntingdon,
Cambs. PE19 8TT United Kingdom
Tel:+44 (0) 1480 213980 FAX:+44 (0) 01480 405662
E-mail: sales@dynexhydraulics.co.uk