

A class apart in today's hydraulics industry

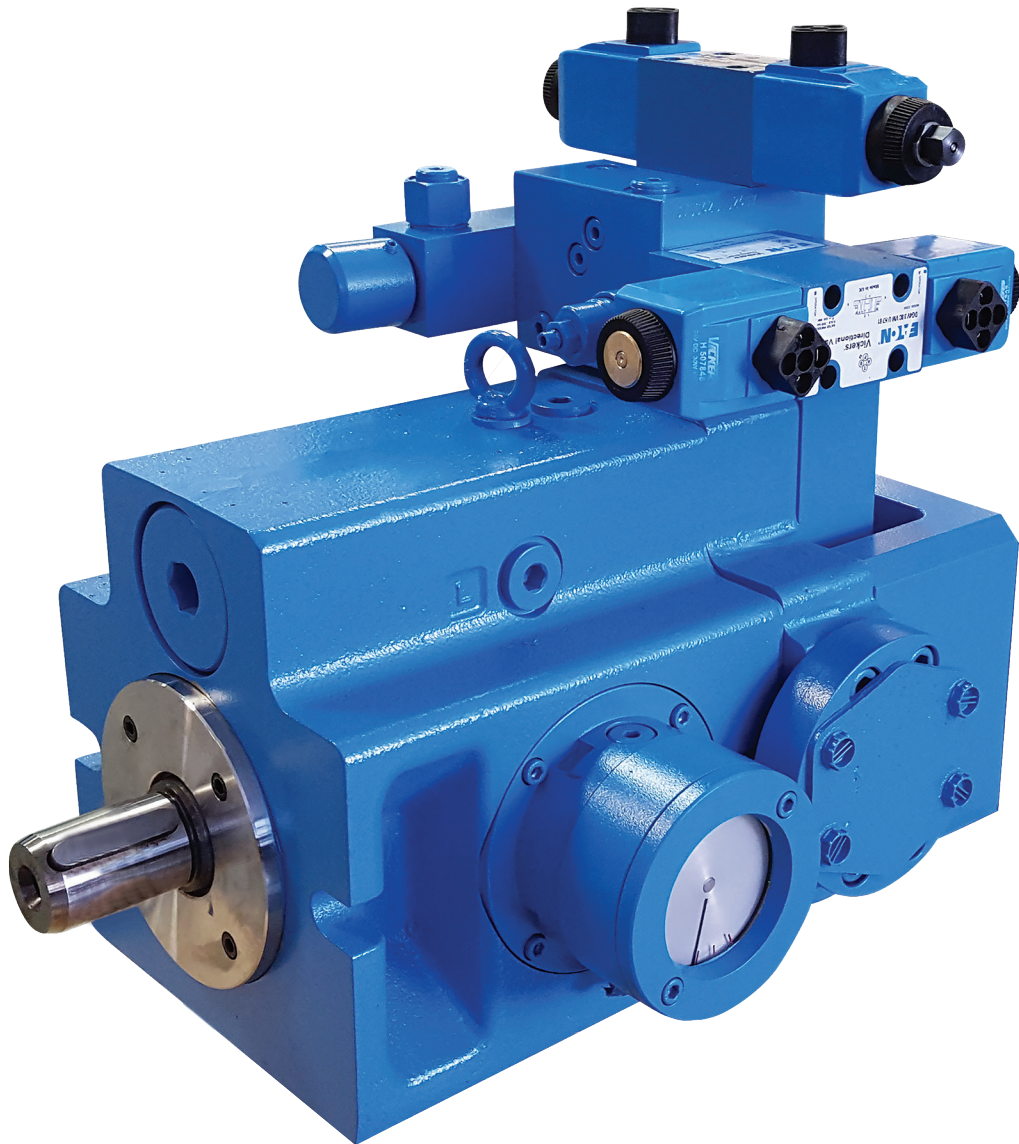

EATON

Powering Business Worldwide

Table of contents

Description	Page No.
Introduction	3
Pump model code	4-5
Basic pumps	4
ST control	5
Pump specification	6-7
Metric	6
US	7
Pump dimensions	8 - 14
PVX 066 Pump dimension	8
PVX 090 Pump dimension	9
PVX 130 Pump dimension	10
PVX 180 Pump dimension	11
PVX 250 Pump dimension	12
Controls option - ST	13
ST control amplifier card ER9.3 features & benefits	13
Application data and fluid recommendations	14
Installation and start-up	15

General description

- Axial piston pumps with swash plate design for reliable operation and long life.
- Pressure up to 420 bar.
- Rated speed up to 1800 rev/min. Higher speeds possible.
- Oversize shafts and bearings.
- Rotating and pressure- loaded parts are pressure balanced.
- Through-drive enables multiple pump installations from a single shaft. Multiple pump combinations are also available.
- Integrated pilot pump, filter and pressure relief valves available.
- Modular design gives these pumps a wide range of applications.
- Fast response times.

Available displacement sizes

- 066 cm³/rev (4.1 in³/rev)
- 090 cm³/rev (5.5 in³/rev)
- 130 cm³/rev (8.0 in³/rev)
- 180 cm³/rev (11.0 in³/rev)
- 250 cm³/rev (15.3 in³/rev)

Typical applications

- Test-rigs and simulators
- Marine
- Offshore
- Materials handling and recycling
- Timber machinery
- Chemical industry
- Pulp and paper
- Sugar mills
- Tunnel boring
- Power generation
- Primary metals including steelworks, forging and extruding

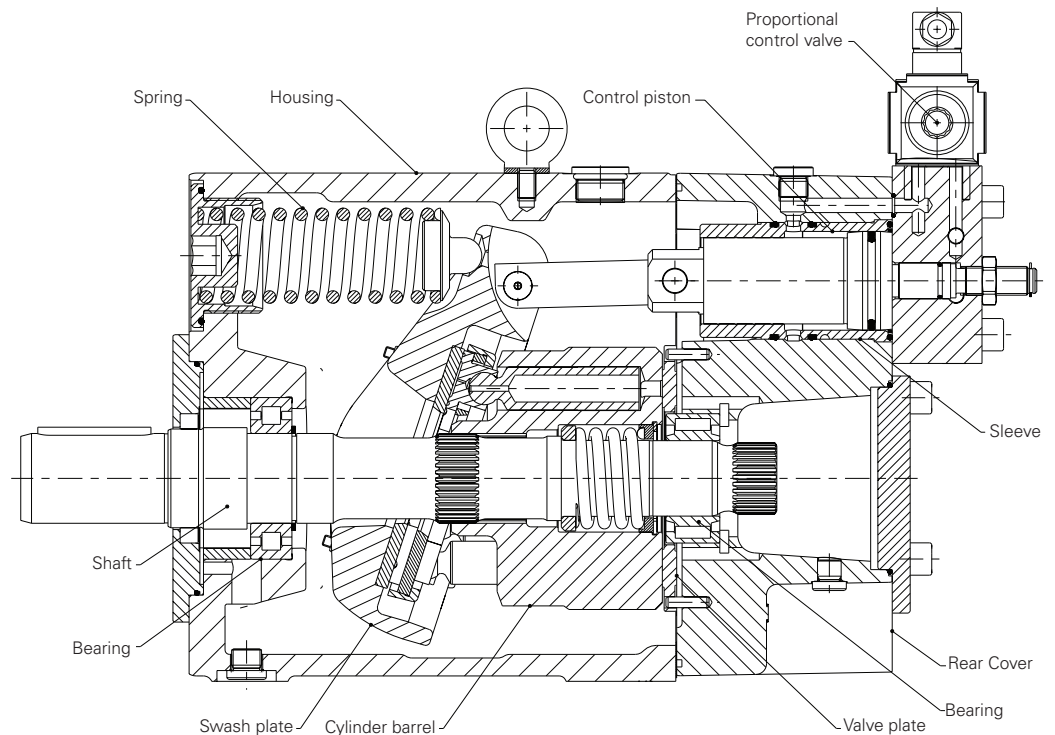

Typical section of open loop PVX pump with ST Control

 Dimensional data is subject to change without notice.

PVX Pump model code

Open Loop Piston Pumps

- Preferred standard option
- Other standard option
- Special offer on request
- x Not applicable or available

"X" Series - basic pump

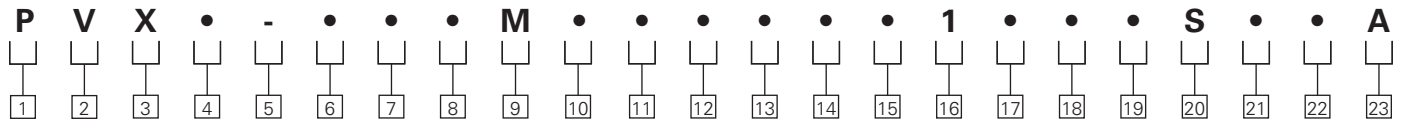

		Pump size				
		66	90	130	180	250
1	Pump					
P -	Open loop pumps	●	●	●	●	●
2	Displacement					
V -	Variable	●	●	●	●	●
3	Pump series					
X -	"X" series	●	●	●	●	●
4	Configuration					
S -	Single unit	●	●	●	●	●
5	Separator					
●		●	●	●	●	●
6 7 8	Displacement cm³/rev (in³/rev)					
066 -	066 cm³/rev (4 in³/rev)	●				
090 -	090 cm³/rev (5.5 in³/rev)		●			
130 -	130 cm³/rev (8 in³/rev)			●		
180 -	180 cm³/rev (11 in³/rev)				●	
250 -	250 cm³/rev (15.3 in³/rev)					●
9	Basic standards					
M -	Metric	●	●	●	●	●
10 11	Mounting Flange					
02 -	ISO 3019/2-125A2HW	●	●			
04 -	ISO 3019/2-160A2HW			●	●	
06 -	ISO 3019/2-200A2HW					●
12	Rotation direction					
R -	Clockwise	●	●	●	●	●
L -	Anticlockwise	○	○	○	○	X
13	Maximum displacement screw					
0 -	Displacement adjusting screw with control ST....A"0".... 1)	●	●	●	●	●
	with control ST....A"4"....	●	●	●	●	●
	with control ST....A"5".. or ..A"6"..	X	X	X	X	X
4 -	Fixed mechanical stop ring side A	○	○	○	○	○
5 -	Fixed mechanical stop ring side B	○	○	○	○	○
6 -	Fixed mechanical stop ring side A & B	○	○	○	○	○

Note: Customer adjustment required
 4 used as max. volume adjustment side A
 5 used as min. volume stop side A
 (Variable min. adj. Stop by Screw NOT available)
 *For explanation of option „0“ „6“ refer to model-code position. 30

		Pump size				
		66	90	130	180	250
14 15	Thru drive options					
00 -	None	●	●	●	●	●
0A -	SAE A	○	○	○	○	○
0B -	SAE B	○	○	○	○	○
0C -	SAE C	○	○	○	○	○
0P -	Pilot pump (8cm³/rev)	○	○	○	○	○
16	Main ports					
1 -	SAE ports-metric bolts	●	●	●	●	●
17	Main port orientation					
A -	Axial (in-line rear)	○	○	○	○	○
R -	Radial (side ports)	●	●	●	●	●
18 19	Main drive shaft end					
01 -	ISO straight key	●	●	●	●	●
02 -	ISO spline	○	○	○	○	○
20	Drive shaft seal configuration					
S -	Single shaft seal	●	●	●	●	●
21	Seal material					
V -	FKM	●	●	●	●	●
C -	Special shaft seal, for HFC fluids	○	○	○	○	○
F -	FKM + front bearing flushing prepared	○	○	○	○	○
K -	FKM with HP lubrication	○	○	○	○	○
22	Yoke position indicator					
P -	Position sensor	○	○	○	○	○
M -	Sensor with visual indicator	●	●	●	●	●
23	Surface coating					
A -	Primer blue ▼	●	●	●	●	●
0 -	Rust inhibitor oil ▼ Other finishes on request.	○	○	○	○	○

- Preferred standard option
- ◉ Other standard option
- Special offer on request
- x Not applicable or available

PVX Pump model code

Open Loop Piston Pumps

"X" Series - ST control

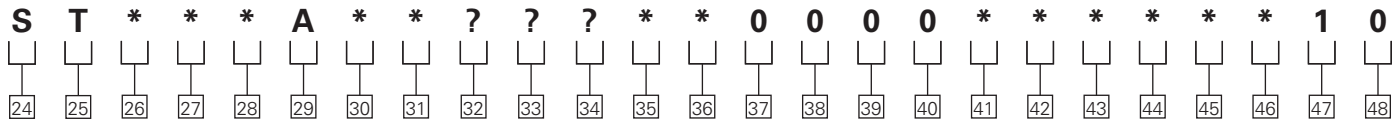

		Pump size				
		66	90	130	180	250
24 25	Control type					
ST -	EL. Proportional valve displacement control	●	●	●	●	●
26	Displacement adjustment option					
A -	with CETOP 3 interface (no valve)	◉	◉	◉	◉	◉
C -	With CETOP3 Proportional valve	●	●	●	●	●
27 28	Electronic controls					
00 -	Without electronics	○	○	○	○	○
03 -	With ER9.3 amplifier card	●	●	●	●	●
29	Yoke displacement zone					
A -	Single side of center "A"	●	●	●	●	●
30	Extra functions					
0 -	Without additional options	●	●	●	●	●
4 -	Pressure limiter override	◉	◉	◉	◉	◉
5 -	Pressure & power limiter override	◉	◉	◉	◉	◉
6 -	Power limiter override only	◉	◉	◉	◉	◉
31	Pressure limiter control options					
0 -	Including pilot relief valve and remote port option	●	●	●	●	●
F -	Remote port only	◉	◉	◉	◉	◉
K -	Proportional relief valve	◉	◉	◉	◉	◉
32 33 34	Power control setting options					
000	No power limiter override					
???	KW at 1500 RPM*	●	●	●	●	●
35	Pilot oil filter					
0 -	Without filter	●	●	●	●	●

		Pump size				
		66	90	130	180	250
36	Pilot oil supply					
A -	Internal pilot oil supply only	●	●	●	●	●
B -	External pilot oil supply only	◉	◉	◉	◉	◉
C -	Internal & external pilot oil supply by check valve	◉	◉	◉	◉	◉
37	Position monitoring (ES)					
0 -	Not required for this control type	X	X	X	X	X
38	Electric motor type (ES)					
0 -	Not required for this control type	X	X	X	X	X
39	Control voltage of venting valve					
0 -	Not required for this control type	X	X	X	X	X
40 41 42 43	Customer adjustment specification					
0000 -	None (standard setting as shown in below table)	●	●	●	●	●
???? -	Yes (final number will be assigned by Eaton) specify in detail separately	◉	◉	◉	◉	◉
44 45 46	Special feature					
000 -	None	●	●	●	●	●
???	Defined by Eaton	◉	◉	◉	◉	◉
47 48	Design number					
10 -	Design number	●	●	●	●	●

*Only if extra function power limiter override is selected

	Unit	Standard adjustment	Customer adjustment	Remarks
All revolution adjustment below set at	RPM	1500	-	-
Max. Mechanical stop side A	l/min	Qmax	-	-
Max. Software-stop by control side A	l/min	Qmax	El. Card adjustment done by customer	Refer to E. card manual
Pressure Override side A	bar	90	-	-

Notes:

- ST control requires a min. operation pressure of > 25 bar for operation. For internal pilot oil supply it must be assured that this load pressure can be provided. Below this min. pressure value pump will automatically go on max. stroke.
- Pressure level for external pilot oil supply should be equal or more than 60 bar

Pump specifications

Metric

Model			66	90	130	180	250
Design			Swashplate - Axial piston pump				
Type of mounting			Flange or foot-mounted. Combination units foot mounted only				
Pipe connection Flange							
ISO 6162-1 (SAE J518 code 61)	B	psi	P38M (1 1/2" - 500)	P51M (2" - 500)	P64M (2 1/2" - 500)	P64M (2 1/2" - 500)	P89M (3 1/2" - 500)
ISO 6162-2 (SAE J518 code 62)	A		P25M (1" - 6000)	P25M (1" - 6000)	P25M (1" - 6000)	P32M (1 1/4" - 6000)	P32M (1 1/4" - 6000)
Direction of rotation			Clockwise, Counterclockwise on request				
Mounting altitude			Horizontal, other mounting options are available on request				
Ambient temperature range	Min Max	°C	-20 50				
Weight	M	Kg	55	75	106	114	212
Moment of inertia	J	Kg m ²	0.016	0.016	0.045	0.045	0.146

Hydraulic characteristics

Rated pressure (100% duty cycle)	p _N	bar	350				
Inlet pressure	p _{1_min} p _{1_max}	bar	0.85 abs 10	0.85 abs 10	0.95 abs 10	0.95 abs 10	1.0 abs 10
Maximum pressure to ISO 5598:2008	p _{2_max}	bar	420				
Hydraulic fluid			Hydraulic oil to DIN 51524 part 2. See fluid recommendations in application data.				
Hydraulic fluid temperature range	min max	°C	-25 (on start up) 90				
Viscosity range for continuous operation	min max	cSt	10 75				
Maximum permissible start viscosity	max	cSt	1000				
Cleanliness	ISO 4406		18/15/13				
Maximum geometric displacement	V _g	cm ³ /rev	66	90	130	180	250
Speed range	n _{min} n _{max}	rev/min	150 1800				
Case pressure (over pressure)	p _{case}	bar					
n = 1200 rev/min			3.5	3.5	3.2	3.2	2.8
n = 1500 rev/min			2.7	2.7	2.5	2.5	2.1
n = 1800 rev/min			2.2	2.2	2.0	2.0	1.7

Drive

Driving torque (p _N =350bar, V _g at 1500 rev/min, η = 100%)	M _{1_Single}	Nm	367	501	724	1002	1392
Power consumption (p _N =350bar, n = 1500 rev/min, η = 100%)	P _{1_Single}	kW	57,8	78,8	113,8	739,5	1027

Combination units

Maximum driving torque limited to splined shaft only - comb. unit	M1 Comb.	Nm	2x367	2x501	2x724	2x1002	2x1392
---	----------	----	-------	-------	-------	--------	--------

Pump specification

US

Model			66	90	130	180	250
Design			Swashplate - Axial piston pump				
Type of mounting			Flange or foot-mounted. Combination units foot mounted only				
Pipe connection Flange							
ISO 6162-1 (SAE J518 code 61)	B	psi	P38M (1 1/2" - 500)	P51M (2" - 500)	P64M (2 1/2" - 500)	P64M (2 1/2" - 500)	P89M (3 1/2" - 500)
ISO 6162-2 (SAE J518 code 62)	A		P25M (1" - 6000)	P25M (1" - 6000)	P25M (1" - 6000)	P32M (1 1/4" - 6000)	P32M (1 1/4" - 6000)
Direction of rotation			Clockwise, Counterclockwise on request.				
Mounting altitude			Horizontal, other mounting options are available on request				
Ambient temperature range	Min Max	°F	-4 122				
Weight	M	lb	121	165	234	251	467
Moment of inertia	J	lb ft ²	0.38	0.38	1.068	1.068	3.465
Hydraulic characteristics							
Rated pressure (100% duty cycle)	p _N	psi	5000				
Inlet pressure	p1 _{min} p1 _{max}	psi	12.3 145	12.3 145	13.8 145	13.8 145	14.5 145
Maximum pressure to ISO 5598:2008	p2 _{max}	psi	6000				
Hydraulic fluid			Hydraulic oil to DIN 51524 part 2 See fluid recommendations in application data				
Hydraulic fluid temperature range	min max	°F	-13 (on startup) 194				
Viscosity range for continuous operation	min max	cSt	10 75				
Maximum permissible start viscosity	max	cSt	1000				
Cleanliness	ISO 4406		18/15/13				
Maximum geometric displacement	V _g	in ³	4.0	5.5	8.0	11.0	15.3
Speed range	n _{min} n _{max}	rev/min	150 1800				
Case pressure (over pressure)	p _{case}	psi					
n = 1200 rev/min			50	50	46	46	40
n = 1500 rev/min			39	39	36	36	30
n = 1800 rev/min			32	32	29	29	24
Drive							
Driving torque (p _N = 5075psi, V _g at 1500 rev/min, η = 100%)	M1 _{Single}	lbf*ft.	271	369	534	739	1027
Power consumption (p _N = 5075psi, η = 1500 rev/min, η = 100%)	P1 _{Single}	hp	77.5	105.5	152.5	211	293
Combination units							
Maximum driving torque limited to splined shaft only - comb. unit	M1 Comb.	lb*ft.	2x271	2x369	2x534	2x739	2x1027

Pump dimensions

PVX 066 STC03A0

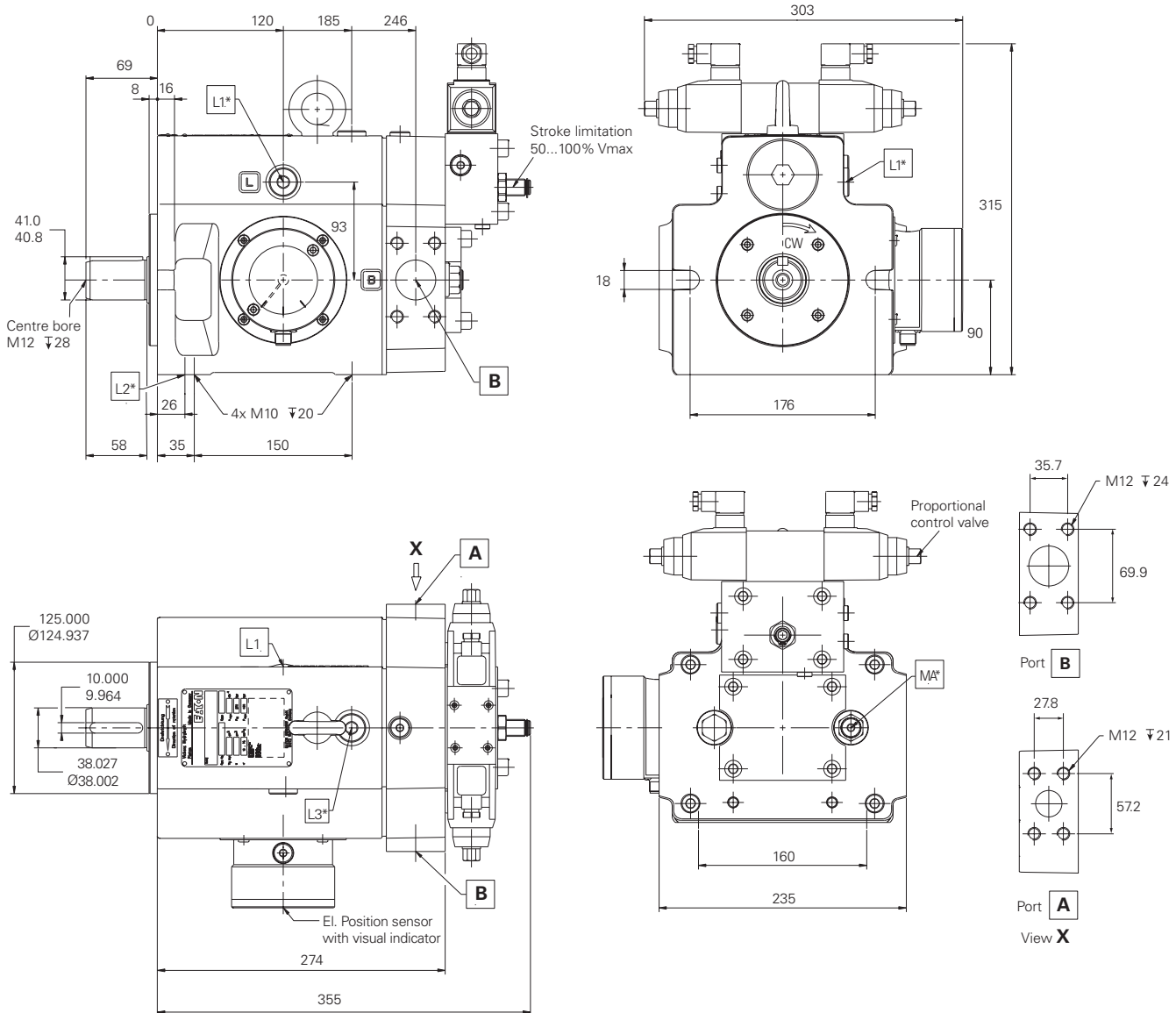

A System pressure port
ISO 6162-2 P25M
(SAEJ 518
Code 62 - 1" - 6000 PSI)

B Inlet port
ISO 6162-1 P38M
(SAEJ 518
Code 61 - 1 1/2" - 500 PSI)

L1 Drain port M-22x1.5
(according to mounting
position use upper port)

L2 M18x1.5-12 Deep
supplementary drain
or bleed plug. Must be
drained in addition to L1
if pump is installed
with the shaft input end
pointing upwards

L3 Oil filling 7/8"-14 UNF
or bleed plug

MA Gauge port system
pressure G 1/4"

...* Connection with plug

Pump dimensions

PVX 090 STC03A0

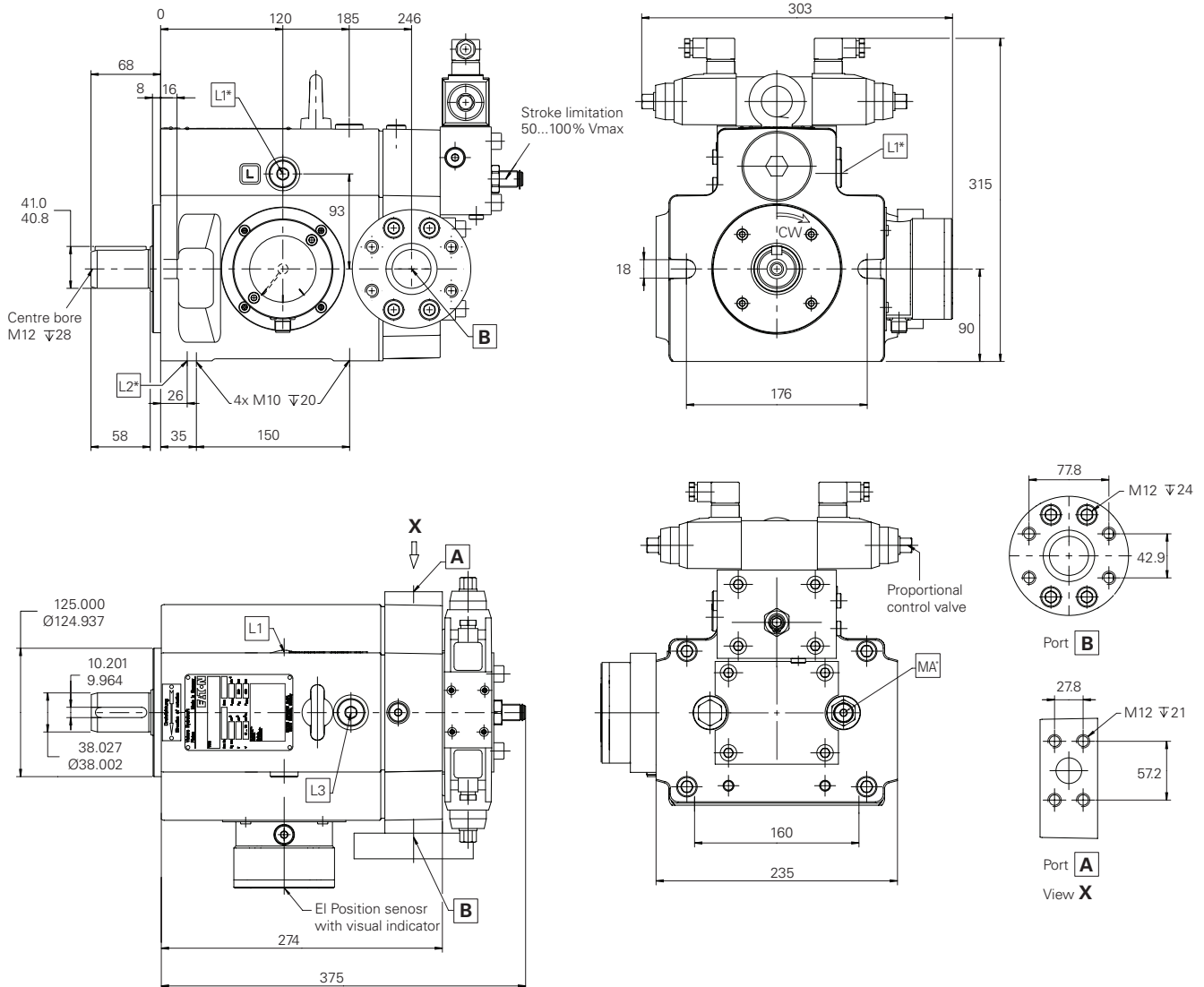

A System pressure port
ISO 6162-2 P25M
(SAEJ 518
Code 62 - 1" - 6000 PSI)

B Inlet port
ISO 6162-1 P51M
(SAEJ 518
Code 61 - 2" - 500 PSI)

L1 Drain port M22x1.5
(according to mounting
position use upper port)

L2 M18x1.5-12 Deep
supplementary drain
or bleed plug. Must be
drained in addition to L1
if the pump is installed
with the shaft input end
pointing upwards

L3 Oil filling $\frac{7}{8}$ "-14 UNF or
bleed plug

MA Gauge port system
pressure G $\frac{1}{4}$ "

...* Connection with plug

Pump dimensions

PVX 130 STC03A0

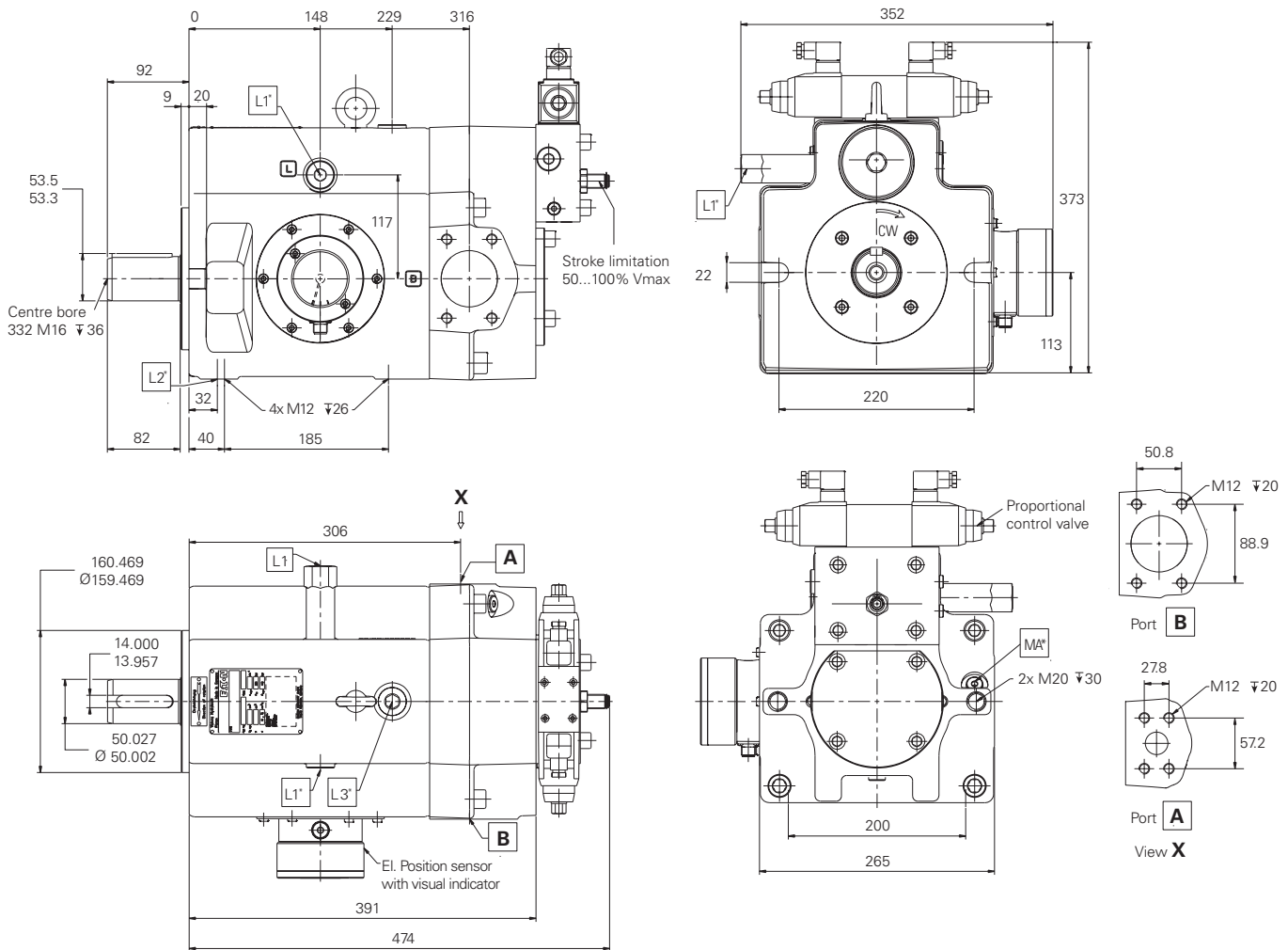

A System Pressure port
ISO 6162-2 P25M
(SAEJ 518
Code 62 - 1" - 6000 PSI)

B Inlet Port
ISO 6162-1P64M
(SAEJ 518
Code 61 - 2 1/2" - 500 PSI)

L1 Drain port M26x1.5,
(according to mounting
position use upper port)

L2 M18x1.5-12 Deep
supplementary drain
or bleed plug. Must be
drained in addition to L1
if the pump is installed
with the shaft input end
pointing upwards

L3 Oil filling 1 1/16"-12
or bleed plug

MA Gauge port system
pressure G 1/4"

...* Connection with plug

Pump dimensions

PVX 180 STC03A0

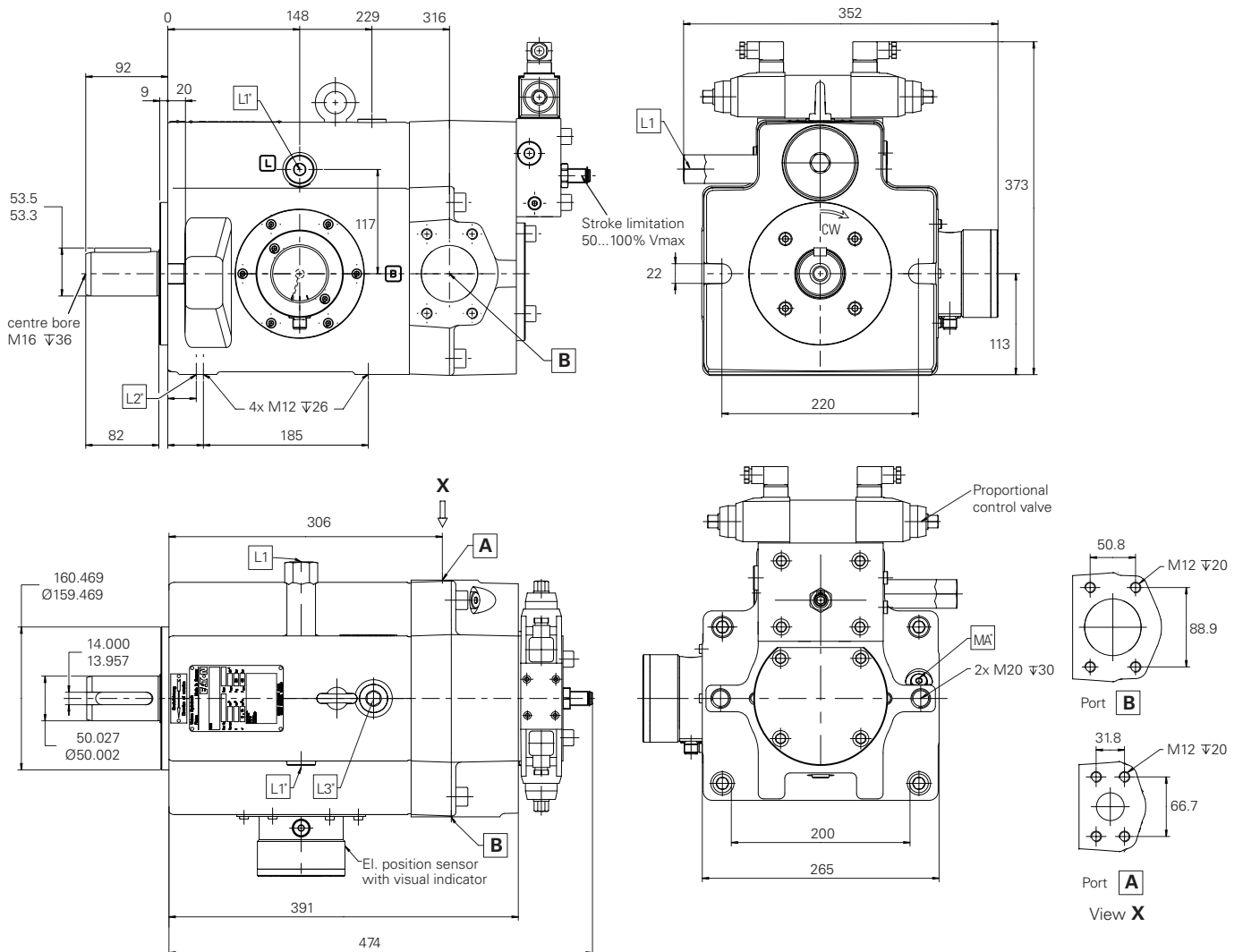

- A** System pressure port
ISO 6162-2 P32M
(SAEJ 518
Code 62 - 1 1/4" - 6000 PSI)
- B** Inlet port
ISO 6162-1 P64M
(SAEJ 518
Code 61 - 2 1/2" - 500 PSI)

- L1** Drain port M26x1.5,
(according to mounting
position use upper port)

- L2** M18x1.5-12 deep
supplementary drain,
or bleed plug. Must be
drained in addition to L1
if the pump is installed
with the shaft input end
pointing upwards

- L3** Oil filling 1 1/16" -12
or bleed plug
- MA** Gauge port system
pressure G 1/4"
- ...*** Connection with plug

Pump dimensions

PVX 250 STC03A0

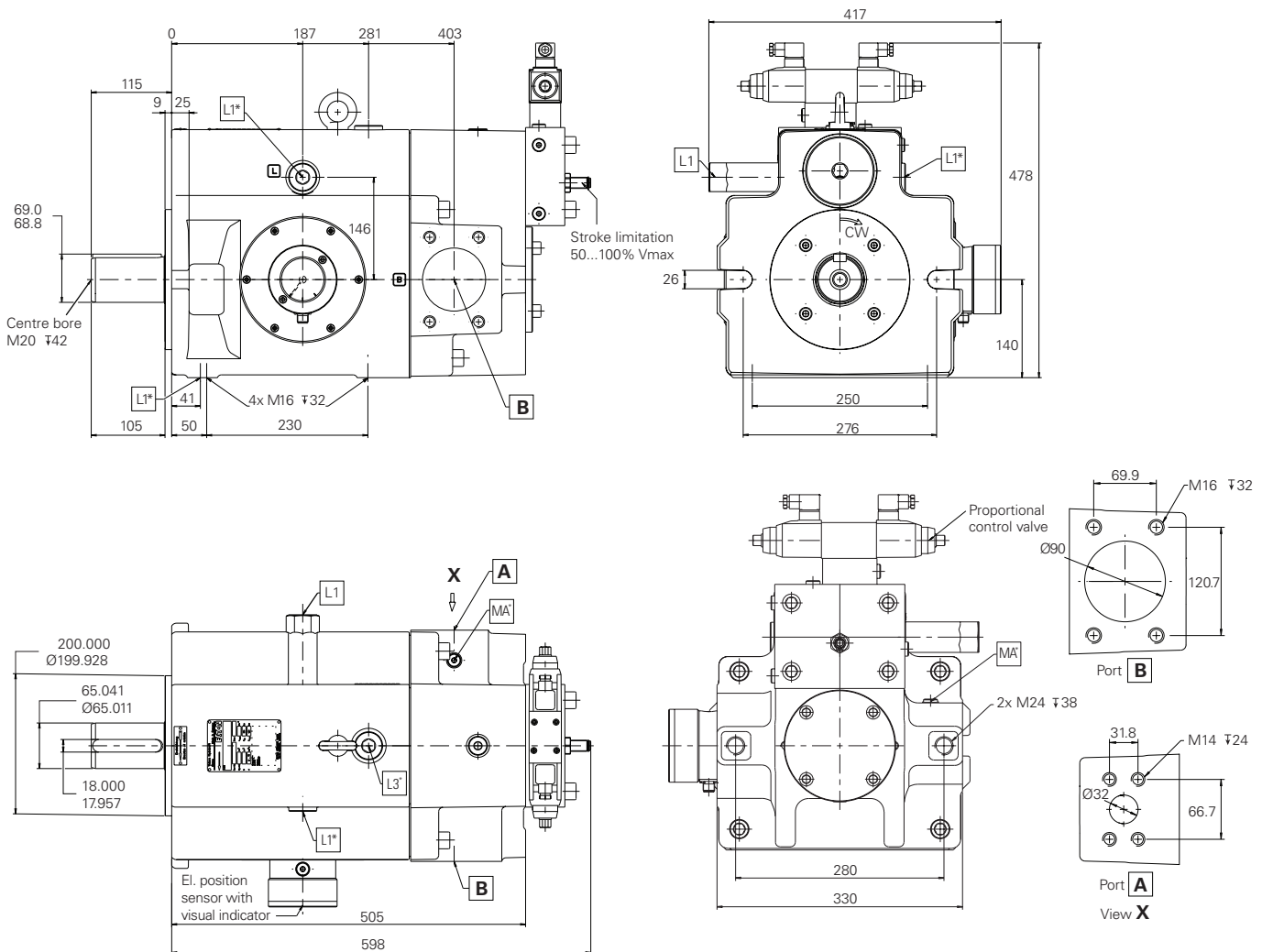

A System pressure port
ISO 6162-2 P32M
(SAEJ 518
Code 62 - 1 1/4" - 6000 PSI)

B Inlet Port
ISO 6162-1 P89M
(SAEJ 518
Code 61 - 3 1/2" - 500 PSI)

L1 Drain port M33x2,
(according to mounting
position use upper port)

L2 M18x1.5-12 Deep
supplementary drain,
or bleed plug. Must be
drained in addition to L1
if the pump is installed
with the shaft input end
pointing upwards

L3 Oil filling 1 5/16"-12 UNF
or bleed plug

MA Gauge port system
pressure G 1/4"

...* Connection with plug

"X" series - open loop pump

The ST control operates a hydrostatic drive and works without throttle losses within electrically adjustable limits. This is done by controlling delivery flow with electrical swashplate angle feedback (electric closed-loop control). All control values are recorded as an electrical signal and lead back to the control card.

The proportional valve and servo piston transform the output signal of the control card to the desired setting. This results in a very precise and dynamic control. Pressure limiter override available on request. Power limiter override not available (for such and other options please refer to PVW series).

As an additional option the maximum (and/or minimum) flow can be limited by a spacer inside the control cylinder (position number 13 in model coding, options 4, 5 or 6 in combination with customer adjustment specifications position 40-43 for the set values).

This solution is also recommended for very rough operating conditions and the need of a very exact repeatability over a long time period. The setting must be defined before ordering and cannot be modified during operation.

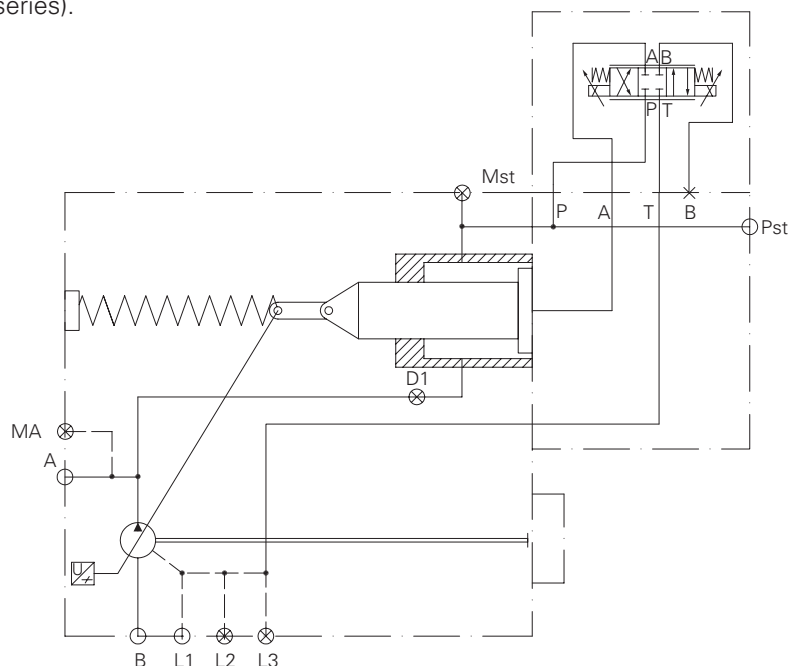
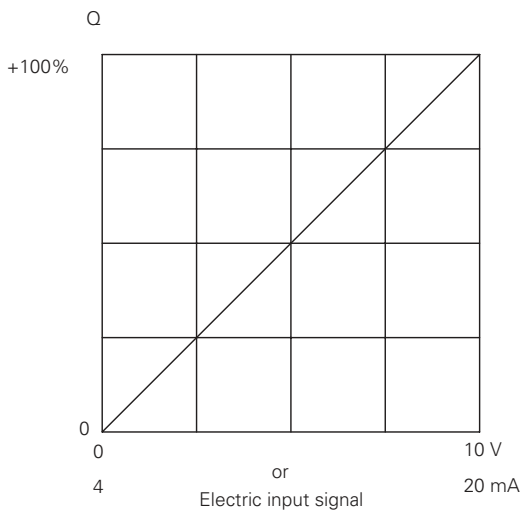

PVX response times ST - control

Proportional valve	Pilot oil flow	Control electronics (Amp. Card)	Response time ¹⁾	Unit size cm ³	Servo piston		
			[ms]		Diameter mm (in)	Stroke mm (in)	Volume cm ³ (in ³)
KDG4V3-2C20NMUH760 (CETOP 3)	Internal	ER 9.3-10	250	066 / 090	40/30 (1.57/1.18)	28 (1.10)	15,4 (0.939)
			350	130 / 180	55/48 (2.16/1.88)	35 (1.37)	43,5 (2.654)
			550	250	70/60 (2.75/2.36)	43,5 (1.71)	81 (4.942)

¹⁾Response time is depending on pressure and flow provided to control piston. Shown values are average values with internal pilot oil supply.

ST control amplifier card ER9.3 features & benefits

- Low cost version of SP control
- Neutral/starting position by spring: max displacement
- Pilot pump not required
- With control piston ratio 4:1, spring centering at max flow
- With internal or external pilot oil supply
- Reduced installation space
- Universal, full digital amplifier card ER 9.x
- 2 x 14 bit analog inputs, 0- +/-10V or 4-20mA
- 4 recallable digital adjustable set points
- Preset with parameters for SP/ST-control
- Programmable by customer via Display on card or via RS 232 Interface (PC- Software for free)

Application data and fluid recommendations

Fluid type	Classification DIN/ISO	Rated pressure p _N (bar)	Maximum speed (rev/min) ■		Recommended seal material	Maximum operating temperature °C	Bearing life
			66-180cc	250cc			
Water Glycol ▲	HFC	250	1500 (1800)	1200 (1500)	NBR	45	25-100%
HFDR (phosphate ester based)	HFDR	350	1500	1200	FKM	60	100% ▼
HFDU (glycol based)	HFDU	350	1500	1200	FKM	60	100% ▼
HFDU (ester based)	HFDU	350	1800	1500	FKM	60	100% ▼
HEES (synthetic ester)	HEES	350	1800	1500	FKM	60	100% ▼

- See general specifications for speed limitation depending on displacement.
- ▲ For HFC operation, bearing flushing is mandatory. Highest speed only recommended at optimized application conditions.
Use Model Code 21 = "C" for seal option, and contact your Eaton Representative for validation.
Seal material can differ on an individual pump depending on specific seal function.
Bearing life with HFC fluid depends significantly on fluid temperature, cleanliness, quality, flushing and application parameters.
Typical values vary between 25% and 100% compared to mineral oil.
- ▼ Only fluids with fully saturated esters (iodine value <10) should be used.
HFDU and HEES fluids can be used at full ratings, but need to be monitored continuously to maintain quality and performance.
The following important values should always be checked:
 - Water content (<= 500 ppm)
 - Fluid cleanliness (18/15/13 per ISO 4406)
 - TAN value (no significant change from new oil)
 - Viscosity (no significant change from new oil)
 - Additives (no significant change from new oil)

Under harsh operation conditions, especially with regard to temperature and water content, ester-based HFDU and HFDR fluids are prone to hydrolysis, the resulting chemical processes and products of which could damage seal and other pump components. In general, the susceptibility to temperature and contamination is significantly higher than with standard mineral oils. In line with Eaton Germany GmbH T&C warranty conditions covering use of HFDR/HFDU/Fluids, Fluids-related damage is excluded.

Case/bearing flushing

Case and bearing flushing are mandatory for HFC fluid operation, and recommended for all other conditions where the pump is operating for longer intervals at low pressure i.e. <20 bar (<300 psi) and/ or low flow at high pressure (compensated mode).

Estimated flushing flow values at 1500 rev/min	
Pump size (cm ³ /rev)	Flushing flow (l/min)
066/090	3,5
130/180	4,5
250	6

Vertical mounting

Vertical mounting of Hydrokraft pumps is possible, but venting and lubrication of shaft bearings can require special flushing and installation procedures. For details, please refer to the Hydrokraft Application Guideline Presentation available from your Eaton Representative.

High pressure lubrication / hydrostatic balancing for yoke bearings (half-cup bearings)

High-pressure bearing lubrication and balancing (Model Code 21 = "K") is recommended for operating conditions with either high cycle frequencies (very short up/downstroke times) and/or where the swashplate is constantly maintained at a certain angle for long periods of time (compensated mode).



For details and additional information, please refer to the "HydroKraft Application Guideline Presentation" available from your Eaton Representative.

Warning:

Care should be taken that mechanical and hydraulic resonances are avoided in the application of the pump. Such resonances can seriously compromise the life and/or safe operation of the pump.

Drive data

Mounting attitude should be horizontal using the appropriate case drain ports to ensure that the case remains full of fluid at all times. Consult your local Eaton Representative if a different arrangement is required. In those cases where geometric tolerances of mounting are critical, or where specific tolerance ranges are required and not specified, consult Eaton Engineering for specific limits.

Direction of shaft rotation, viewed from the prime mover end, must be as indicated in the model designation on the pump – either right hand (clockwise) or left hand (counterclockwise). Direct coaxial drive through a flexible coupling is recommended. If drives imposing radial shaft loads are considered, please consult your Eaton Representative.

Start-up procedure

Make sure the reservoir and circuit are clean and free of dirt/debris prior to filling with hydraulic fluid. Fill the reservoir with filtered oil and fill to a level sufficient enough to prevent vortexing at the suction connection to pump inlet. It is good practice to clean the system by flushing and filtering, using an external slave pump.

Caution:

Before the pump is started, fill the case through the uppermost drain port with hydraulic fluid of the type to be used. The case drain line must be connected directly to the reservoir and must terminate below the oil level. Once the pump is started, it should prime within a few seconds. If the pump does not prime, check to make sure that there are no restrictions between the reservoir and the inlet to the pump, and that the pump is being rotated in the proper direction, and that there are no air leaks in the inlet line and connections. Also check to make sure that trapped air can escape at the pump outlet. After the pump is primed, tighten the loose outlet connections, then operate for five to ten minutes (unloaded) to remove all trapped air from the circuit. If the reservoir has a sight gage, make sure the fluid is clear – not milky.

Fluid cleanliness

Hydrokraft pumps are rated in anti-wear petroleum fluids with a contamination level of 18/15/13 per ISO 4066. Operation in fluids with levels more contaminated than this is not recommended. Fluids other than petroleum, severe service cycles, or temperature extremes are cause for adjustment of these codes. Please contact your Eaton Representative for specific duty cycle recommendation.

Eaton Hydrokraft pumps, as with any variable displacement piston pumps, will operate with apparent satisfaction in fluids up to the rating specified here. Experience has shown however, that pump and hydraulic system life is not optimized with high fluid contamination levels (high ISO cleanliness codes).

Proper fluid condition is essential for long and satisfactory life of hydraulic components and systems. Hydraulic fluid must have the correct balance of cleanliness, materials, and additives for protection against wear of components, elevated viscosity and inclusion of air.

Essential information on the correct methods for treating hydraulic fluid is included in Eaton publication 561 "Eaton Guide to Systemic Contamination Control" available from your local Eaton distributor. In this publication, filtration and cleanliness levels for extending the life of axial piston pumps and other system components are listed. Included is an excellent discussion of the selection of products needed to control fluid condition.

Eaton
Hydraulics Group USA
14615 Lone Oak Road
Eden Prairie, MN 55344
USA
Tel: 952-937-9800
Fax: 952-294-7722
www.eaton.com/hydraulics

Eaton
Hydraulics Group Europe
Route de la Longeraie 7
1110 Morges
Switzerland
Tel: +41 (0) 21 811 4600
Fax: +41 (0) 21 811 4601

Eaton
Hydraulics Group Asia Pacific
Eaton Building
4th Floor, No. 3 Lane 280 Linhong Rd.
Changning District
Shanghai 200335
China
Tel: (+86 21) 5200 0099
Fax: (+86 21) 5200 0400

Eaton
Hydraulics Group EMEA
Hydrokraft plant
Am Joseph 16
D-61273 Wehreim Germany
Tel. +49 (0)6081103-324/-286/-235
Fax. +49 (0)6081103-342