

THE PRODUCTION LINE OF HANSA-TMP

**Variable Displacement
Medium Duty Axial Piston Plug-in Motor
for Open and Closed Loop System**

**TMV 650
(2 ÷ 45 cm³/n)**



CONTENTS

General Information.....	4
Section View.....	5
Specification Data.....	6
Overall Dimensions and Ports.....	7 - 9
Shafts Mounting.....	10
Ordering Code.....	11
Valve Options.....	12 - 13
Shaft Types and Dimensions.....	14 - 15
Speed Sensors.....	16 - 17
Fluid Viscosity Limits.....	18
Basic and Application Formulas.....	19

Hydraulic Motors Type TMV 650

Variable Displacement Medium Duty Axial Piston Plug-in Motors

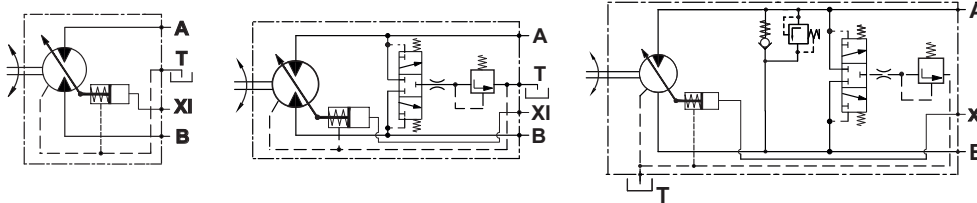

open drain line is always required

APPLICATION

- » Agricultural machines
- » Road building machines
- » Food industry machines
- » Swing drives
- » Hydraulic transmissions
- » Special vehicles

OPTIONS

- » Swash plate
- » Port options
- » Shaft options
- » Integrated valves

ADVANTAGES

- » Smooth operation
- » High power density
- » Compact size

GENERAL

Displacement,	cm ³ /n	2÷45
Max. Speed,	n/min.	3500
Max. Torque,	Nm	179
Max. Output,	kW	50
Max. Pressure Drop,	bar	280
Max. Oil Flow,	lpm	160
Min. Speed,	n/min.	500
Fluid	Mineral based - HLP(DIN 51524) or HM(ISO 6743/4)	
Temperature Range,	°C	-40÷82
Optimal Viscosity Range,	mm ² /s	12÷68
Filtration	ISO code 18/16/13 (Min. recommended fluid filtration of 10 micron)	

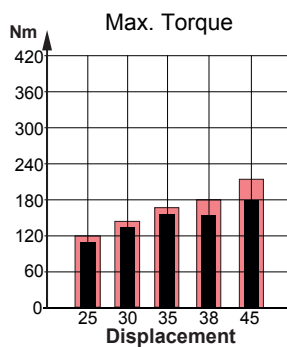

Intermittent values

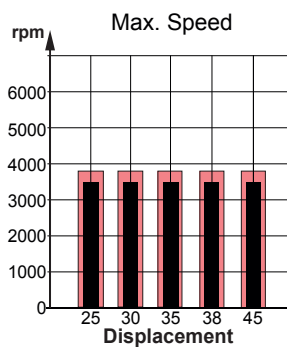

Continuous values

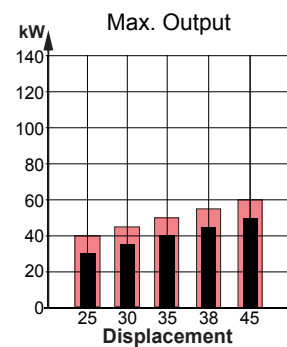

SECTION VIEW

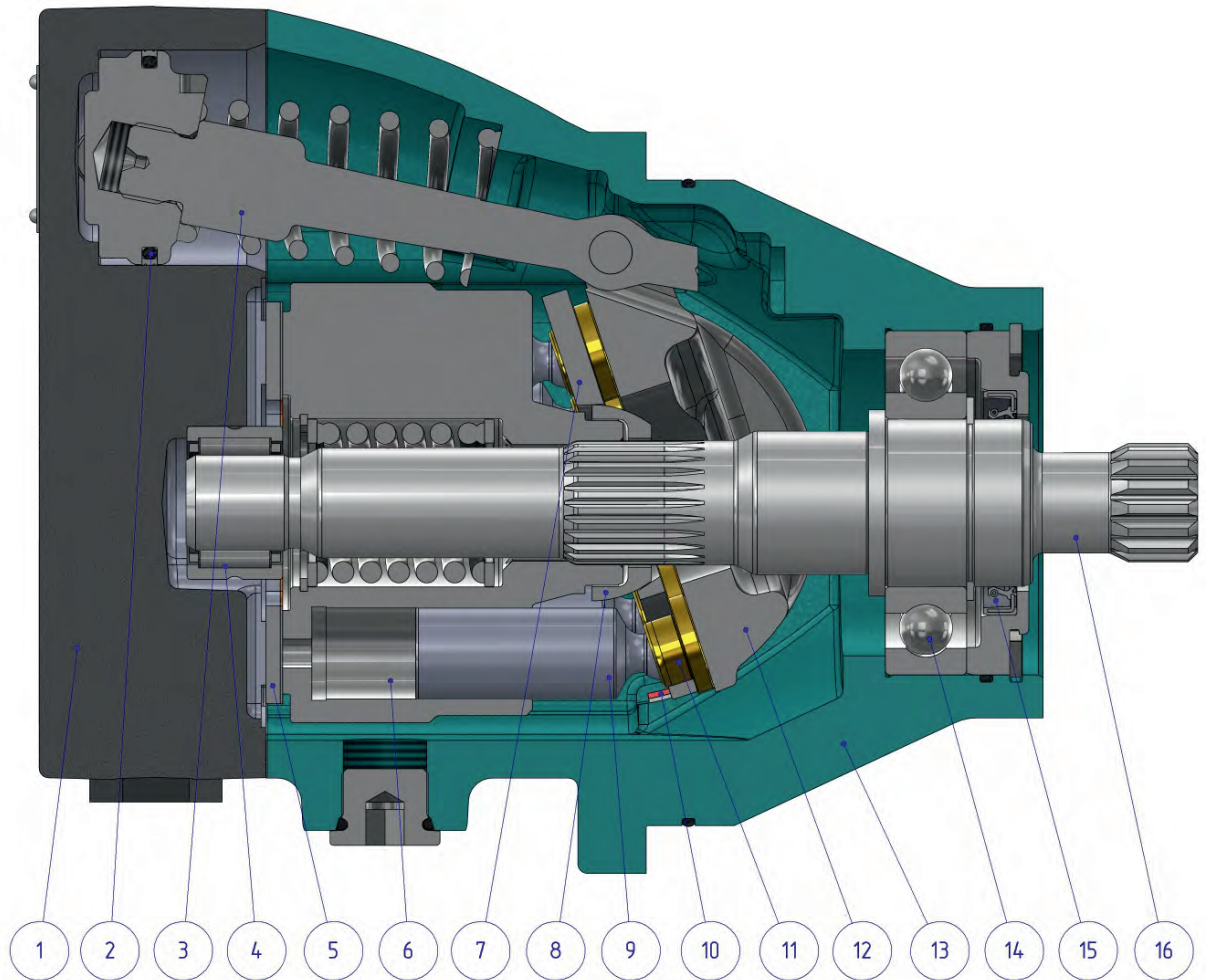

- | | |
|--|---|
| <ul style="list-style-type: none"> 1. Cast iron end cover 2. High pressure displacement control system seal 3. Displacement control system 4. Needle bearing 5. Bimetal distributor 6. Cylinder block 7. Retainer plate 8. Hardened sphere | <ul style="list-style-type: none"> 9. Pistons 10. Cradle plain bearing 11. Piston shoes 12. Hardened cradle 13. Cast iron body 14. Ball bearing 15. Shaft seal 16. Hardened shaft |
|--|---|

The medium duty design of the TMV 650 is dual displacement motor with direct control for open and closed circuits. The motor compact construction is cost effective and have got high power / weight ration. The design of the motor is maintain friendly. We using swash plate witch insure low level of pulsation and noise level.

SPECIFICATION DATA

Type		TMV 25	TMV 30	TMV 35	TMV 38	TMV 45
Max. Displacement, cm ³ /n.		25	30	35	38	45
Max. Speed at	Cont.	3500	3500	3500	3500	3500
Max. Displ. n/min.	Int.*	3900	3900	3900	3900	3900
Max. Speed at	Cont.	4000	4000	4000	4000	4000
Min. Displ. n/min.	Int.*	4500	4500	4500	4500	4500
Max. Torque, ***	Cont.	111	134	156	151	179
Nm	Int.**	119	143	167	182	215
Output,	Cont.	30	35	40	45	50
kW	Int.**	40	45	50	55	60
Max. Pressure,	Cont.	280	280	280	250	250
bar	Int.**	300	300	300	300	300
	Peak****	350	350	350	350	350
Max. Oil Flow,	Cont.	90	105	125	135	160
l/min	Int.*	100	120	140	150	180
Speed Shifting Pressure,						
Minimum,	bar	14				
Maximum,	bar	70				
Permissible Shaft Load (for standard bearing)		Fa=1000				
Max. Axial *****	N					
Max. Radial *****	N	Fr=350				
Speed Constant ***** n/min. / (l/min.)		38	31.7	27.1	25	21.1
Torque Constant ***** Nm/bar		0.35	0.43	0.502	0.544	0.645
Min. Speed,	n/min.	500				
Max. Pressure in Drain Line,	bar	5 open drain line is always required				
Weight,	kg	15.6				

* Intermittent speed (flow) is for pressure up to 210 bar.

** Intermittent load: the permissible values may occur for max. 10% of motor lifetime.

*** Theoretical torque

**** Peak load: the permissible values may occur for max. 1% of every minute.

***** The calculated max values are based on the optimal direction of the forces Fr, Fa and optimal position of the shaft.

***** The constant values are used for calculation of torque and speed with motor efficiencies $\eta_v=0.95$ and $\eta_{mh}=0.9$.

1. The recommended output power for continuous operations should not be exceeded.
2. Recommended filtration as per ISO 4406 cleanliness code 18/16/13 or better. This filtration corresponds to SAE AS 4059 8A/7B/7C. Nominal filtration - 10 micron or better.
3. Recommended a premium quality, anti-wear type mineral based hydraulic oil, HLP(DIN51524) or HM(ISO6743/4).
4. Recommended oil viscosity - 12...68 cSt or see page 18.
5. Recommended maximum system operating temperature -82°C.
6. To ensure optimum life of the motor, fill it up with fluid prior to load it and run with moderate load and speed for about 10-15 minutes.

Hint: Motor Torque = Torque Constant * Pressure Drop

Rotation Speed = Speed Constant * Oil Flow

The constant values are mentioned for rough calculations. Motor torque and rotation speed for a particular project are depending on the real operating conditions. For more detail calculations please see formulas on page 19.

Overall Dimensions and Ports

Twin ports with side control port, port size 2,3 and 4

See the port sizes at the bottom of this page

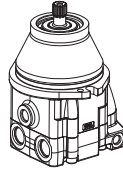

Standard Rotation
Viewed from shaft end
Port A Pressurized - CW
Port B Pressurized - CCW

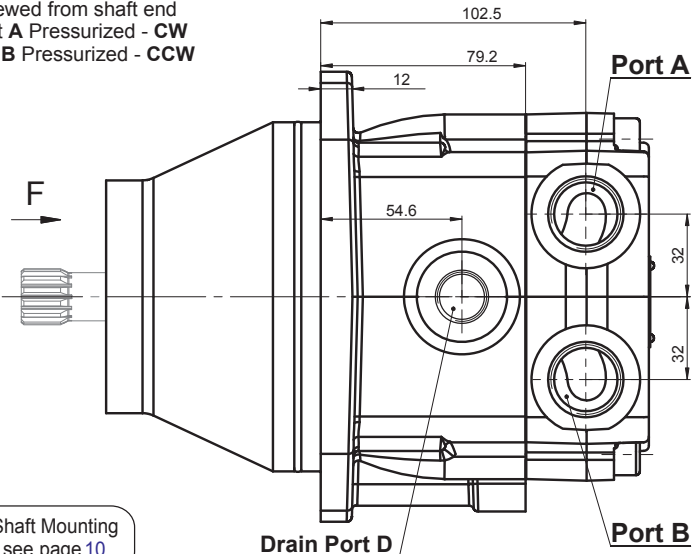
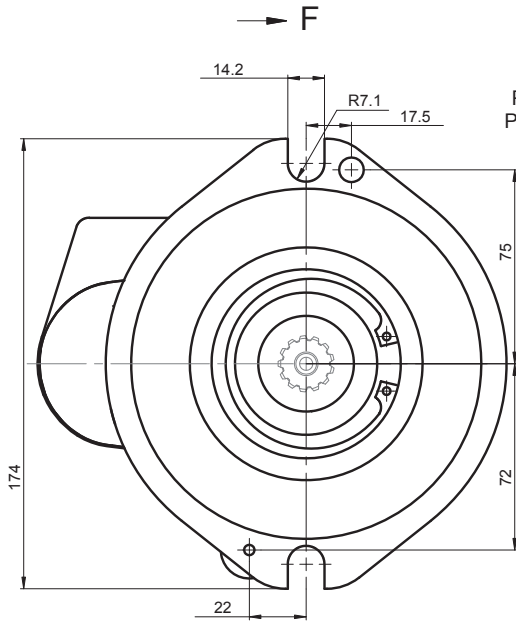

Shaft Mounting
see page 10

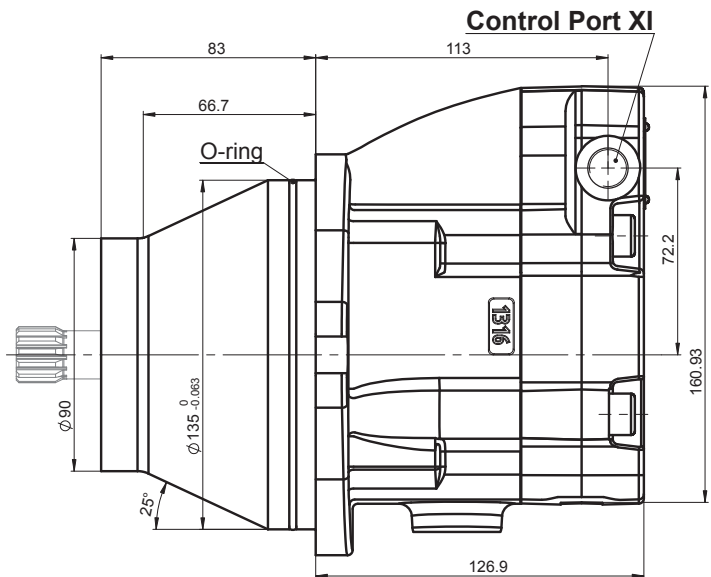
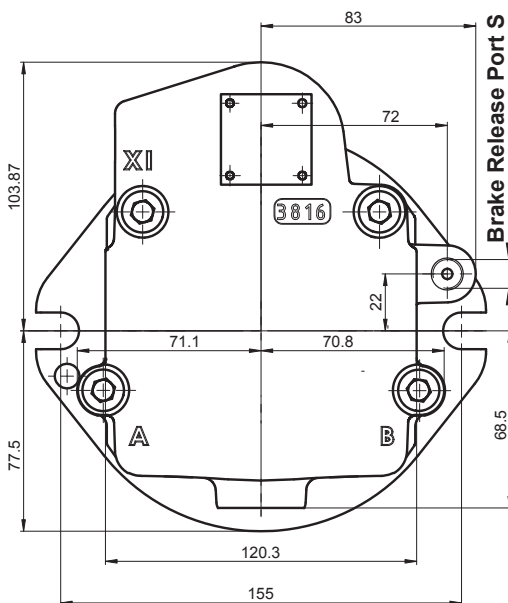

	Port Size		
	2	3	4
P_(A,B)	2xG 3/4	2xM27x2	2x1 1/16-12 UN -2B
D	G 3/4	7/8-14 UNF-2B	3/4-16 UNF-2B
XI	G 1/8	7/16-20 UNF-2B	9/16-18 UNF-2B
S	G 1/8	7/16-20 UNF-2B	7/16-20 UNF-2B

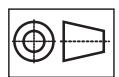

mm

Overall Dimensions and Ports

Twin ports with rear control port, port size 2,3 and 4

See the port sizes at the bottom of this page

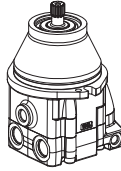

Standard Rotation
Viewed from shaft end
Port A Pressurized - CW
Port B Pressurized - CCW

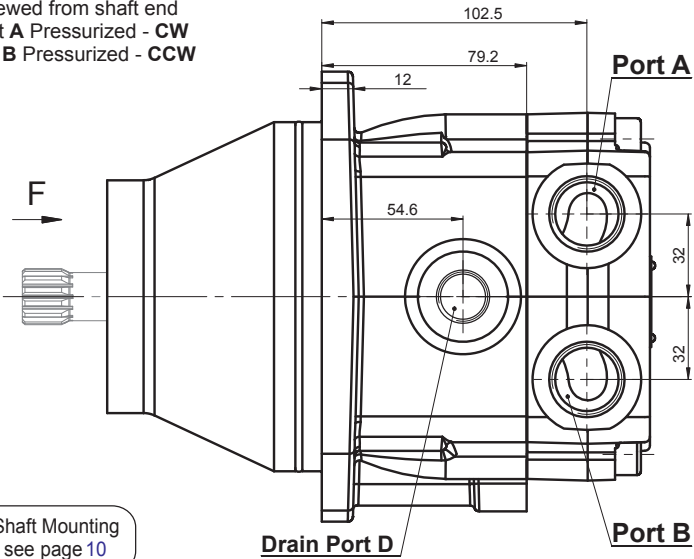
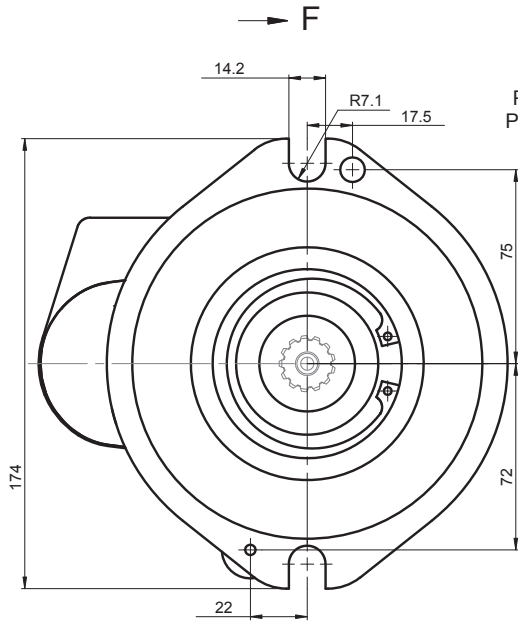

Shaft Mounting
see page 10

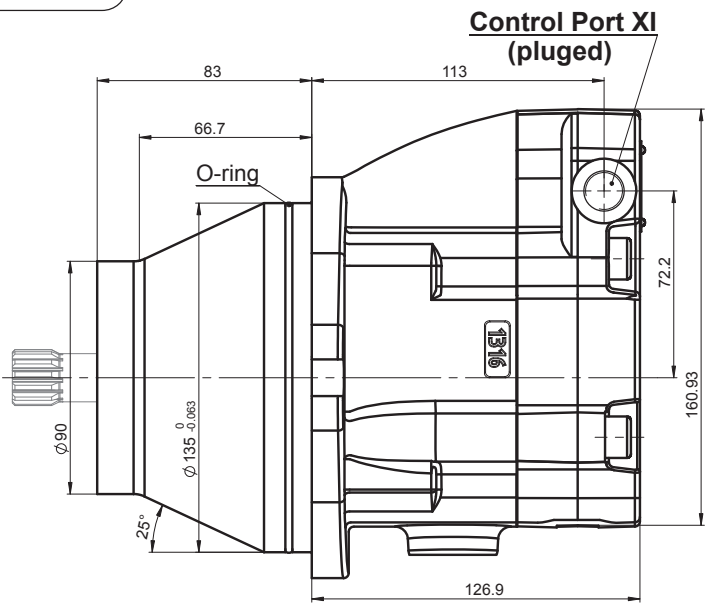
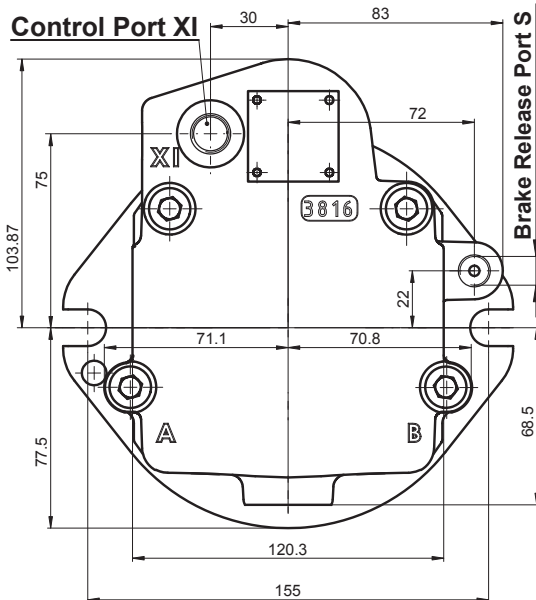

	Port Size		
	2	3	4
P _(A,B)	2xG 3/4	2xM27x2	2x1 ¹ / ₁₆ -12 UN -2B
D	G 3/4	7/8-14 UNF-2B	3/4-16 UNF-2B
XI	G 1/8	7/16-20 UNF-2B	9/16-18 UNF-2B
S	G 1/8	7/16-20 UNF-2B	7/16-20 UNF-2B

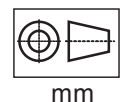

Overall Dimensions and Ports

Rear ports with rear control port, port size 2,3 and 4

See the port sizes at the bottom of this page



Standard Rotation
Viewed from shaft end
Port A Pressurized - CW
Port B Pressurized - CCW

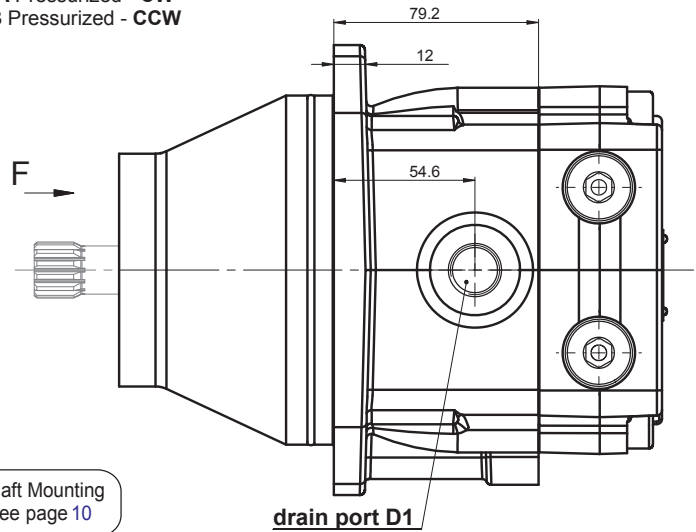
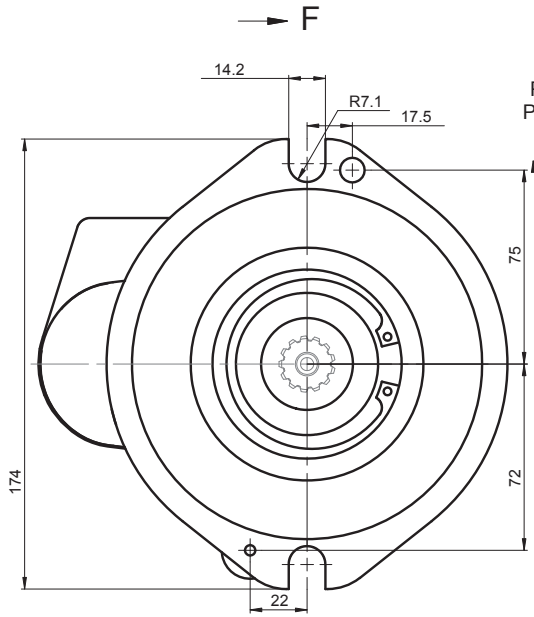

Shaft Mounting
see page 10

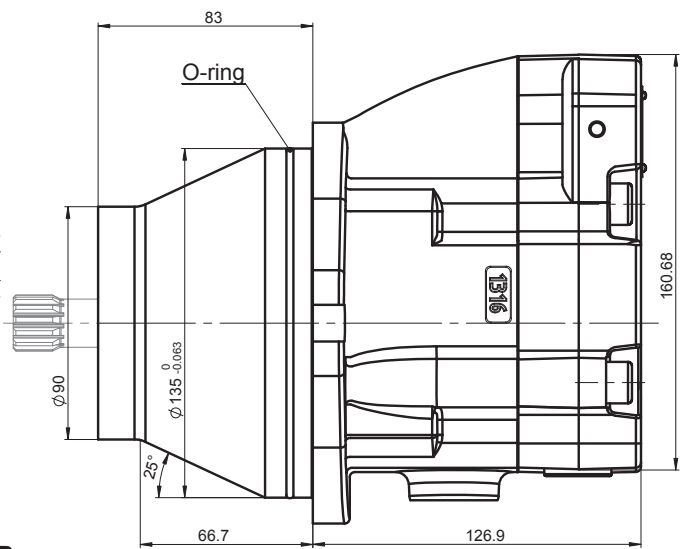
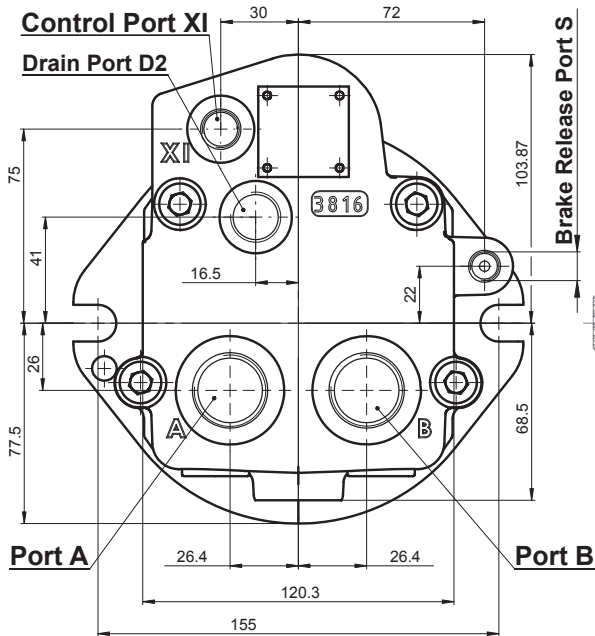

	Port Size		
	2	3	4
P_{A,B}	2xG 3/4	2xM27x2	2x1 ¹ / ₁₆ -12 UN -2B
D1	G 3/4	3/4-16 UNF-2B	3/4-16 UNF-2B
D2	G 1/2	7/8-14 UNF-2B	3/4-16 UNF-2B
XI	G 1/8	7/16-20 UNF-2B	9/16-18 UNF-2B
S	G 1/8	7/16-20 UNF-2B	7/16-20 UNF-2B

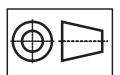

mm

Shafts Mounting

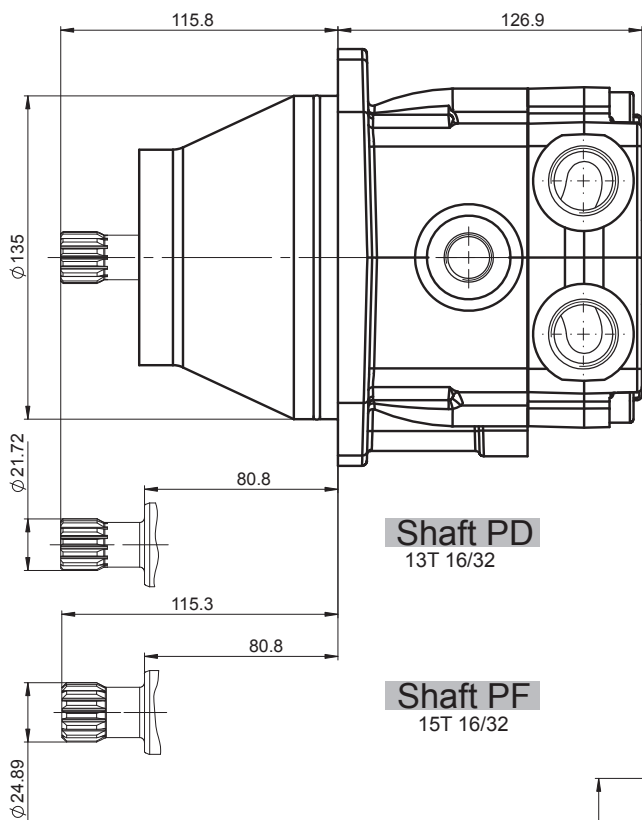

Shaft PD
13T 16/32

Shaft PF
15T 16/32

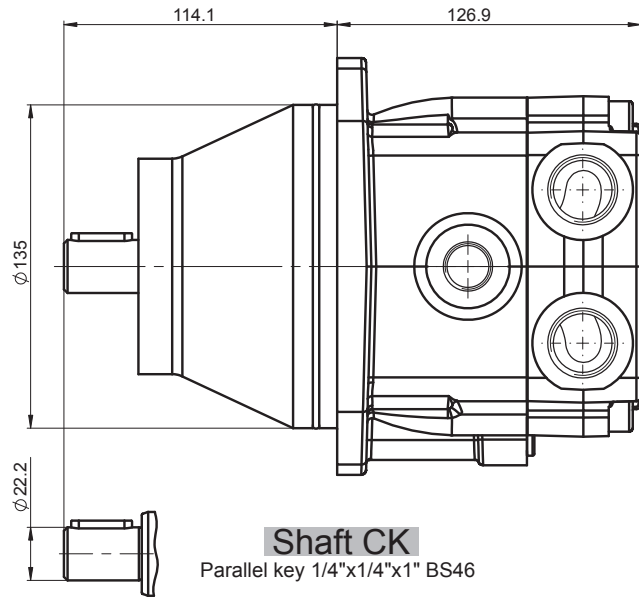

Shaft CK
Parallel key 1/4"x1/4"x1" BS46

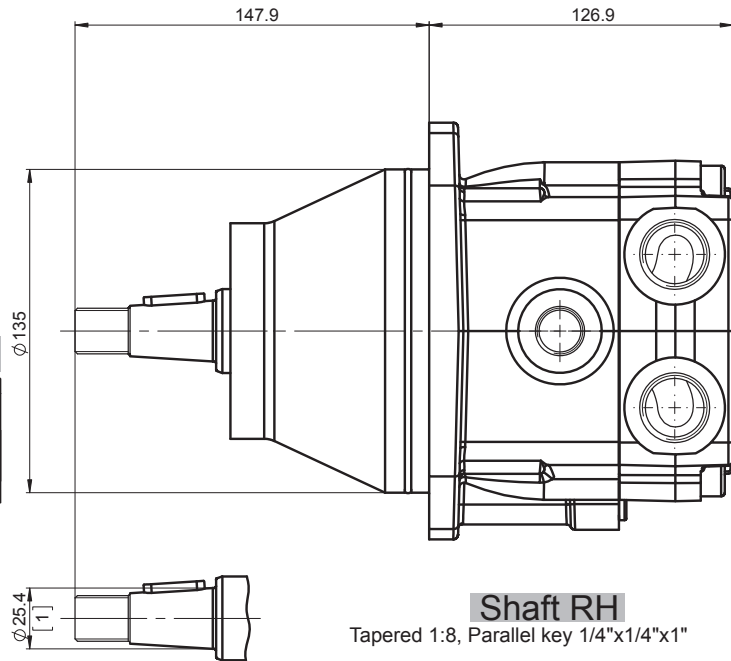

Shaft RH
Tapered 1:8, Parallel key 1/4"x1/4"x1"

Shaft Dimensions
See pages 14,15

PERMISSIBLE SHAFT LOAD

Permissible shaft load		Standard bearing	Improved bearing
max Axial	N[lb]	Fa=1000	Fa=2000
max Radial	N[lb]	Fr=350	Fr=3000

The calculated max values are based on the optimal direction of the forces Fr, Fa and optimal position of the shaft (see scheme below).

For more information, please, feel free to contact us.

BEST POSITION FOR APPLYING RADIAL LOAD

Optimal position for applying radial load depending on the direction of rotation

Reverse Rotation

Standard Rotation

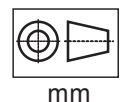
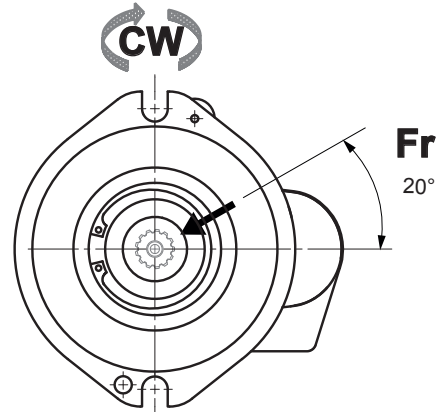
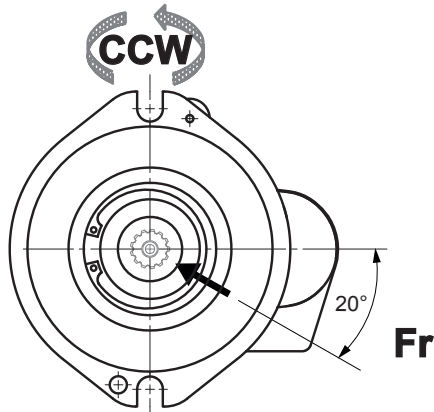

ORDERING CODE

	1	2	3	4	5	6	7	8	9	10	11	12	13	14	15	15	15
TMV				-											[]

- Pos.1 - Mounting Flange**
omit - Wheel flange, cartage - 2-Bolt flange
spigot diam. 135 mm - BC 155 mm
- Pos.2 - Port Type**
T - Twin side ports on one side, side control port
H - Twin side ports on one side, rear control port
E - Rear ports, rear control port
- Pos.3 - Max. Displacement Code*** (see table below)

Cross Reference Displacement Table

Pos.4 Min. Displacement cm ³ /n	Pos.3 Max. Displacement cm ³ /n				
	25	30	35	38	45
2	X	X	X	X	X
8	X	X	X	X	X
9	X	X	X	X	X
10	X	X	X	X	X
11	X	X	X	X	X
12	X	X	X	X	X
13	X	X	X	X	X
14	X	X	X	X	X
15	X	X	X	X	X
16	X	X	X	X	X
17	X	X	X	X	X
18	X	X	X	X	X
19	X	X	X	X	X
20	X	X	X	X	X
22		X	X	X	X
23		X	X	X	X
25		X	X	X	X
27			X	X	X
29			X	X	X
32				X	X

On Table are shown:
- Min./Max. Displacement Combinations
other combinations are possible

- Pos.4 - Min. Displacement Code*** (see table above)
- Pos.5 - Shaft Extensions****
PD - ø21,72 Spline SAE 13T 16/32 DP,
1/4-20 UNC-2B thread
PF - ø24.9 Spline SAE 15T 16/32 DP,
1/4-20UNC-2B thread
CK - ø22.2 Straight, M8-6H thread
Parallel key 1/4"x1/4"x1" BS46
RH - ø25.4 Tapered 1:8,
Parallel key 1/4"x1/4"x1", 3/4-16 UNF-2A

- Pos.6 - Improved radial load**
omit - standard bearing
N - Improved bearing

- Pos.7 - Port Size**
2 - 2xG3/4
3 - 2xM27x2
4 - 2x1_1/16 -12 UN

- Pos.8 - Seal, Corrosion Resistant Seal Surface**
omit - NBR seal type material
V - FKM seal type material

- Pos.9 - Integrated Valves**
See next page for information about valves
omit - None
PU - Purge valve
FLU - Flush valve
SAR - Single anti-cavitation and relief valve
SARF - Single anti-cavitation, relief and flush valve

- Pos.10 - Valves Port for Single Valves**
omit - None
A - Port A
B - Port B

- Pos.11 - Pressure Setting of Integrated Valves**
omit - None
x - For value - see next page

- Pos.12 - Flow Setting of Integrated Valves**
omit - None
Lx - For value - see next page

- Pos.13 - Special Features*****
omit - None
R2S - Speed Sensor Two Directional

- Pos.14 - Paint and Coating**
omit - No paint or coating
P - Painted
PC - Corrosion protected paint

If a painting option is required, the standard color is black-Alkyd-Styrenated Enamel, Black RAL 9005.
Other color by customer's request.

- Pos.15 - Design Series**
omit - Factory specified
* Other combination are available please ask on enquiry
** The permissible output torque for shafts must not be exceeded!
** Non painted feeding surface
*** Available on enquiry
We remain open to meet your special requirements upon request.

EXAMPLE

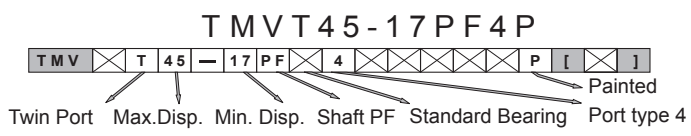

Valve Options

The overall dimensions of the motor with integrated valves could vary compared to the standard motors.

**Option PU
PURGE VALVE**

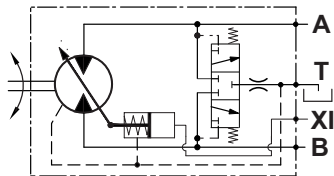

- Mainly used in open loop circuit;
- Used for cooling purpose or oil cleanliness requirements;
- Flow rate by **default (omit) - 3.5 ÷ 4.9 l/min.**
- For other options, please see Pos.12 of ordering code, considering the following possible values:

Pos.12

omit	L2	L6	L7.5
------	----	----	------

 → flow rate

EXAMPLE

TMVT45-17PF4PU

purge valve flow rate 4.2±0.7 l/min

TMVT45-17PF4PUL2

purge valve flow rate 2±2.5 l/min

TMVT45-17PF4PUL7.5

purge valve flow rate 7.5±1 l/min

TMVT45-17PF4PUL6

purge valve flow rate 6±0.8 l/min

**Option FLU
FLUSH VALVE**

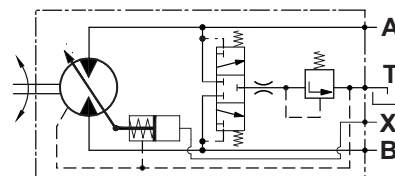

- Mainly used in close loop circuit;
- The valve is a combination between a purge valve and check valve;
- Flow rate by **default (omit) - 3.5 ÷ 4.9 l/min and cracking (opening) pressure 10.3 bar** with 15 bar feed pressure for close loop circuit.
- For other options, please see Pos.11 and Pos. 12 of ordering code, considering the following possible values:

Pos.11

omit	7
------	---

 → pressure

Pos.12

omit	L2	L6	L7.5
------	----	----	------

 → flow rate

EXAMPLE

TMVT45-17PF4FLU

flow rate 4.2±0.7 l/min,
crack pressure 10.3 bar

TMVT45-17PF4FLU7L7.5

flow rate 7.5±1 l/min,
crack pressure 7 bar

TMVT45-17PF4FLUL2

flow rate 2±2.5 l/min,
crack pressure 10.3 bar

Option SARA, SARB

Combined Anti-Cavitation and Relief Valve

- Anti-cavitation check valve is used for applications such as Fan drive control;
- Pressure relief valves prevent excessive pressures in the high pressure loop.

SARA

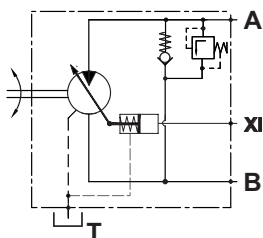

SARB

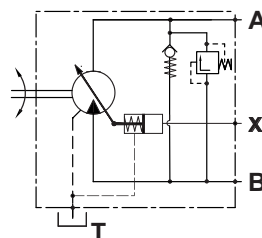

Please, consider the following possible values:

Pos.11

280	300	345
-----	-----	-----

 → pressure

EXAMPLE

TMVT45-17PF4SARA280

Single Anti-Cavitation and Relief Valve, relief valve setting 280 bar
The valve is placed on port A

TMVT45-17PF4SARB300

Single Anti-Cavitation and Relief Valve, relief valve setting 300 bar
The valve is placed on port B

Valve Options

The overall dimensions of the motor with integrated valves could vary compared to the standard motors.

Option SARFA, SARFB
Single Anti-Cavitation, Relief and Flush Valve

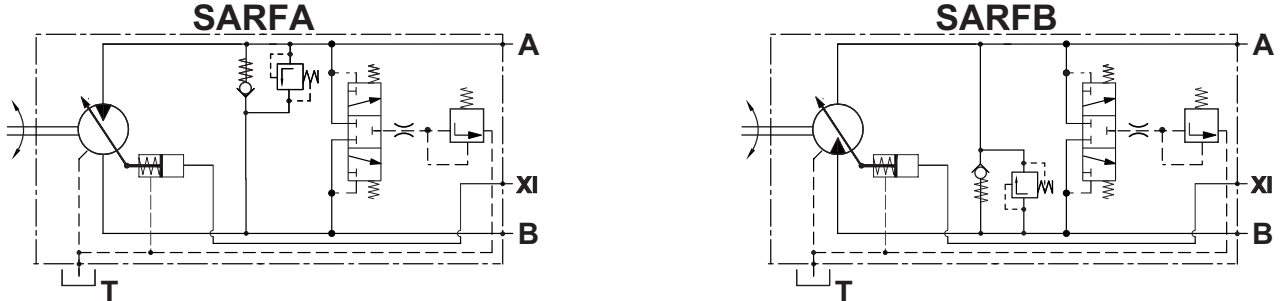

- Mainly used in close loop circuit;
- The valve is a combination between a dual anti-cavitation, relief and flush valve;
- Flush valve is used for cooling purpose or cleanliness requirements;
- Anti-Cavitation Check valve is used for applications such as Fan drive control;
- Pressure Relief Valves prevent excessive pressures in the high pressure loop;
- Please, consider the following possible values for pressure set of the relief valve:

Pos.11

280	300	345
-----	-----	-----

 → pressure

- Flow rate of flush valve by **default (omit)** - **3.5 ÷ 4.9 l/min and cracking pressure 10.3 bar** with 15 bar feed pressure for close loop circuit. The possible values are as follow:

Pos.12

omit	L2	L6	L7.5
------	----	----	------

 → flow rate

- Other values for **cracking** pressure are possible. Please see Pos.11. Example: For cracking pressure 7 bar the options are as follow:

Pos.11

280-7	300-7	345-7
-------	-------	-------

 Relief valve opening pressure Flush valve cracking pressure (charge pressure)

EXAMPLE

TMVT45 - 17PF4 SARFA 345
Single Anti-Cavitation, Relief and Flush Valve, relief valve setting 345 bar
flush valve cracking pressure 10.3 bar, flush valve flow rate 4.2±0.7 l/min
The valve is placed on port A

TMVT45 - 17PF4 SARFB 345-7
Single Anti-Cavitation, Relief and Flush Valve, relief valve setting 345 bar
flush valve cracking pressure 7 bar, flush valve flow rate is 4.2±0.7 l/min
The valve is placed on port B

TMVT45 - 17PF4 SARFA 280L2
Single Anti-Cavitation, Relief and Flush Valve, relief valve setting 280 bar
flush valve cracking pressure 10.3 bar, flush valve flow rate is 2±2.5 l/min
The valve is placed on port A

TMVT45 - 17PF4 SARFB 300-7L7.5
Single Anti-Cavitation, Relief and Flush Valve, relief valve setting 300 bar
flush valve cracking pressure 7 bar, flush valve flow rate 7.5±1 l/min
The valve is placed on port B

Shaft Types and Dimensions

PD

ϕ **21.72**, 1/4-20 UNC-2B thread
13T 16/32 DP splined ANSI B92.1-1996
Max. torque 200 Nm

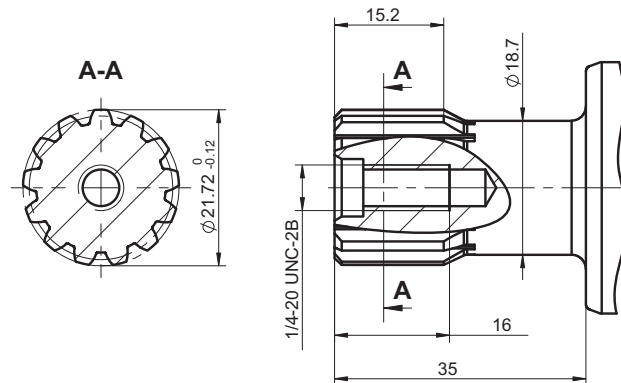

PF

ϕ **24.89**, 3/8-16 UNC-2B thread
15T 16/32 DP splined ANSI B92.1-1970
Max. torque 330 Nm

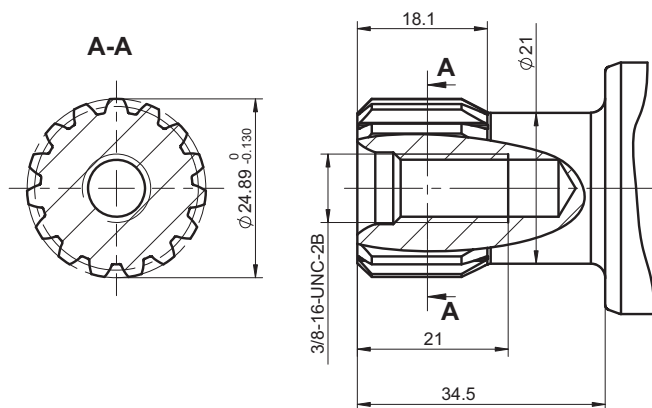

The required max. torque
must not be exceeded

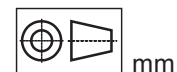

Shaft Types and Dimensions

CK

$\phi 22.2$ straight, M8-6H thread
Parallel key 1/4"x1/4"x1"BS46
Max. torque 180 Nm

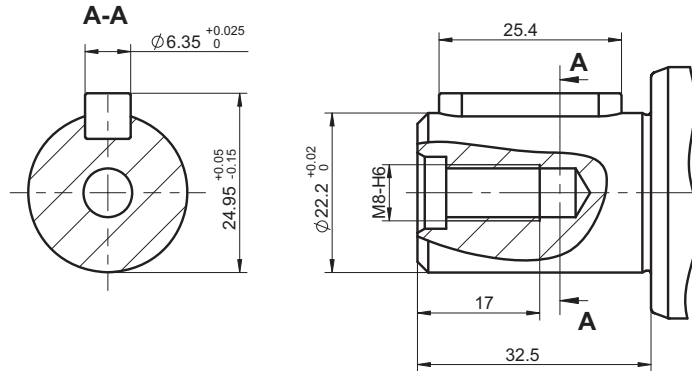

RH

$\phi 25.4$ Tapered 1:8,
Parallel key 1/4"x1/4"x1", 3/4-16 UNF-2A
Max. torque 300Nm

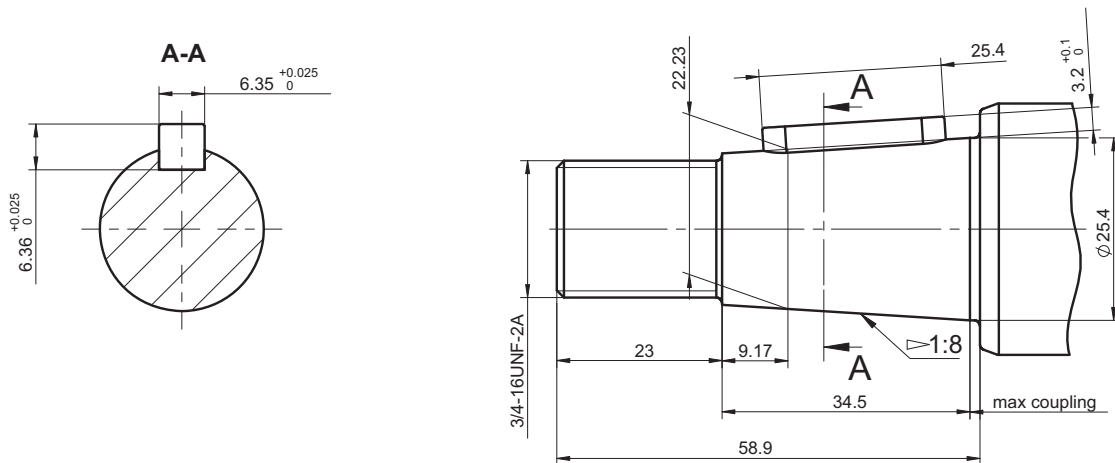

The required max. torque must not be exceeded

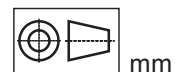

Speed Sensors

MOUNTING DIMENSIONS

TMV

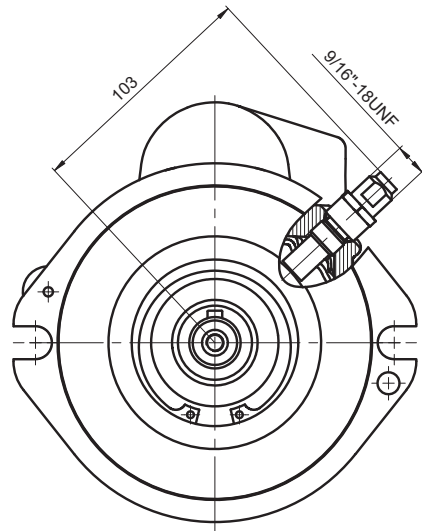
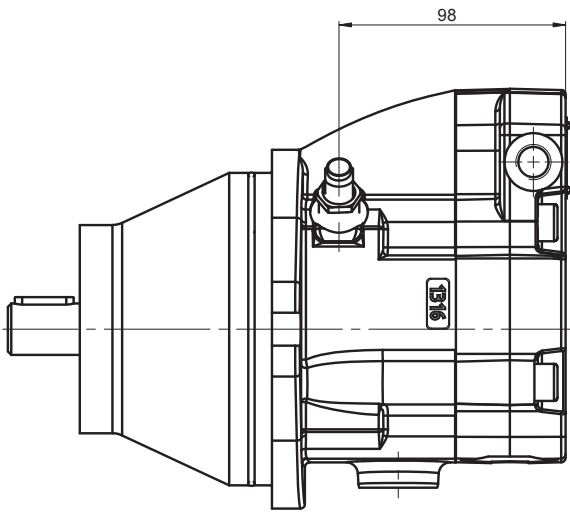

TECHNICAL DATA

Power supply	4.5 ... 30 VDC
Power consumption	< 15 mA
Pin connector	universal /PUSH-PULL/ 4P Delphi Connector DJ3042&-2.5-21
Output measurements	Speed, Direction
Output maximum current	100 mA
Resident output voltage	1.5 V for external current 100 mA 0.5 V without external load
Frequency range	0 ... 15 000 Hz
Protection	IP 67
Ambient Temperature	-40 ... + 100 °C
Humidity	0 ... 95% RH

OUTPUT PULSES

per revolution

Motor Type	TMV
Output Pulses	45

MOUNTING

Maximal mounting clearance is 1.5 mm
Maximal mounting torque 13 Nm
Sensor orientation should be kept according instruction

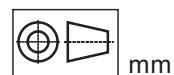

Speed Sensors

OUTPUT DIAGRAMS

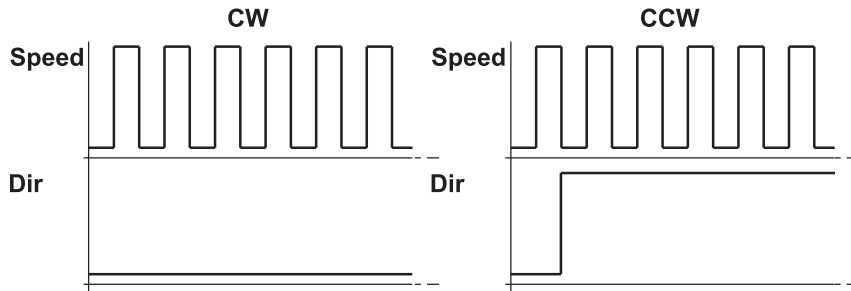

PIN CONNECTOR

4 pin Delphi Connector

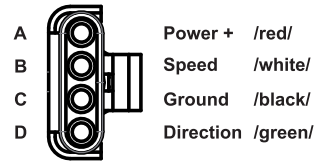

WIRING DIAGRAMS

Sensor could be in use for both type of connections - PNP or NPN

PNP

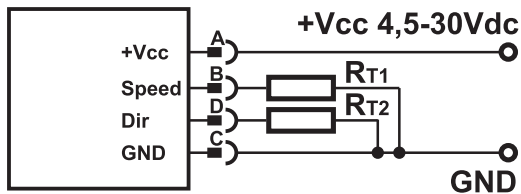

NPN

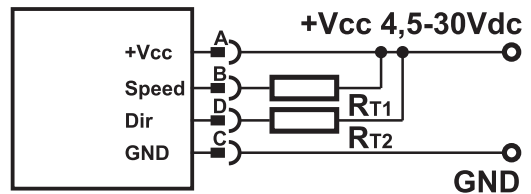

SENSOR OVERALL DIMENSIONS

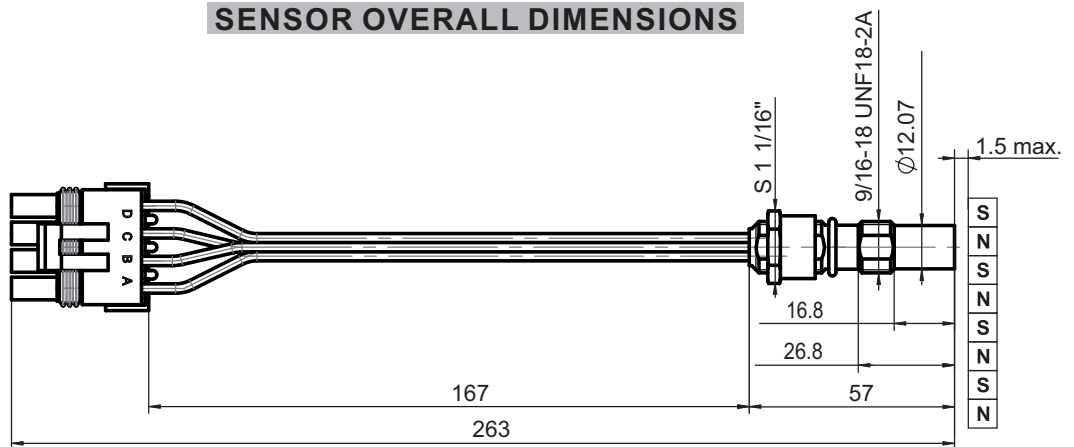

Fluid Viscosity Limits

In order to obtain optimum efficiency and service life, we recommend to select the operating viscosity (at operating temperature) within the range shown on diagram below.

Kinematic viscosity

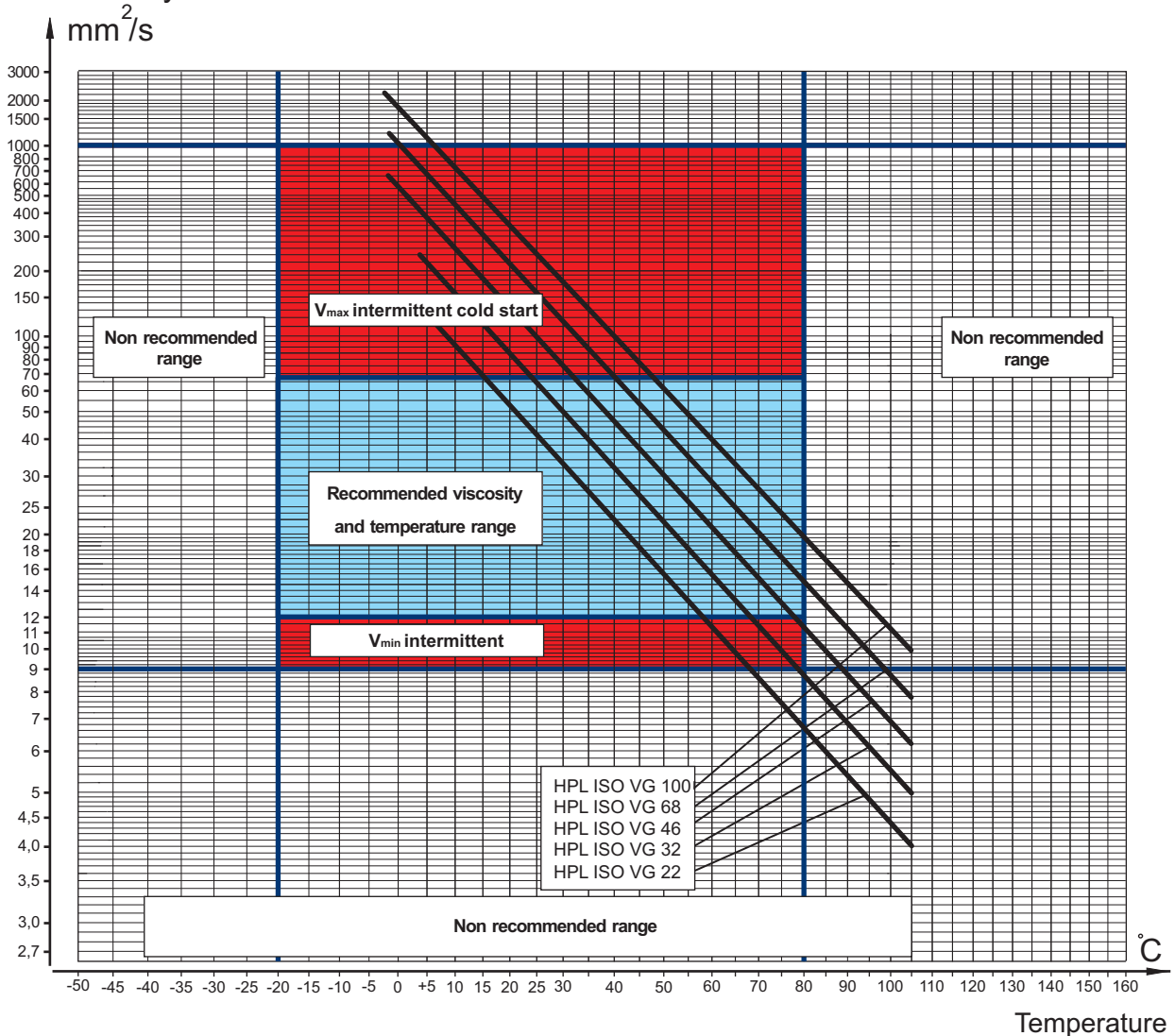

The above - shown viscosity characteristics are for reference only. Please, check the actual viscosity with the manufacturer of the fluid.

Basic Formulas

The motor size, pressure and flow required for a specific application can be calculated using the formulas below.

	Metric System		Inch System
Efficiency	$\eta_t = \eta_{mh} \cdot \eta_v$ $\eta_{mh} = \frac{\eta_t}{\eta_v}$ $\eta_v = \frac{\eta_t}{\eta_{mh}}$		$\eta_t = \eta_{mh} \cdot \eta_v$ $\eta_{mh} = \frac{\eta_t}{\eta_v}$ $\eta_v = \frac{\eta_t}{\eta_{mh}}$
Input flow (for Motor)	$Q = \frac{Vg \cdot n}{1000 \cdot \eta_v}$ [l/min]		$Q = \frac{Vg \cdot n}{231 \cdot \eta_v}$ [GPM]
Output torque (for Motor)	$M = \frac{Vg \cdot \Delta p \cdot \eta_{mh}}{62.8}$ [Nm]		$M = \frac{Vg \cdot \Delta p \cdot \eta_{mh}}{2 \cdot \pi}$ [lb-in]
Output power (for Motor)	$P = \frac{M \cdot n}{9550} = \frac{Q \cdot \Delta p \cdot \eta_t}{60}$ [kW]		$P = \frac{Vg \cdot n \cdot \Delta p \cdot \eta_t}{396000}$ [hp]
Speed (for Motor)	$n = \frac{Q \cdot 1000 \cdot \eta_v}{Vg}$ [min ⁻¹]		$n = \frac{Q \cdot 231 \cdot \eta_v}{Vg}$ [min ⁻¹]
Output flow (for pump)	$Q = \frac{Vg \cdot n \cdot \eta_v}{1000}$ [l/min]		

Application Formulas

Motor speed: n [min⁻¹]

$$n = \frac{2,65 \cdot v_{km} \cdot i}{R_m} \qquad n = \frac{168 \cdot v_{mi} \cdot i}{R_{in}}$$

- v_{km} - vehicle speed [km/h]
- v_{mi} - vehicle speed [mil/h]
- R_m - wheel rolling radius [m]
- R_{in} - wheel rolling radius [in]
- i - gear ratio between motor and wheels.
- If no gearbox, use $i=1$.

Radial motor loading: P_{rad}, N [lbs]

When the motor is used for motion with a ring or gear mounted directly on the motor shaft, the total radial load of the motor shaft **P_{rad}** is the sum of the motion force and the weight force acting on ring.

- G_w** - Weight held by the shaft
- P_{rad}** - Total radial load of the motor shaft
- M/R** - Motion force

$$P_{rad} = \sqrt{G_w^2 + \left(\frac{M}{R}\right)^2}$$

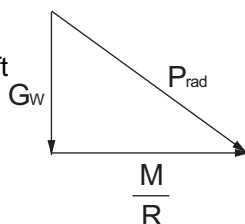

Total tractive effort: TE, N [lbs]

Total tractive effort **TE** is the total effort necessary for vehicle motion i.e. the sum of the calculated forces increased by 10 % because of air resistance.

$$TE = 1,1 \cdot (RR + GR + FA + DP)$$

- RR** - force required to overcome the rolling resistance
- GR** - force required to slope upwards
- FA** - force required to accelerate (acceleration force)
- DP** - additional tractive effort (trailer)

Motor Torque moment: M, Nm [lb-in]

Necessary torque for the hydraulic motor:

$$M = \frac{TE \cdot R_m [R_{in}]}{N \cdot I \cdot \eta_M}$$

- I** - motor numbers
- η_M - mechanical gearbox efficiency (if it is available)

Depending on the results of the load calculations, the most appropriate type of motor from the catalogue is selected.

As HANSA-TMP has a very extensive range of products and some products have a variety of applications, the information supplied may often only apply to specific situations.

If the catalogue does not supply all the information required, please contact HANSA-TMP.

In order to provide a comprehensive reply to queries we may require specific data regarding the proposed application.

Whilst every reasonable endeavour has been made to ensure accuracy, this publication cannot be considered to represent part of any contract, whether expressed or implied.

The data in this catalogue refer to the standard product. The policy of HANSA-TMP consists of a continuous improvement of its products. It reserves the right to change the specifications of the different products whenever necessary and without giving prior information.



HYDRAULIC COMPONENTS
HYDROSTATIC TRANSMISSIONS
GEARBOXES - ACCESSORIES

Via M. L. King, 6 - **41122 MODENA (ITALY)**

Tel: +39 059 415 711

Fax: +39 059 415 729 / 059 415 730

INTERNET: <http://www.hansatmp.it>

E-MAIL: hansatmp@hansatmp.it