

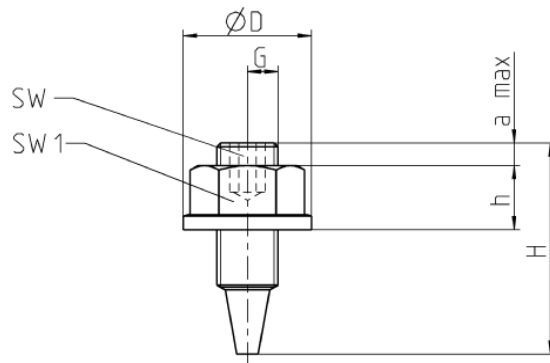

Symbol:

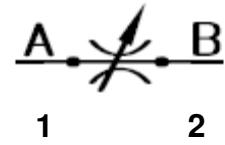

- Betriebsdruck: 400 bar
- mit Schutzkappe

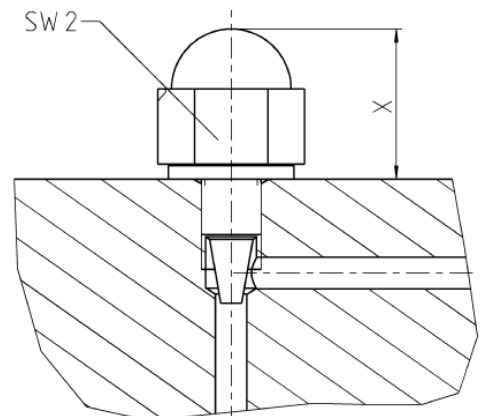
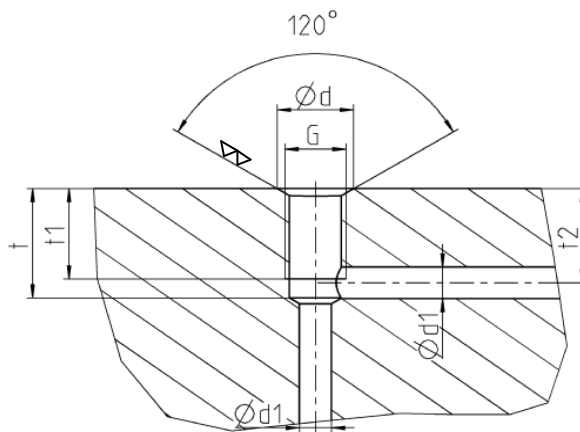

Volumenstrom [l/min]	G	D	H	a max	H	SW	SW 1	SW2	D	D1	T	T1	T2	x
16	M10 x 1	21	36	8	9	5	17	21	12,5 (+0,3)	5,2	18,5	15,5	16	25