

ENGINEERING  
TOMORROW

*Danfoss*

Technical Catalog

## Vickers by Danfoss **PVM Variable Displacement Piston Pumps**

Up to 315 bar  
18-141cc  
(1.1-8.6in<sup>3</sup>)  
Variable Speed Drive Ready

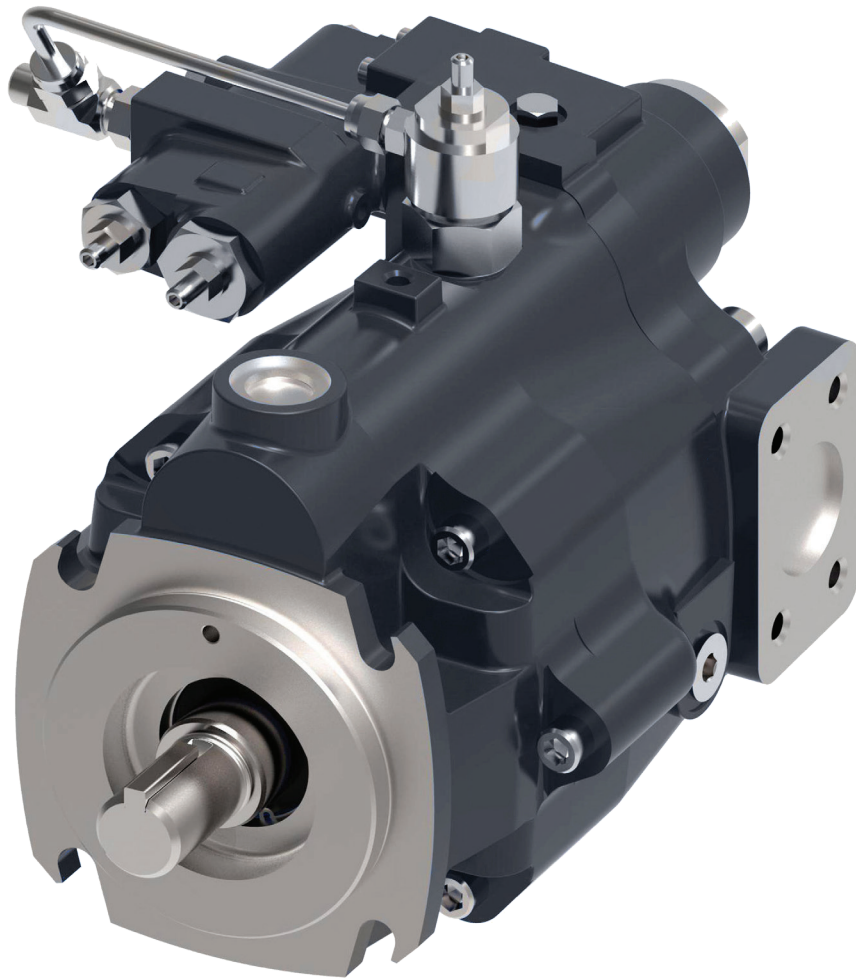

**VICKERS**  
by Danfoss

BC436067900311en-000103

# Table of Contents

## M Series Variable Displacement Piston Pumps

Introduction .....	3
Hydraulic System Design Calculations .....	4
Model Code Selection .....	5
Model Code Options .....	6
Specifications and Performance .....	8
Control Options .....	11
Performance – Industrial	
PVM018 .....	15
PVM020 .....	20
PVM045 .....	25
PVM050 .....	30
PVM057 .....	35
PVM063 .....	40
PVM074 .....	45
PVM081 .....	50
PVM098 .....	55
PVM106 .....	60
PVM131 .....	65
PVM141 .....	70
Dimensions	
PVM018/020 .....	75
PVM045/050 .....	82
PVM057/063 .....	89
PVM074/081 .....	94
PVM098/106 .....	98
PVM131/141 .....	102
Mounting Flange Options .....	107
Shaft Options .....	108
Input Shaft Selection Data .....	111
Port Options .....	112
Operating Requirements and Recommendations .....	114
Installation and Start-up .....	115

# Introduction

Danfoss M Series pumps are open circuit, axial piston designs. A variety of control options allows the pumps to perform most efficiently in a specific application. Efficiency of the pump controls allows down-sizing of system cooling needs, saving up front cost in the machine. Alternatively, cooling capacity could be kept the same and the flow capability of the system increased, thus improving performance and customer satisfaction.

The M Series also contains a strong proven rotating group allowing the pumps to handle pressures to 315 bar (4568 psi) continuous with less maintenance cost. High-load bearings and a stiff drive shaft help provide very long life at rated industrial conditions, reducing operating costs and extending operating life.

M Series pumps feature a saddle-type yoke with steel-backed polymer bearings. The stiff yoke reduces deflection and allows even loading of bearings, improving life. A single control piston reduces loading on the yoke, resulting in reduced pump size which allows installation in tighter locations.

M Series pumps operate at a level of quietness that exceeds the requirements of today's demanding work conditions. The pumps feature a unique three-piece envelope (flange, housing and valve block) specifically created for low fluid-borne and structure-borne noise levels. Another pump feature - a bimetal timing plate - improves pump filling characteristics which, in turn, reduce fluid-borne noise and extend pump life.

M Series pumps reduce, or in some cases remove, the need for damping barriers between the noise source and the operator. This saves money on the installed cost of the system while improving customer comfort.

An adjustable maximum stop provides a means of tuning flow to your system, while gauge ports allow monitoring of inlet and outlet conditions. These standard features reduce system complexity and cost.

Mounting flanges are offered in SAE and ISO configurations, and ports are offered in SAE ISO,



and BSPP in both tube and flange versions. This provides a wide variety of installation opportunities for global machine design.

Side- or end-ported models are available to facilitate plumbing and help fit the pump to your machine space needs. Multiple drain ports allow many mounting orientations, reducing installed costs.

M Series pumps are capable of operating with many types of hydraulic fluids used in industrial systems. High-water-content and phosphate ester fluids can be accommodated, in addition to the typical petroleum based and synthetic fluids.

## Typical Applications

- Mining machinery
- Injection molding machines
- Metal forming machines
- Oil and Gas Equipment
- Conveyor lines
- Primary metals
- Metal cutting equipment

## Features and Benefits

- Bell shaped housing contains fluid borne sound and reduces operator fatigue
- Standard adjustable maximum volume screw and gage ports give the ultimate in flexibility to the engineer or service technician
- High overall efficiency reduces operating costs
- Robust shaft bearings extends operating life and lowers maintenance costs
- Multiple port type and locations aid in flexibility of machine design
- Very low pressure ripple reduces shock in the system resulting in fewer leaks

# Hydraulic System Design Calculations

## Basic Formulas

### Output Flow (Q)

$$\text{lpm} = \frac{\text{cm}^3/\text{r} \times \text{rpm}}{1000} \quad \text{gpm} = \frac{\text{in}^3/\text{r} \times \text{rpm}}{231}$$

### Input Power (P)

$$\text{kW} = \frac{\text{l/min} \times \text{bar}}{600} \quad \text{hp} = \frac{\text{gpm} \times \text{psi}}{1714}$$

### Shaft Torque (M)

$$\text{N-m} = \frac{\text{bar} \times \text{cm}^3/\text{r}}{62.8} \quad \text{lb-in} = \frac{\text{psi} \times \text{in}^3/\text{r}}{6.28}$$

### Shaft Speed (n)

$$\text{rpm} = \frac{1000 \times \text{l/min}}{\text{cm}^3/\text{r}} \quad \text{RPM} = \frac{231 \times \text{gpm}}{\text{in}^3/\text{r}}$$

### Output Power (P)

$$\text{kW} = \frac{\text{N-m} \times \text{RPM}}{9549} \quad \text{hp} = \frac{\text{lb-in} \times \text{rpm}}{63,025}$$

### Volumetric Displacement

$$\text{cm}^3/\text{r} = \text{in}^3/\text{r} = \frac{\text{lpm} \times 1000}{\text{rpm}} \quad \frac{\text{gpm} \times 231}{\text{rpm}}$$

## Basic Formulas

bar = 10 Newtons/cm<sup>2</sup>

gpm = gallons per minute

hp = horsepower

lb-in = pound inch

lb-ft = pound feet

kW = kilowatt

kgf = kilograms force

l/min = liters per minute

N-m = Newton meters

psi = pounds per square inch rpm = revolutions per minute

## Efficiencies

$$\text{Volumetric } N_v = \frac{\text{gpm actual}}{\text{gpm theoretical}}$$

$$\text{Mechanical } N_m = \frac{\text{lb-in actual}}{\text{lb-in theoretical}}$$

$$\text{Total } N_t = N_v \times N_m$$

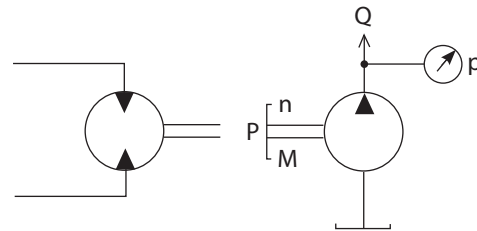

## Commonly Used Conversions

To Convert	Into	Multiply by
bar	psi	14.5
cm <sup>3</sup>	in <sup>3</sup>	0.06102
°C	°F	(°C x 1.8) + 32
gallons (US)	liters	3.785
kg	lbs	2.205
kgf/cm <sup>2</sup>	psi	14.2
kW	hp	1.341
liters	US Gallons	0.2642
mm	inches	0.03937
N-m	lb-in	8.85
N-m	lb-ft	0.7375
°F	°C	(°F-32)/1.8
hp	kW	0.7457
inch	mm	2.54
in <sup>3</sup>	cm <sup>3</sup>	16.39
lb-in	N-m	0.113
lb-ft	N-m	1.356
lbs	kg	0.4535
psi	bar	0.06896
psi	kgf/cm <sup>2</sup>	.070307

Note: Performance charts can be found on subsequent pages.

# Model Code Selection

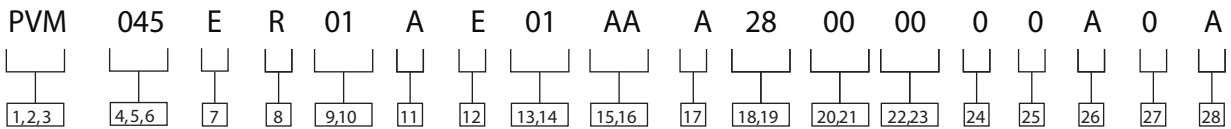

## 1,2,3 Product Series

PVM – M Series Variable Piston Pump

## 4,5,6 Displacement

Twelve displacements available 230 bar and 315 bar continuous ratings  
See page 6

## 7 Valve Plate

E - Quiet version, optimized for 1000-1800 rpm

M - Higher speed version. ref speed performance data for individual displacements

## 8 Input Rotation

R – Clockwise (Right hand)  
L<sup>1</sup> – Counter-clockwise (Lefthand)

See page 6

## 9,10 Input Shaft

Standard SAE and ISO splined versions (Other configurations optional)

## 11 Mounting Flange

Thirteen options in SAE and ISO mounts  
See page 6

## 12 Main Port Location

E<sup>2</sup> – End Ported  
S<sup>4</sup> – Side Ported

## 13,14 Main Port Type

SAE & ISO tube ports and 4-bolt flange (Other configurations optional)  
See page 7

## 15,16 Pump Special Features

00 – None  
AA – Adjustable Maximum Displacement Stop and single shaft (standard)  
AB – Double Shaft Seal, Two Way

## 17 Control

0 – None  
A – Pressure Compensator  
B – Pressure and Flow Compensator with Bleed Orifice  
C – Pressure and Flow Compensator with Plugged Orifice  
E – Industrial/Remote (57cc through 141 cc only)

L - Power Control with Load Sense and Pressure compensator with plugged orifice.

W - Remote pressure control (018-050 size only) with - 4 SAE O-ring port, left side

## 18,19 Pressure Compensator Setting

00 – None  
07 – 70 bar (Adjustable between 40 bar and 130 bar)  
23 – 230 bar (Adjustable between 130 bar and 320 bar)  
28 – 280 bar (Adjustable between 130 bar and 320 bar)

## 20,21 Flow Compensator Setting

00 – None  
10 – Standard for W control  
11 – 11 bar setting  
20 – 20-20 bar setting  
24 – 24-24 bar setting

## 22,23 Power control Torque Limiter Setting

00 – None  
50-50% of rated torque\*  
(Adjustable from 20-90% of rated torque,\*for any other values specify % of rated torque )

## 24 Compensator Special Features

0 – None

## 25 Auxiliary Mounting Pad

0<sup>3</sup> – None  
(Auxiliary mounting available on all frame sizes)  
See page 7

## 26 Paint

0 – No Paint  
A – Standard Blue Paint

## 27 Customer Identification

0 – None (Contact Eaton for Options)

## 28 Design Code

A – A (Initial Release)

1 Not available on 074, 081, 098 and 106 End Port

2 Not available on 074, 081, 098 and 106 displacement with CCW rotation ("L" in position 8)

3 Through drive not available on the CCW rotation ("L" in position 8) on 074, 081,098 and displacement

4 Not available on 018

# Model Code Options

## 4,5,6 Maximum Geometric Displacement

Displacement Code	018	020	045	050	057	063	074	081	098	106	131	141
cm <sup>3</sup> /r	18,0	21,1	45,1	50,0	57,4	63,1	73,7	81,0	98,3	106,5	131,1	141,0
in <sup>3</sup> /r	1.1	1.29	2.75	3.05	3.50	3.85	4.50	4.94	6.00	6.50	8.00	8.60

## 9,10 Shaft-End Type at Electric Motor End

Description	Shaft Code					
	PVM018/020	PVM045/050	PVM057/063	PVM074/081	PVM098/106	PVM131/141
SAE, SAE A, Straight Keyed	01	-	-	-	-	-
SAE, SAE 19-1, Straight Keyed	02	-	-	-	-	-
SAE, SAE A, 9T Spline	03	-	-	-	-	-
SAE, SAE A, 11T Spline	04	-	-	-	-	-
SAE, SAE B, Straight Keyed	05	05	-	-	-	-
SAE, SAE B-B, Straight Keyed	06	06	06	-	-	-
SAE, SAE B, 13T Spline	07	07	07	-	-	-
SAE, SAE B-B, 15T Spline	08	08	08	-	-	-
SAE, SAE C, Straight Keyed	-	-	09	09	09	09
SAE, SAE C-C, Straight Keyed	-	-	-	10	10	10
SAE, SAE C, 14T Spline	-	-	11	11	11	11
SAE, SAE C-C, 17T Spline	-	-	-	12	12	12
SAE, SAE D, Straight Keyed	-	-	-	-	-	13
SAE, SAE D, 13T Spline	-	-	-	-	-	14
ISO E20N, Straight Keyed	15	-	-	-	-	-
ISO E25N, Straight Keyed, Short Spigot	16	-	-	-	-	-
ISO E25N, Straight Keyed	17	17	17	-	-	-
ISO E32N, Straight Keyed, Short Spigot	-	-	18	18	18	18
ISO E40N, Straight Keyed, Short Spigot	-	-	-	19	19	19

## 11 Mounting Flange Specifications

Code	Description	PVM018/020	PVM045/050	PVM057/063	PVM074/081	PVM098/106	PVM131/141
A	SAE A, 2-bolt	●	○	○	○	○	○
B	ISO 80A2HW	●	○	○	○	○	○
C	SAE B, 2-bolt	●	●	●	○	○	○
D	ISO 100A2HW	●	●	●	○	○	○
E	SAE C, 2-bolt	○	○	●	●	●	●
F	ISO 125-A2HW	○	○	●	●	●	●
G	SAE C, 4-bolt	○	○	●	●	●	●
H	ISO 125B4HW	○	○	●	●	●	●
J	SAE D, 4-bolt	○	○	○	○	○	●
K	ISO 160B4HW	○	○	○	○	○	●

● = Available

○ = Not Available

# Model Code Options

## 13,14 Main Port Options

Code	Description	Inlet	PVM018/020	PVM045/050	PVM057/063	PVM074/081	PVM098/106	PVM131/141
01	SAE J1926 Tube Ports	Inlet	-20	-24	-24 (End ports only)	-	-	-
		Outlet	-12	-16	-16 (End ports only)	-	-	-
02	SAE J518 Flange Ports	Inlet	1.25 inch	2.0 inch	2.0 inch	2.0 inch	2.5 inch	2.5 inch
		Outlet	0.75 inch	1.0 inch	1.0 inch	1.0 inch	1.0 inch	1.25 inch*
03	ISO 6149-1 Tube Ports	Inlet	M42	M48	M48 (End ports only)	-	-	-
		Outlet	M27	M33	M33 (End ports only)	-	-	-
04	ISO 6162 Flange Ports	Inlet	32mm	51mm	51mm	51mm	64mm	64mm
		Outlet	19mm	25mm	25mm	25mm	25mm	32mm*
05	British Standard Parallel Pipe – Tube Ports	Inlet	G 1-1/4	G 1-1/2	-	-	-	-
		Outlet	G 3/4	G 1	-	-	-	-

\*SAE Code 62, high pressure series, or ISO 400 bar. Other flange ports are SAE Code 61, standard pressure series, or ISO 25-350 bar

## 25 Thru-Drive Options

Code	Description	PVM018/020	PVM045/050	PVM057/063	PVM074/081*	PVM098/106	PVM131/141
O	Single pump, non-thru-drive	●	●	●	●	●	●
A	SAE A, 2-bolt, 9T spline	●	●	●	●	●	●
B	SAE A, 2-bolt, 11T spline	●	●	○	●	●	●
C	SAE B, 2-1/4-bolt, 13T spline	○	●	●	●	●	●
D	SAE B-B, 2-1/4-bolt, 15T spline	○	●	●	●	●	●
E	SAE C, 2-1/4-bolt, 14T spline	○	○	●	●	●	●
F	SAE C-C, 2-1/4-bolt, 17T spline	○	○	○	●	●	●
G	ISO 80-A2HW, 9T SAE spline	●	●	●	●	●	●
H	ISO 80-A2HW, 11T SAE spline	●	●	○	●	●	●
J	ISO 100-A2/B4HW, 13T SAE spline	○	●	●	●	●	●
K	ISO 100-A2/B4HW, 15T SAE spline	○	○	●	●	●	●
L	ISO 125-A2/B4HW, 14T SAE spline	○	○	●	●	●	●
M	ISO 125-A2/B4HW, 17T SAE spline	○	○	○	●	●	●

● = Available

○ = Not Available

\* Not available on the 074/081 LH

# Specifications and Performance

Quiet version, optimized for 1000-1800 rpm (E)

Displacement, Pressure and Flow Ratings At 50°C (120°F), SAE 10W oil, 1 bar absolute (0 psig) inlet

Model Series	Maximum Geometric Displacement cm <sup>3</sup> /r (in <sup>3</sup> /r)	Maximum Pressure bar (psi)		Maximum Flow at 280 bar (4000 psi)* l/min (USgpm) – Average measured flow rate			
		Nominal	Peak**	@1800	@1500	@1200	@1000
				r/min	r/min	r/min	r/min
PVM018	18 (1.1)	315 (4568)	350 (5000)	31 (8.2)	26 (7)	21 (5.5)	17 (4.5)
PVM020	21,1 (1.29)	230 (3300)	280 (4000)	35 (9)	29 (8)	23 (6)	19 (5)
PVM045	45,1 (2.75)	315 (4568)	350 (5000)	76 (20)	65 (17)	49 (13)	42 (11)
PVM050	50,0 (3.05)	230 (3300)	280 (4000)	87 (23)	75 (20)	62 (16)	49 (13)
PVM057	57,4 (3.50)	315 (4568)	350 (5000)	102 (27)	85 (22.4)	66 (17.4)	54 (14.3)
PVM063	63,1 (3.85)	230 (3300)	280 (4000)	111 (29)	93 (24)	74 (19)	60 (16)
PVM074	73,7 (4.50)	315 (4568)	350 (5000)	127 (33.5)	106 (28)	86 (22.7)	70 (18.5)
PVM081	81,0 (4.94)	230 (3300)	280 (4000)	139 (37)	116 (31)	93 (25)	76 (20)
PVM098	98,3 (6.00)	315 (4568)	350 (5000)	170 (45)	141 (37)	112 (29.6)	92 (24.3)
PVM106	106,5 (6.50)	230 (3300)	280 (4000)	187 (49)	155 (41)	123 (32)	102 (27)
PVM131	131,1 (8.00)	315 (4568)	350 (5000)	215 (57)	178 (47)	141 (37)	118 (31)
PVM141	141,0 (8.60)	230 (3300)	280 (4000)	238 (63)	199 (53)	158 (42)	131 (35)

\*\*Momentary system pressure spikes only.

Speed, Input Power and Torque Ratings At 50°C (120°F), SAE 10W oil, 1 bar absolute (0 psig) inlet

Model Series	Maximum Operating Speed r/min	Maximum Input Power at 280 bar (4000 psi) kw (hp)*@88% M.E.				Maximum Torque at 280 bar (4000 psi)* Nm (lb-ft)	Approximate Weight kg (lb)
		@1800 r/min	@1500 r/min	@1200 r/min	@ 1000 r/min		
		PVM018	1800	16 (22)	13 (18)		
PVM020	1800	14 (18)	11 (15)	9 (12)	8 (10)	73 (54)	15 (33)
PVM045	1800	41 (55)	34 (46)	27 (37)	23 (31)	221 (163)	24 (52)
PVM050	1800	35 (47)	30 (40)	28 (38)	23 (31)	190 (140)	24 (52)
PVM057	1800	52 (70)	44 (59)	36 (49)	29 (39)	272 (201)	36 (79)
PVM063	1800	42 (57)	36 (48)	29 (39)	24 (32)	228 (168)	36 (79)
PVM074	1800	63 (84)	52 (70)	42 (56)	35 (47)	334 (246)	45 (99)
PVM081	1800	56 (75)	46 (62)	35 (47)	28 (37)	286 (211)	45 (99)
PVM098	1800	88 (118)	72 (97)	58 (78)	48 (64)	464 (342)	55 (121)
PVM106	1800	72 (97)	60 (80)	48 (64)	40 (54)	383 (282)	55 (121)
PVM131	1800	113 (152)	94 (126)	75 (101)	63 (85)	596 (440)	66 (145)
PVM141	1800	94 (126)	79 (106)	63 (85)	53 (71)	497 (367)	66 (145)

Standard Response Times\*

Model Series	On Stroke (msec)	Off Stroke (msec)
PVM018	30	25
PVM020	39	26
PVM045	140	40
PVM050	140	40
PVM057	65	20
PVM063	85	20

\* 3300 psi on overbore pumps

Standard Response Times\*

Model Series	On Stroke (msec)	Off Stroke (msec)
PVM074	85	30
PVM081	85	30
PVM098	65	25
PVM106	72	29
PVM131	135	30
PVM141	100	30

\*Values with pressure compensator control.



# Specifications and Performance

Higher speed version (M)

Displacement, Pressure and Flow Ratings At 93°C (200°F), SAE 10W oil, 1 bar absolute (0 psig) inlet

Model Series	Geometric Displacement cm <sup>3</sup> /r (in <sup>3</sup> /r)	Maximum Pressure bar (psi)		Maximum Flow at 280 bar (4000 psi)	
		Nominal	Peak**	Flange Ports l/min (USgpm) @ 1 bar inlet	Tube Ports l/min (USgpm) @ 1 bar inlet
PVM018	18,0 (1.10)	315 (4568)	350 (5000)	46 (12) @ 2800 r/min	46 (12) @ 2800 r/min
PVM020	20,1 (1.22)	230 (3300)	280 (4000)	53 (14) @ 2800 r/min	53 (14) @ 2800 r/min
PVM045	45,1 (2.75)	315 (4568)	350 (5000)	115 (30) @ 2600 r/min	106 (28) @ 2400 r/min
PVM050	50,0 (3.05)	230 (3300)	280 (4000)	125 (33) @ 2600 r/min	116 (31) @ 2400 r/min
PVM057	57,4 (3.50)	315 (4568)	350 (5000)	140 (37) @ 2500 r/min	128 (34) @ 2300 r/min
PVM063	63,1 (3.85)	230 (3300)	280 (4000)	150 (40) @ 2500 r/min	140 (37) @ 2400 r/min
PVM074	73,7 (4.50)	315 (4568)	350 (5000)	163 (43) @ 2400 r/min	–
PVM081	81,0 (4.94)	230 (3300)	280 (4000)	181 (48) @ 2400 r/min	–
PVM098	98,3 (6.00)	315 (4568)	350 (5000)	200 (53) @ 2200 r/min	–
PVM106	106,5 (6.50)	230 (3300)	280 (4000)	222 (59) @ 2200 r/min	–
PVM131	131,1 (8.00)	315 (4568)	350 (5000)	233 (62) @ 2000 r/min	–
PVM141	141,0 (8.60)	230 (3300)	280 (4000)	258 (68) @ 2000 r/min	–

\*\*Less than 0.5 second.

## Standard Response Times\*

Model Series	On Stroke (msec)	Off Stroke (msec)
PVM018	50	20
PVM020	57	22
PVM045	140	40
PVM050	140	23
PVM057	65	20
PVM063	94	20

## Standard Response Times\*

Model Series	On Stroke (msec)	Off Stroke (msec)
PVM074	95	30
PVM081	135	30
PVM098	85	24
PVM106	90	25
PVM131	100	30
PVM141	128	28

\*Values with pressure compensator control.

# Specifications and Performance

Higher speed version (M)

Speed, Input Power and Torque Ratings At 93°C (200°F), SAE 10W oil, 1 bar absolute (0 psig) inlet

Approximate Model Series	Operating Speed and Pressure r/min			Max. Input Power at Max. Speed and 280 bar (4000 psi) kW (hp)	Max. Torque at 280 bar (4000 psi) Nm (lb-ft)	Weight (dry) kg (lbs)
	1 bar Inlet Flange Ports	0,85 bar Inlet Tube Ports	0,85 bar Inlet Flange Ports			
PVM018	2800 r/min			24 (32)	82 (60)	15 (33)
		2800 r/min		24 (32)		
			2600 r/min	22 (30)		
PVM020	2800 r/min			21 (28)	72 (53)	15 (33)
		2800 r/min		21 (28)		
			2600 r/min	20 (27)		
PVM045	2600 r/min			56 (75)	198 (46)	24 (52)
		2400 r/min		53 (71)		
			2200 r/min	48 (64)		
PVM050	2600 r/min			51 (68)	204 (150)	24 (52)
		2400 r/min		48 (64)		
			2200 r/min	44 (59)		
PVM057	2500 r/min			68 (91)	262 (193)	36 (79)
		2300 r/min		62 (83)		
			2100 r/min	56 (75)		
PVM063	2500 r/min			59 (79)	225 (166)	36 (79)
		2400 r/min		57 (76)		
			2200 r/min	52 (69)		
PVM074	2400 r/min			84 (113)	334 (246)	45 (99)
			1900 r/min	69 (93)		
				69 (93)		
PVM081	2400 r/min			69 (93)	276 (204)	45 (99)
			1900 r/min	55 (74)		
				105 (141)		
PVM098	2200 r/min			86 (115)	457 (337)	55 (121)
			1800 r/min	87 (117)		
				70 (94)		
PVM106	2200 r/min			87 (117)	377 (278)	55 (121)
			1800 r/min	122 (164)		
				98 (131)		
PVM131	2000 r/min			122 (164)	581 (429)	66 (145)
			1600 r/min	102 (137)		
				81 (109)		
PVM141	2000 r/min			102 (137)	483 (356)	66 (145)
			1600 r/min			

# Specifications and Performance

## Variable Speed Drive

Variable Speed Performance- System Pressure vs Speed

Model Series	Max Speed "E" (rpm)	Max Speed "M" (rpm)	Min Speed (rpm)	Nominal Pressure (bar)	Peak Pressure (bar)	**	Inertia (kg-cm <sup>2</sup> )
PVM018	1800	2800	0	315	350		11.8
PVM020	1800	2800	0	230	280		11.8
PVM045	1800	2600	0	315	350		36.2
PVM050	1800	2600	0	230	280		33.9
PVM057	1800	2500	0	315	350		51.6
PVM063	1800	2500	0	230	280		50.5
PVM074	1800	2400	0	315	350		78.1
PVM081	1800	2400	0	230	280		72.7
PVM098	1800	2200	0	315	350		131.6
PVM106	1800	2200	0	230	280		122.7
PVM131	1800	2000	0	315	350		213.5
PVM141	1800	2000	0	230	280		209.7

\* Valve plate type

\*\*Less than 0.5 second.

### PVM System Pressure vs. Shaft Speed

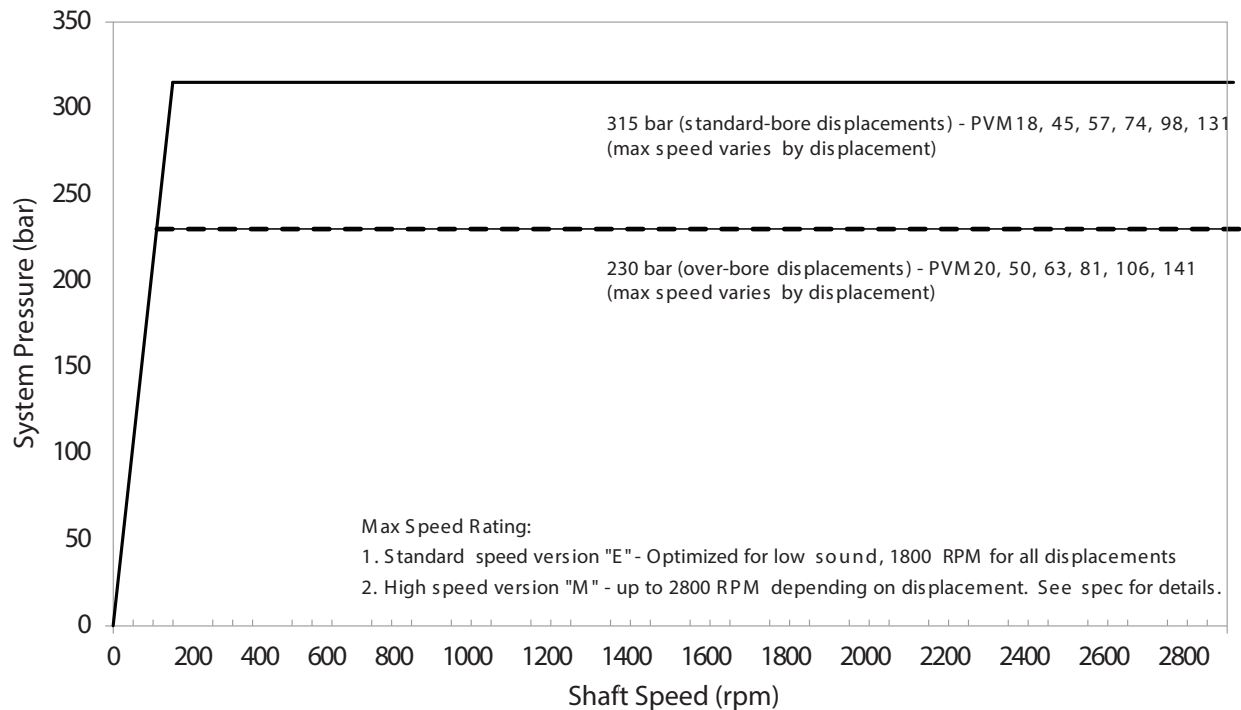

Test condition: Mineral oil SAE 10W, oil temperature 49° C (120° F), 1 bar absolute inlet pressure.

# Control Options

## Pressure Compensator Control – Code A

The pump will provide a continuously modulated flow to meet changing load demands at a pre-adjusted compensator pressure. At pressures below the compensator setting, the pump will operate at maximum displacement. See model code on page 4 for compensator pressure ranges.

**Warning:** The pressure compensator may be adjusted beyond the rated pressure of the pump. When adjusting the pressure limiter, install a 0-350 bar (0-5000 psi) gage in the outlet gage port and limit the pressure setting to the continuous rated pressure for the pump displacement shown on page 7.

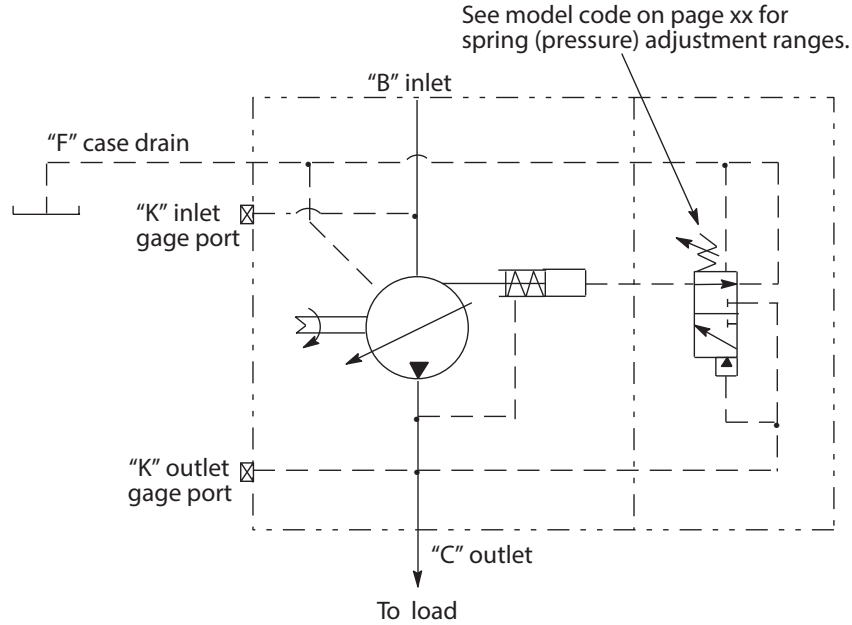

Industrial Pressure Cut-off Characteristics of Code A Pressure Compensator Control at 50°C (120°F), static conditions.

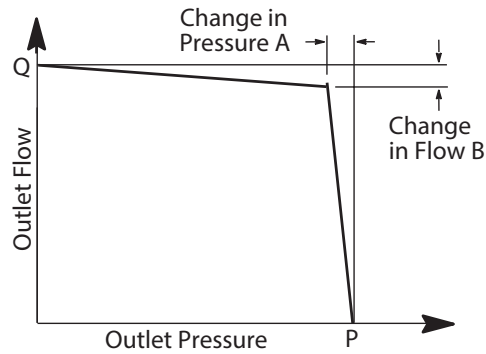

Pressure Cut-off Characteristics of Pressure Compensator Control @ 50°C (120°F), Static Conditions

Model Series	Max. Speed r/min	"Q" Outlet Flow l/min (USgpm)	"P" Outlet Pressure bar (psi)	A bar (psi)	B L/min (USgpm)
PVM018	1800	32 (8.5)	315 (4568)	2,8 (40)	4,5 (1.2)
PVM020	1800	35 (9.25)	230 (3300)	2,8 (40)	4,5 (1.2)
PVM045	1800	76 (20)	315 (4568)	10 (150)	4,5 (1.2)
PVM050	1800	87 (23)	230 (3300)	10 (150)	4,5 (1.2)
PVM057	1800	102 (27)	315 (4568)	3,5 (51)	14 (3.7)
PVM063	1800	113 (29)	230 (3300)	7,4 (107)	7,6 (2.00)
PVM074	1800	127 (33.5)	315 (4568)	1,5 (22)	37 (9.8)
PVM081	1800	141 (37)	230 (3300)	1,5 (22)	37 (9.8)
PVM098	1800	179 (47)	315 (4568)	1,5 (22)	25 (6.6)
PVM106	1800	195 (51.5)	230 (3300)	1,5 (22)	20 (5.3)
PVM131	1800	229 (60.5)	315 (4568)	3,5 (51)	19 (5.0)
PVM141	1800	238 (63)	230 (3300)	3,5 (51)	14 (3.70)

# Control Options

Mobil Pressure Cut-off  
 Characteristics of Pressure  
 Compensator Control at  
 93°C (200°F), static conditions.

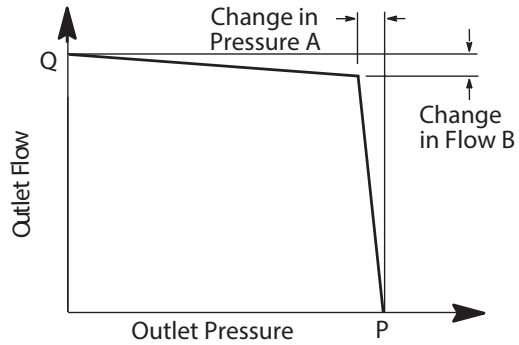

Pressure Cut-off Characteristics of Pressure Compensator Control @ 93°C (200°F), Static Conditions

Model Series	Rated Speed r/min	"Q" Outlet Flow l/min (USgpm)	"P" Outlet		
			Pressure bar (psi)	A bar (psi)	B L/min (USgpm)
PVM018	2800	42 (11)	315 (4568)	2,8 (40)	4,5 (1.2)
PVM020	2800	52 (14)	230 (3300)	2,8 (41)	4,5 (1.2)
PVM045	2600	115 (30)	315 (4568)	10 (150)	4,5 (1.2)
PVM050	2600	125 (33)	230 (3300)	10 (150)	4,5 (1.2)
PVM057	2500	140 (37)	315 (4568)	3,5 (50)	14 (3.7)
PVM063	2500	159 (42)	230 (3300)	7,4 (107)	11,4 (3.00)
PVM074	2400	174 (46)	315 (4568)	1,5 (20)	37 (9.8)
PVM081	2400	185 (49)	230 (3300)	1,5 (22)	37 (9.8)
PVM098	2200	217 (57)	315 (4568)	1,5 (20)	32 (8.4)
PVM106	2200	234 (62)	230 (3300)	1,5 (22)	24 (6.33)
PVM131	2000	253 (67)	315 (4568)	1,0 (15)	23 (6.0)
PVM141	2000	258 (68)	230 (3300)	7,0 (100)	14 (3.70)

# Control Options

## Load Sensing and Pressure Compensator Control – Code B or C

The pump will provide power matching of pump output to system load demand, maximizing efficiency and improving load metering characteristics of any directional control valve installed between the pump and the load.

Load sensing ensures that the pump always provides only the amount of flow needed by the load. At the same time, the pump operating pressure adjusts to the actual load pressure plus a pressure differential required for the control action. When the system is not demanding power, the load sense control will operate in an energy-saving stand-by mode.

Typically, the differential pressure is that between the pressure inlet and service port of a proportionally controlled directional valve, or a load sensing directional control valve. See the model code on page 4 for differential pressure settings for load sensing.

If the load pressure exceeds the system pressure setting, the pressure compensator de-strokes the pump. The load sensing line must be as short as possible and can also be used for remote control or unloading of the pump pressure. For remote control purposes, it is recommended that you contact your Danfoss representative for the correct configuration of the control.

**Warning:** The pressure compensator may be adjusted beyond the rated pressure of the pump. When adjusting the pressure limiter, install a 0-350 bar (0-5000 psi) gage in the outlet gage port and limit the pressure setting to the continuous rated pressure for the pump displacement shown on page 7.

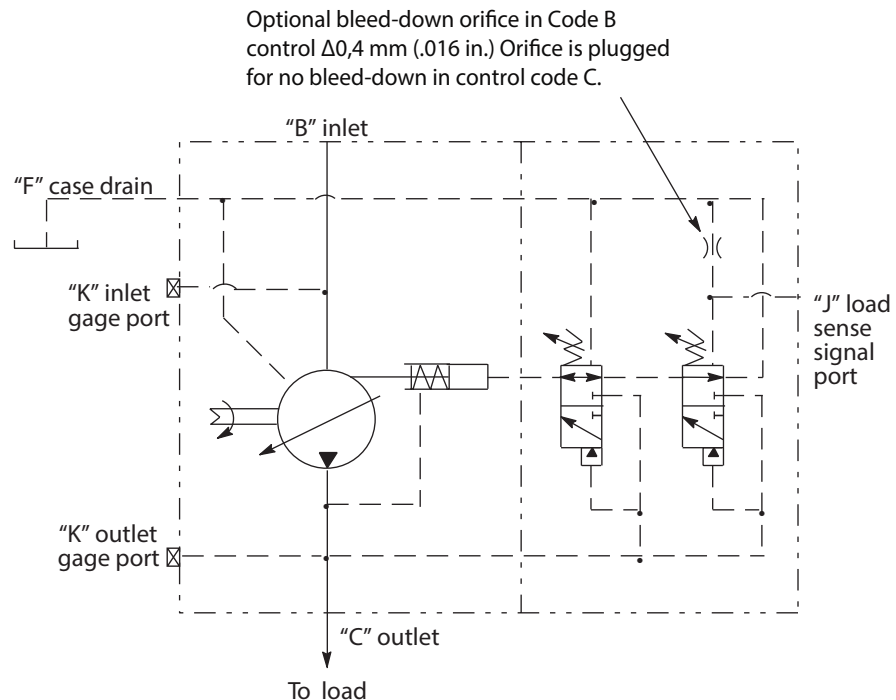

# Control Options

## Remote Pressure Control W Compensator – Code E (Model 018-050 only)

Remote relief valve is to be connected to pilot port "J" through necessary external piping. Standard differential pressure of 20 bar is set at RPC spool. The required outlet pressure (below 280 bar) can be set by adjusting remote relief valve setting. Once pressure reaches preset value, flow across remote relief valve starts, this results in RPC spool movement due to pressure imbalance. This will de-stroke the pump to maintain the set pressure.

Secondary pressure compensator is provided to limit the max pressure setting as a fail safe measure. The delta pressure is factory set which can not be changed.

**\* Flow Compensator is not available with RPC.**  
**\*\* Model code position 20, 21 is "10" and specifies 10 bar (145psi) RPC spool setting**

**\*\*Remote relief valve is not included in supply scope of the pump.**

### With Pressure & Flow Compensator (E)

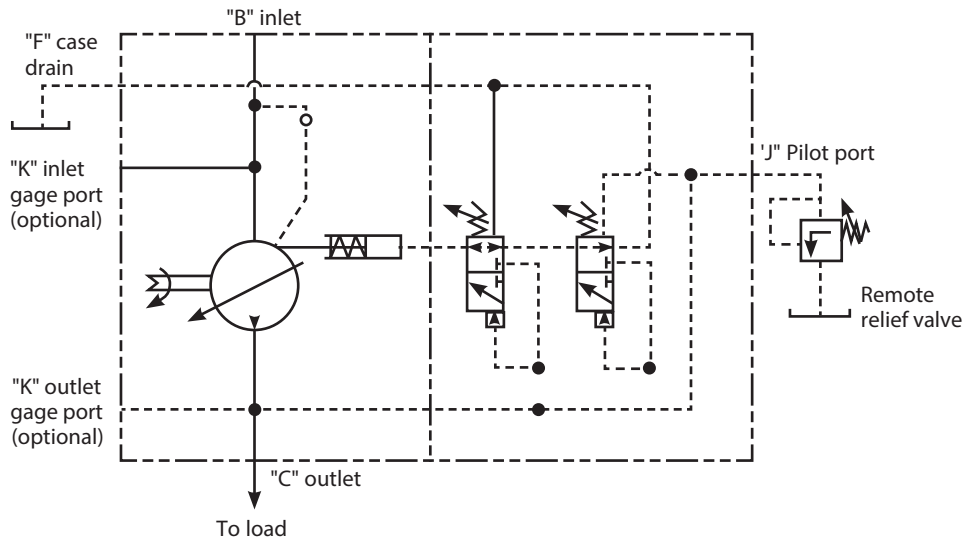

Delta Pressure setting at control valve - bar (psi)	14 - 24 (200 - 350)
Control fluid consumption - lpm (gpm)	4.5 (1.2) max.
Recommended flow rating of remote relief valve - lpm (gpm)	3 - 5 (0.8 - 1.32)
Recommended Danfoss Relief Valve part number	RV5-10-S-0-50

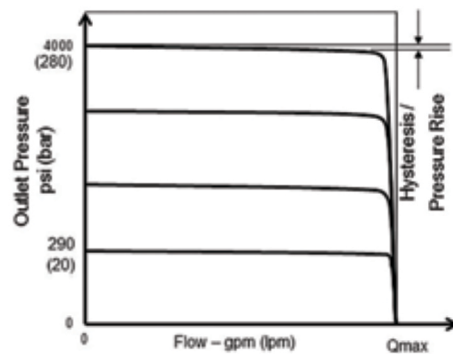

# Control Options

## Industrial Control Compensator – Code E (Model 057-141 only)

This pump is intended for use when multiple, remote, or electronically controlled compensating settings, with or without load sensing, are desired.

Pressure compensation is obtained when an internal plug is removed, the load-sense signal port is kept plugged, and internal pilot pressure is applied to the spring chamber of the control spool. For pressure compensation with load sensing, the internal plug stays, the load-sense signal port is unplugged, and pilot pressure is externally applied.

An external relief valve (not supplied) controls spring chamber pressure. The externally adjustable spring determines the differential pressure setting of the control. Outlet pressure is limited to the valve of the spring chamber (pressure port) pressure, plus control differential pressure.

Spring chamber (pilot) pressure is separated from outlet pressure by an internal orifice. Outlet pressure shifts the spool when pressure drop across the orifice reaches the differential pressure setting and the pump de-strokes.

The relief valve can be mounted to an NFPA-D03/ISO 4401-03 pad on the pump control, or remotely located via tapping and blanking plates installed on the pad.

The standard factory-set differential pressure setting of the pump control is 20 bar (290 psi) and is not specified in the pump model number. Any other ordered differential pressure, within the control's adjustable pressure range of 17-35 bar (247-508 psi), will be specified in the model number.

### With Pressure & Flow Compensator (E)

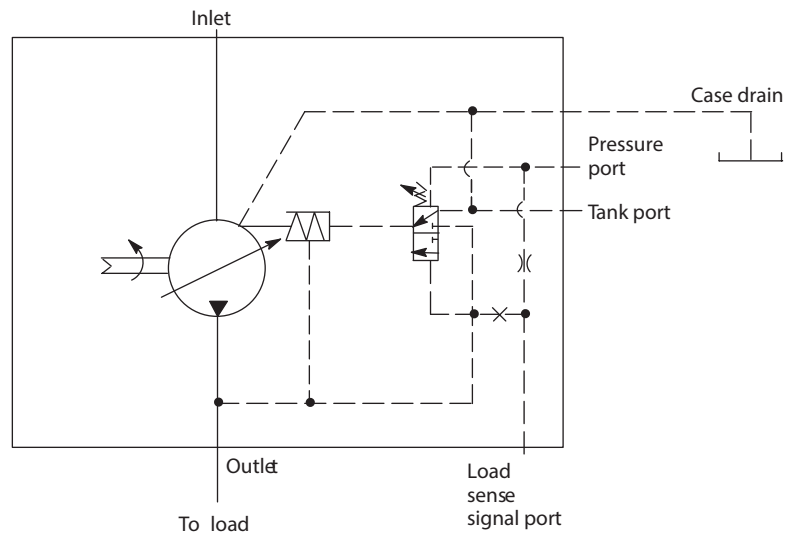



# Control Options

## Power Control-Code L

The Power control limits the maximum torque output by the piston pump by reducing the displacement as pressure increases hence limiting the power rating at a given speed.

As pressure increases the pump displacement is reduced such that the set torque value is not exceeded.

The torque can be set between 20-90% of rated torque for given displacement at 1800 rpm (model code pos 22-23, ref table below for range of torque).

**Warning:** The pressure compensator may be adjusted beyond the rated pressure of the pump. When adjusting the pressure limiter, install a 0-350 bar (0-5000 psi) gauge in the outlet gauge port and limit the pressure setting to the continuous rated pressure for the pump displacement shown on page 7.

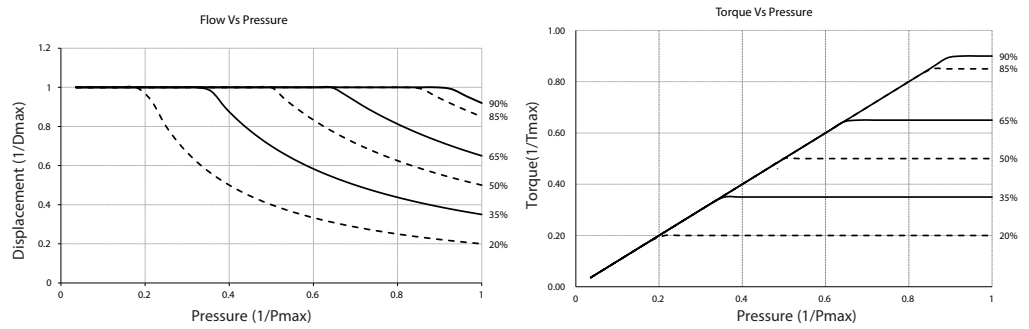
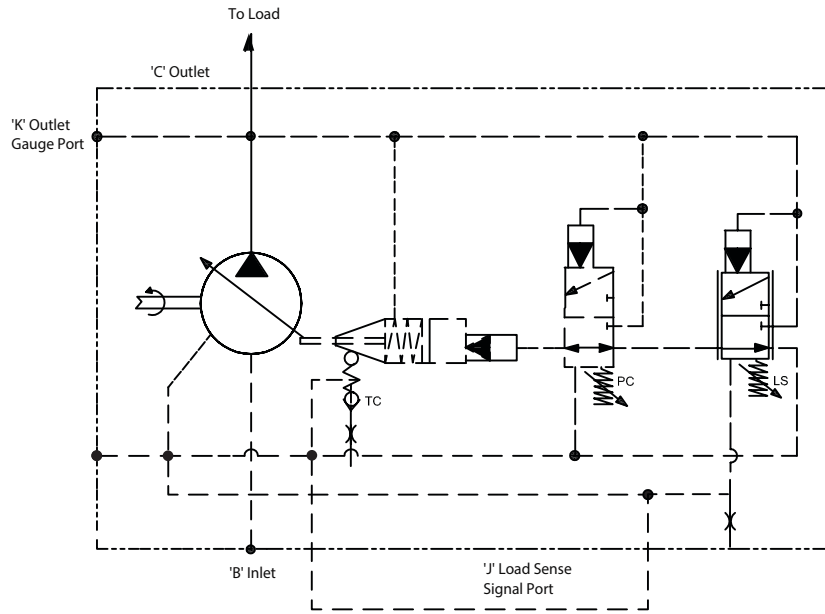

Characteristics of Code L Power Control at 50°C (120°F), static conditions.

### Torque setting range by displacement

Displacement (cc)	Rated Torque lb-in (N-m)	Min torque setting lb-in (N-m), 20% of rated torque*	Max torque setting lb-in (N-m), 90% of rated torque
74	2920 (330)	584 (66)	2628 (297)
81	2626 (297)	525 (59)	2363 (267)

\* for Minimum torque setting (20%) the pump may not deliver the flow at higher pressure. Please contact Danfoss Engineering for flow generated at max pressure

# Performance

Quiet version, optimized for 1000-1800 rpm (E), PVM074/PVM081

Power Control -code L

Performance curves for 74 & 81 cc with power control, at various torque setting %

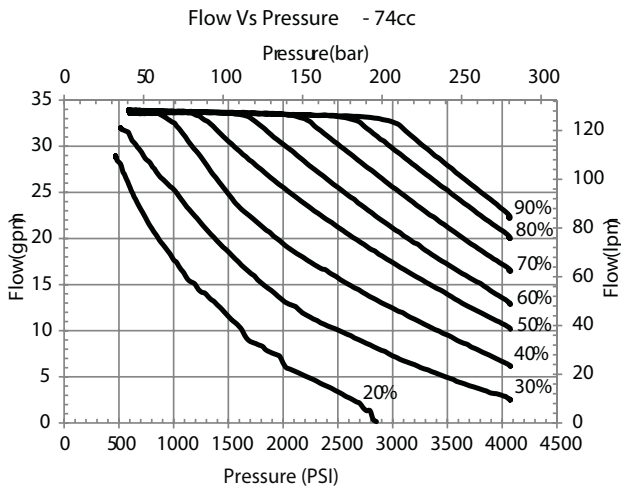

Mineral oil SAE 10W, oil temperature 49° C (120° F),  
1 bar absolute inlet pressure.  
Curves plotted at load sense delta P = 24 bar

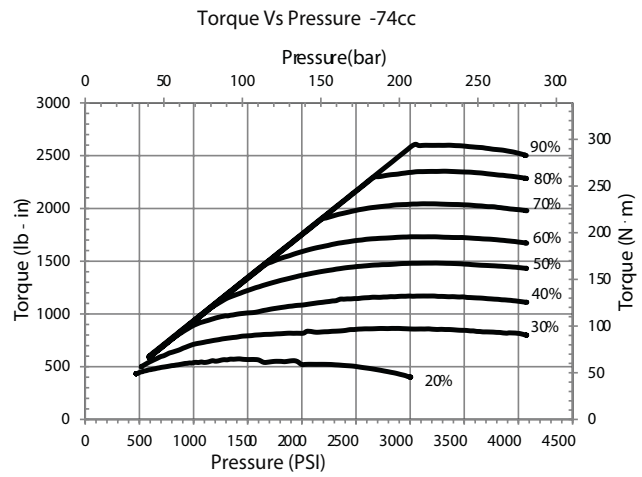

Mineral oil SAE 10W, oil temperature 49° C (120° F),  
1 bar absolute inlet pressure.  
Curves plotted at load sense delta P = 24 bar

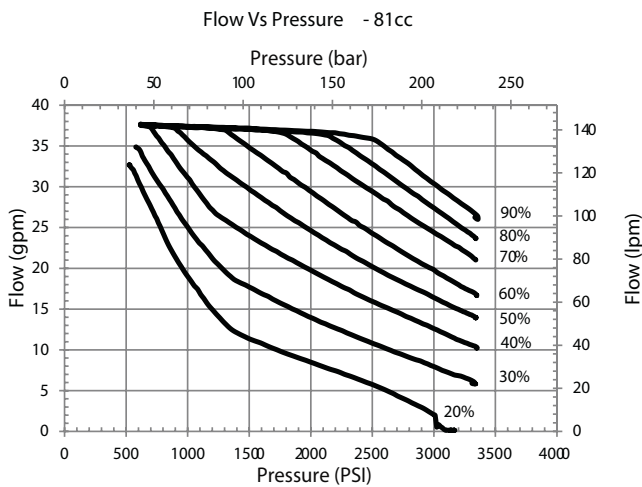

Mineral oil SAE 10W, oil temperature 49° C (120° F),  
1 bar absolute inlet pressure.  
Curves plotted at load sense delta P = 24 bar

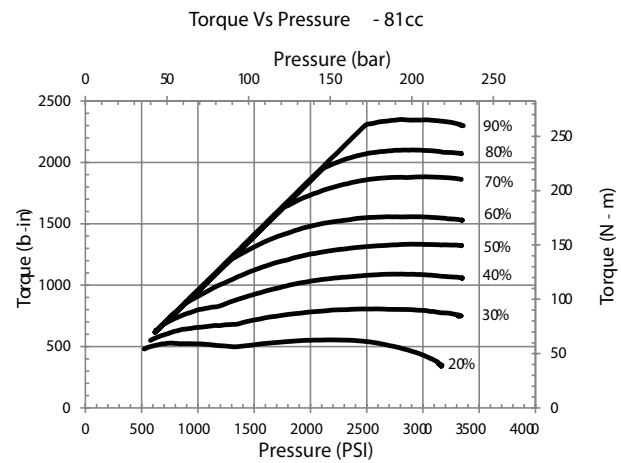

Mineral oil SAE 10W, oil temperature 49° C (120° F),  
1 bar absolute inlet pressure.  
Curves plotted at load sense delta P = 24 bar

# Performance

IndustrialPVM018

Typical Noise Levels at 1800 and 1200 r/min with Petroleum Oil (10W) at 50°C (120°F) and 1.0 bar absolute (0 psi gauge) Inlet

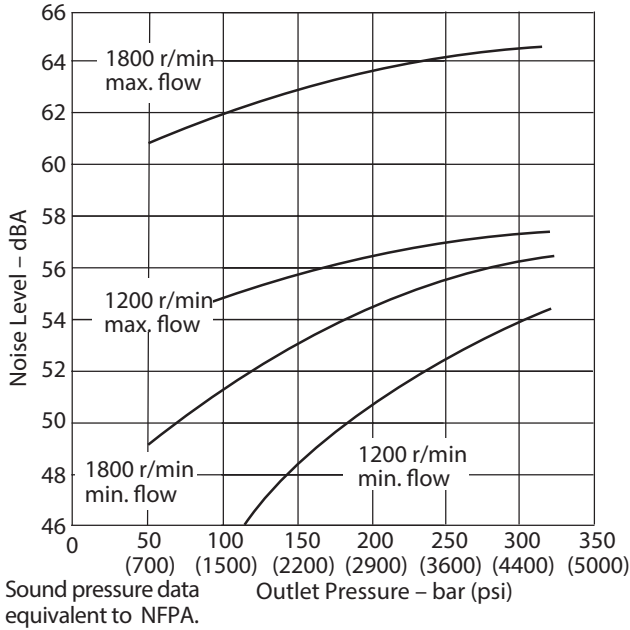

Delivery and Efficiency at 1800 r/min 50°C (120°F) and 1.0 bar absolute (0 psi gauge) Inlet

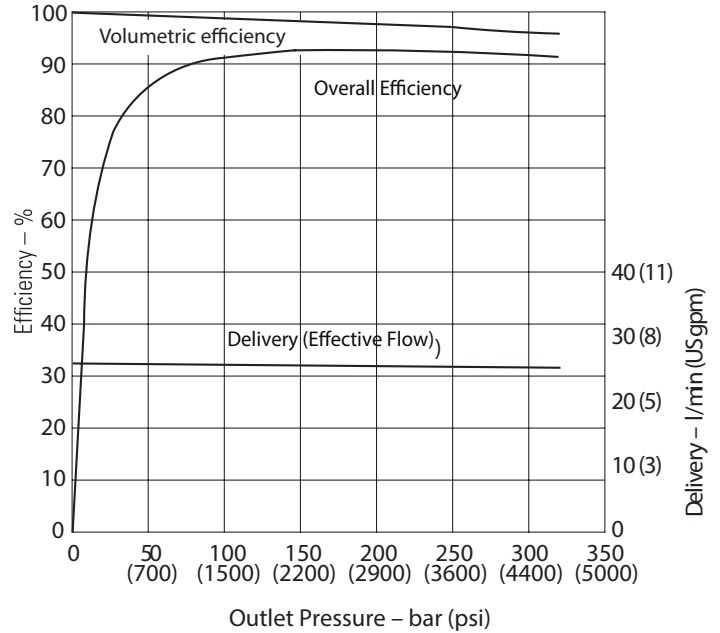

Typical Noise Levels at 1500 and 1000 r/min with Petroleum Oil (10W) at 50°C (120°F) and 1.0 bar absolute (0 psi gauge) Inlet

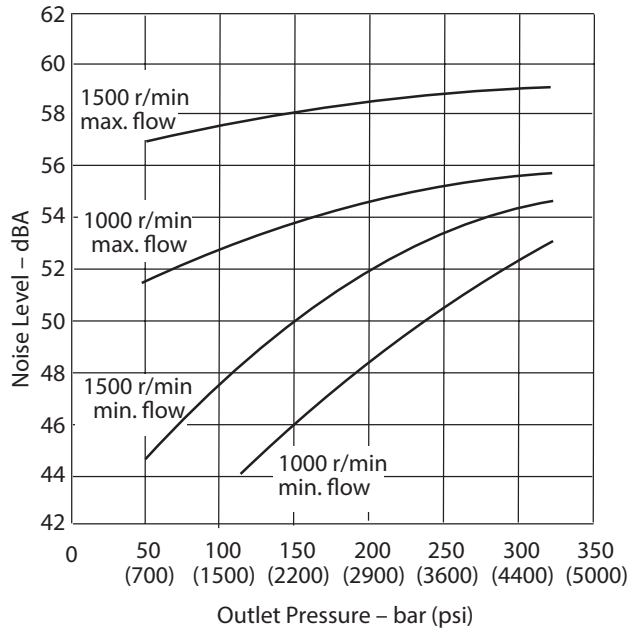

Input Torque and Power at 1800 r/min 50°C (120°F) and 1.0 bar absolute (0 psi gauge) Inlet

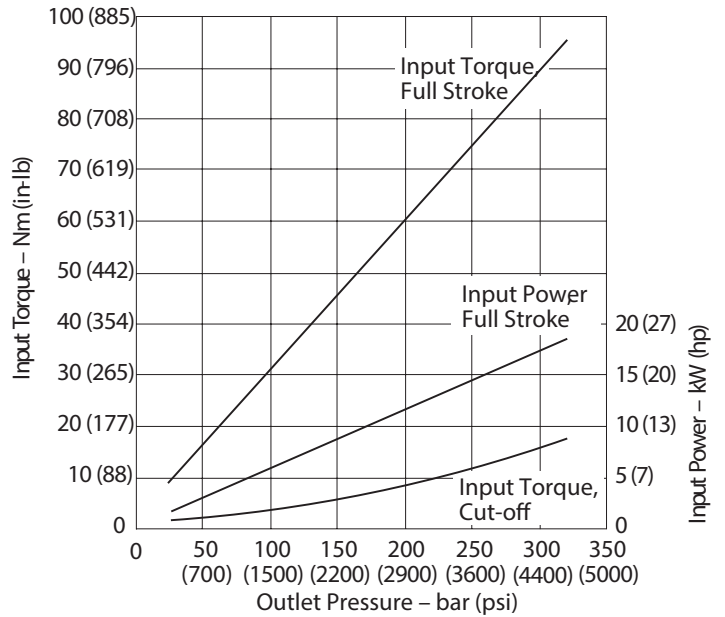

# Performance

Quiet version, optimized for 1000-1800 rpm (E) PVM018

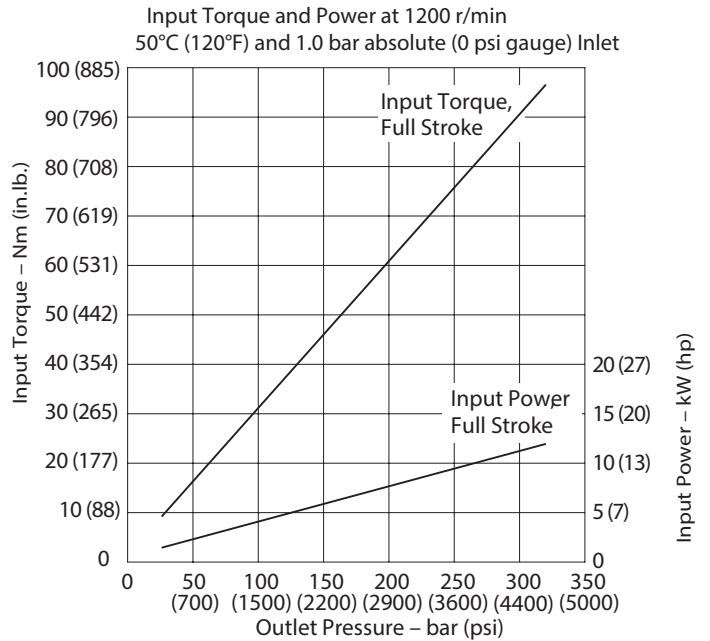
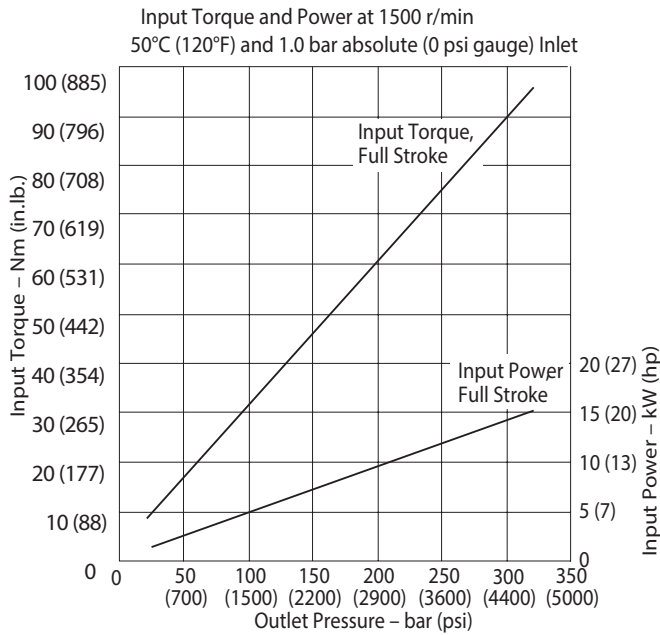
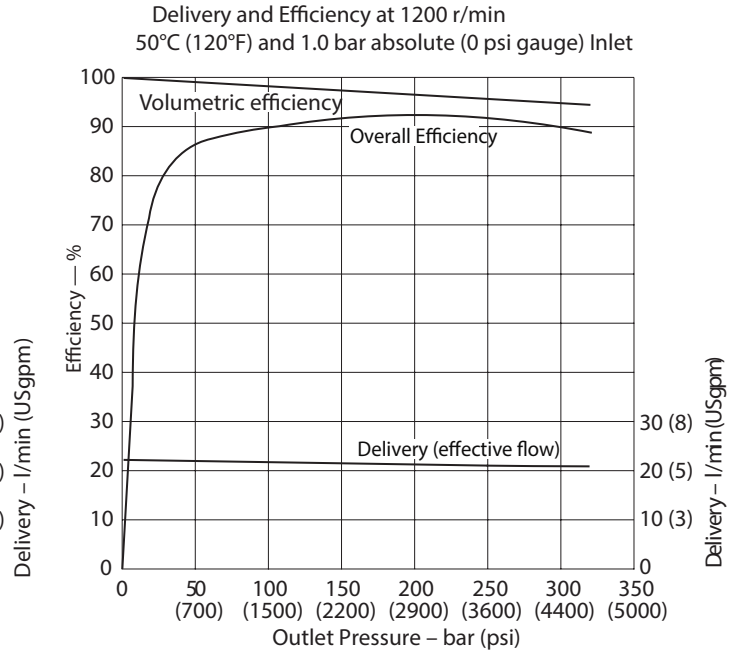
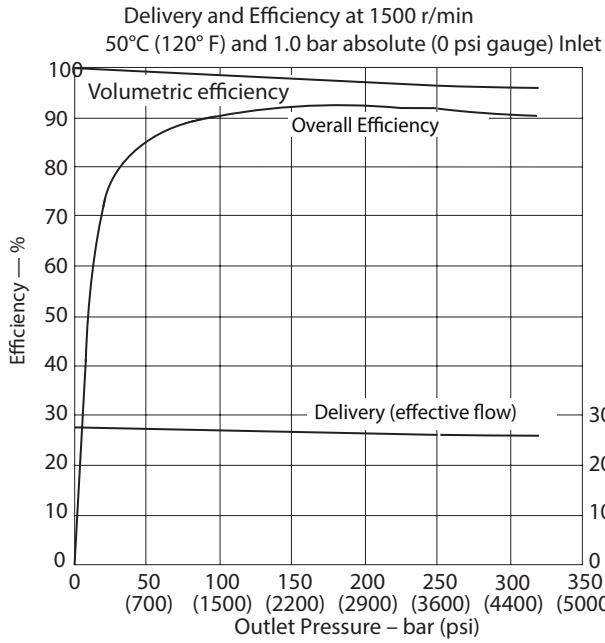

# Performance

Quiet version, optimized for 1000-1800 rpm (E) PVM018

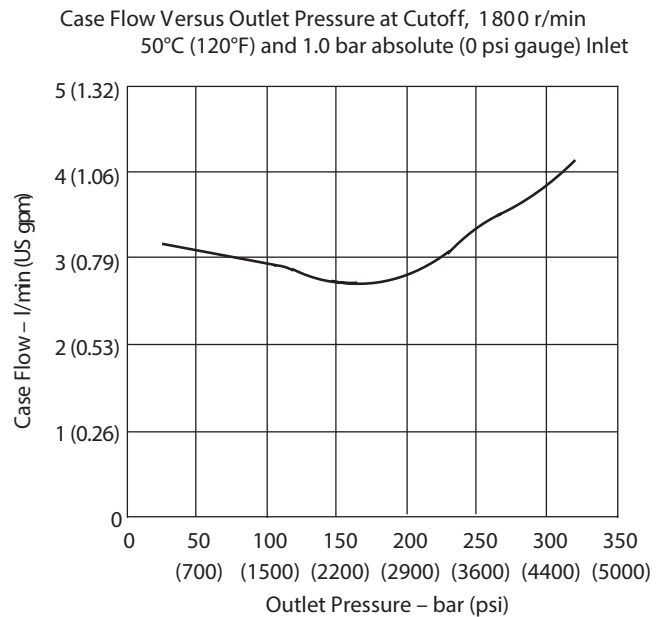
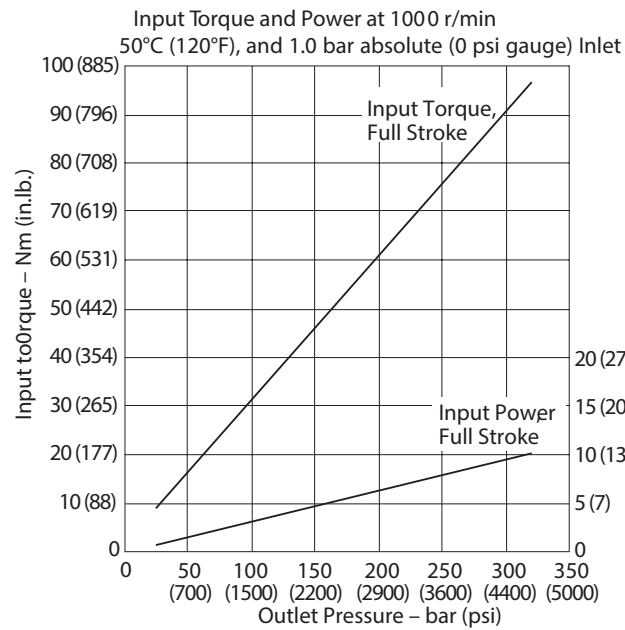
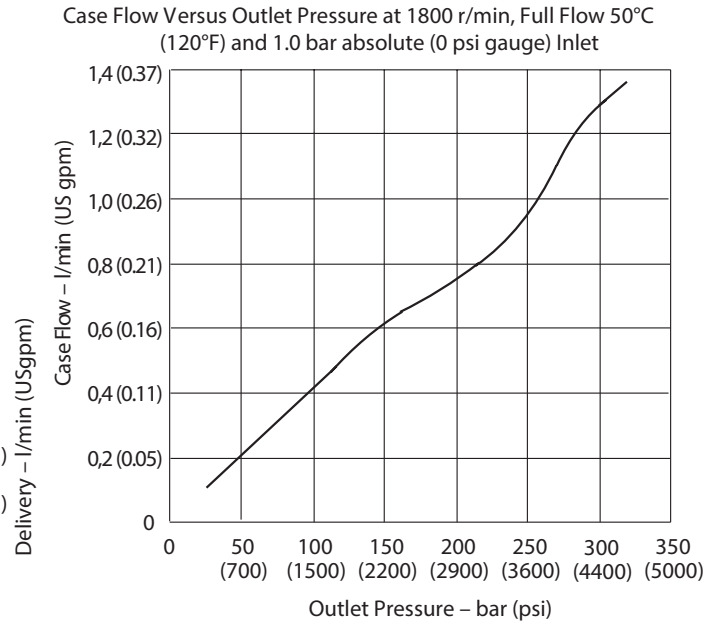
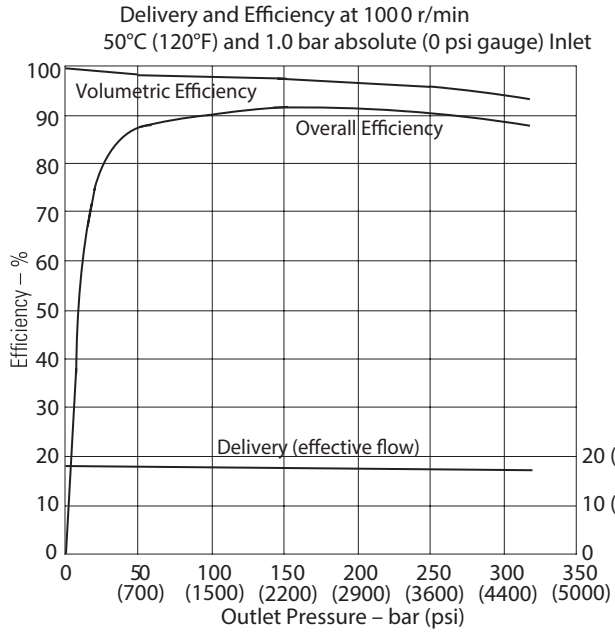

# Performance

Higher speed version (M)PVM018

Typical Noise Levels Petroleum Oil (10W) at 93°C (200°F), 1.0 bar absolute (0 psi gauge) Inlet (Sound pressure data equivalent to NFPA)

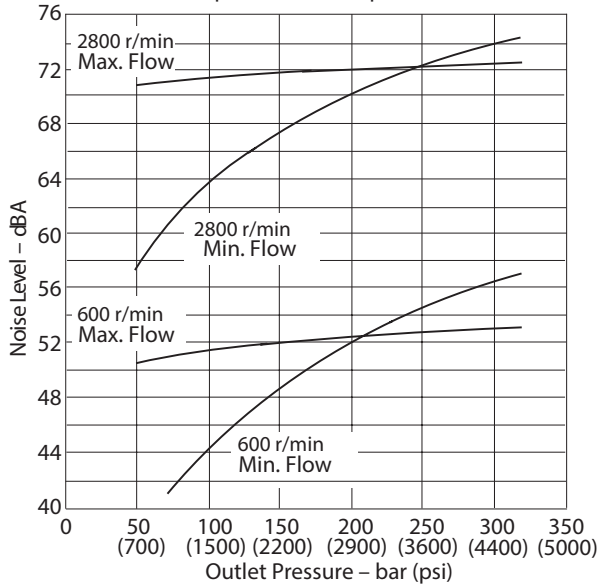

Delivery and Case Flow Versus Speed @93°C (200°F), full flow and 1.0 bar absolute (0 psi) gauge Inlet

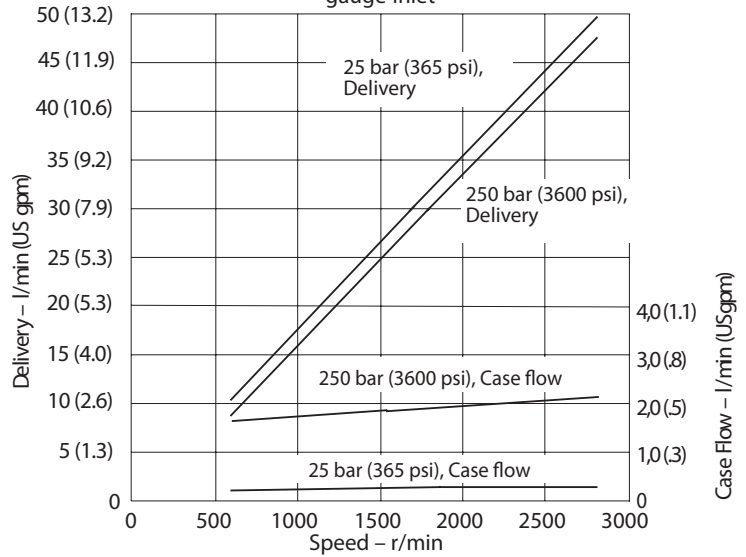

Overall Efficiency Versus Speed at 93°C (200°F) and 1.0 bar absolute (0 psi gauge) Inlet

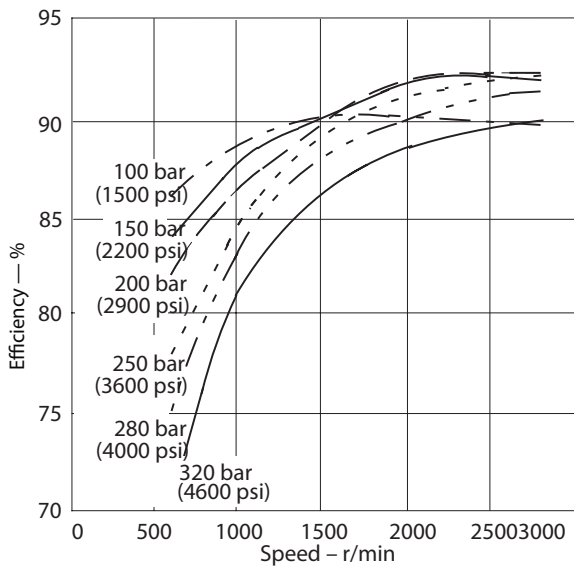

Input Torque Versus Speed @93°C (200°F), full flow and 1.0 bar absolute (0 psi) gauge) Inlet

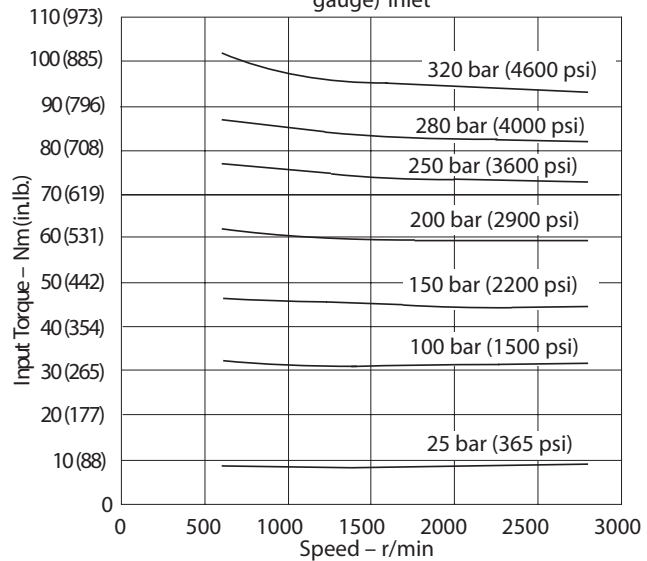

# Performance

Higher speed version (M)PVM018

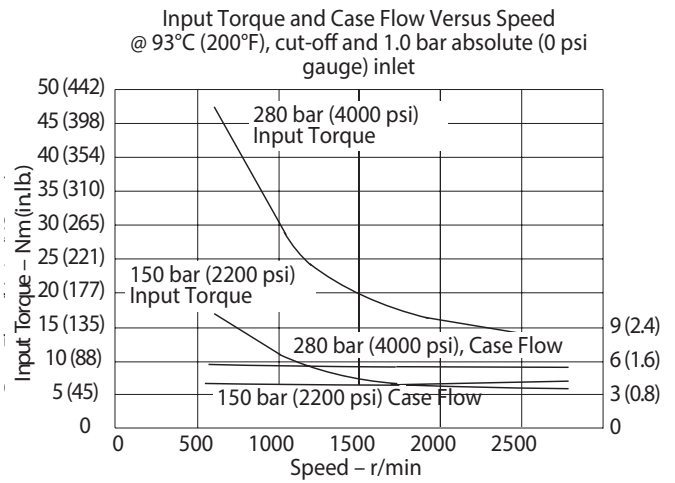
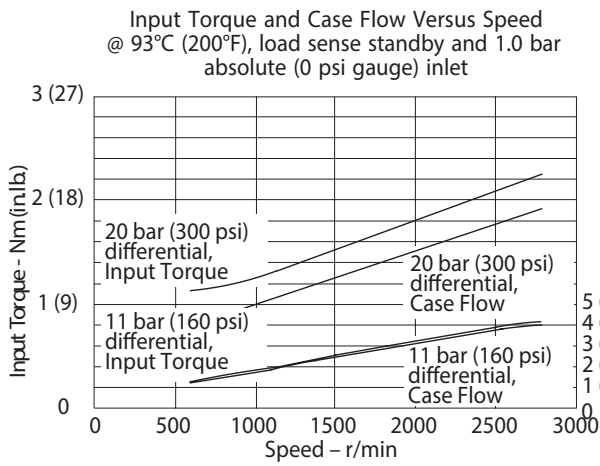
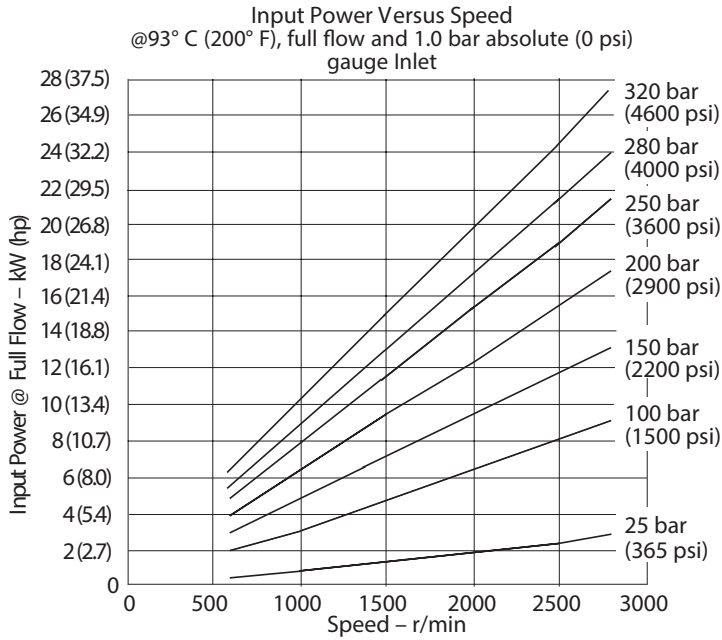

# Performance

Quiet version, optimized for 1000-1800 rpm (E) PVM020

Typical Noise Levels at 1800 and 1200 r/min with Petroleum Oil (10W) at 50°C (120°F) and 1.0 bar absolute (0 psi gauge) Inlet

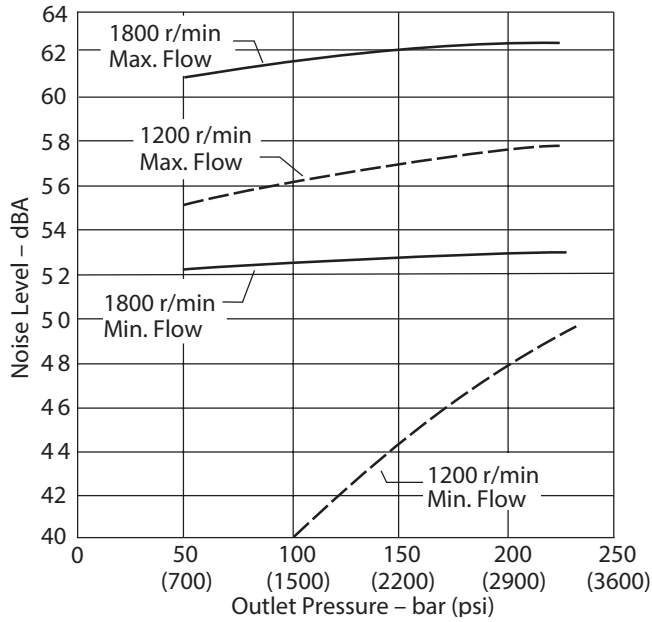

Delivery and Efficiency at 1800 r/min, 50°C (120°F), and 1.0 bar absolute (0 psi gauge) Inlet

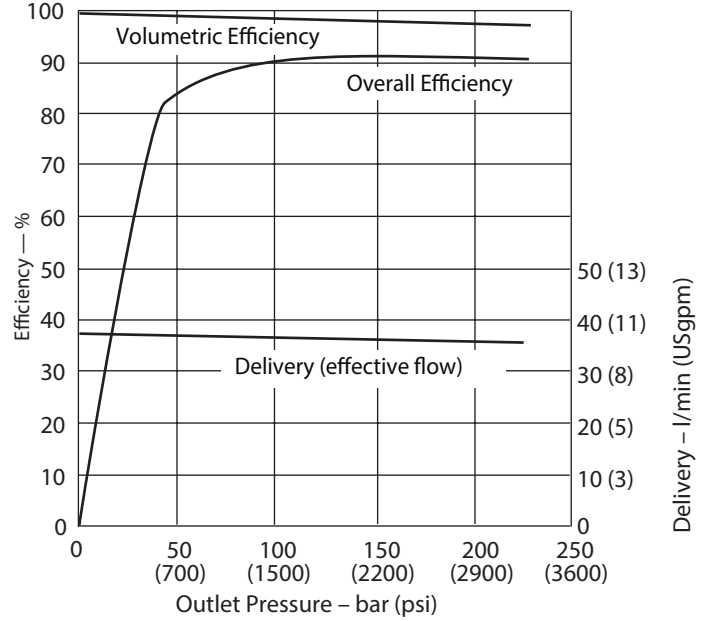

Typical Noise Levels at 1500 and 1000 r/min with Petroleum Oil (10W) at 50°C (120°F) and 1.0 bar absolute (0 psi gauge) Inlet

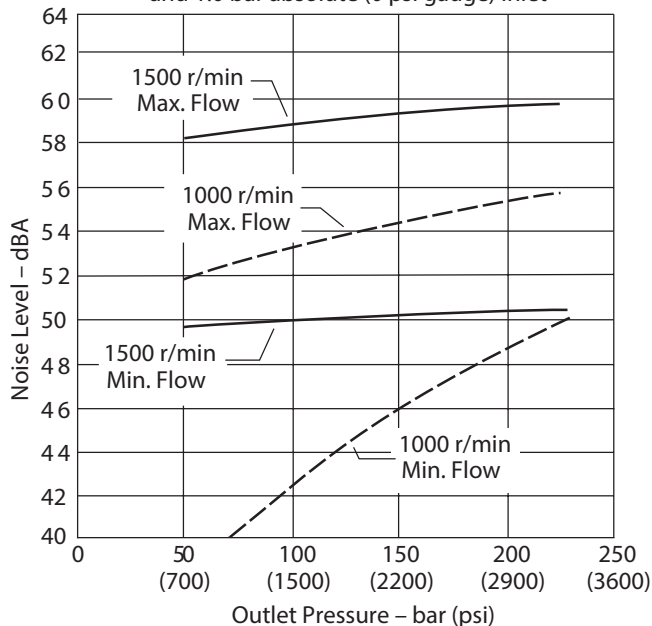

Input Torque and Power at 1800 r/min, 50°C (120°F), and 1.0 bar absolute (0 psi gauge) Inlet

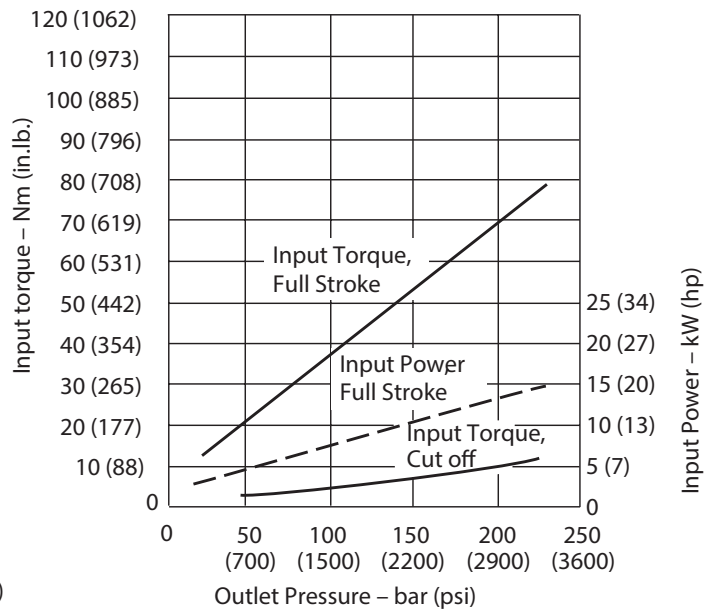

Sound pressure data equivalent to NFPA.



# Performance

Quiet version, optimized for 1000-1800 rpm (E) PVM020

Delivery and Efficiency at 1500 r/min, 50°C (120°F), and 1.0 bar absolute (0 psi gauge) Inlet

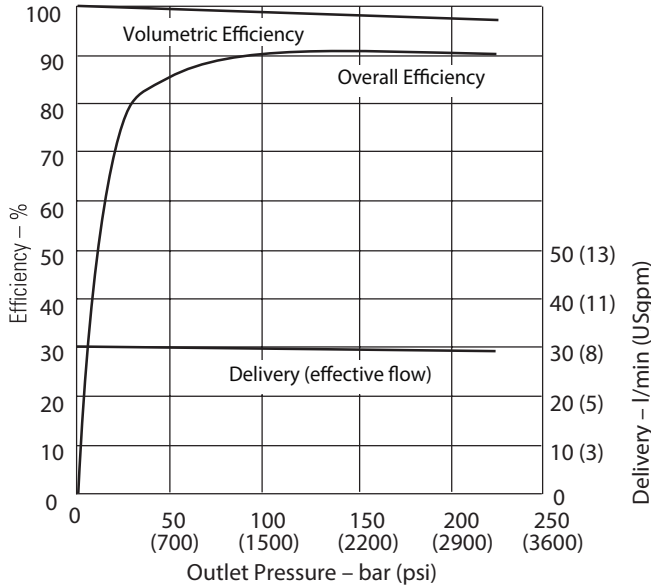

Delivery and Efficiency at 1200 r/min, 50°C (120°F), and 1.0 bar absolute (0 psi gauge) Inlet

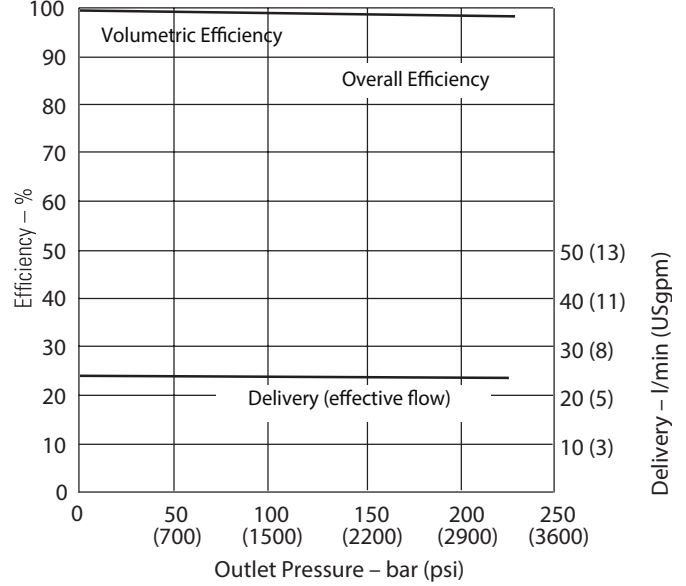

Input Torque and Power at 1500 r/min, 50°C (120°F), and 1.0 bar absolute (0 psi gauge) Inlet

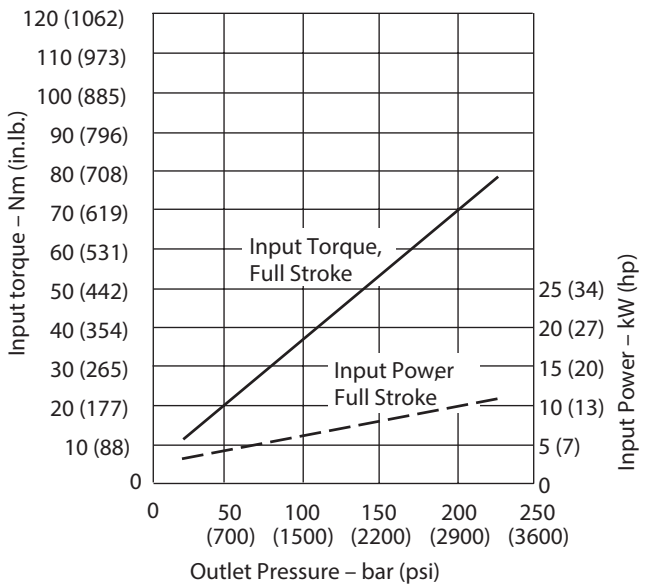

Input Torque and Power at 1200 r/min, 50°C (120°F), and 1.0 bar absolute (0 psi gauge) Inlet

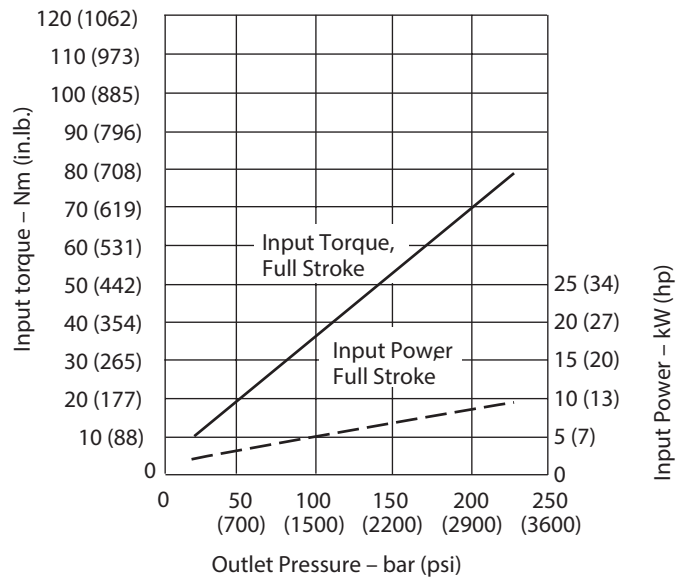

# Performance

Quiet version, optimized for 1000-1800 rpm (E) PVM020

Delivery and Efficiency at 1000 r/min, 50°C (120°F), and 1.0 bar absolute (0 psi gauge) Inlet

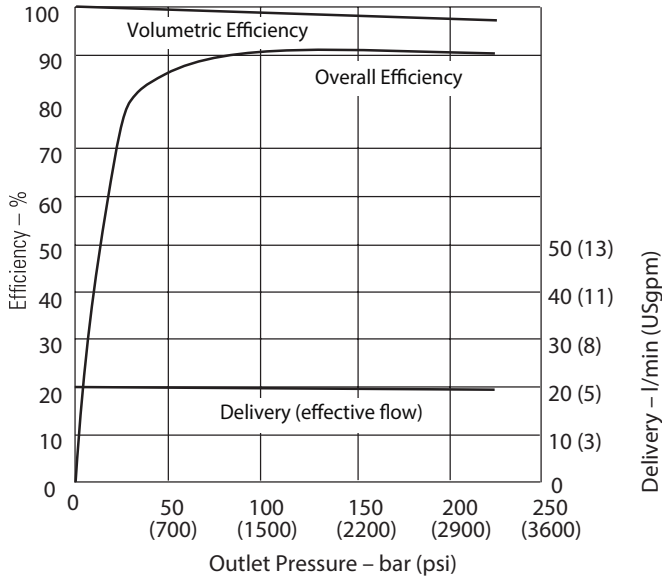

Case Flow versus Outlet Pressure at 1800 r/min, Full Flow, 50°C (120°F), and 1.0 bar absolute (0 psi gauge) Inlet

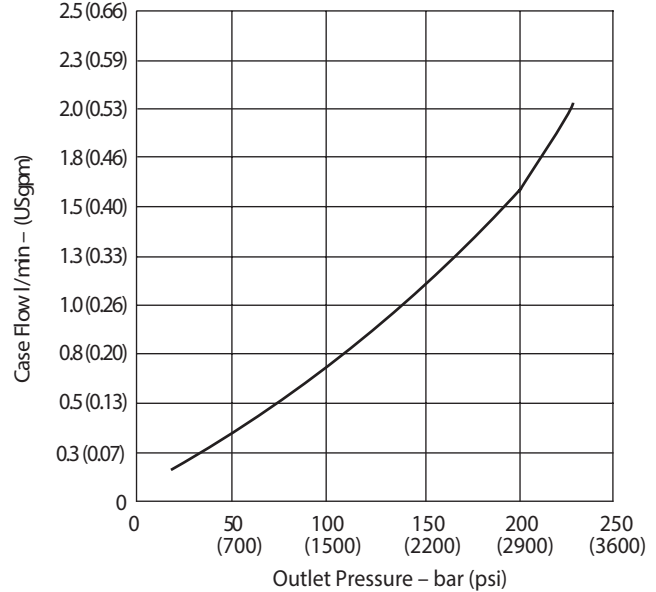

Input Torque and Power at 1000 r/min, 50°C (120°F), and 1.0 bar absolute (0 psi gauge) Inlet

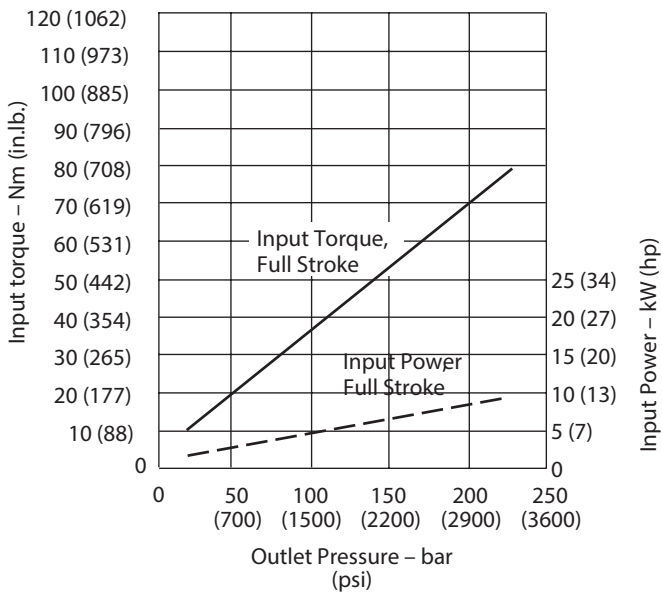

Case Flow versus Outlet Pressure at Cutoff, 1800 r/min, 50°C (120°F), and 1.0 bar absolute (0 psi gauge) Inlet

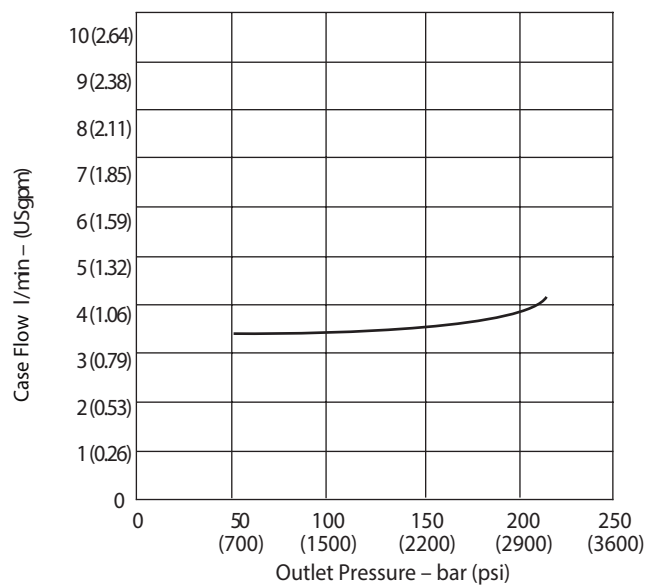

# Performance

Higher speed version (M)PVM020

Typical Noise Levels at 2800 & 600 r/min with Petroleum Oil (10W) at 93°C (200°F) and 1.0 bar absolute (0 psi gauge) Inlet

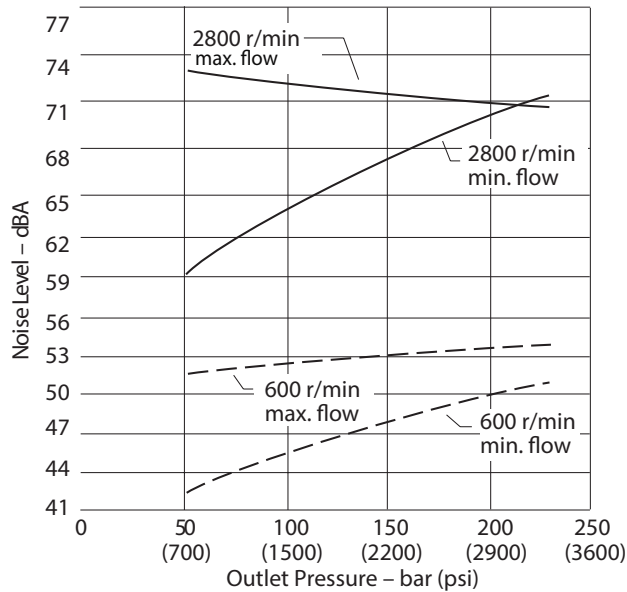

Sound pressure data equivalent to NFPA.

Overall Efficiency versus Speed at 93°C (200°F) and 1.0 bar absolute (0 psi gauge) inlet

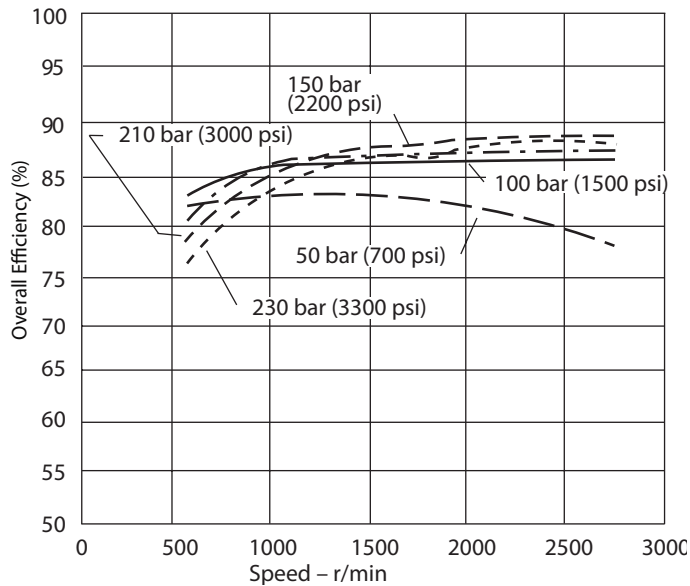

Delivery and Case Flow versus Speed at 93°C (200°F), Full Flow 1.0 bar absolute (0 psi gauge) inlet

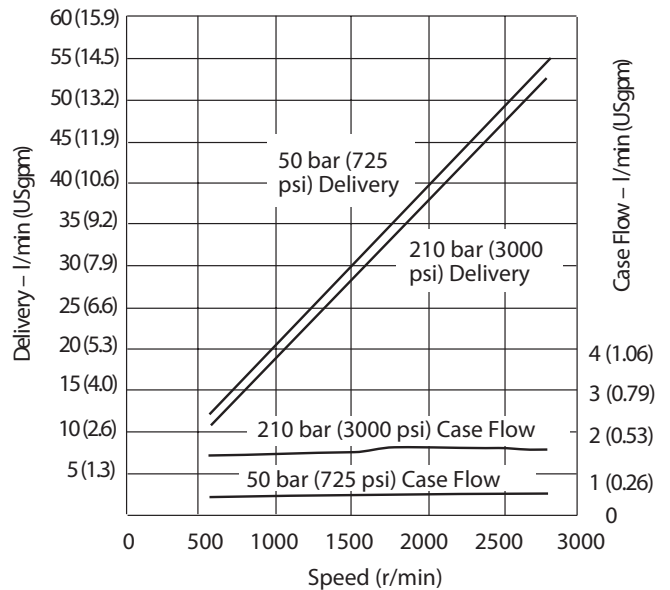

# Performance

Higher speed version (M)PVM020

Input Torque versus Speed at 93°C (200°F), Full Flow and 1.0 bar absolute (0 psi gauge) Inlet

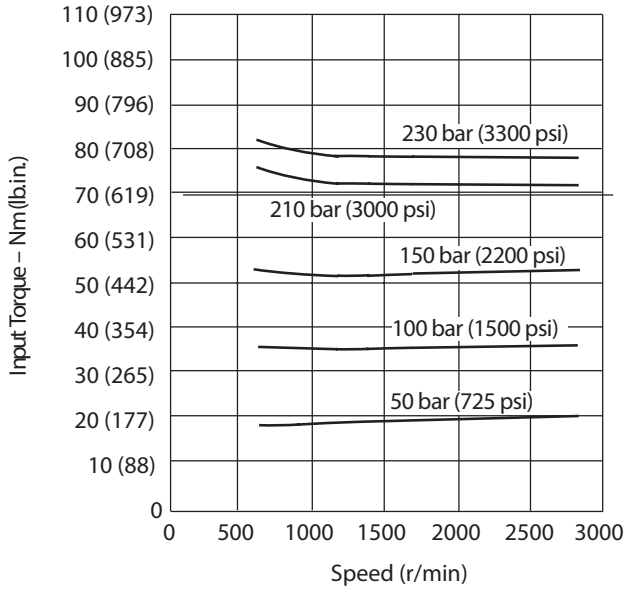

Input Power versus Speed at 93°C (200°F), Full Flow and 1.0 bar absolute (0 psi gauge) Inlet

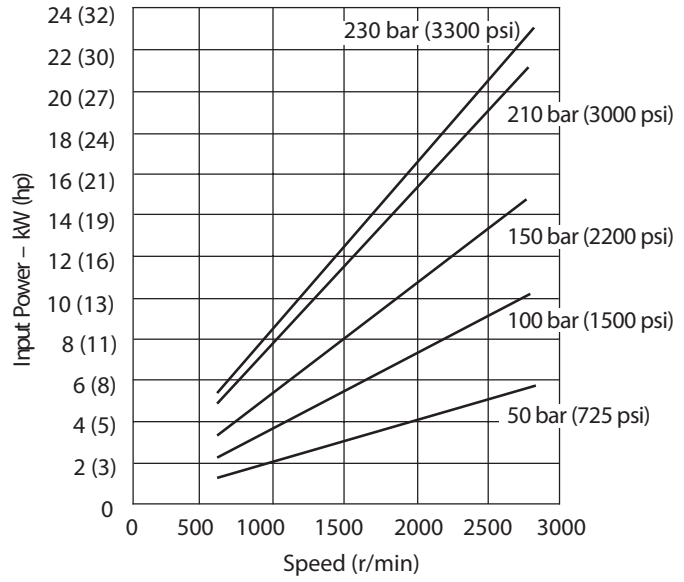

Input Torque and Case Flow versus Speed at 93°C (200°F), Load Sense Standby and 1.0 bar absolute (0 psi gauge) Inlet

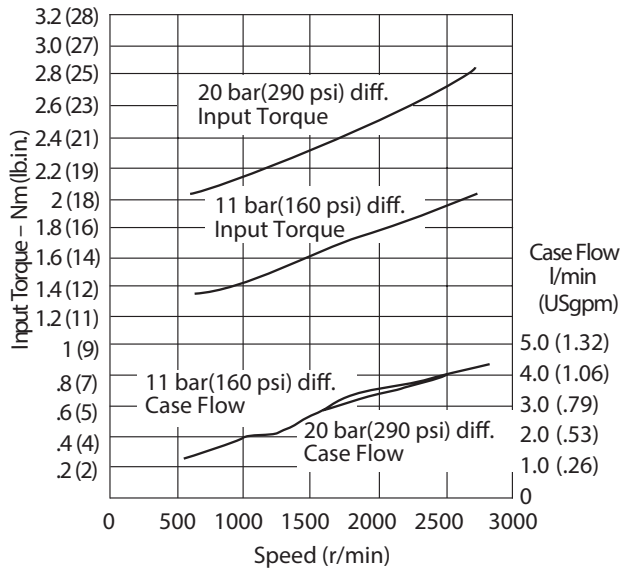

Input Torque and Case Flow versus Speed at 93°C (200°F), Pressure Limit Cut-off and 1.0 bar absolute (0 psi gauge) Inlet

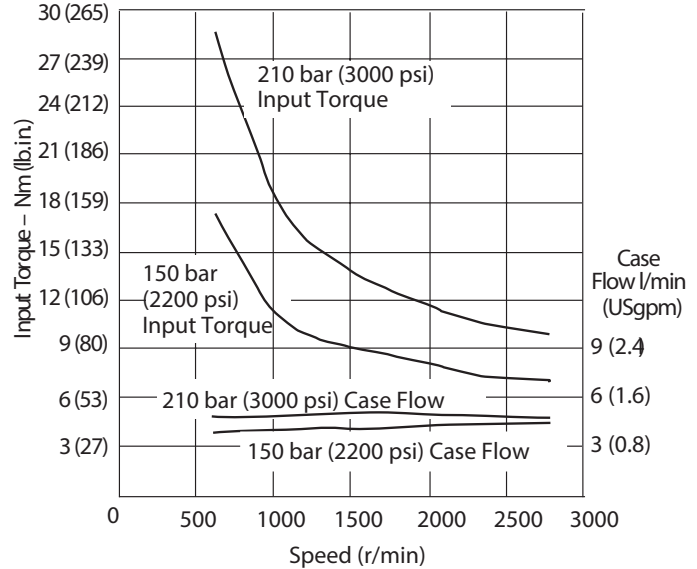

# Performance

Quiet version, optimized for 1000-1800 rpm (E) PVM045

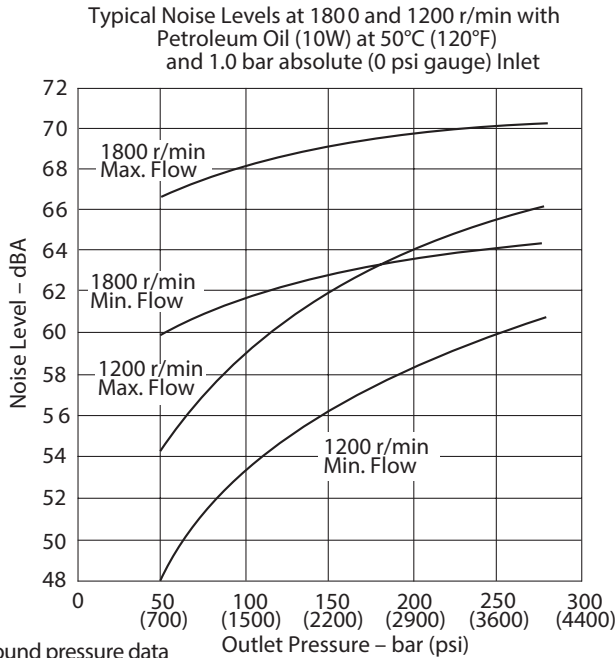

Sound pressure data equivalent to NFPA.

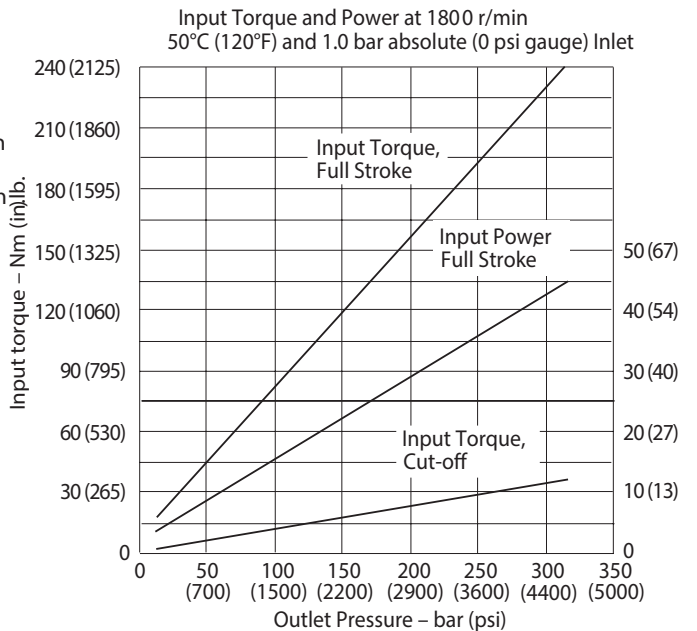
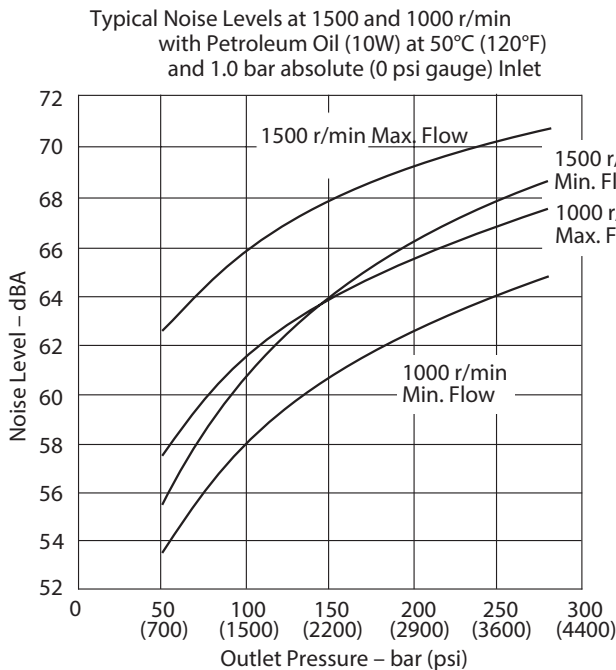
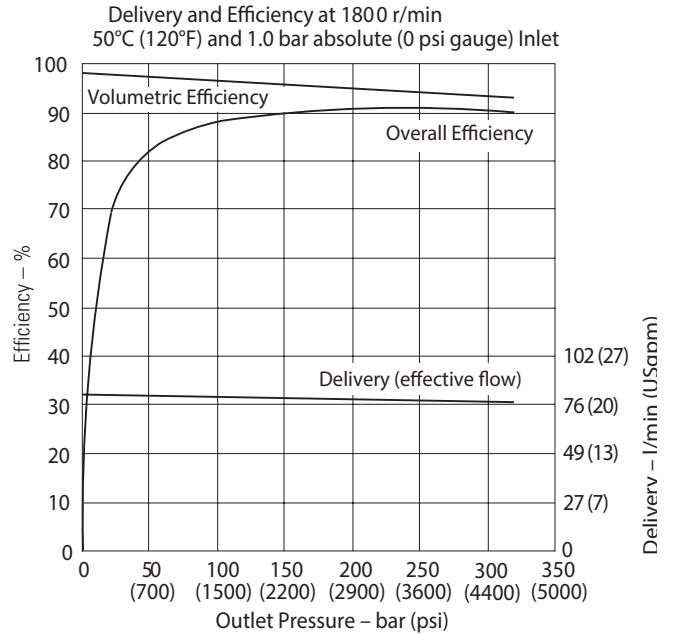

# Performance

Quiet version, optimized for 1000-1800 rpm (E) PVM045

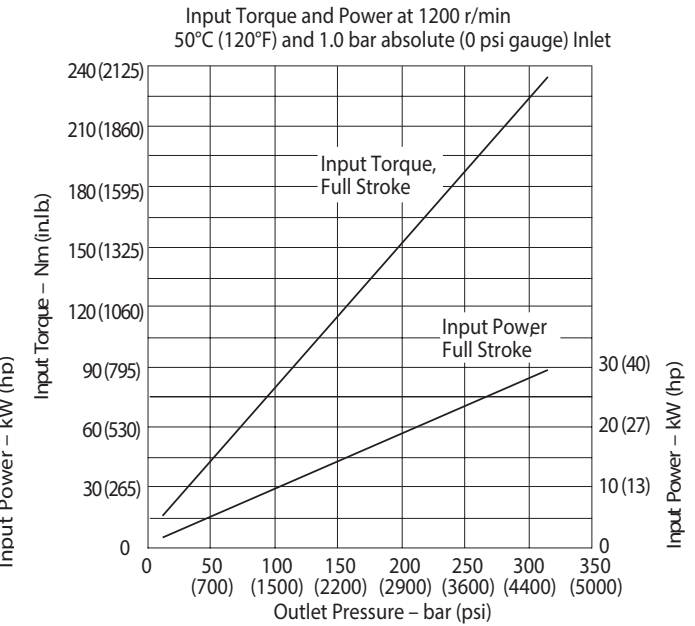
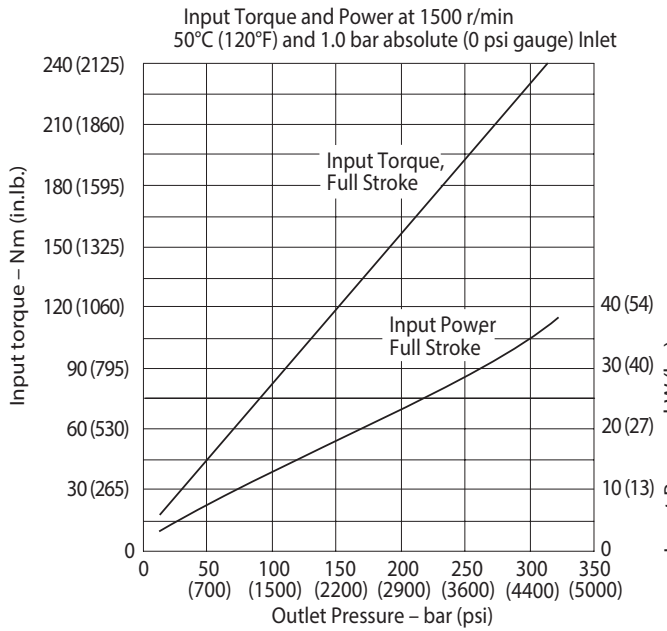
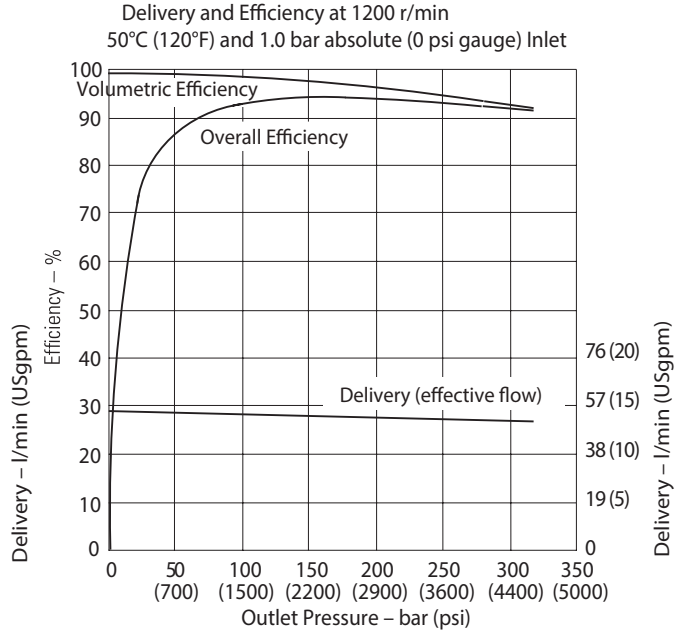
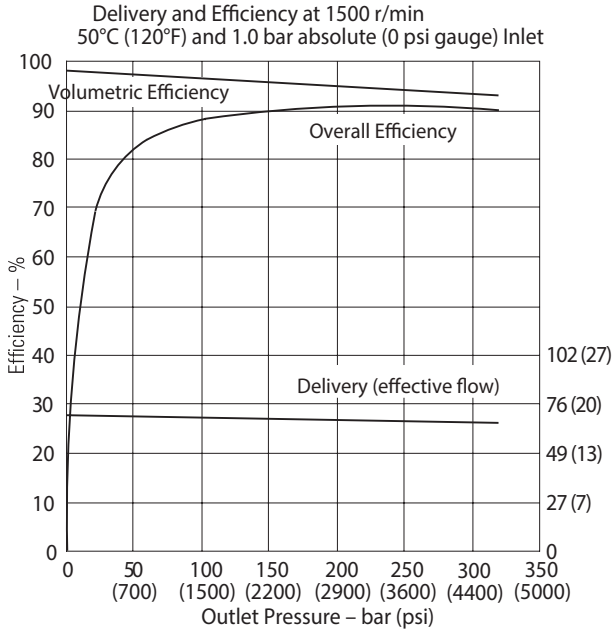

# Performance

Quiet version, optimized for 1000-1800 rpm (E) PVM045

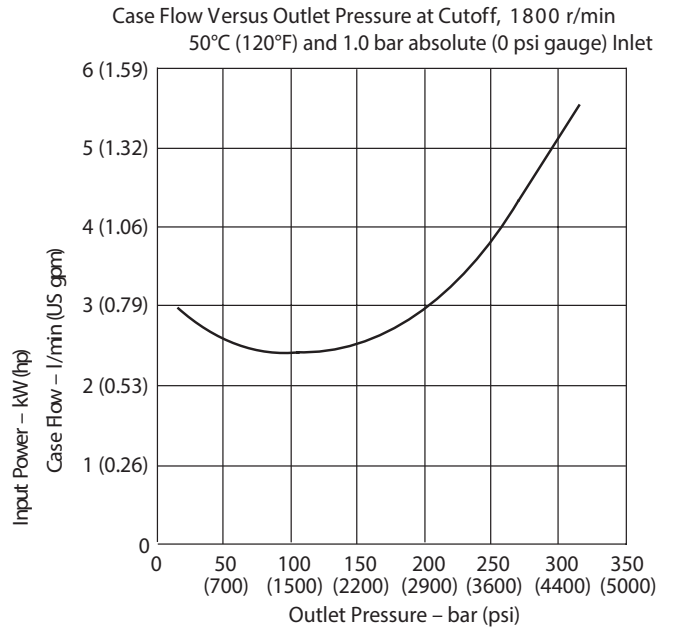
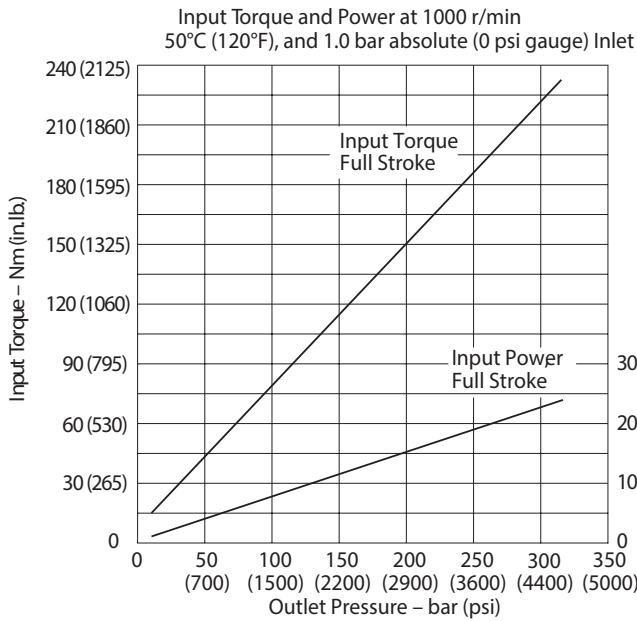
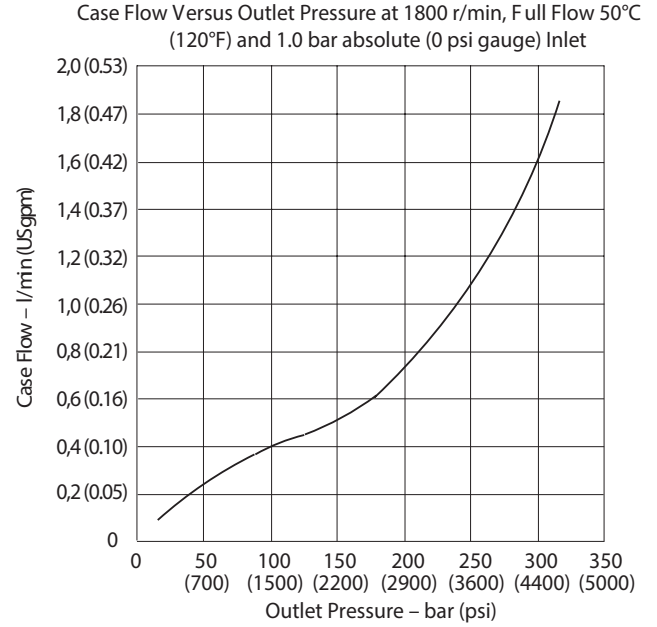
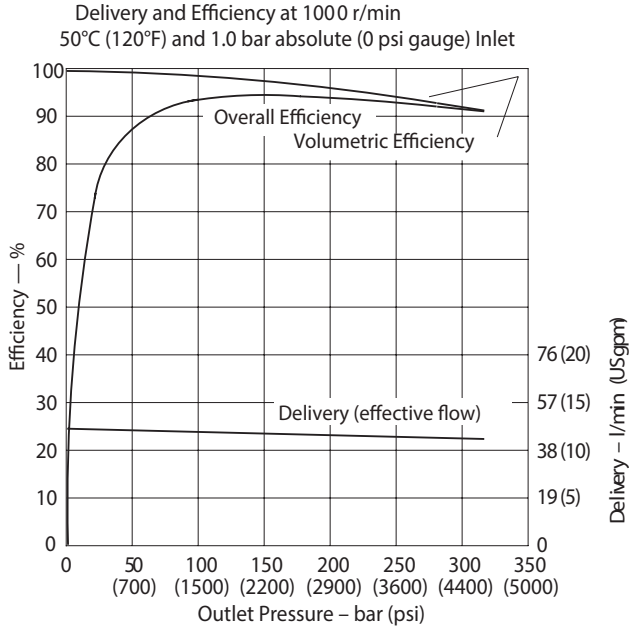

# Performance

Higher speed version (M)PVM045

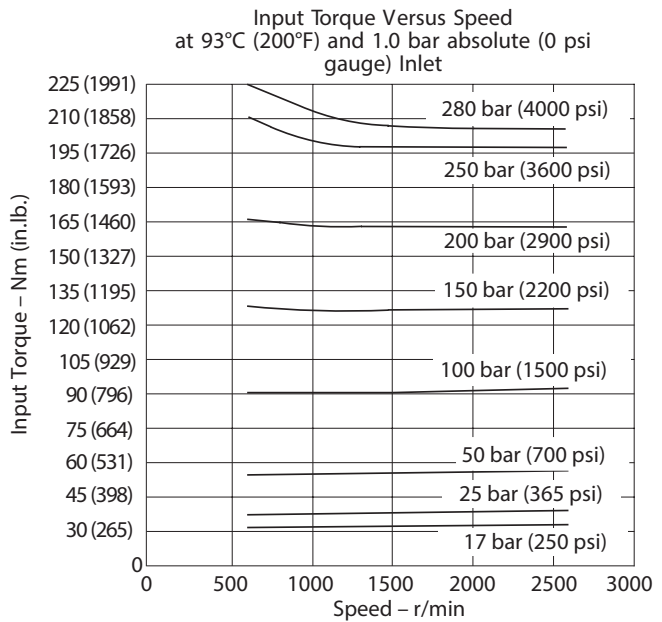
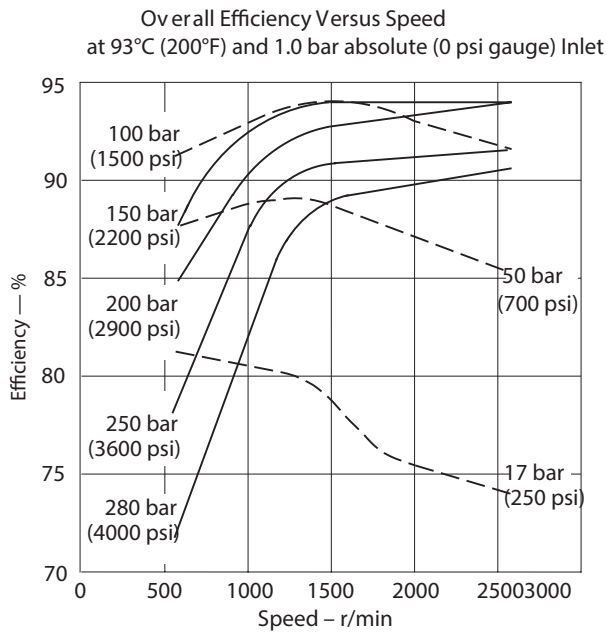
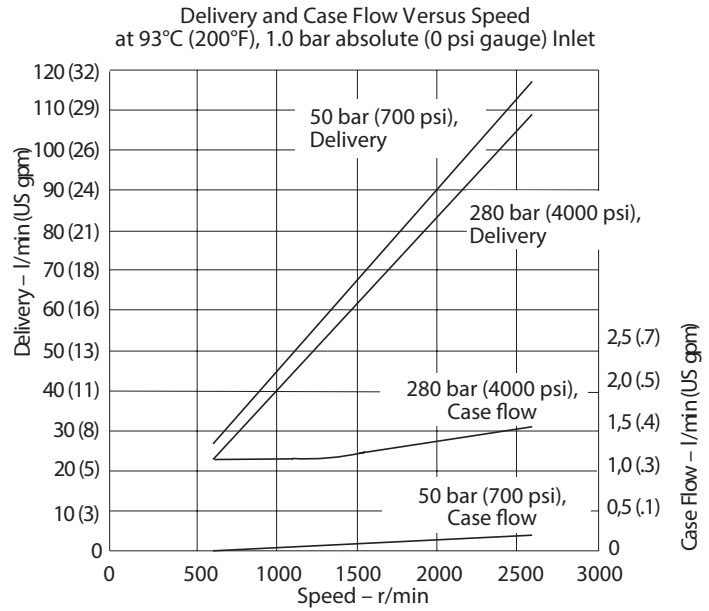
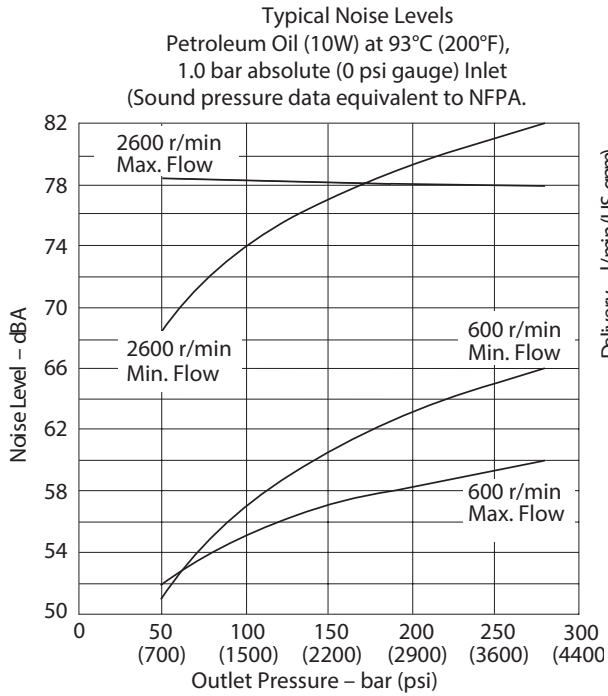



# Performance

Higher speed version (M)PVM045

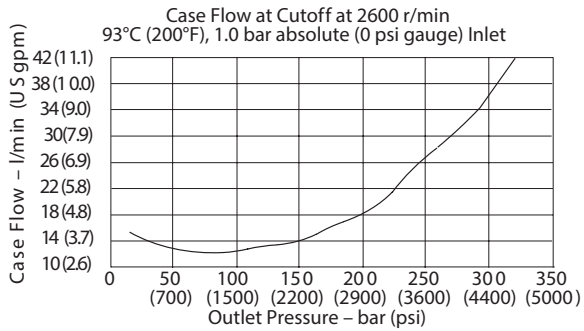
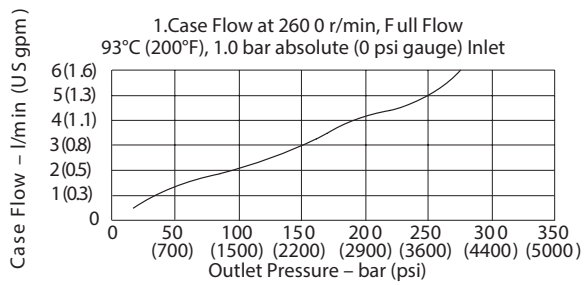
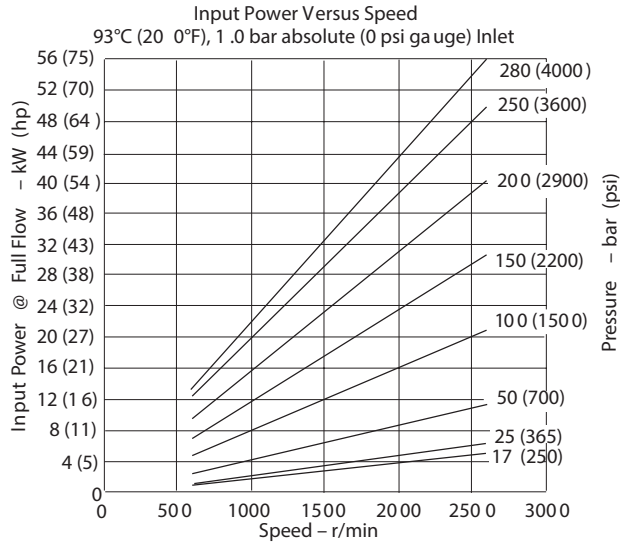

# Performance

Quiet version, optimized for 1000-1800 rpm (E) PVM050

Typical Noise Levels at 1800 and 1200 r/min with Petroleum Oil (10W) at 50°C (120°F) and 1.0 bar absolute (0 psi gauge) Inlet

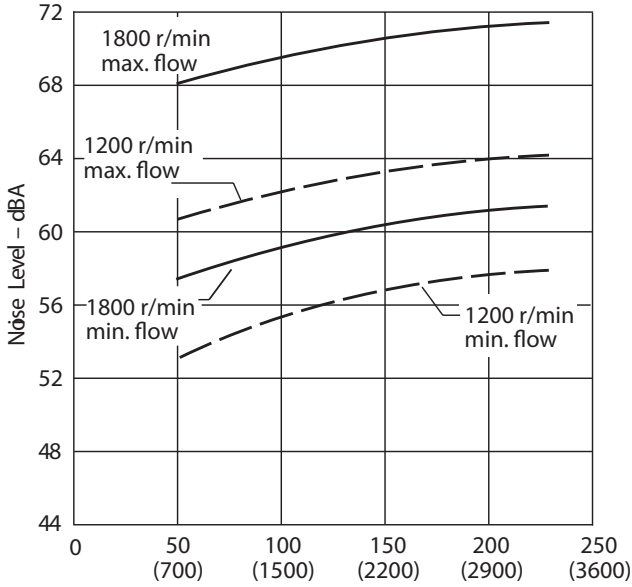

Delivery and Efficiency at 1800 r/min, 50°C (120°F), and 1.0 bar absolute (0 psi gauge) Inlet

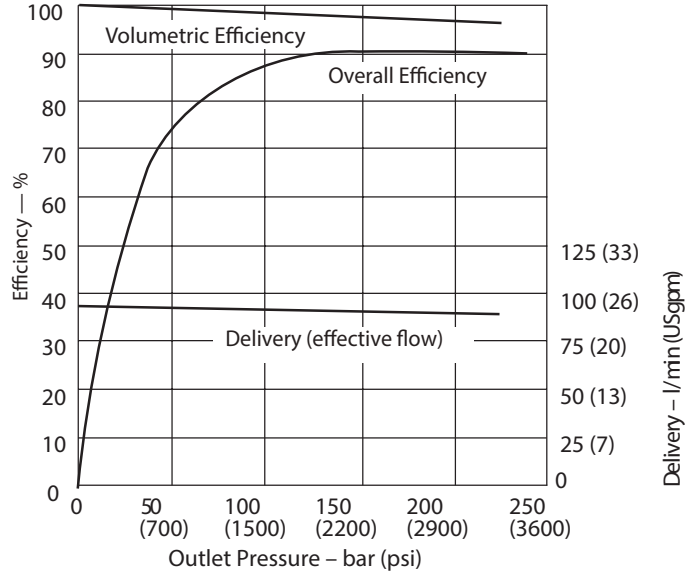

Typical Noise Levels at 1500 and 1000 r/min with Petroleum Oil (10W) at 50°C (120°F) and 1.0 bar absolute (0 psi gauge) Inlet

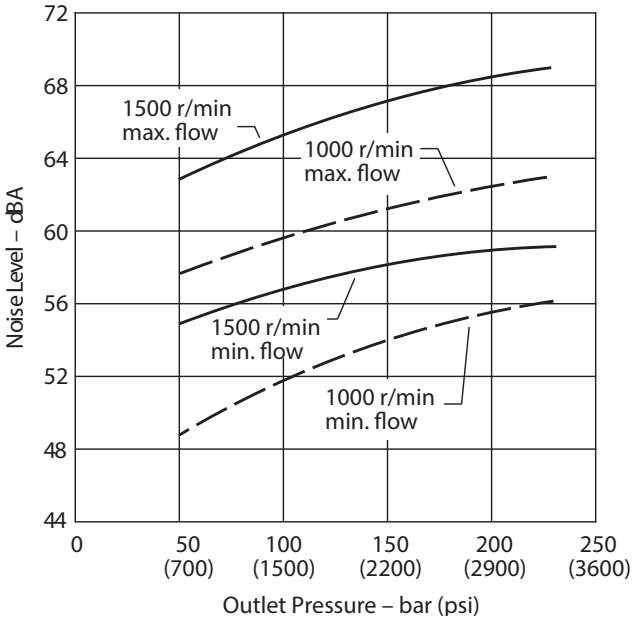

Input Torque and Power at 1800 r/min, 50°C (120°F), and 1.0 bar absolute (0 psi gauge) Inlet

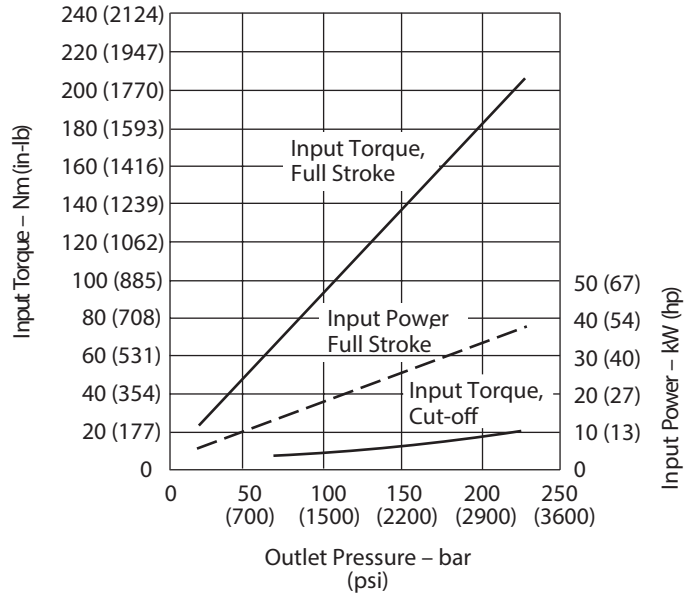

# Performance

Quiet version, optimized for 1000-1800 rpm (E) PVM050

Delivery and Efficiency at 1500 r/min, 50°C (120°F), and 1.0 bar absolute (0 psi gauge) Inlet

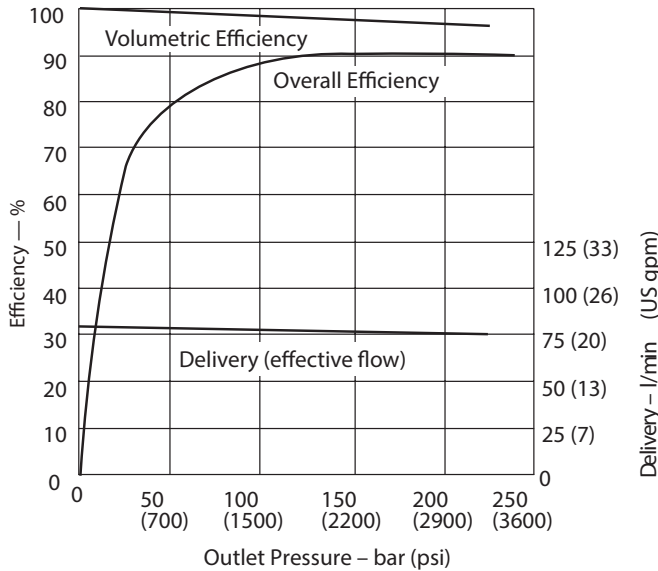

Delivery and Efficiency at 1200 r/min, 50°C (120°F), and 1.0 bar absolute (0 psi gauge) Inlet

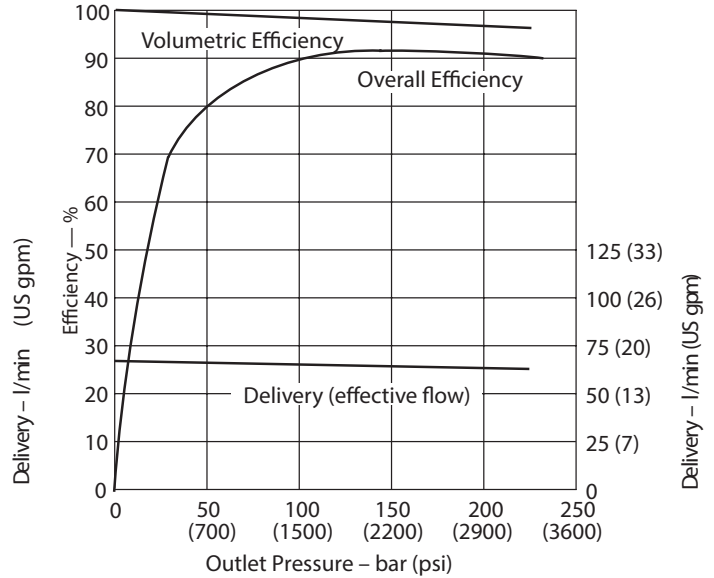

Input Torque and Power at 1500 r/min, 50°C (120°F), and 1.0 bar absolute (0 psi gauge) Inlet

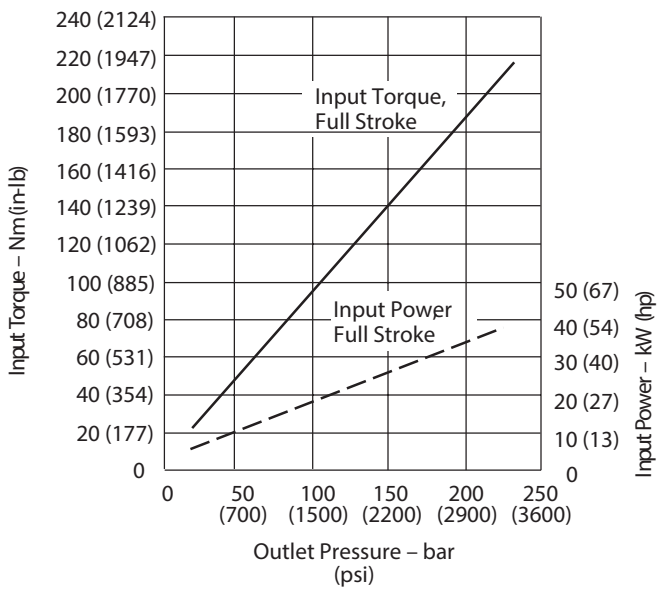

Input Torque and Power at 1200 r/min, 50°C (120°F), and 1.0 bar absolute (0 psi gauge) Inlet

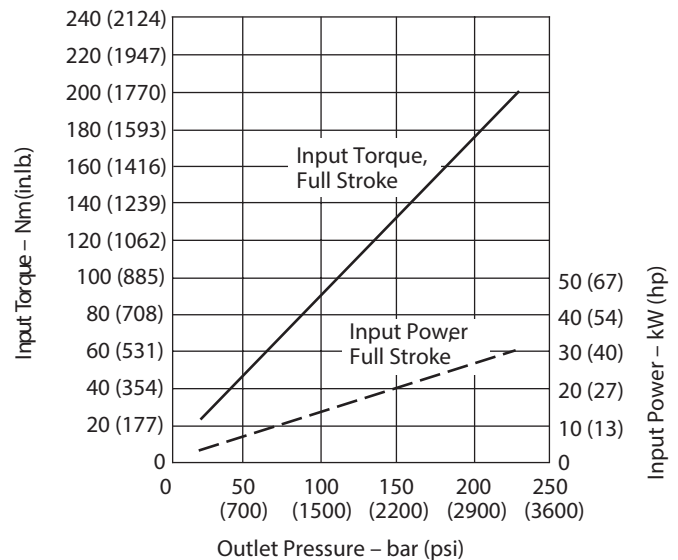

# Performance

Quiet version, optimized for 1000-1800 rpm (E) PVM050

Delivery and Efficiency at 1000 r/min, 50°C (120°F), and 1.0 bar absolute (0 psi gauge) Inlet

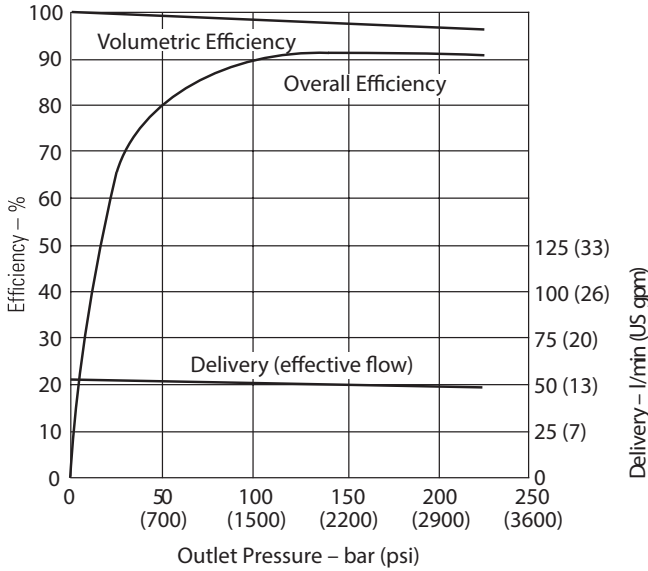

Case Flow versus Outlet Pressure at 1800 r/min, Full Flow, 50°C (120°F), and 1.0 bar absolute (0 psi gauge) Inlet

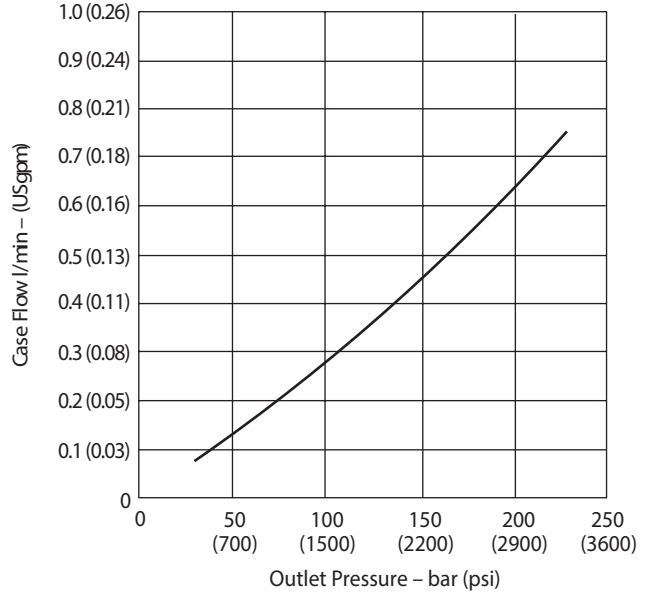

Input Torque and Power at 1000 r/min, 50°C (120°F), and 1.0 bar absolute (0 psi gauge) Inlet

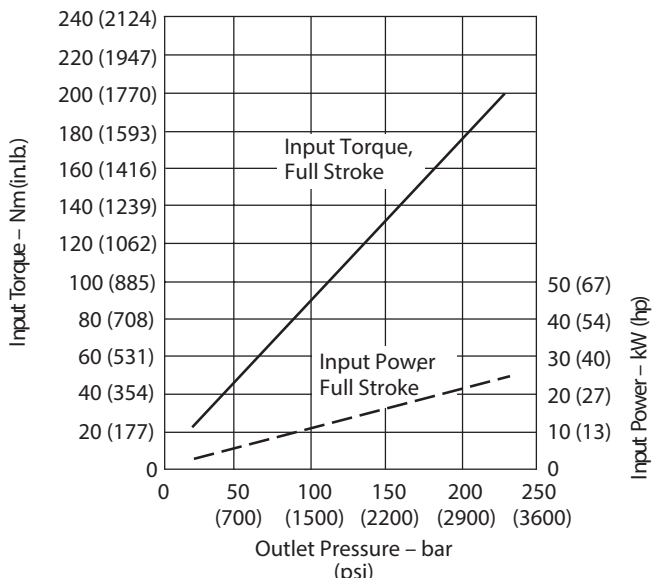

Case Flow versus Outlet Pressure at Cutoff, 1800 r/min, 50°C (120°F), and 1.0 bar absolute (0 psi gauge) Inlet

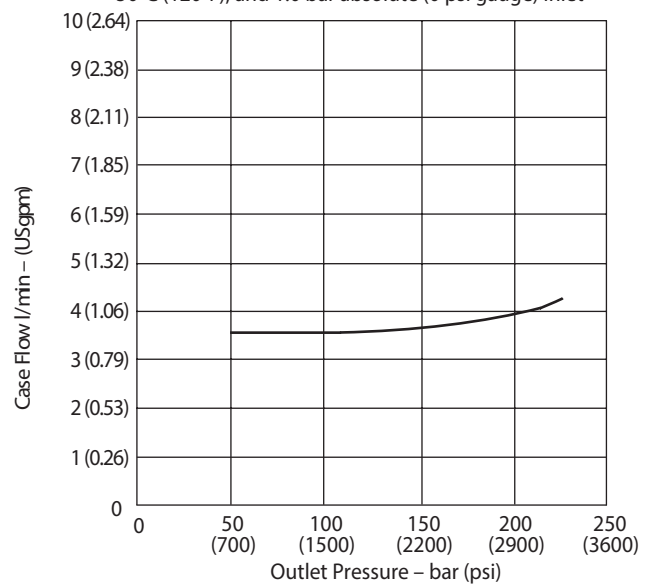

# Performance

Higher speed version (M)PVM050

Typical Noise Levels at 2600 & 600 r/min with Petroleum Oil (10W) at 93°C (200°F) and 1.0 bar absolute (0 psi gauge) inlet

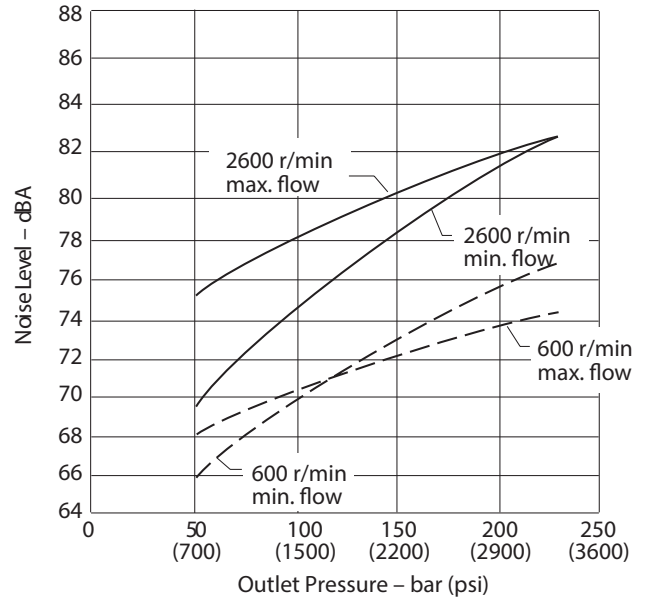

Sound pressure data equivalent to NFPA.

Overall Efficiency versus Speed at 93°C (200°F) and 1.0 bar absolute (0 psi gauge) inlet

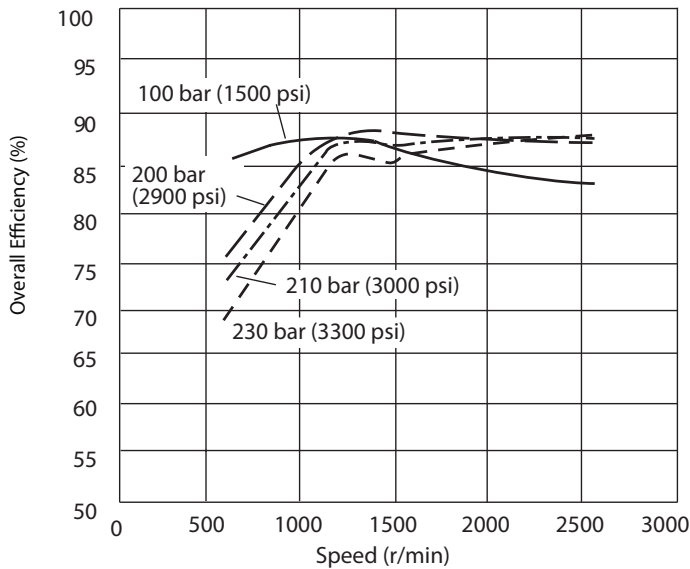

Delivery and Case Flow versus Speed at 93°C (200°F), Full Flow and 1.0 bar absolute (0 psi gauge) inlet

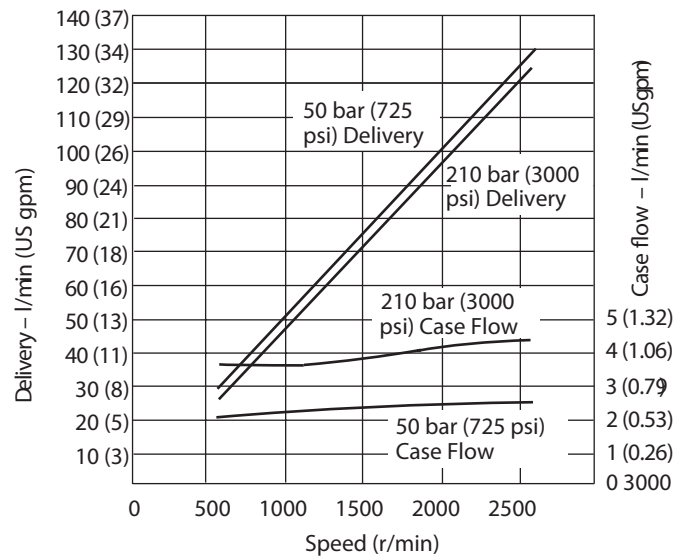

# Performance

Higher speed version (M)PVM050

Input Torque versus Speed at 93°C (200°F), Full Flow and 1.0 bar absolute (0 psi gauge) Inlet

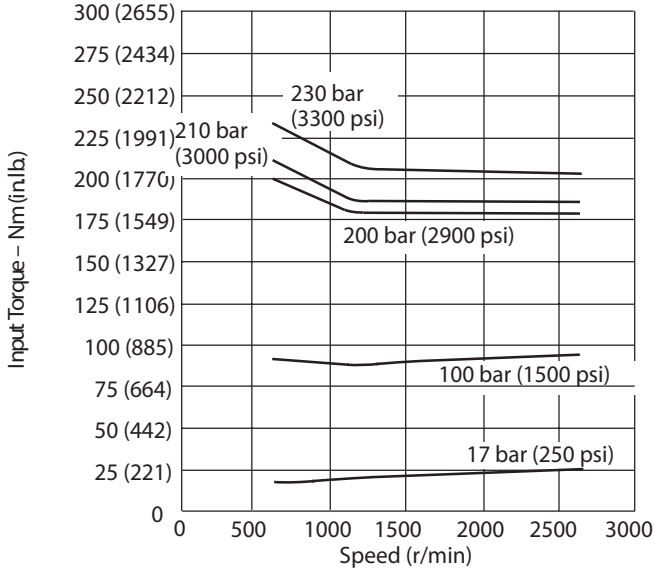

Input Power versus Speed at 93°C (200°F), Full Flow and 1.0 bar absolute (0 psi gauge) Inlet

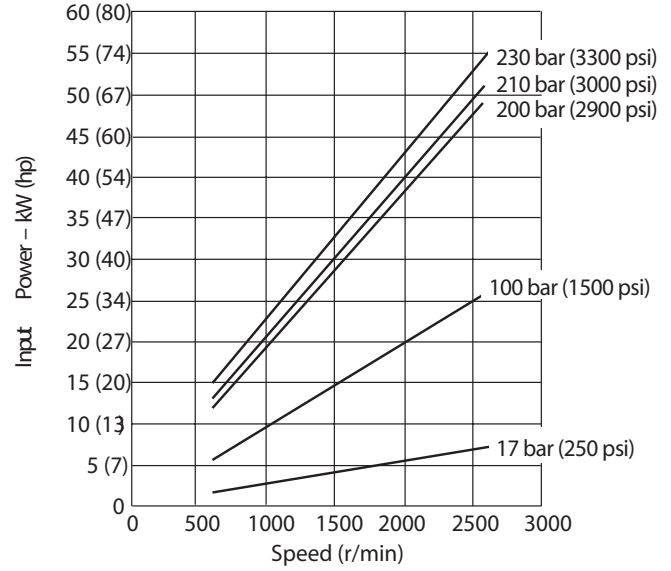

Input Torque and Case Flow versus Speed at 93°C (200°F), Load Sense Standby and 1.0 bar absolute (0 psi gauge) Inlet

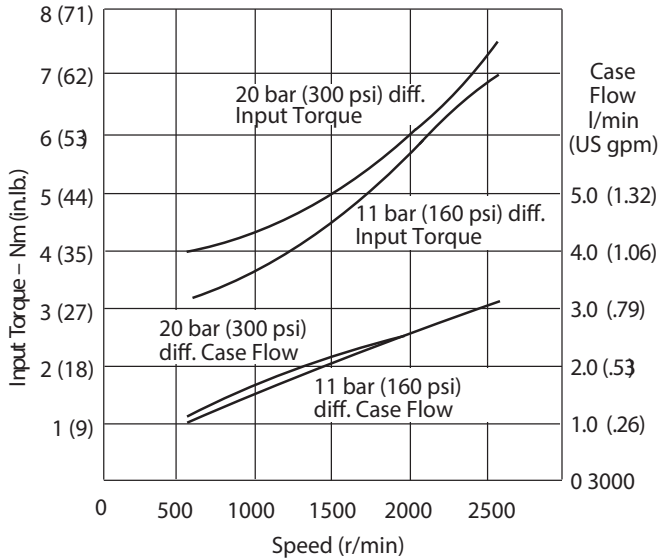

Input Torque and Case Flow versus Speed at 93°C (200°F), Pressure Limit Cut-off and 1.0 bar absolute (0 psi gauge) Inlet

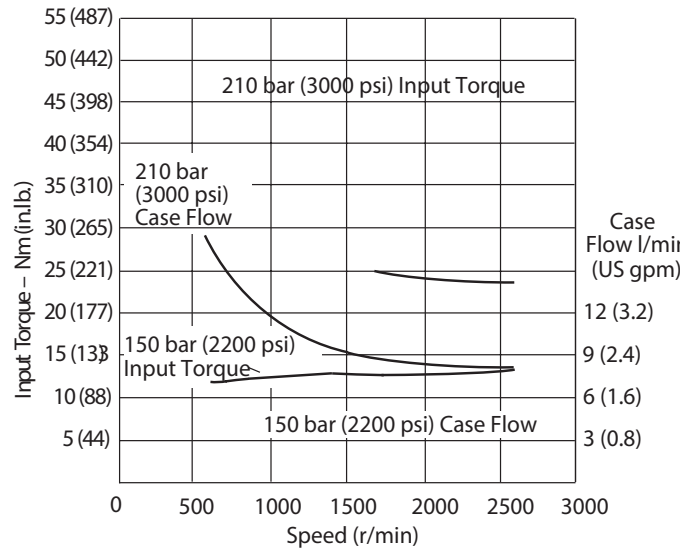

# Performance

Quiet version, optimized for 1000-1800 rpm (E) PVM057

Typical Noise Levels at 1800 and 1200 r/min with Petroleum Oil (10W) at 50°C (120°F) and 1.0 bar absolute (0 psi gauge) Inlet

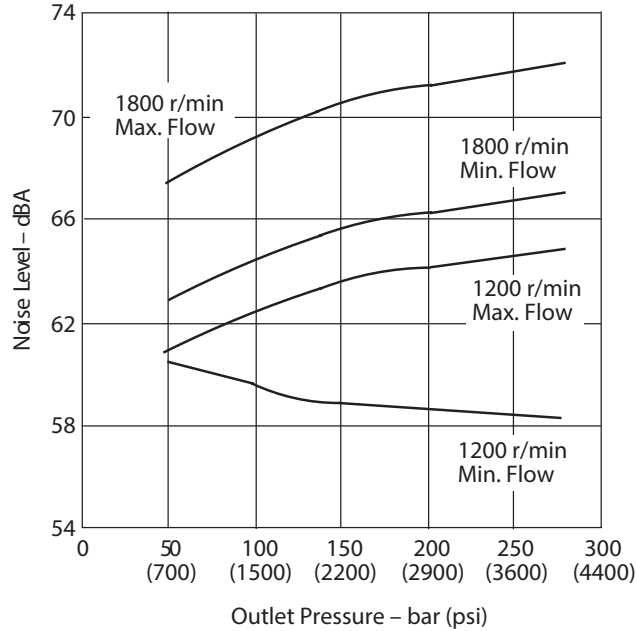

(Sound pressure data equivalent to NFPA.)

Delivery and Efficiency at 1800 r/min 50°C (120°F) and 1.0 bar absolute (0 psi gauge) Inlet

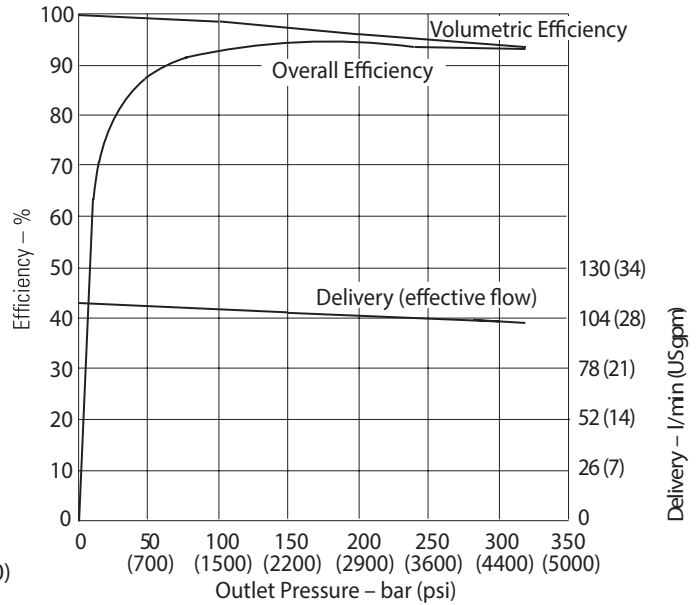

Typical Noise Levels at 1500 and 1000 r/min with Petroleum Oil (10W) at 50°C (120°F) and 1.0 bar absolute (0 psi gauge) Inlet

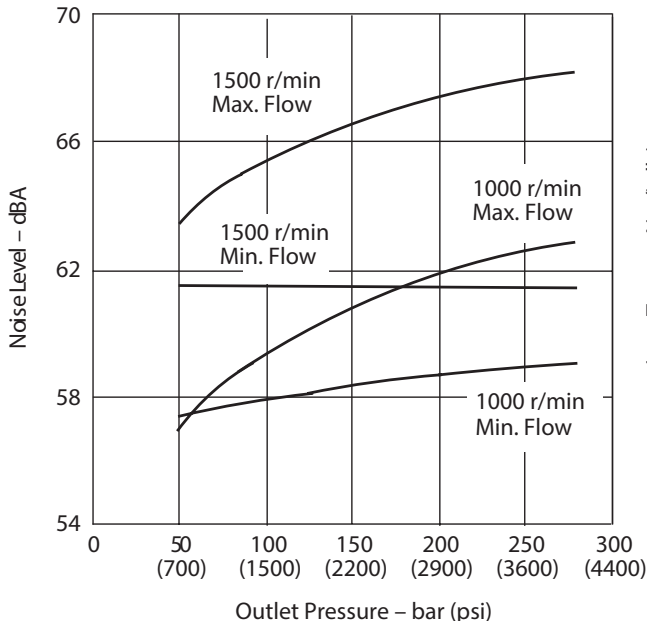

Input Torque and Power at 1800 r/min 50°C (120°F) and 1.0 bar absolute (0 psi gauge) Inlet

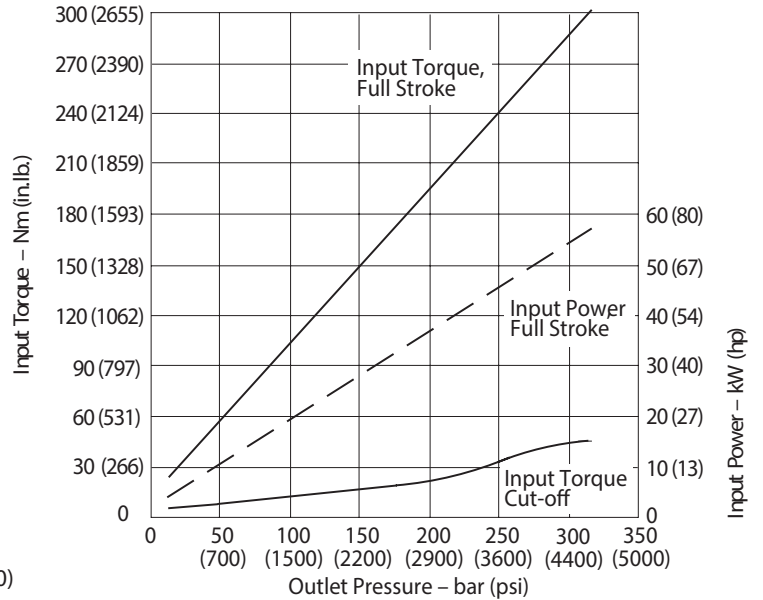

# Performance

Quiet version, optimized for 1000-1800 rpm (E) PVM057

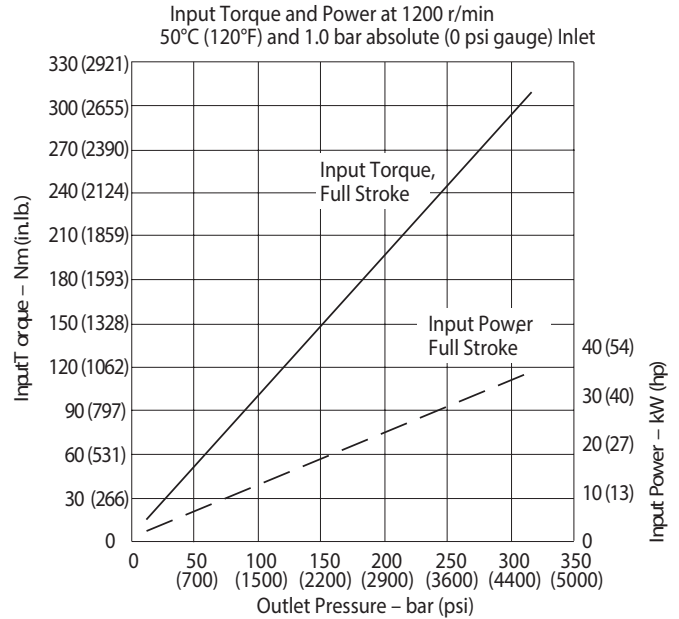
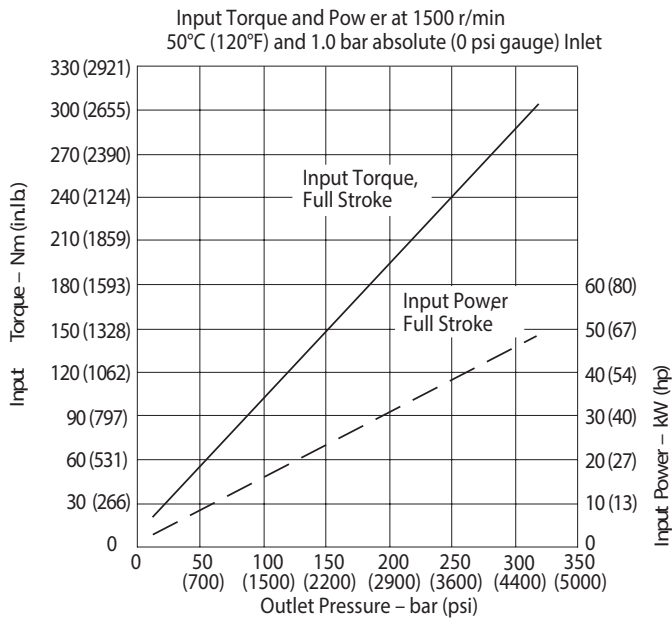
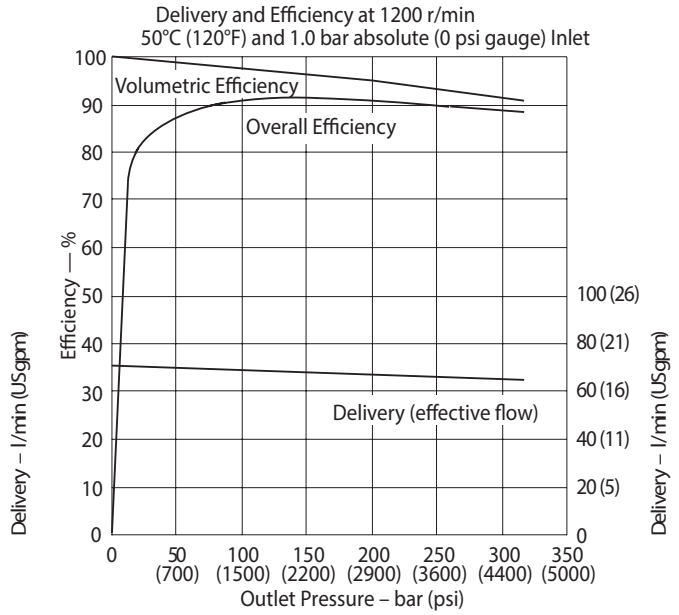
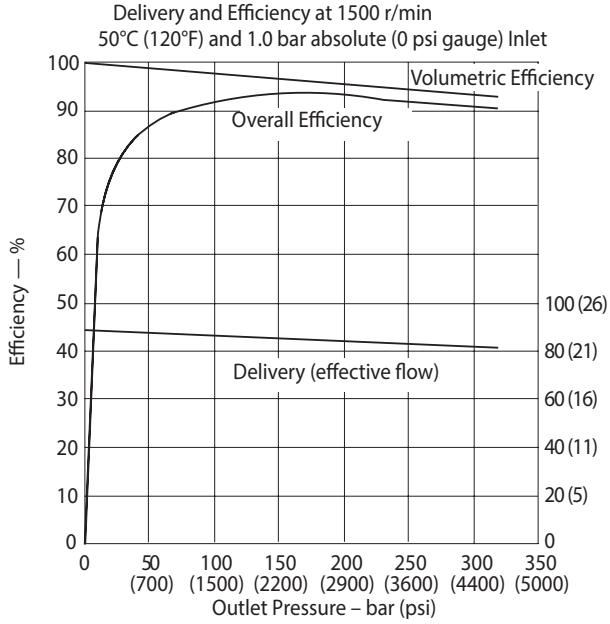



# Performance

Quiet version, optimized for 1000-1800 rpm (E) PVM057

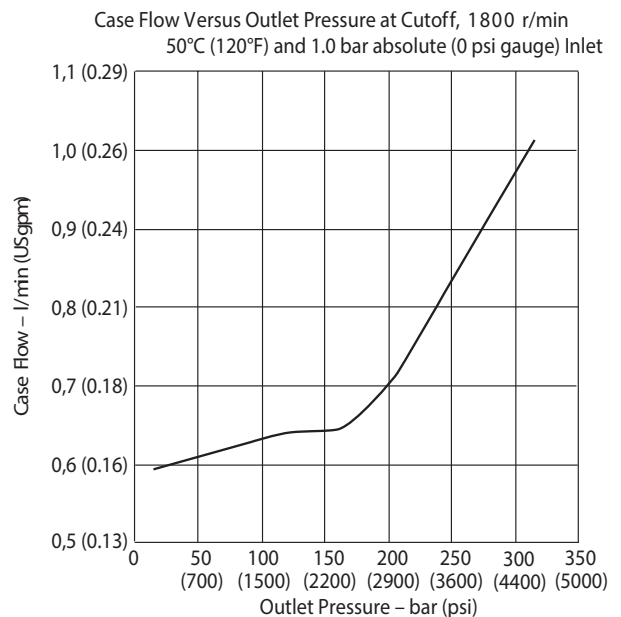
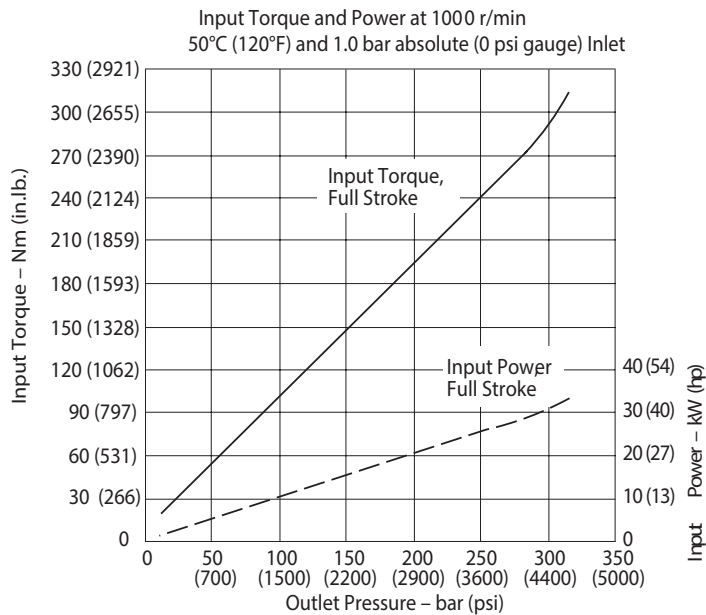
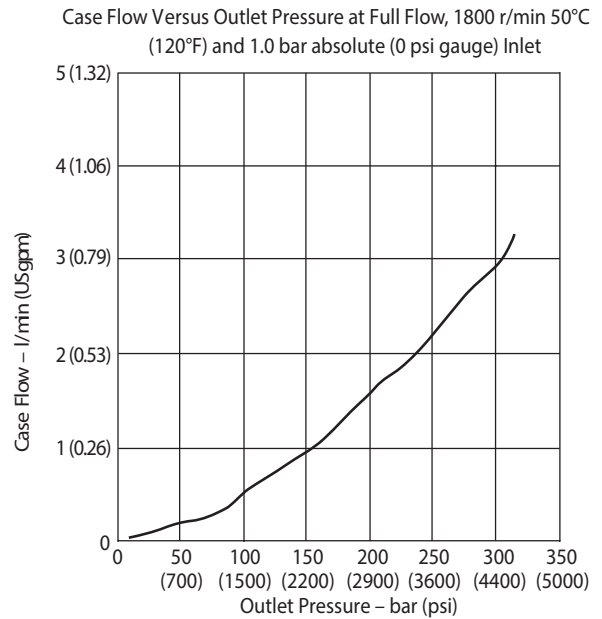
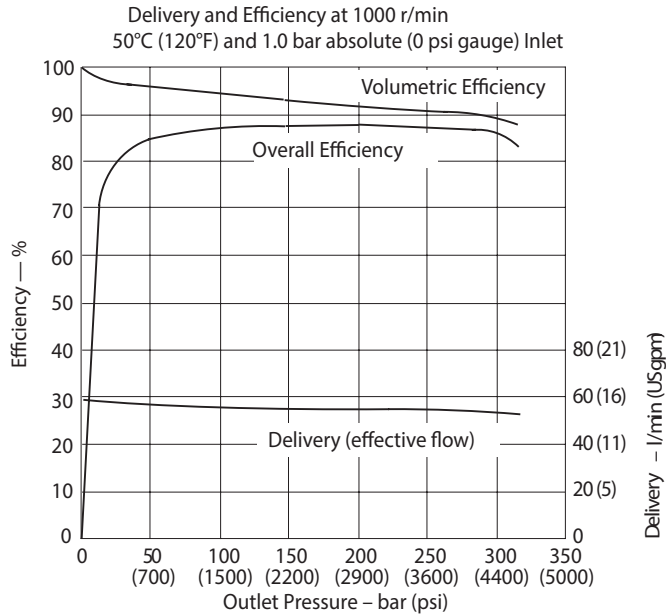

# Performance

Higher speed version (M)PVM057

Typical Noise Levels  
Petroleum Oil (10W) at 93°C (200°F),  
1.0 bar absolute (0 psi gauge) Inlet

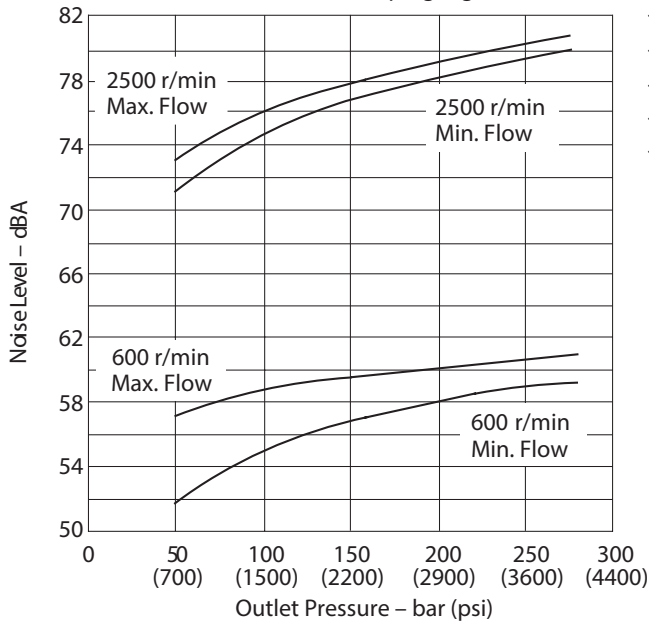

(Sound pressure data equivalent to NFPA)

Delivery and Case Flow Versus Speed  
@ 93°C (200°F), full flow and 1.0 bar absolute (0 psi gauge) inlet

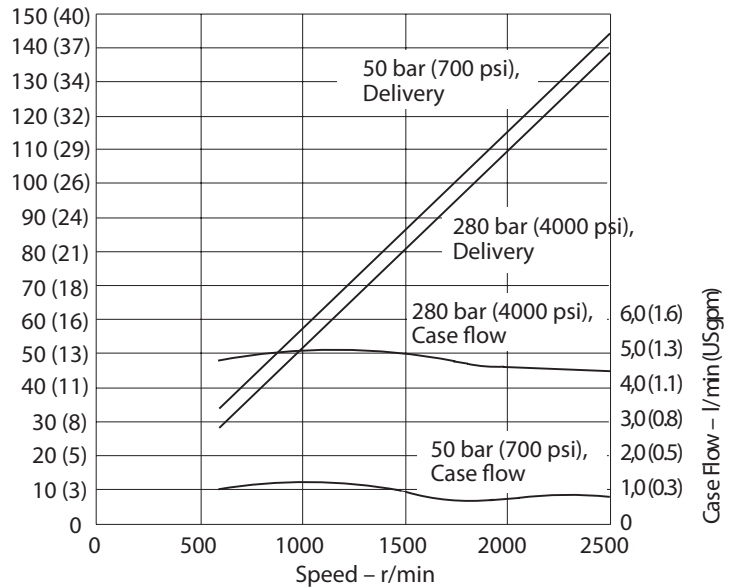

Overall Efficiency Versus Speed  
at 93°C (200°F) and 1.0 bar absolute (0 psi gauge) Inlet

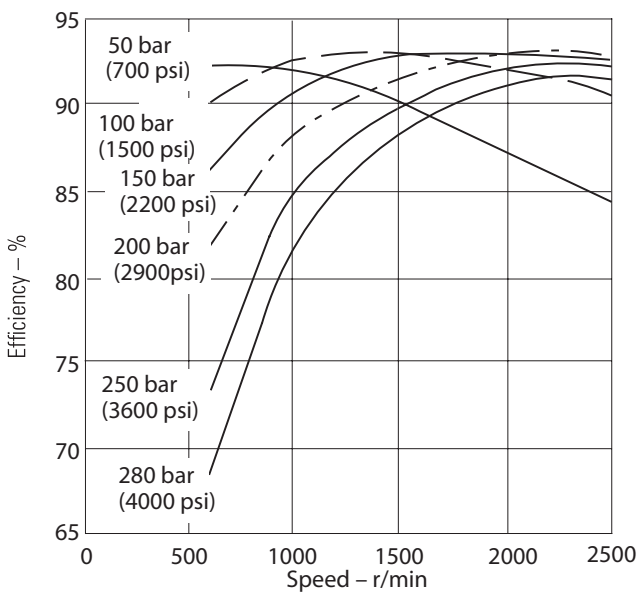

Input Torque Versus Speed  
@ 93°C (200°F), full flow and 1.0 bar absolute (0 psi gauge) inlet

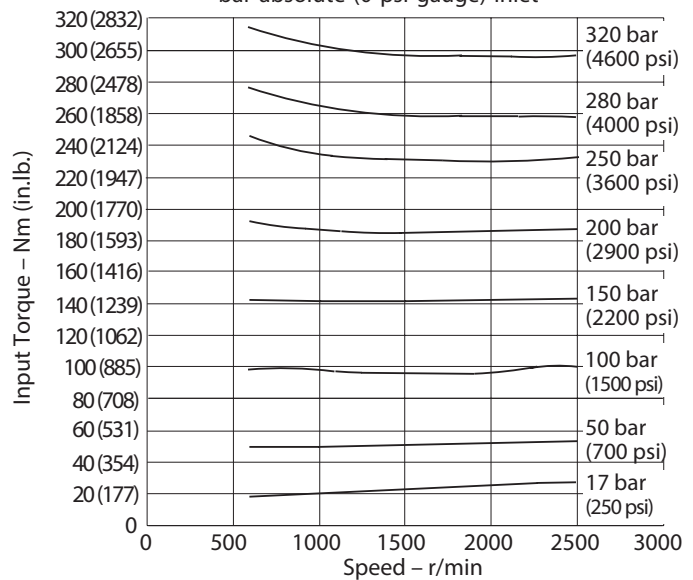

# Performance

Higher speed version (M)PVM057

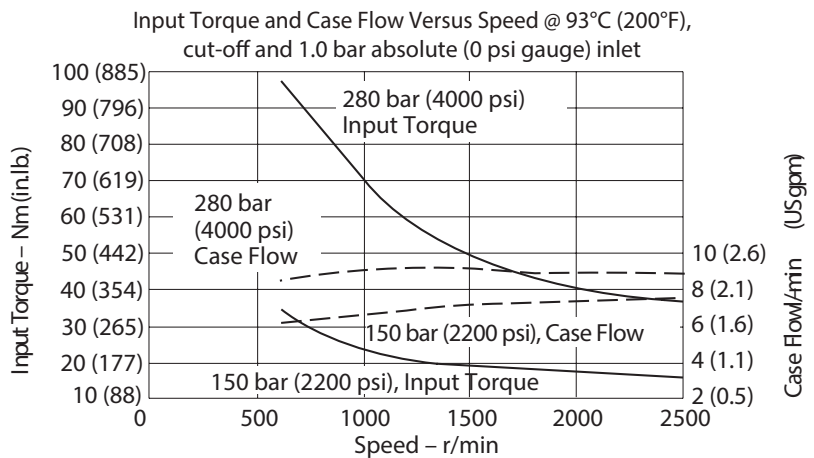
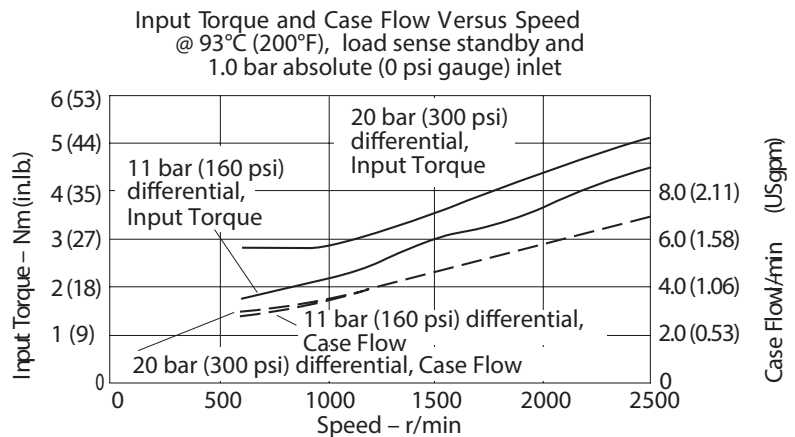
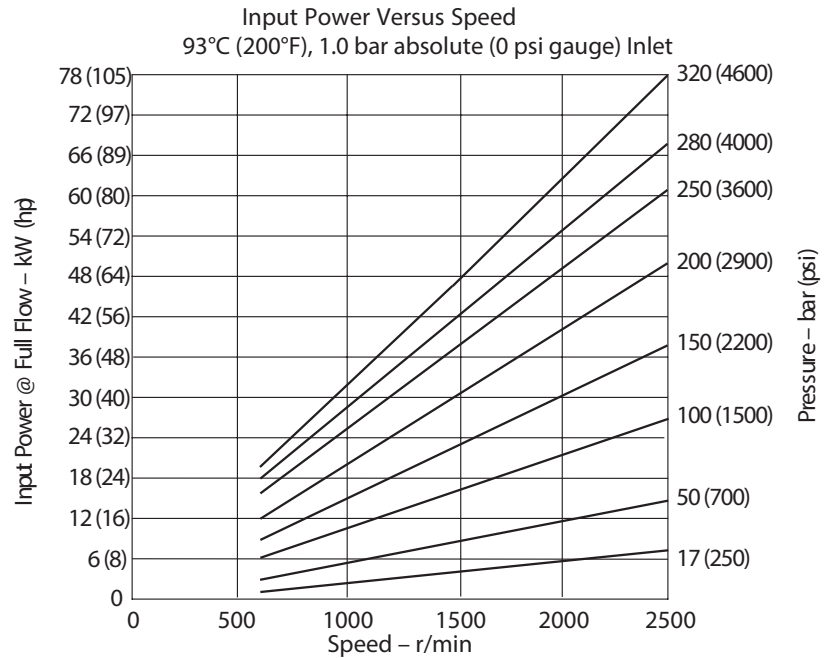

# Performance

Quiet version, optimized for 1000-1800 rpm (E) PVM063

Typical Noise Levels at 1800 and 1200 r/min. with Petroleum Oil (10W) at 50°C (120°F) and 1.0 bar absolute (0 psi gauge) Inlet

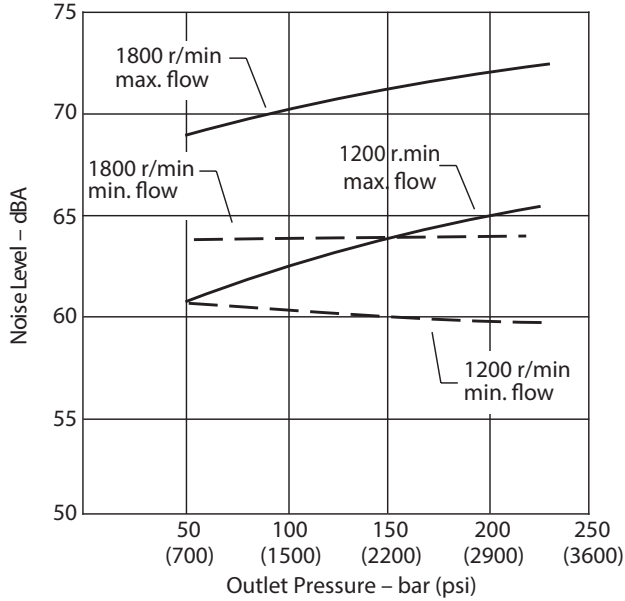

Delivery and Efficiency at 1800 r/min, 50°C (120°F), and 1.0 bar absolute (0 psi gauge) Inlet

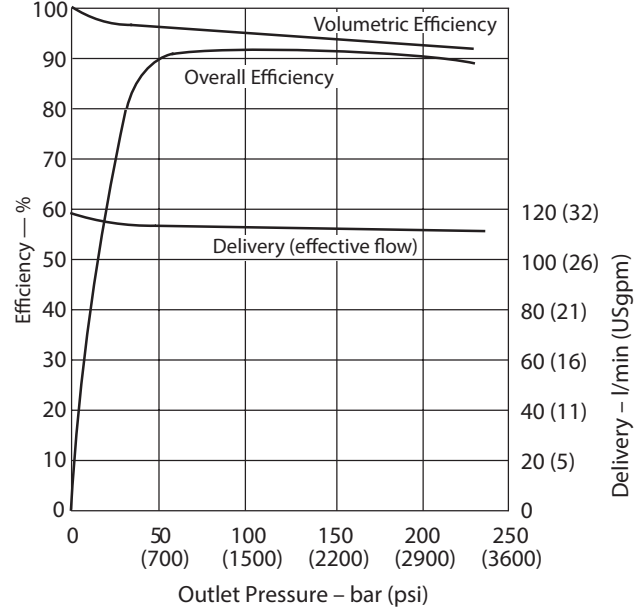

Typical Noise Levels at 1500 and 1000 r/min. with Petroleum Oil (10W) at 50°C (120°F) and 1.0 bar absolute (0 psi gauge) Inlet

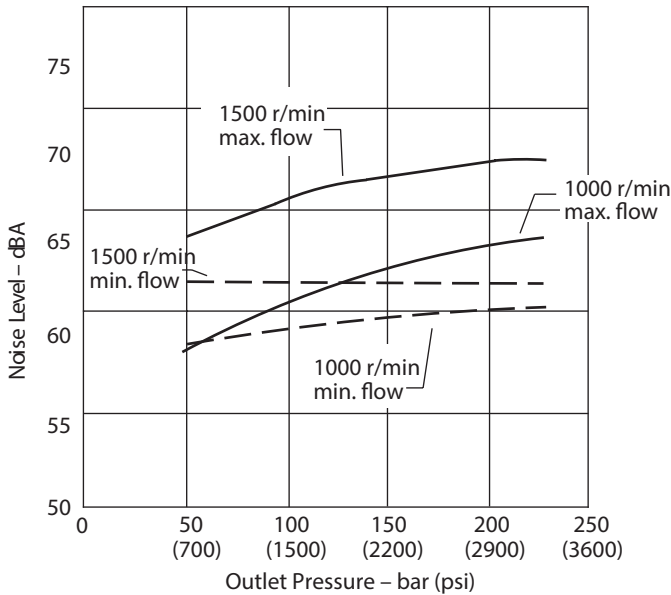

Input Torque and Power at 1800 r/min, 50°C (120°F), and 1.0 bar absolute (0 psi gauge) Inlet

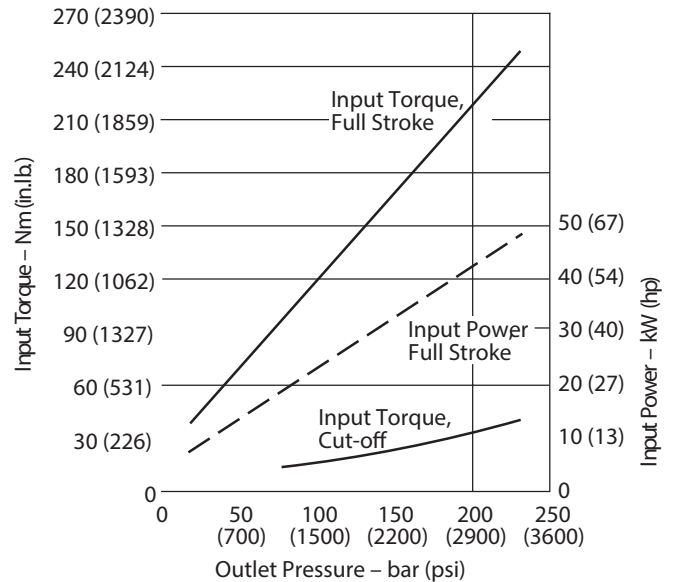

Sound pressure data equivalent to NFPA.

# Performance

Quiet version, optimized for 1000-1800 rpm (E) PVM063

Delivery and Efficiency at 1500 r/min, 50C (120F), and 1.0 bar absolute (0 psi gauge) Inlet

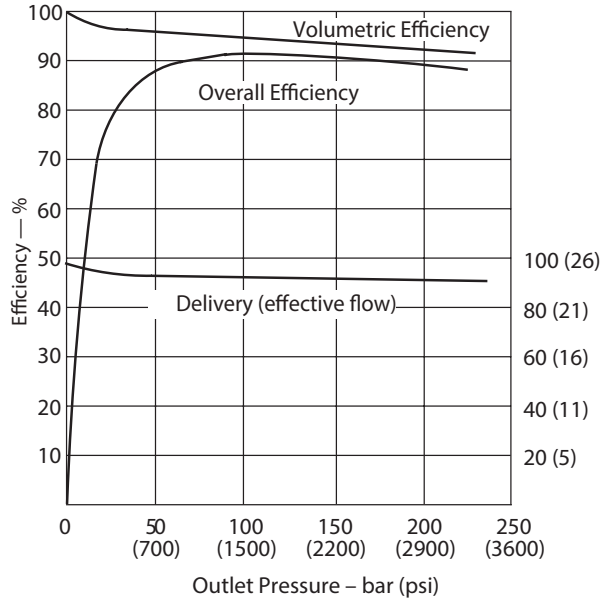

Delivery and Efficiency at 1200 r/min, 50C (120F), and 1.0 bar absolute (0 psi gauge) Inlet

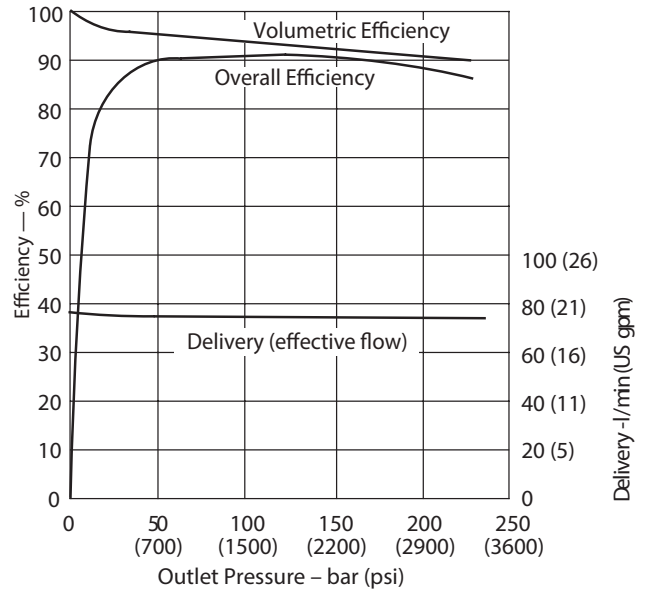

Input Torque and Power at 1500 r/min, 50C (120F), and 1.0 bar absolute (0 psi gauge) Inlet

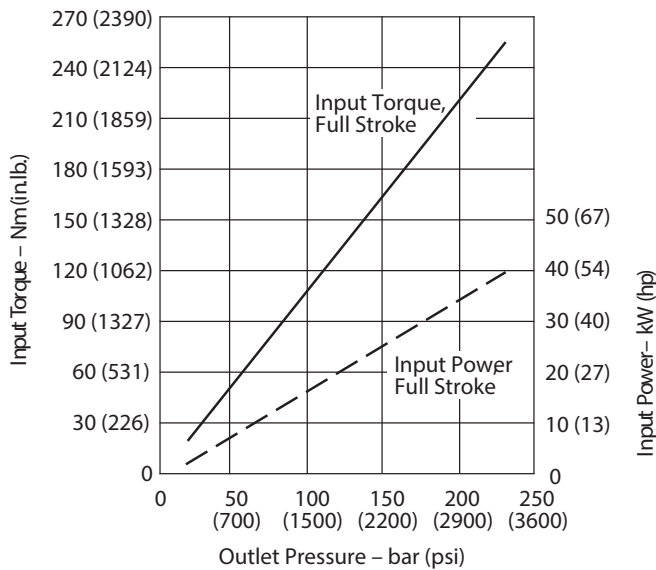

Input Torque and Power at 1200 r/min, 50C (120F), and 1.0 bar absolute (0 psi gauge) Inlet

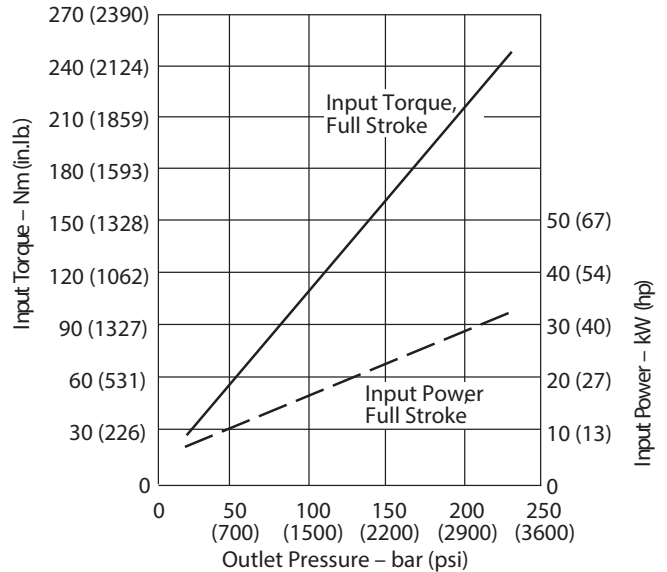

# Performance

Quiet version, optimized for 1000-1800 rpm (E) PVM063

Delivery and Efficiency at 1000 r/min, 50C (120F), and 1.0 bar absolute (0 psi gauge) Inlet

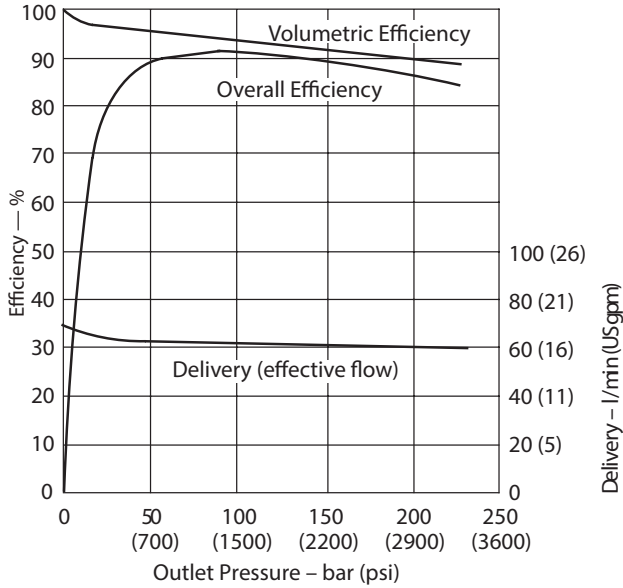

Case Flow versus Outlet Pressure at 1800 r/min, Full Flow, 50°C (120°F), and 1.0 bar absolute (0 psi gauge) Inlet

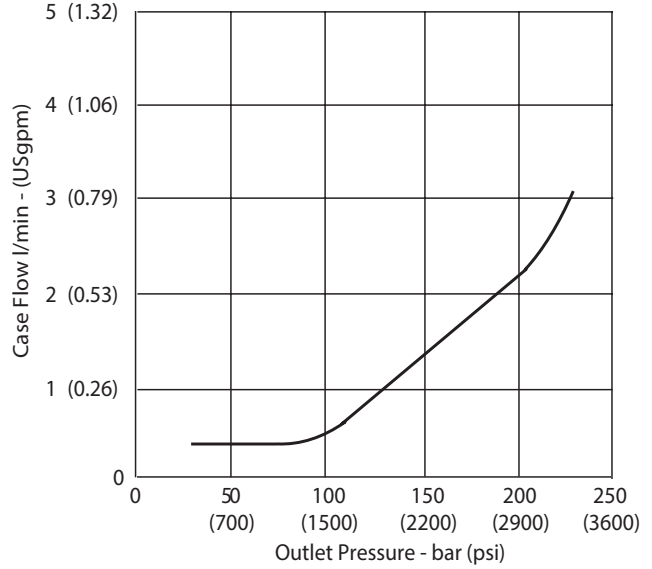

Input Torque and Power at 1000 r/min, 50C (120F), and 1.0 bar absolute (0 psi gauge) Inlet

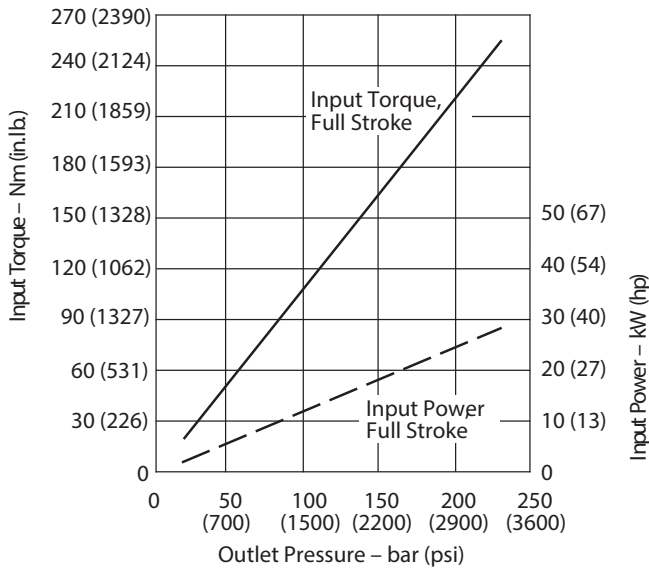

Case Flow versus Outlet Pressure at Cutoff, 1800 r/min, 50°C (120°F), and 1.0 bar absolute (0 psi gauge) Inlet

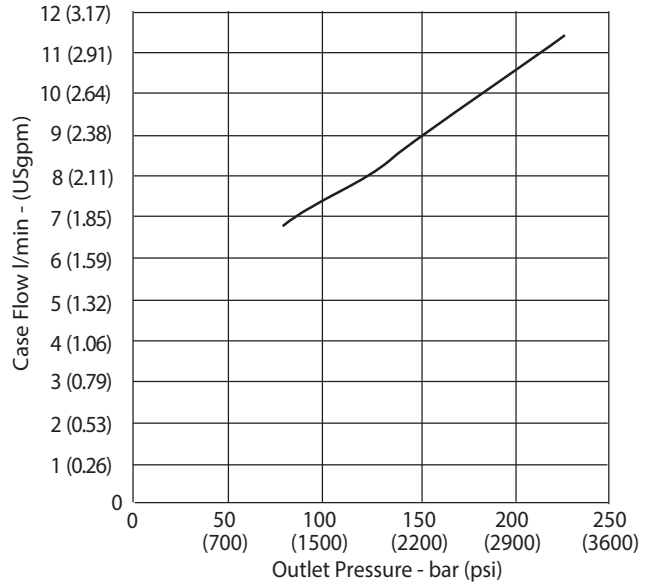

# Performance

Higher speed version (M)PVM063

Typical Noise Levels at 2500 & 600 r/min with Petroleum Oil (10W) at 93°C (200°F) and 1.0 bar absolute (0 psi gauge) Inlet

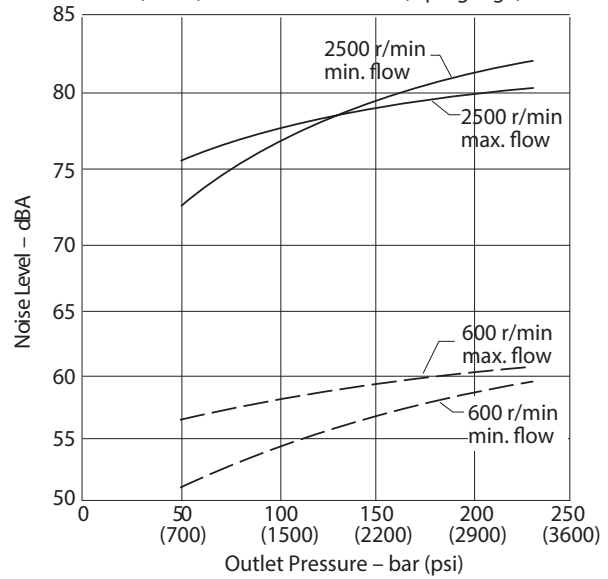

Sound pressure data equivalent to NFPA.

Overall Efficiency versus Speed at 93°C (200°F) and 1.0 bar absolute (0 psi gauge) inlet

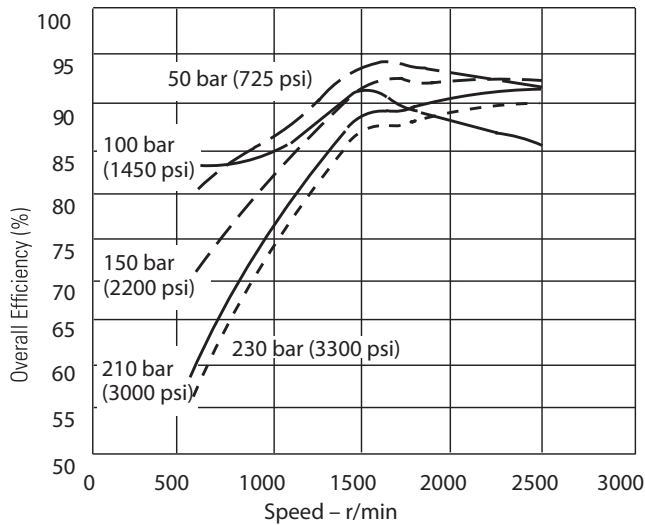

Delivery and Case Flow versus Speed at 93°C (200°F), Full Flow 1.0 bar absolute (0 psi gauge) Inlet

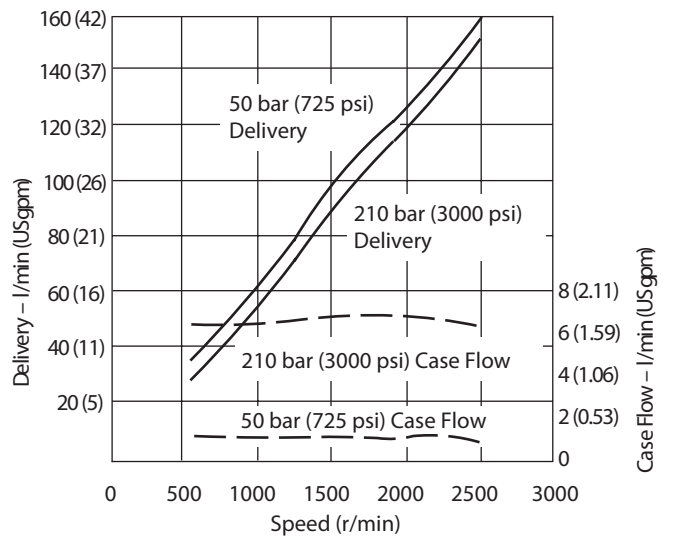

# Performance

Higher speed version (M)PVM063

Input Torque versus Speed at 93°C (200°F), Full Flow and 1.0 bar absolute (0 psi gauge) Inlet

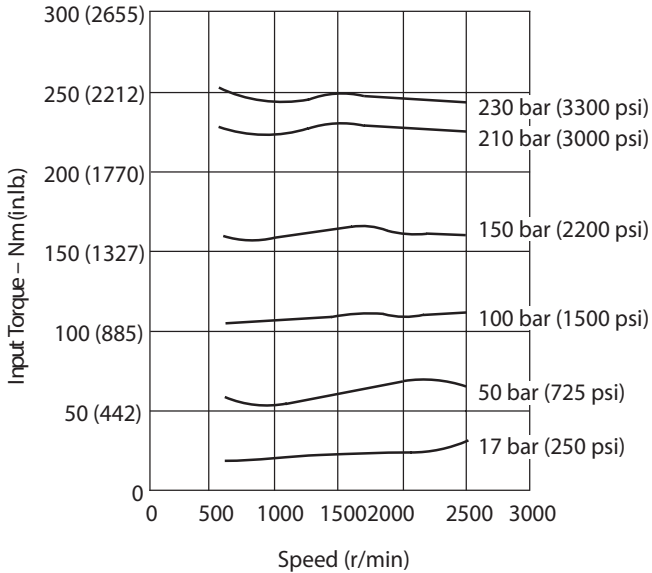

Input Power versus Speed at 93°C (200°F), Full Flow and 1.0 bar absolute (0 psi gauge) Inlet

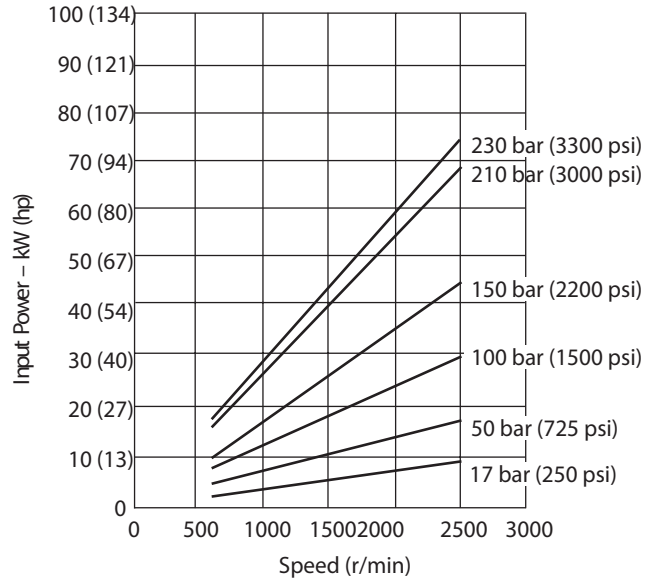

Input Torque and Case Flow versus Speed at 93°C (200°F), Load Sense Standby and 1.0 bar absolute (0 psi gauge) Inlet

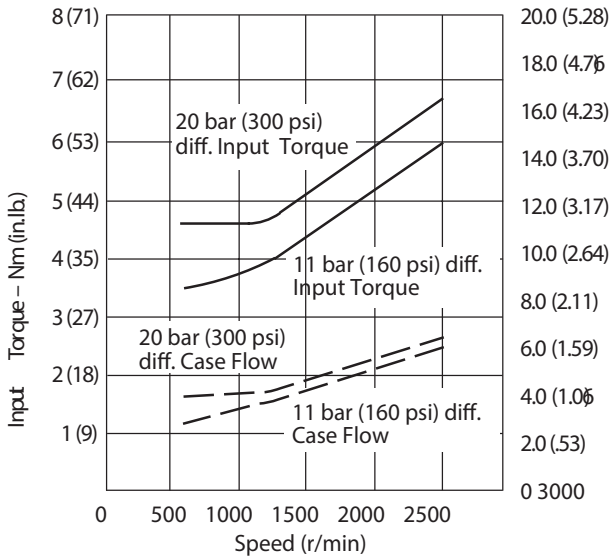

Input Torque and Case Flow versus Speed at 93°C (200°F), Pressure Limit Cut-off and 1.0 bar absolute (0 psi gauge) Inlet

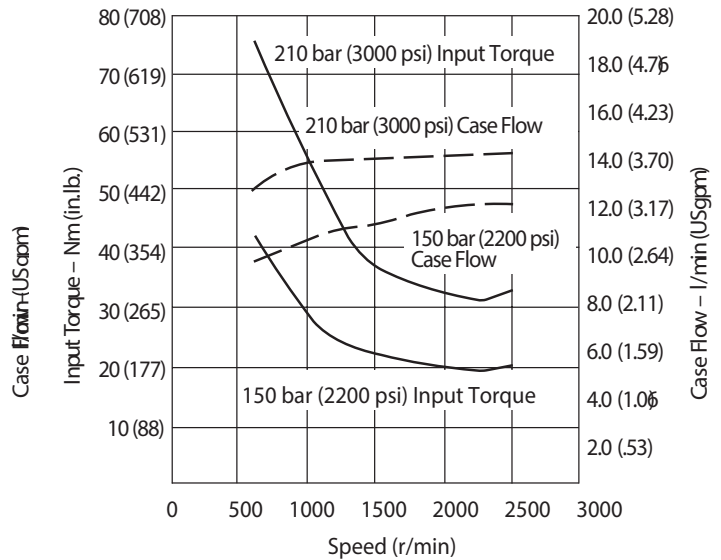



# Performance

Quiet version, optimized for 1000-1800 rpm (E) PVM074

Typical Noise Levels at 1800 and 1200 r/min with Petroleum Oil (10W) at 50°C (120°F) and 1.0 bar absolute (0 psi gauge) Inlet

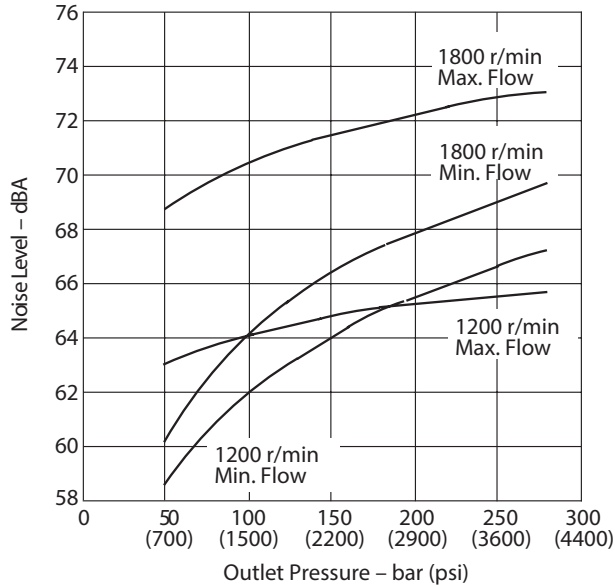

Sound pressure data equivalent to NFPA.

Delivery and Efficiency at 1800 r/min 50°C (120°F) and 1.0 bar absolute (0 psi gauge) Inlet

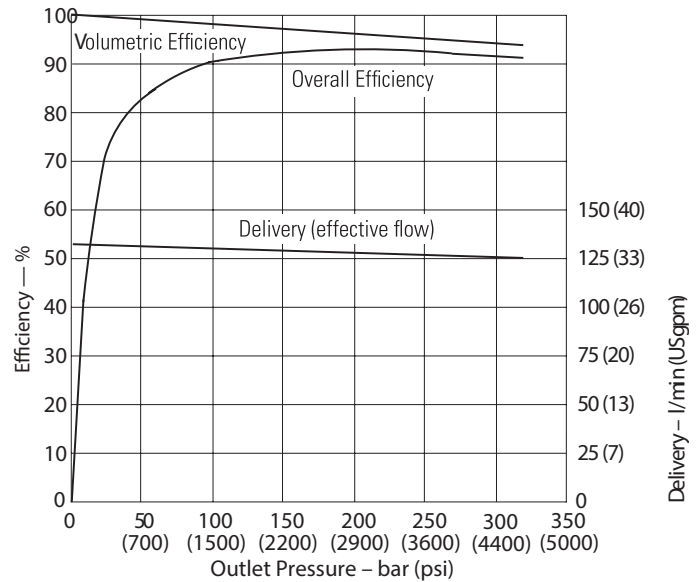

Typical Noise Levels at 1500 and 1000 r/min with Petroleum Oil (10W) at 50°C (120°F) and 1.0 bar absolute (0 psi gauge) Inlet

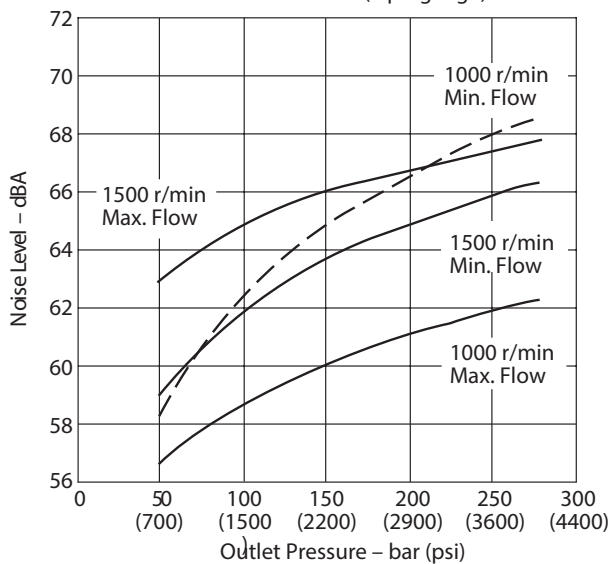

Input Torque and Power at 1800 r/min 50°C (120°F) and 1.0 bar absolute (0 psi gauge) Inlet

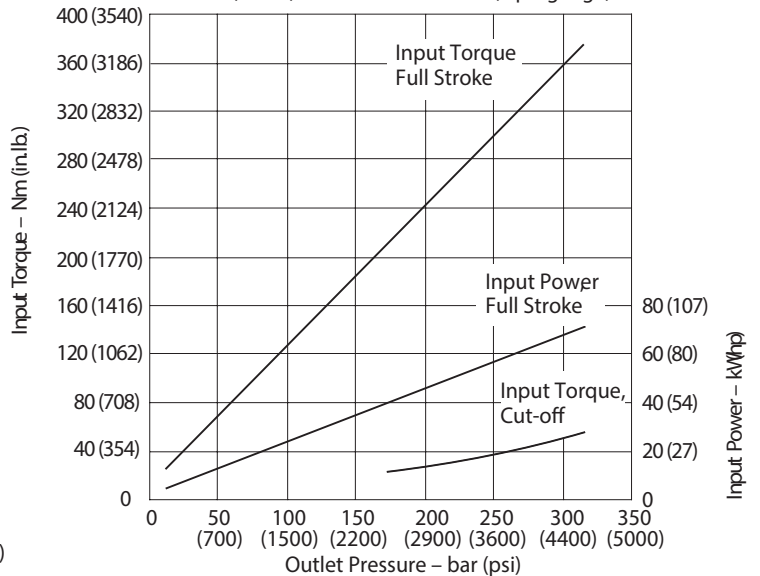

# Performance

Quiet version, optimized for 1000-1800 rpm (E) PVM074

Delivery and Efficiency at 1500 r/min  
50°C (120°F) and 1.0 bar absolute (0 psi gauge) Inlet

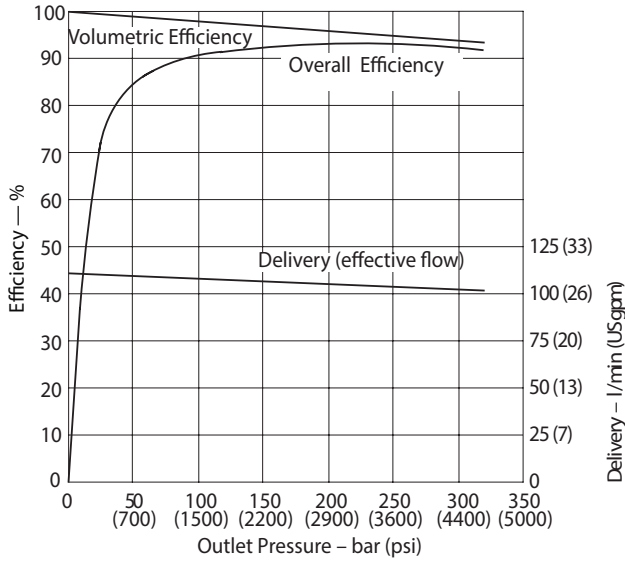

Delivery and Efficiency at 1200 r/min  
50°C (120°F) and 1.0 bar absolute (0 psi gauge) Inlet

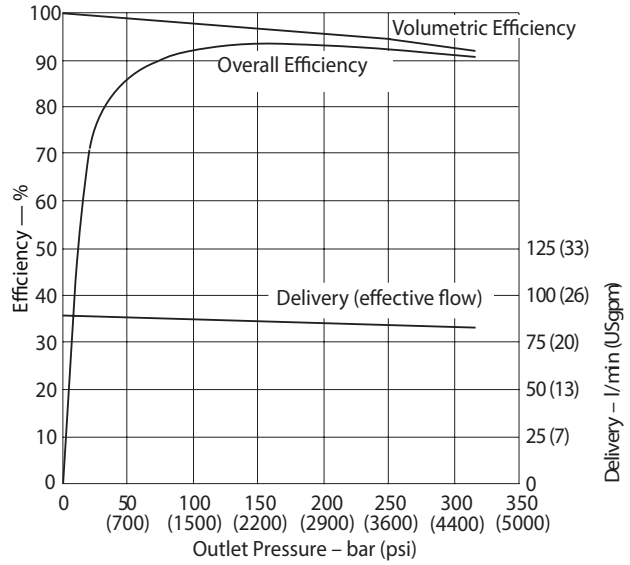

Input Torque and Power at 1500 r/min  
50°C (120°F) and 1.0 bar absolute (0 psi gauge) Inlet

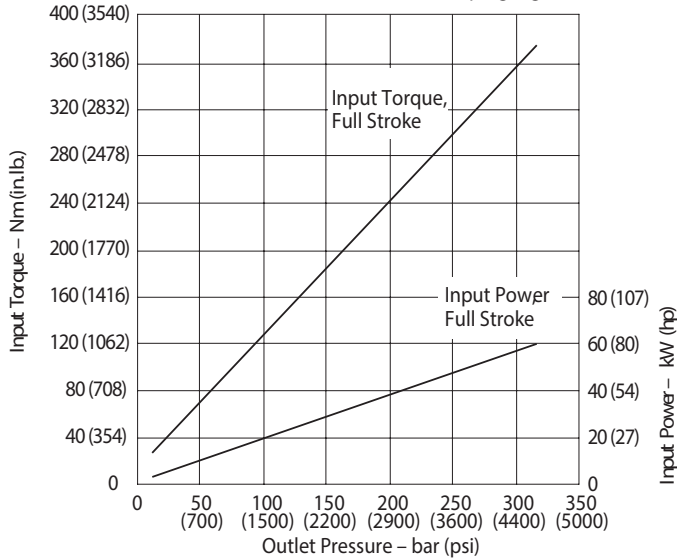

Input Torque and Power at 1200 r/min  
50°C (120°F) and 1.0 bar absolute (0 psi gauge) Inlet

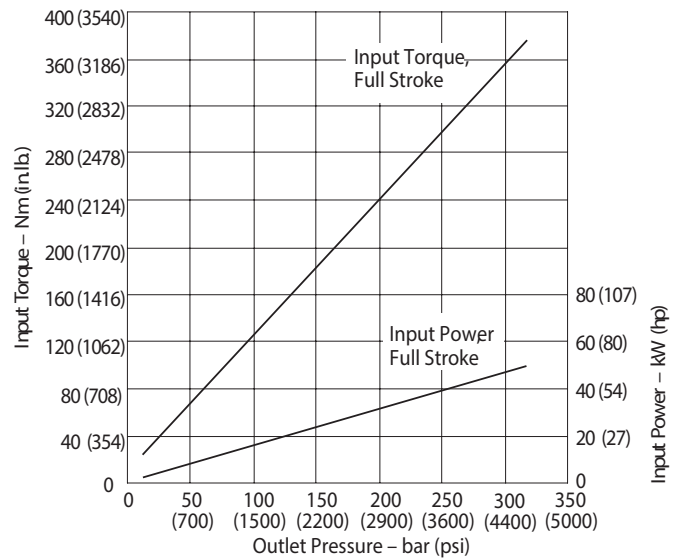

# Performance

Quiet version, optimized for 1000-1800 rpm (E) PVM074

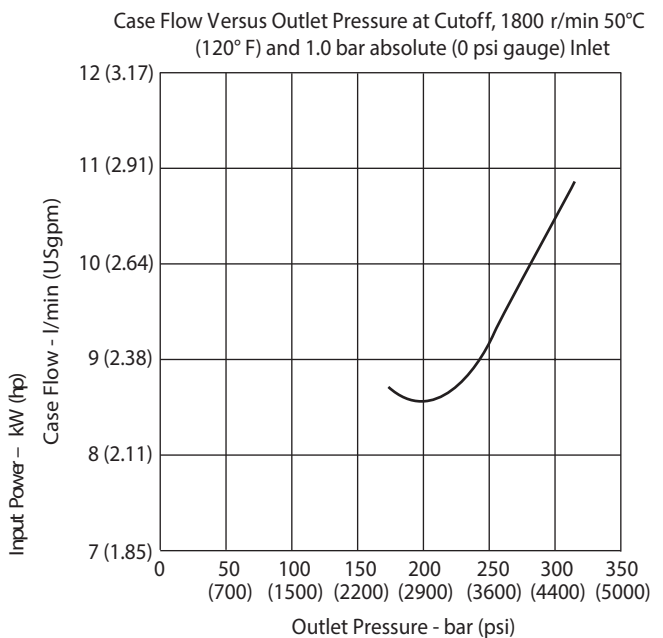
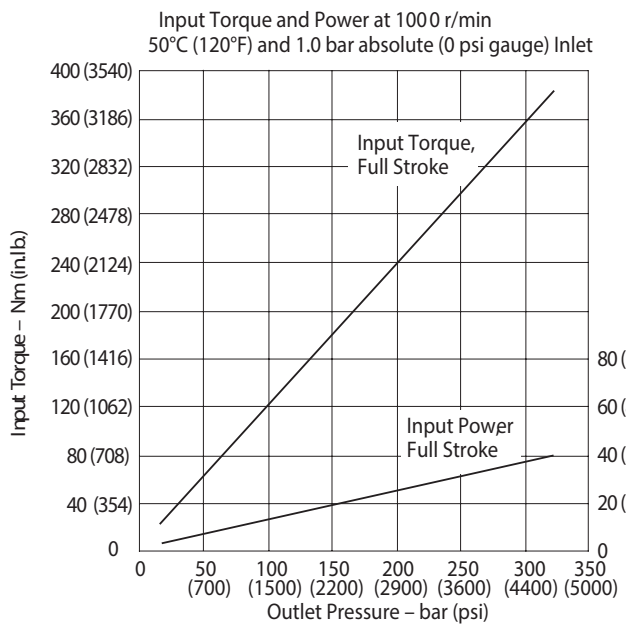
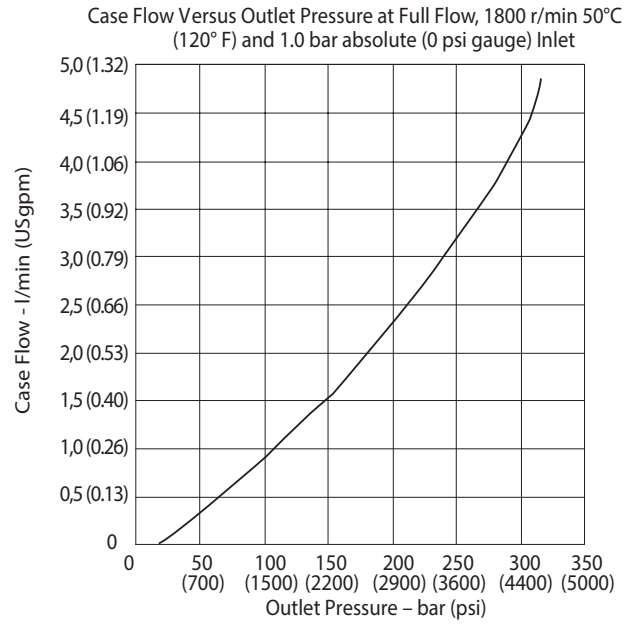
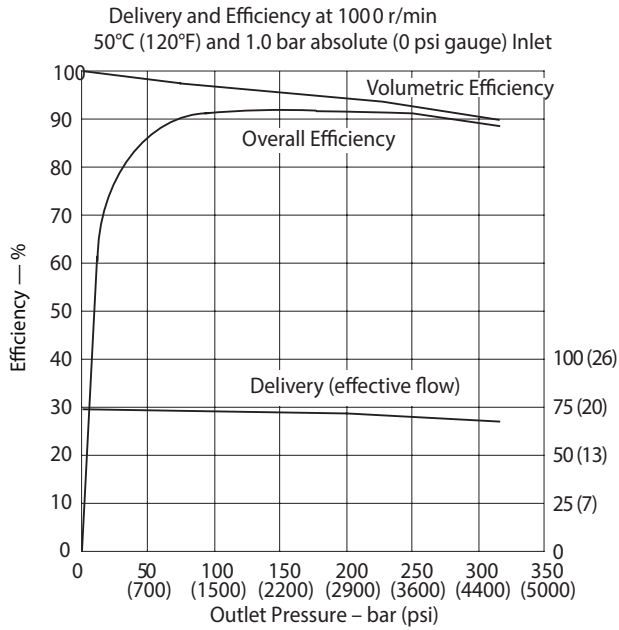

# Performance

Higher speed version (M)PVM074

Typical Noise Levels Petroleum Oil (10W) at 93°C (200°F), 1.0 bar absolute (0 psi gauge) Inlet (Sound pressure data equivalent to NFPA).

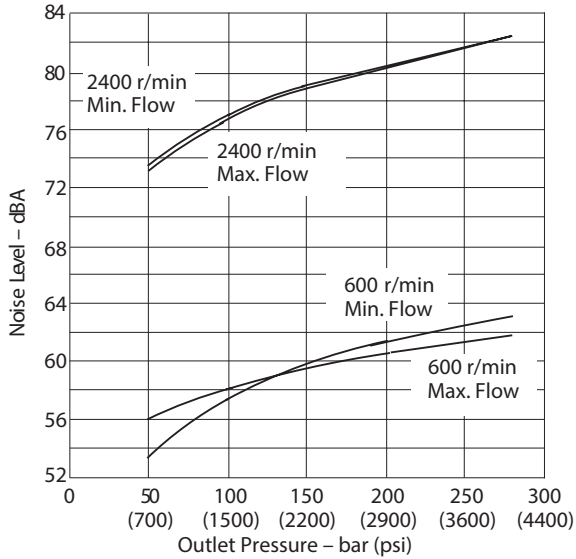

Delivery and Case Flow Versus Speed @ 93°C (200°F) and 1.0 bar absolute (0 psi gauge) inlet

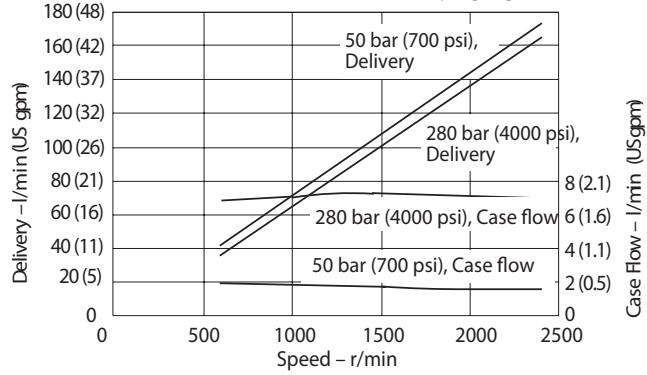

Input Torque Versus Speed @ 93°C (200°F) and 1.0 bar absolute (0 psi gauge) inlet

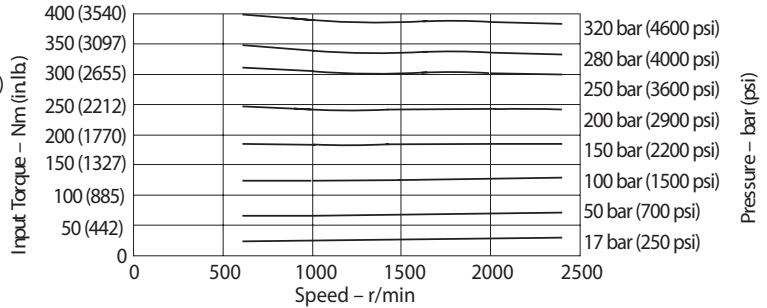

Overall Efficiency Versus Speed at 93°C (200°F) and 1.0 bar absolute (0 psi gauge) Inlet

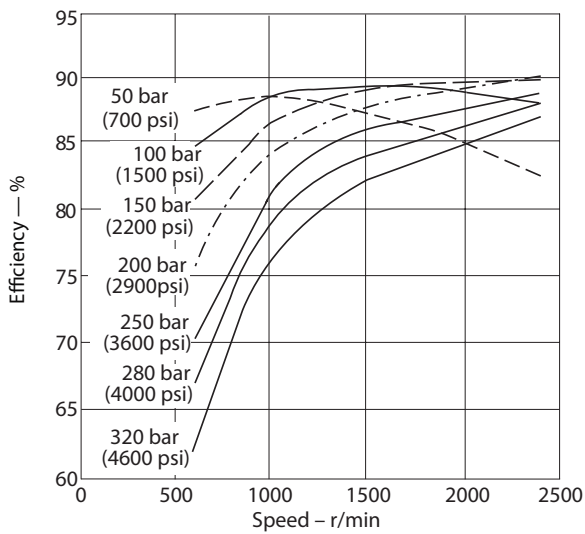

Input Power Versus Speed 93°C (200°F), 1.0 bar absolute (0 psi gauge) Inlet

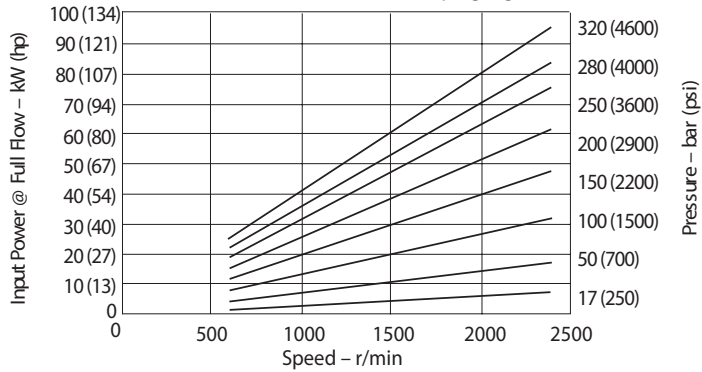

# Performance

Higher speed version (M)PVM074

Input Torque and Case Flow Versus Speed  
@ 93°C (200°F), load sense standby and  
1.0 bar absolute (0 psi gauge) inlet

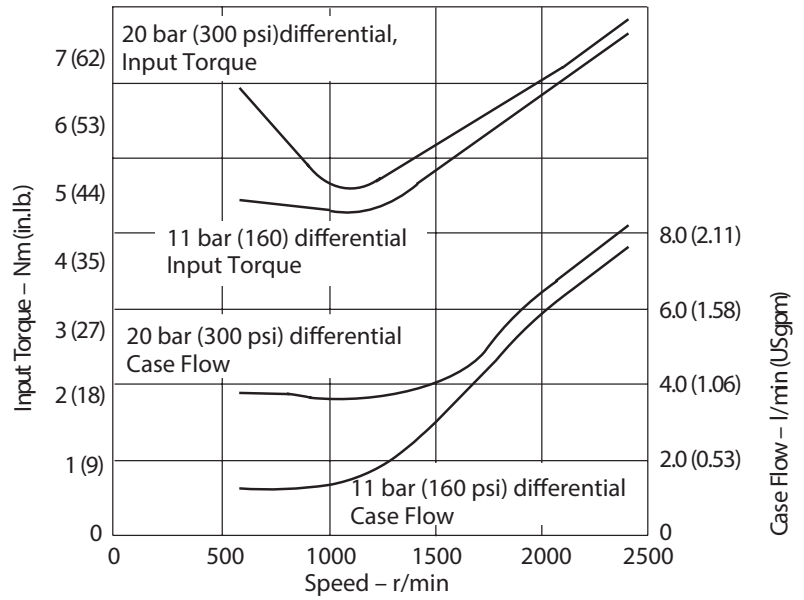

Input Torque and Case Flow Versus Speed  
@ 93°C (200°F), cut-off and  
1.0 bar absolute (0 psi gauge) inlet

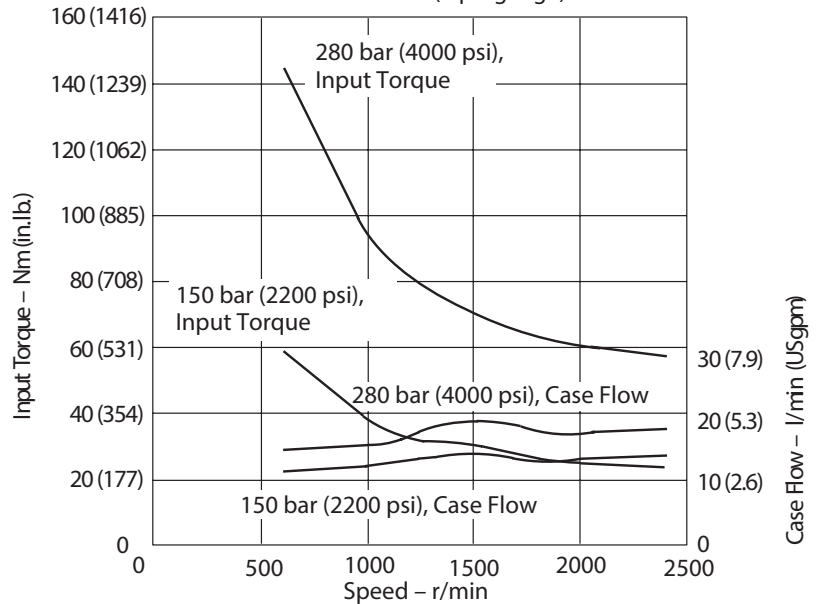

# Performance

Quiet version, optimized for 1000-1800 rpm (E) PVM081

Typical Noise Levels at 1800 and 1200 r/min. with Petroleum Oil (10W) at 50°C (120°F) and 1.0 bar absolute (0 psi gauge) Inlet

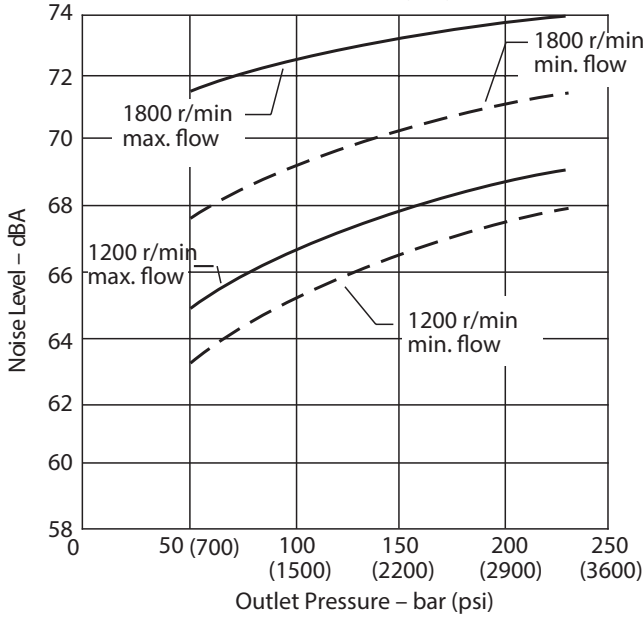

Delivery and Efficiency at 1800 r/min, 50C (120F), and 1.0 bar absolute (0 psi gauge) Inlet

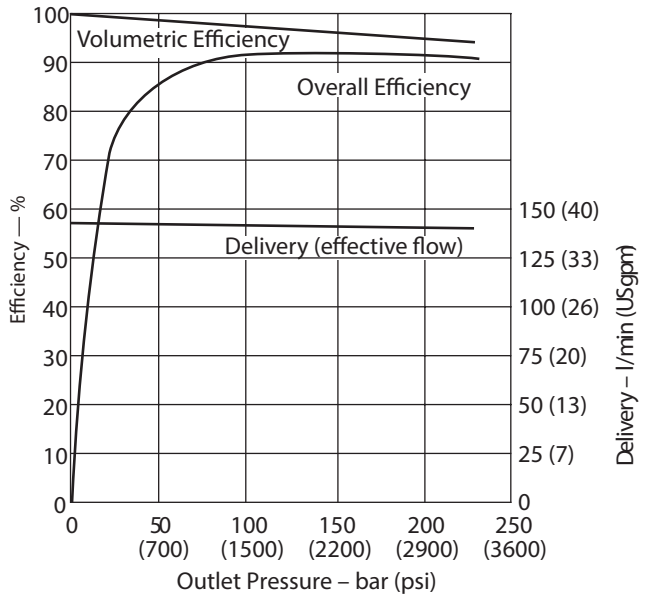

Typical Noise Levels at 1500 and 1000 r/min. with Petroleum Oil (10W) at 50°C (120°F) and 1.0 bar absolute (0 psi gauge) Inlet

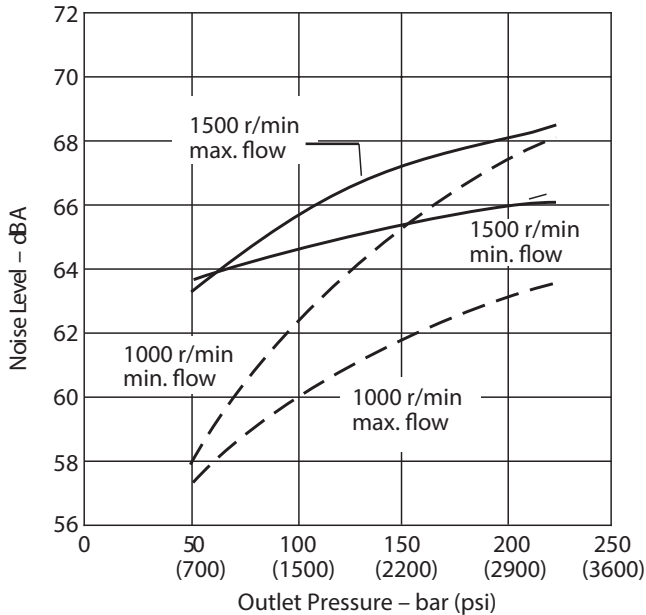

Sound pressure data equivalent to NFPA.

Input Torque and Power at 1800 r/min, 50C (120F), and 1.0 bar absolute (0 psi gauge) Inlet

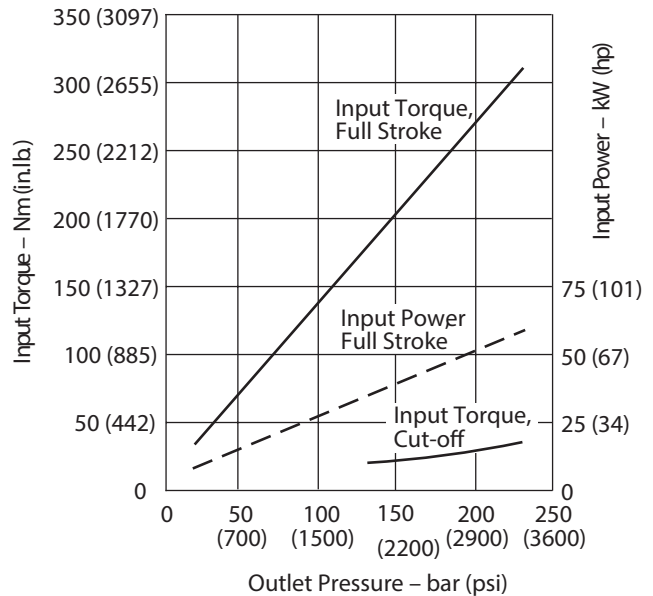

# Performance

Quiet version, optimized for 1000-1800 rpm (E) PVM081

Delivery and Efficiency at 1500 r/min, 50C (120F), and 1.0 bar absolute (0 psi gauge) Inlet

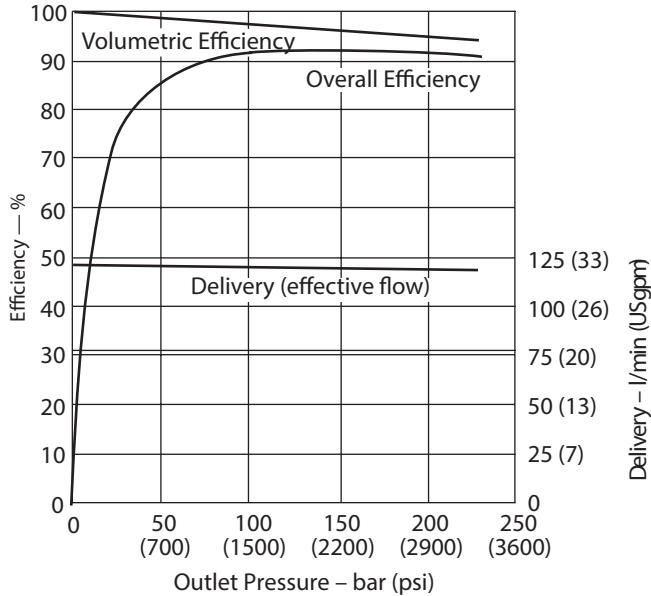

Delivery and Efficiency at 1200 r/min, 50C (120F), and 1.0 bar absolute (0 psi gauge) Inlet

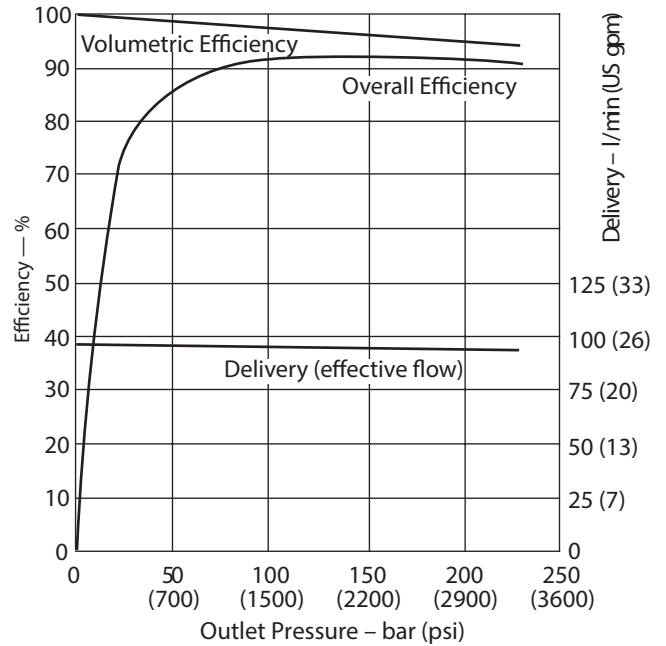

Input Torque and Power at 1500 r/min, 50C (120F), and 1.0 bar absolute (0 psi gauge) Inlet

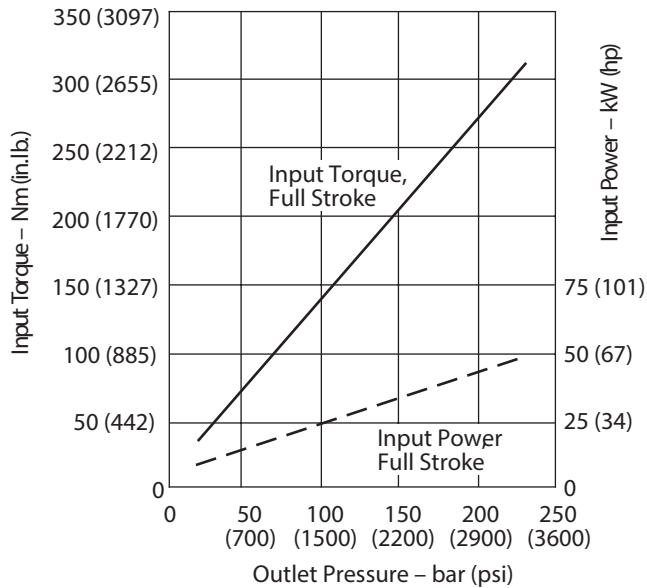

Input Torque and Power at 1200 r/min, 50C (120F), and 1.0 bar absolute (0 psi gauge) Inlet

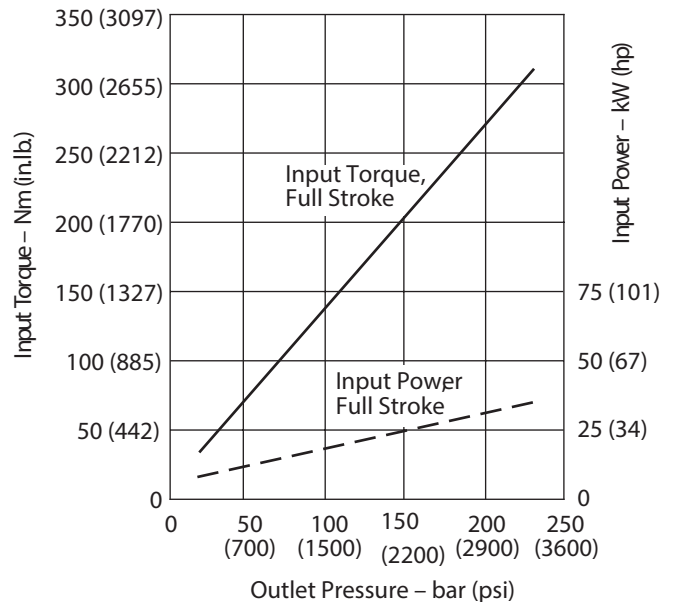

# Performance

Quiet version, optimized for 1000-1800 rpm (E) PVM081

Delivery and Efficiency at 1000 r/min, 50C (120F), and 1.0 bar absolute (0 psi gauge) Inlet

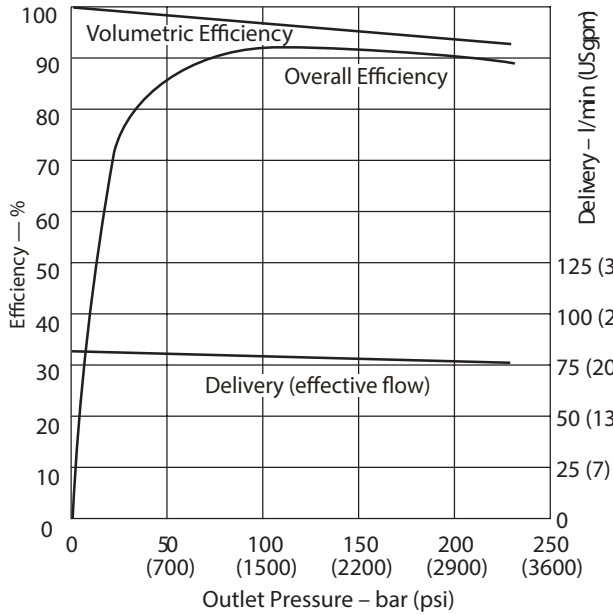

Case Flow versus Outlet Pressure at 1800 r/min, Full Flow, 50°C (120°F), and 1.0 bar absolute (0 psi gauge) Inlet

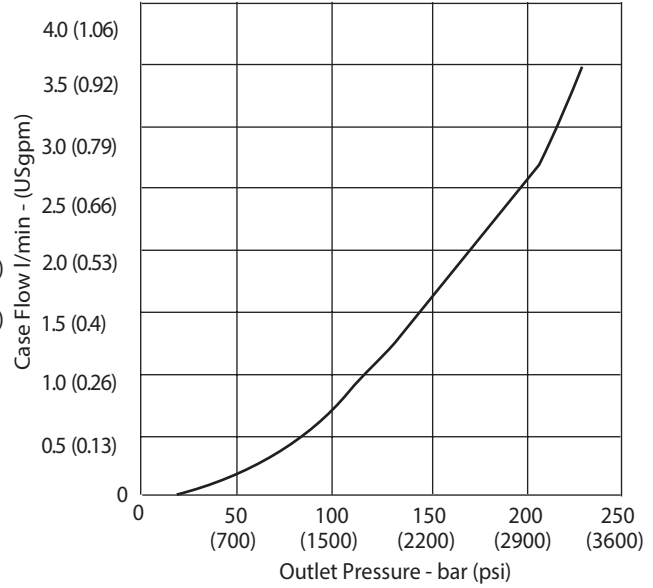

Input Torque and Power at 1000 r/min, 50C (120F), and 1.0 bar absolute (0 psi gauge) Inlet

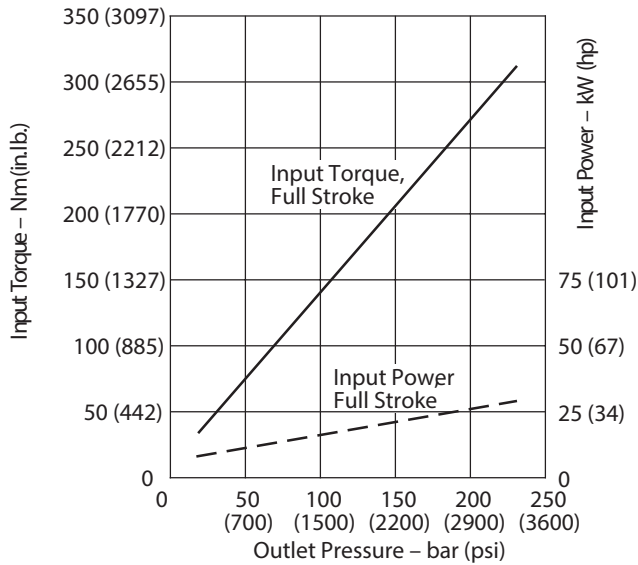

Case Flow versus Outlet Pressure at Cutoff, 1800 r/min, 50°C (120°F), and 1.0 bar absolute (0 psi gauge) Inlet

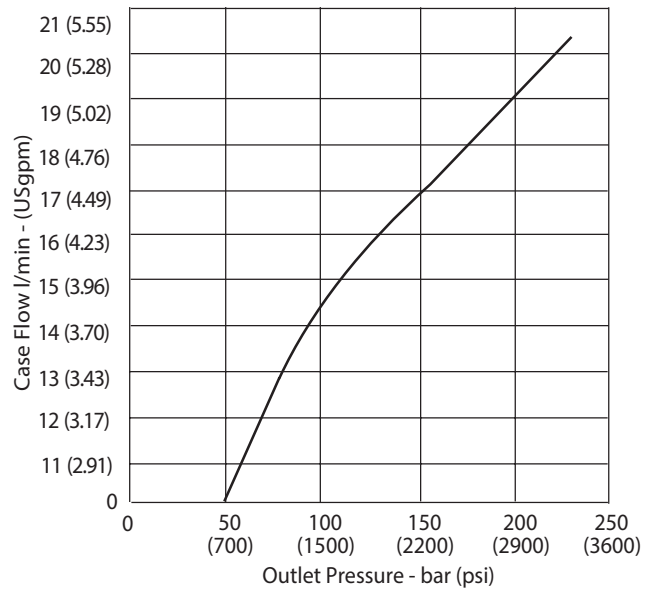



# Performance

Higher speed version (M)PVM081

Typical Noise Levels at 2400 & 600 r/min with Petroleum Oil (10W) at 93°C (200°F) and 1.0 bar absolute (0 psi gauge) Inlet

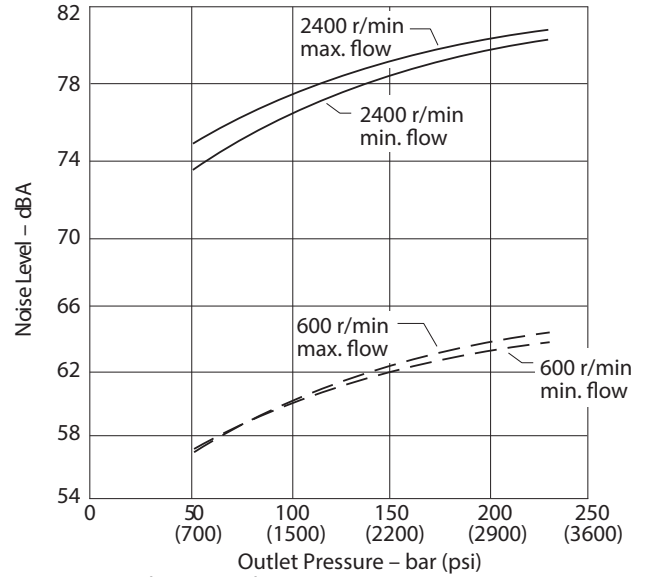

Sound pressure data equivalent to NFPA.

Overall Efficiency versus Speed at 93°C (200°F) and 1.0 bar absolute (0 psi gauge) inlet

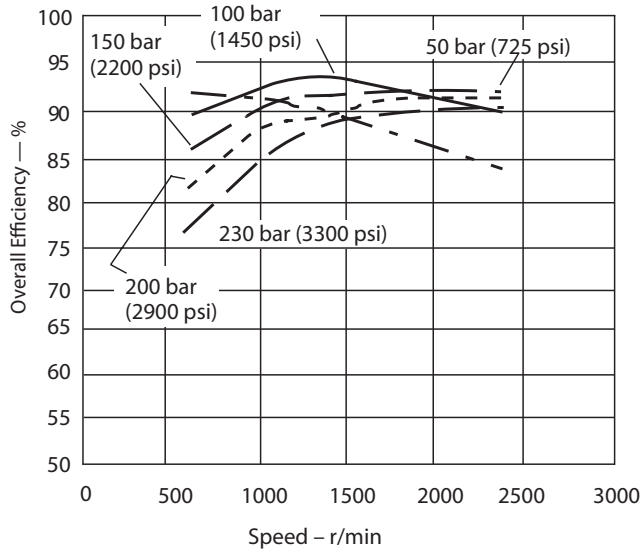

Delivery and Case Flow versus Speed at 93°C (200°F), Full Flow 1.0 bar absolute (0 psi gauge) Inlet

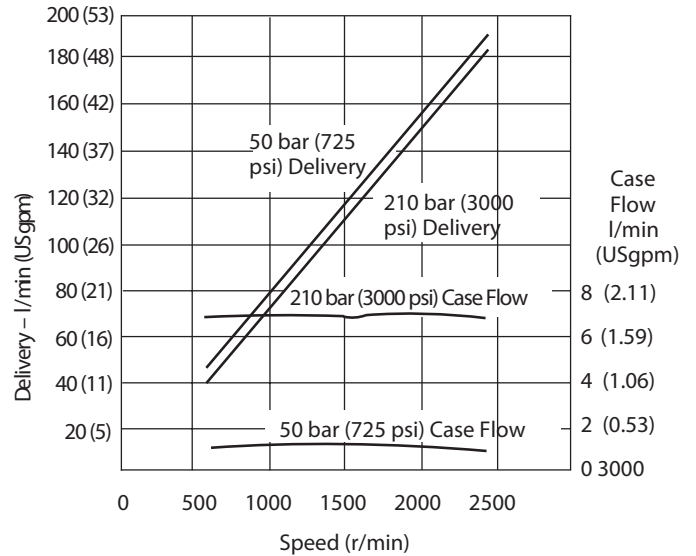

# Performance

Higher speed version (M)PVM081

Input Torque versus Speed at 93°C (200°F), Full Flow and 1.0 bar absolute (0 psi gauge) Inlet

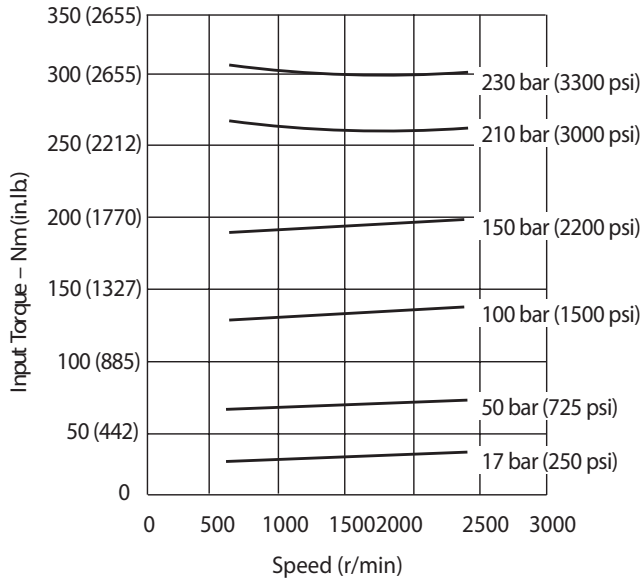

Input Power versus Speed at 93°C (200°F), Full Flow and 1.0 bar absolute (0 psi gauge) Inlet

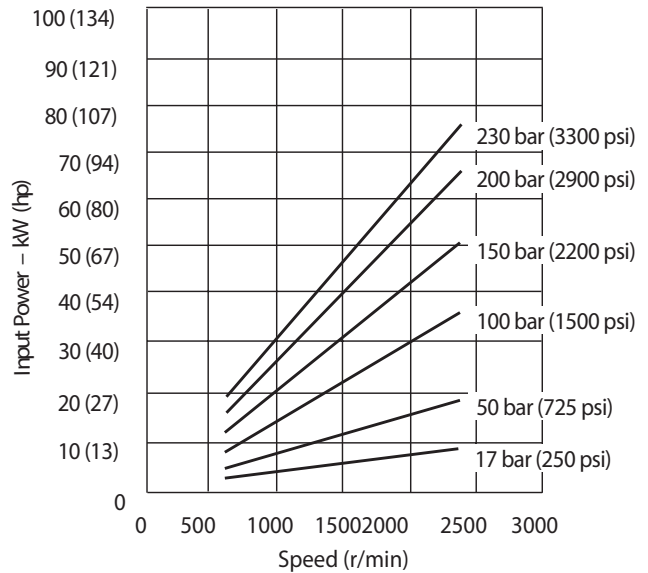

Input Torque and Case Flow versus Speed at 93°C (200°F), Load Sense Standby and 1.0 bar absolute (0 psi gauge) Inlet

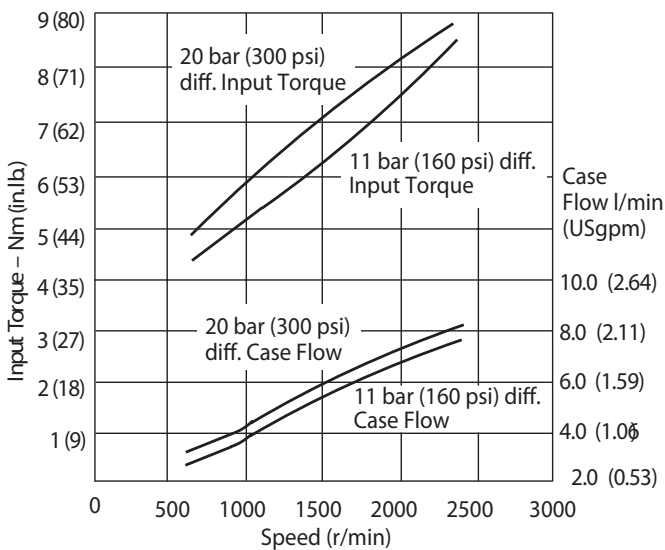

Input Torque and Case Flow versus Speed at 93°C (200°F), Pressure Limit Cut-off and 1.0 bar absolute (0 psi gauge) Inlet

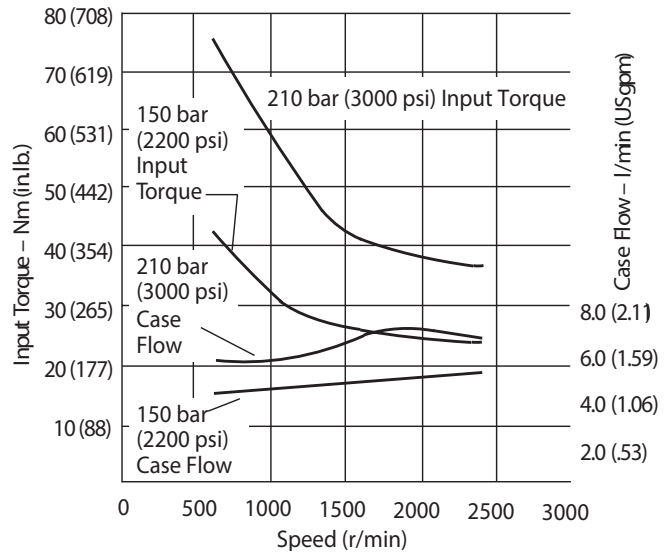

# Performance

Quiet version, optimized for 1000-1800 rpm (E) PVM098

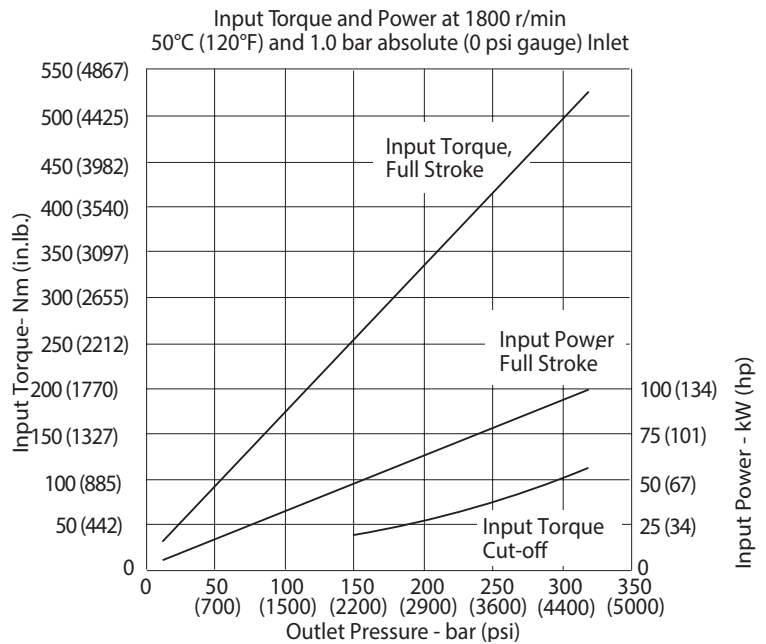
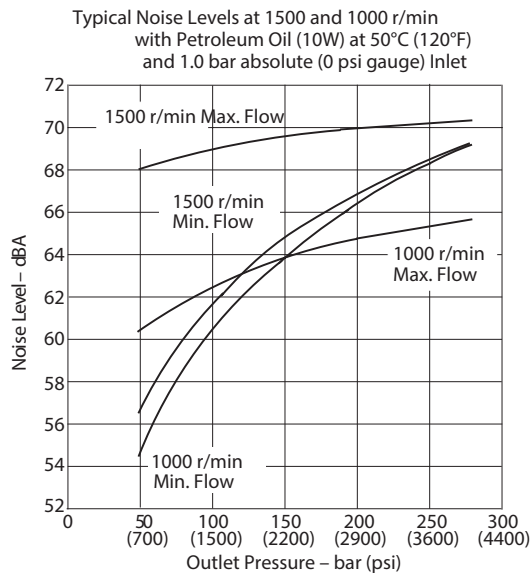
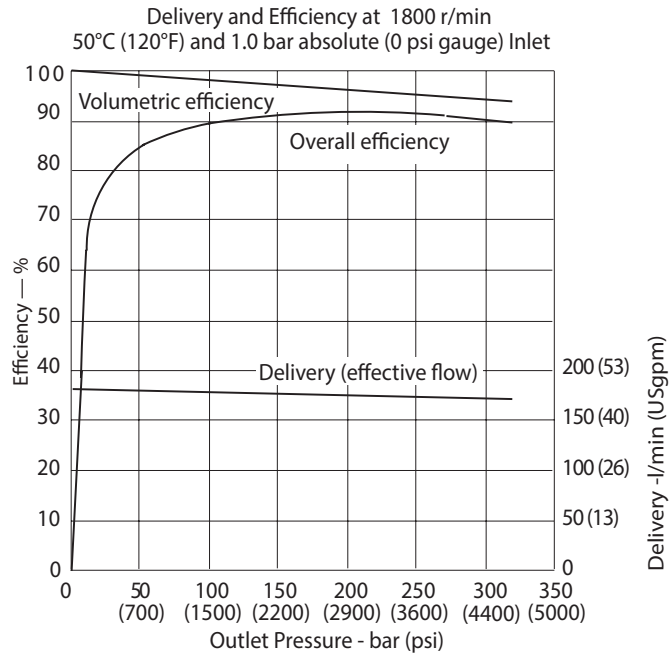
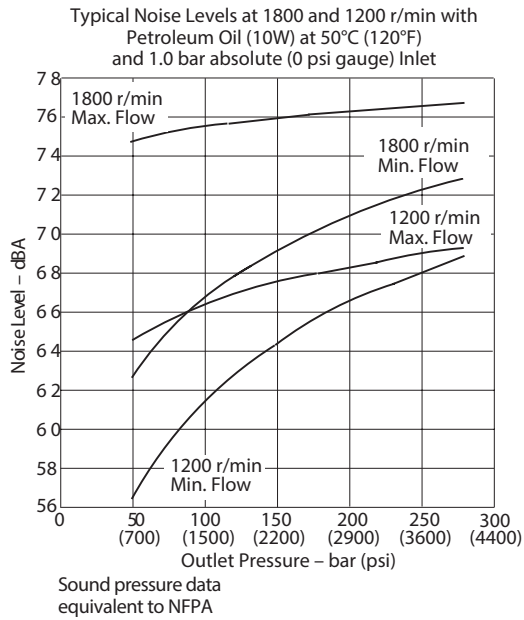

# Performance

Quiet version, optimized for 1000-1800 rpm (E) PVM098

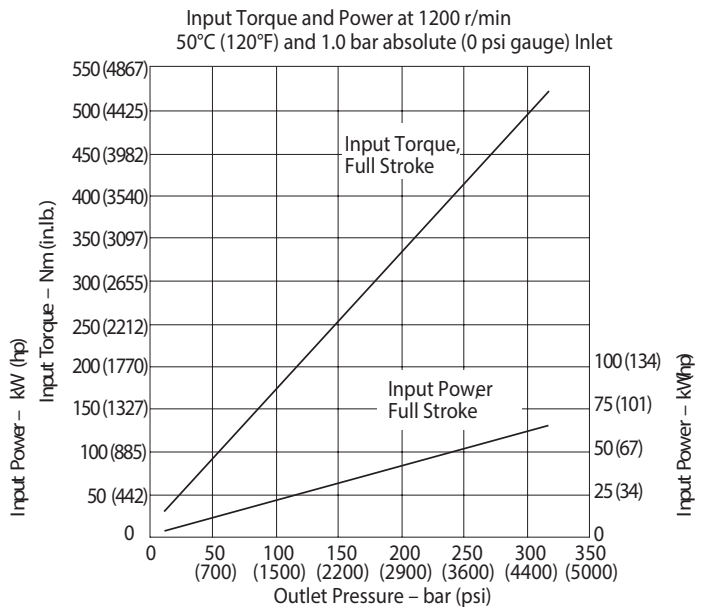
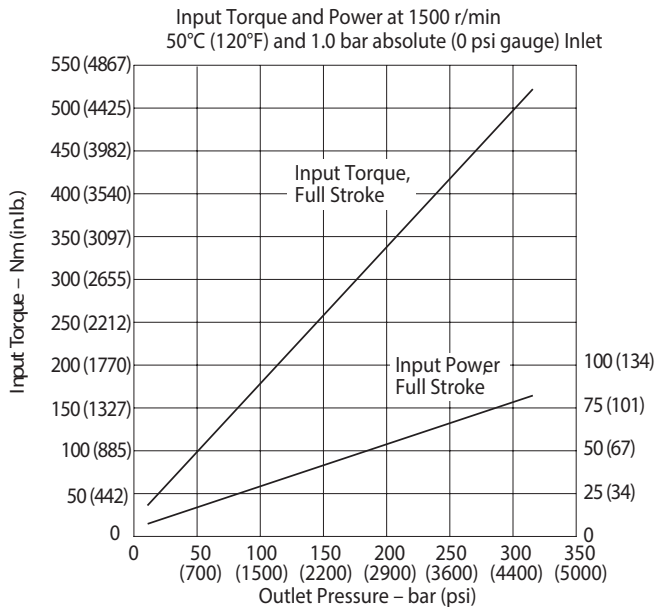
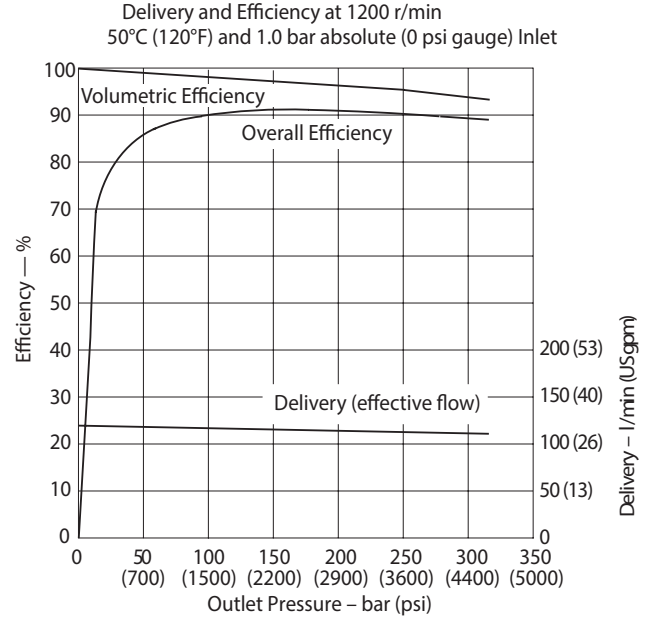
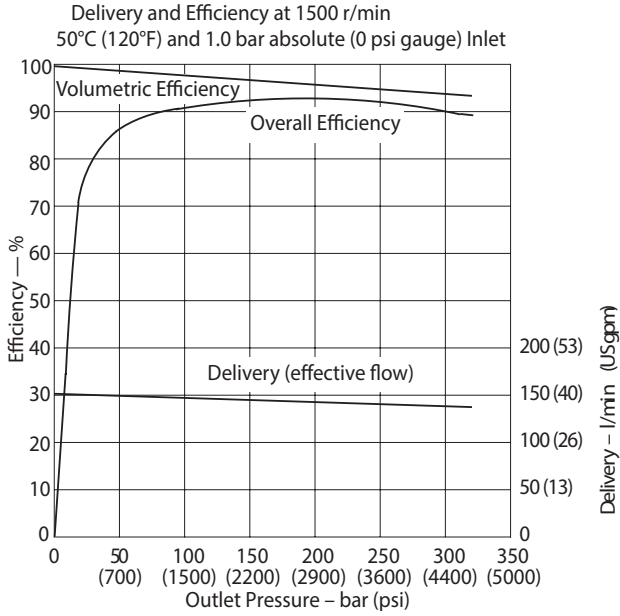

# Performance

Quiet version, optimized for 1000-1800 rpm (E) PVM098

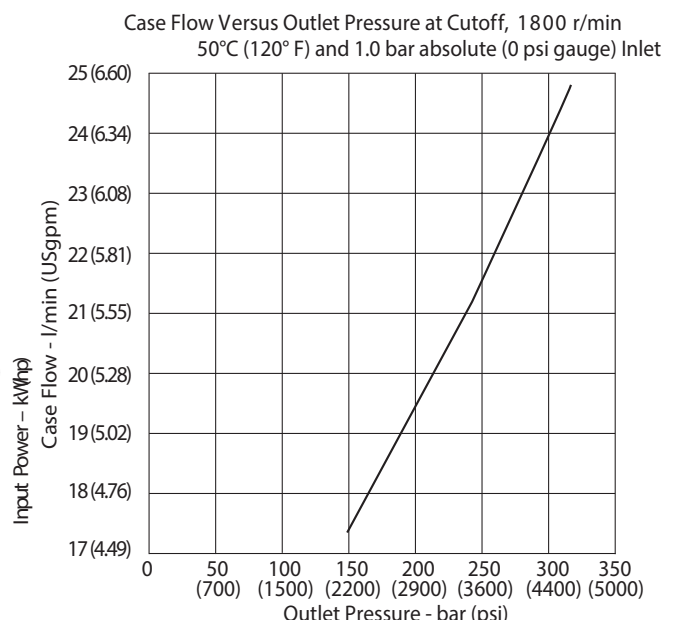
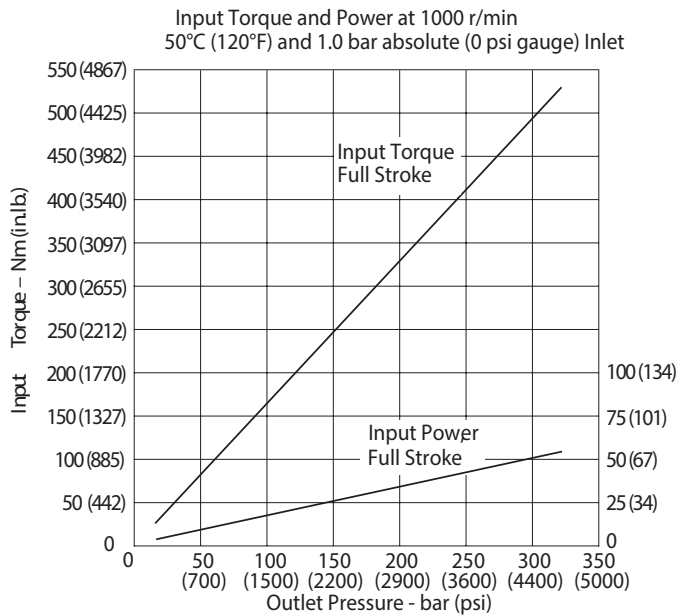
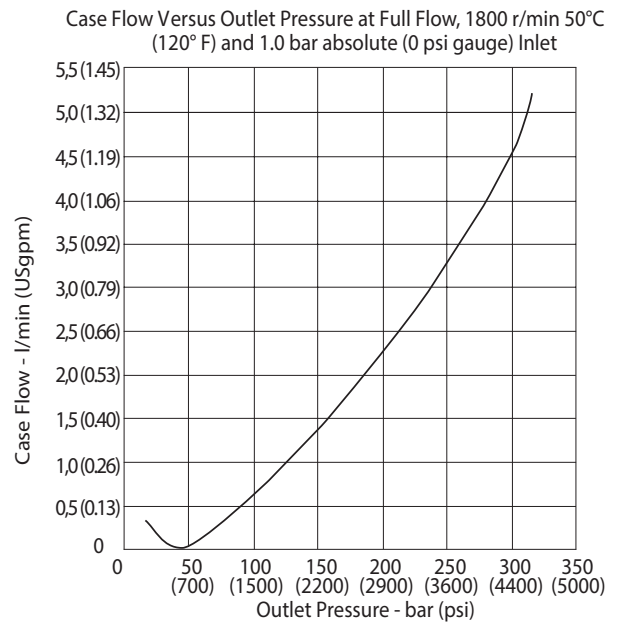
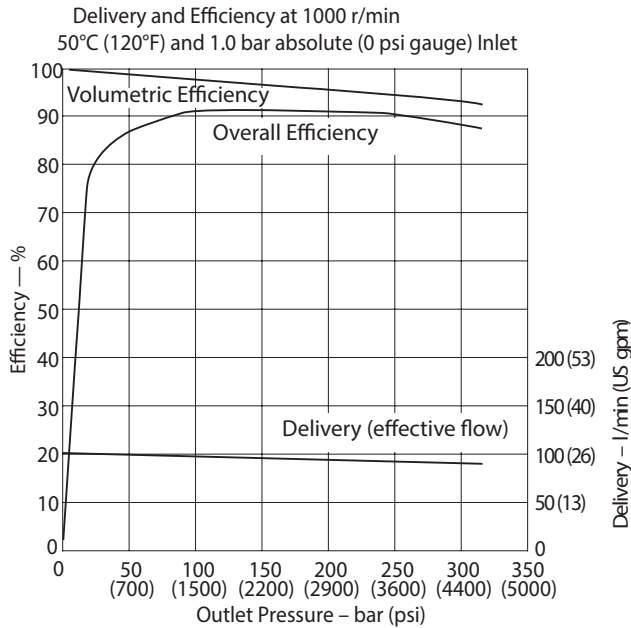

# Performance

Higher speed version (M)PVM098

Typical Noise Levels at 2000 and 600 r/min with petroleum oil (10 W) @ 93°C (200°F) and 1.0 bar absolute (0 psi gauge) inlet

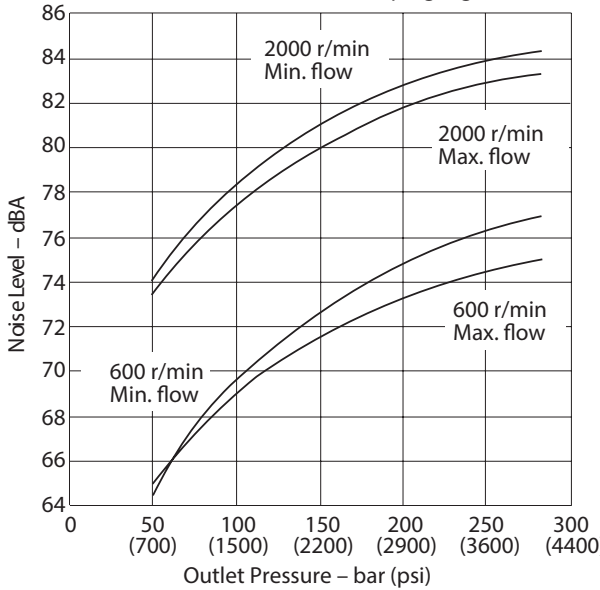

Sound pressure data equivalent to NFPA.

Delivery and Case Flow Versus Speed @ 93°C (200°F), full flow and 1.0 bar absolute (0 psi) gauge Inlet

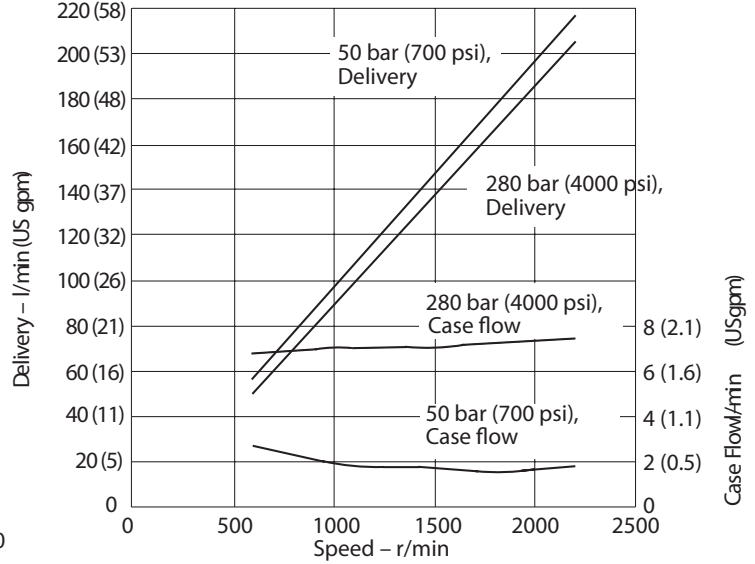

Overall Efficiency Versus Speed @ 93°C (200°F) and 1.0 bar absolute (0 psi gauge) inlet

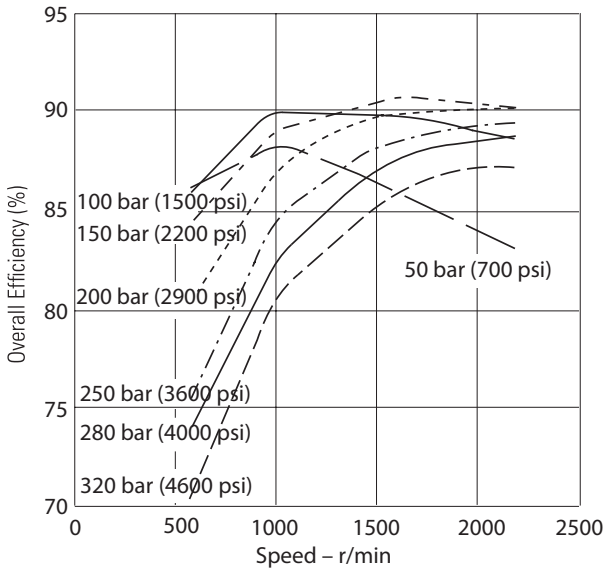

Input Torque Versus Speed @ 93°C (200°F), full flow and 1.0 bar absolute (0 psi gauge) inlet

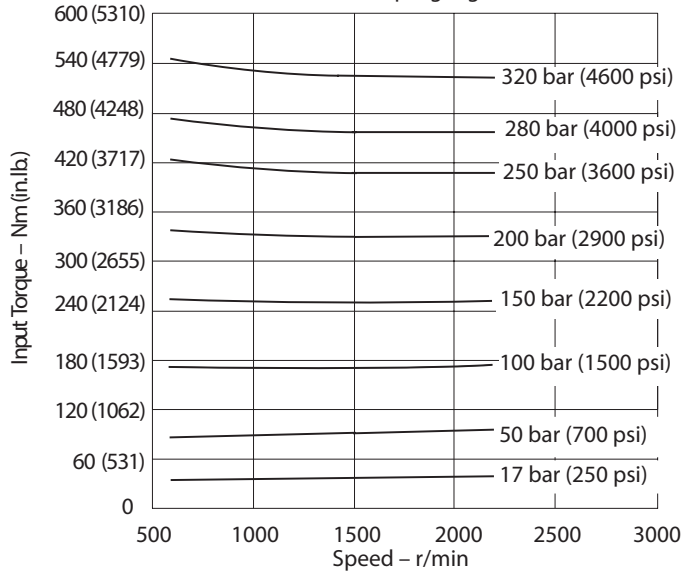

# Performance

Higher speed version (M)PVM098

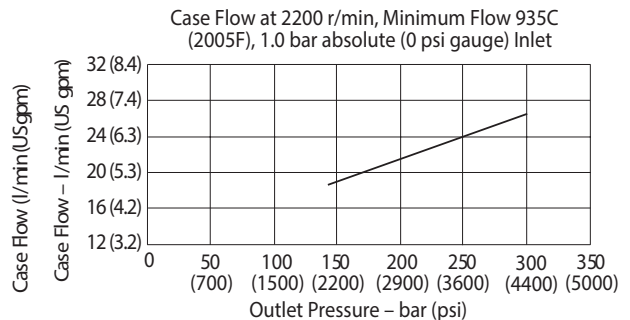
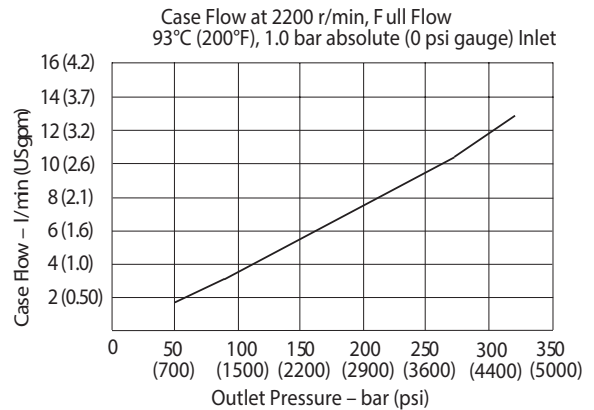
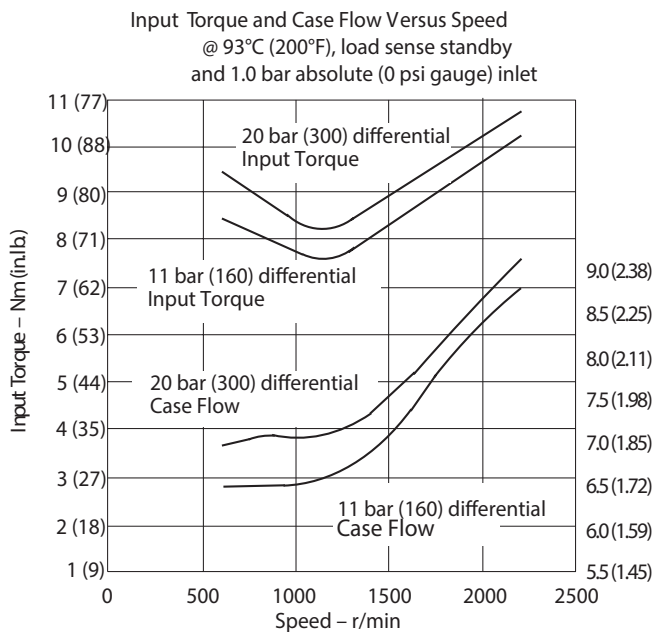
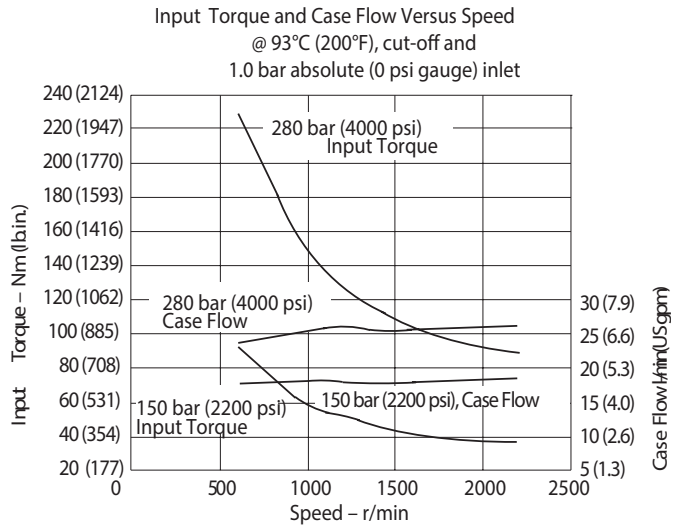
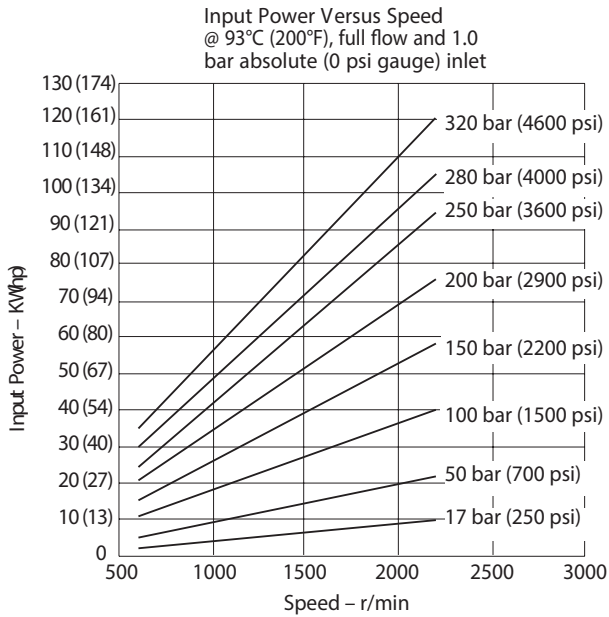

# Performance

Quiet version, optimized for 1000-1800 rpm (E) PVM106

Typical Noise Levels at 1800 and 1200 r/min. with Petroleum Oil (10W) at 50°C (120°F) and 1.0 bar absolute (0 psi gauge) Inlet

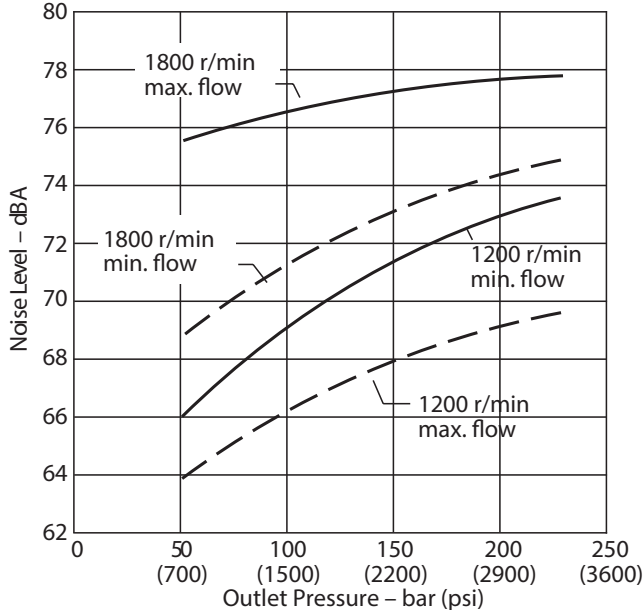

Delivery and Efficiency at 1800 r/min, 50C (120F), and 1.0 bar absolute (0 psi gauge) Inlet

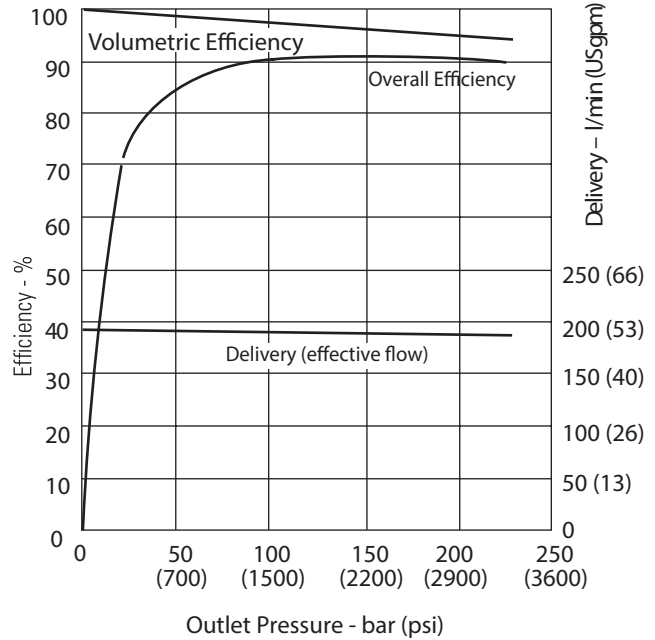

Typical Noise Levels at 1500 and 1000 r/min. with Petroleum Oil (10W) at 50°C (120°F) and 1.0 bar absolute (0 psi gauge) Inlet

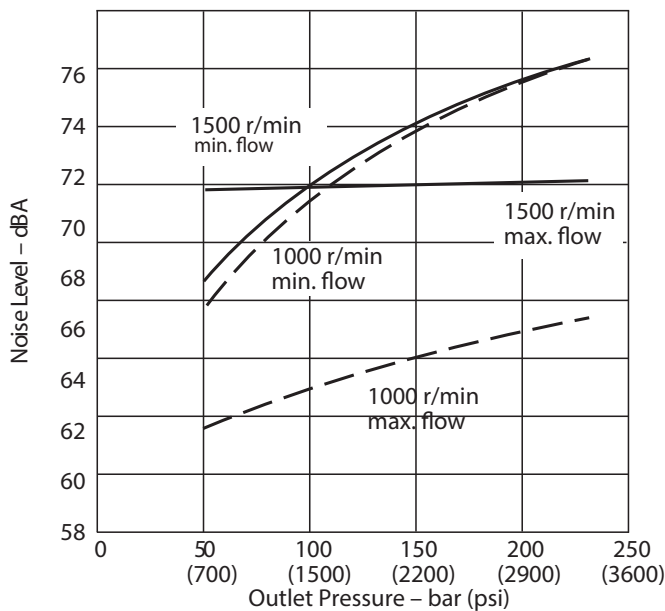

Input Torque and Power at 1800 r/min, 50C (120F), and 1.0 bar absolute (0 psi gauge) Inlet

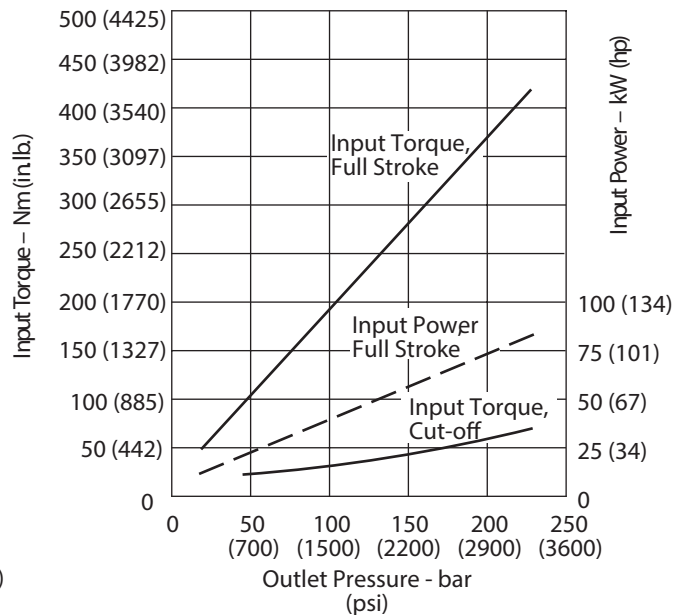

Sound pressure data equivalent to NFPA.



# Performance

Quiet version, optimized for 1000-1800 rpm (E) PVM106

Delivery and Efficiency at 1500 r/min, 50C (120F), and 1.0 bar absolute (0 psi gauge) Inlet

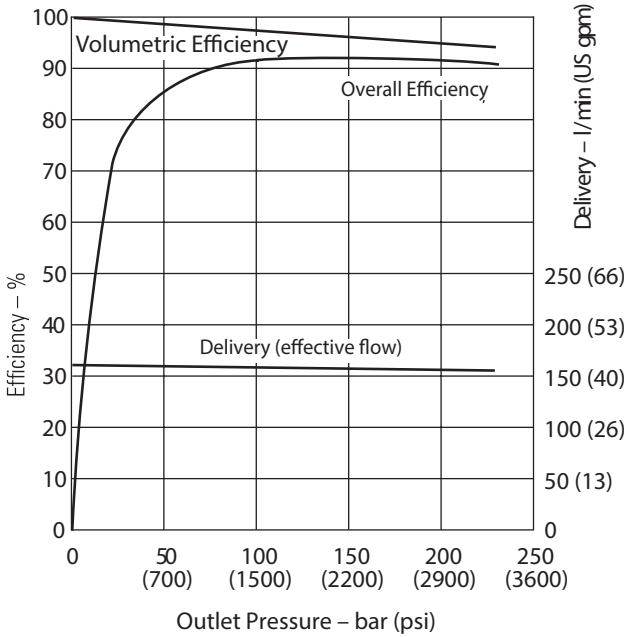

Delivery and Efficiency at 1200 r/min, 50C (120F), and 1.0 bar absolute (0 psi gauge) Inlet

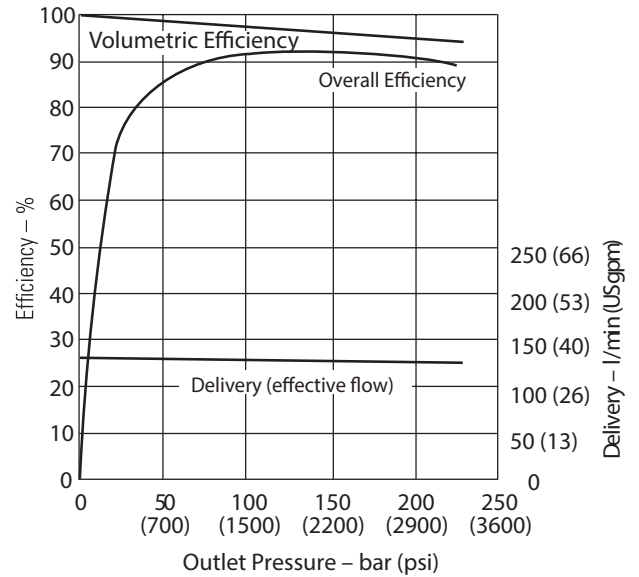

Input Torque and Power at 1500 r/min, 50C (120F), and 1.0 bar absolute (0 psi gauge) Inlet

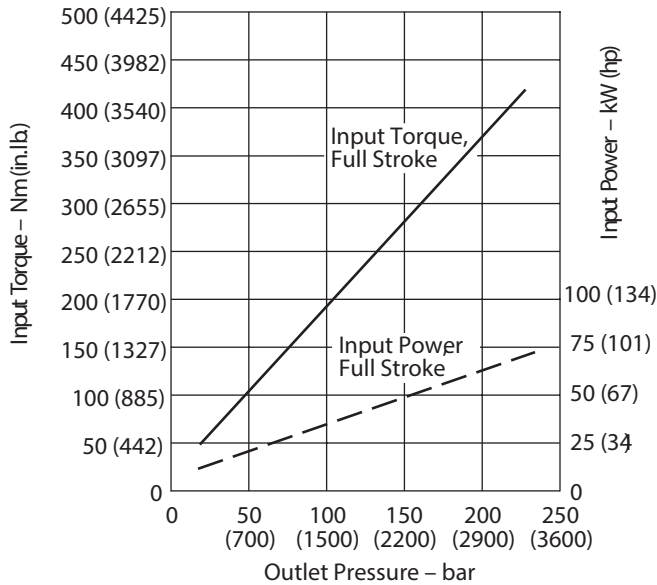

Input Torque and Power at 1200 r/min, 50C (120F), and 1.0 bar absolute (0 psi gauge) Inlet

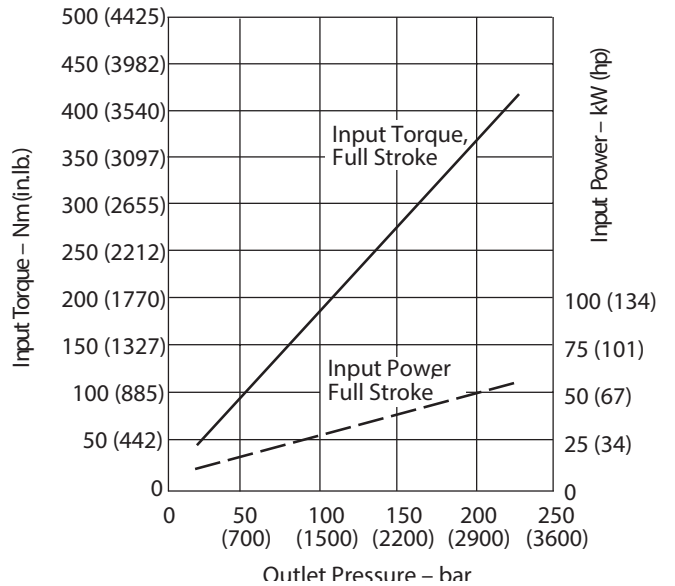

# Performance

Quiet version, optimized for 1000-1800 rpm (E) PVM106

Delivery and Efficiency at 1000 r/min, 50C (120F), and 1.0 bar absolute (0 psi gauge) Inlet

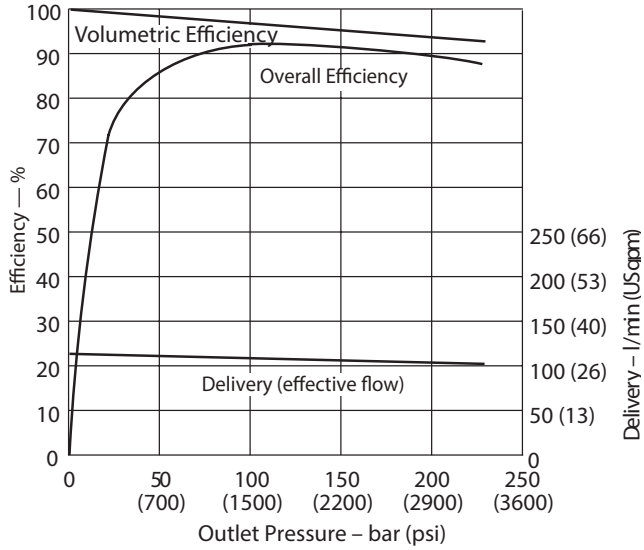

Case Flow versus Outlet Pressure at 1800 r/min, Full Flow, 50°C (120°F), and 1.0 bar absolute (0 psi gauge) Inlet

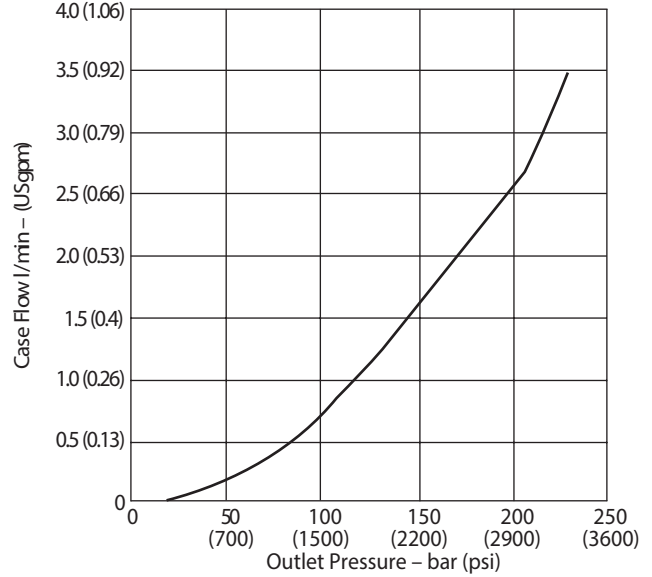

Input Torque and Power at 1000 r/min, 50C (120F), and 1.0 bar absolute (0 psi gauge) Inlet

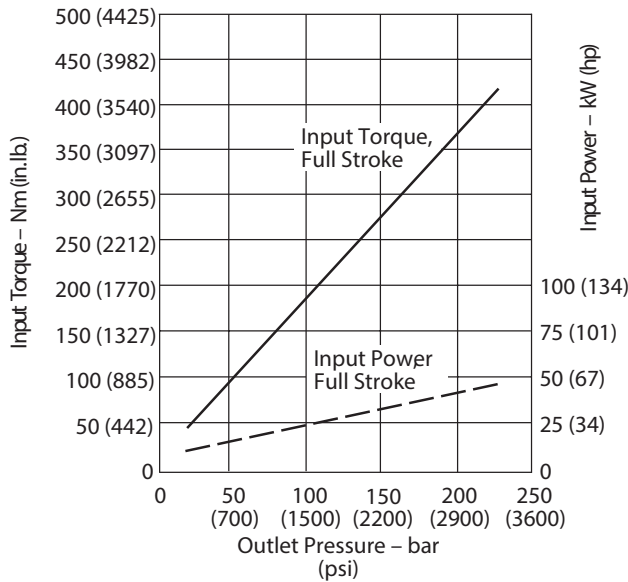

Case Flow versus Outlet Pressure at Cutoff, 1800 r/min, 50°C (120°F), and 1.0 bar absolute (0 psi gauge) Inlet

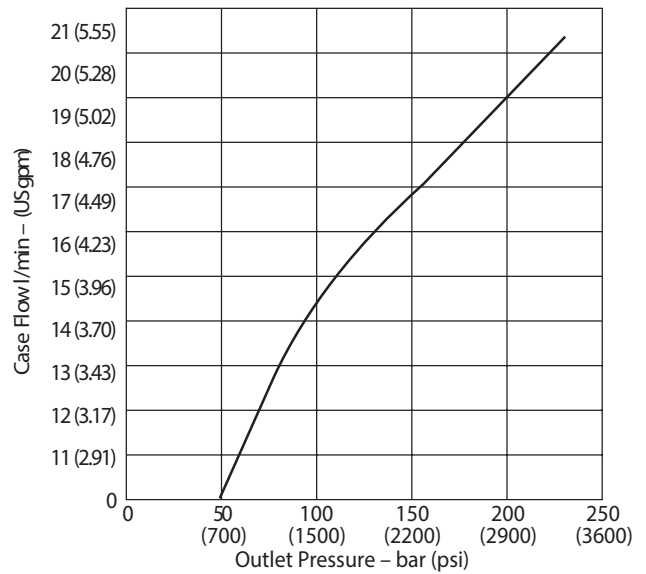

# Performance

Higher speed version (M)PVM106

Typical Noise Levels at 2200 & 600 r/min with Petroleum Oil (10W) at 93°C (200°F) and 1.0 bar absolute (0 psi gauge) Inlet

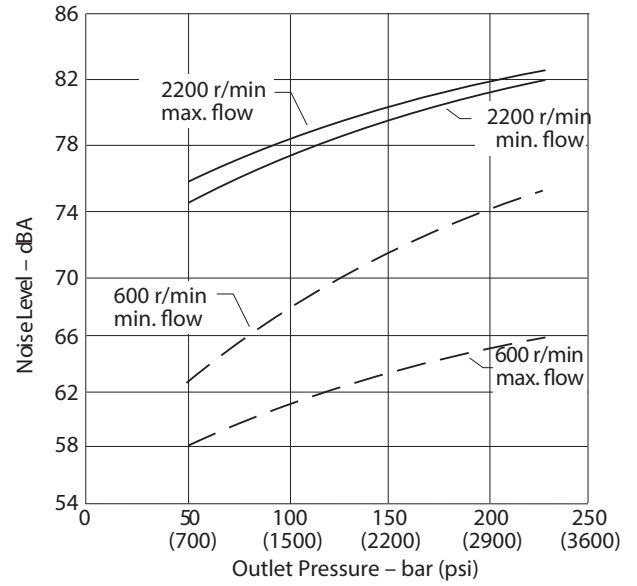

Sound pressure data equivalent to NFPA.

Overall Efficiency versus Speed at 93°C (200°F) and 1.0 bar absolute (0 psi gauge) inlet

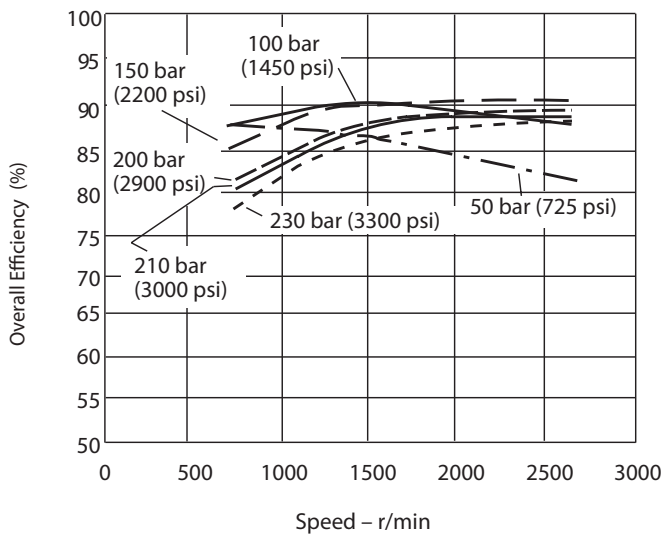

Delivery and Case Flow versus Speed at 93°C (200°F), Full Flow 1.0 bar absolute (0 psi gauge) Inlet

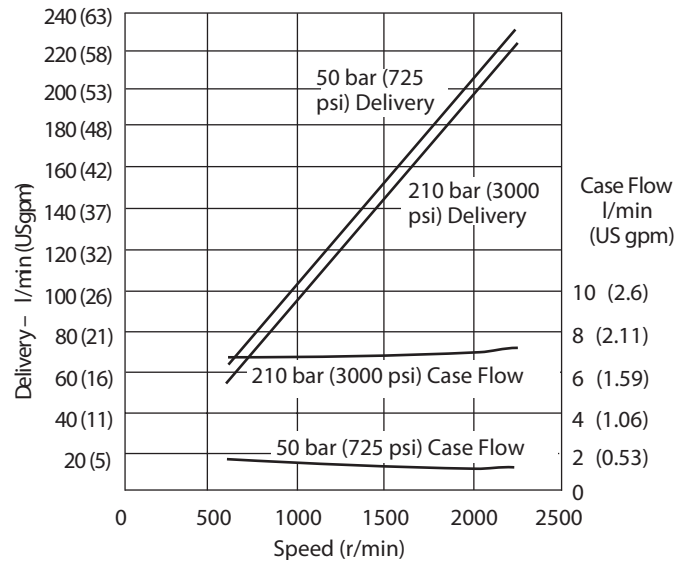

# Performance

Higher speed version (M)PVM106

Input Torque versus Speed at 93°C (200°F), Full Flow and 1.0 bar absolute (0 psi gauge) Inlet

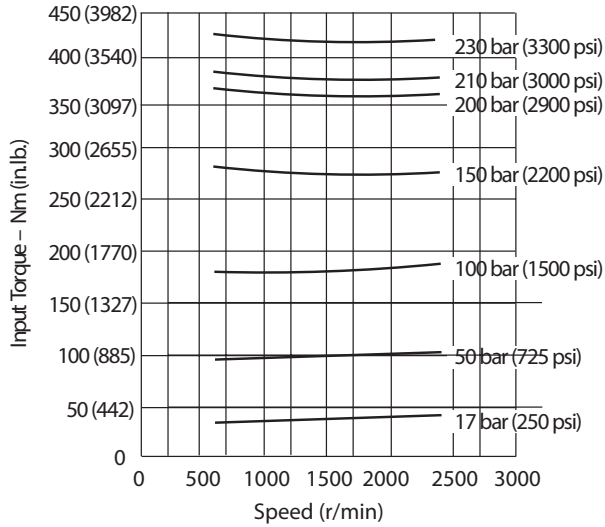

Input Power versus Speed at 93°C (200°F), Full Flow and 1.0 bar absolute (0 psi gauge) Inlet

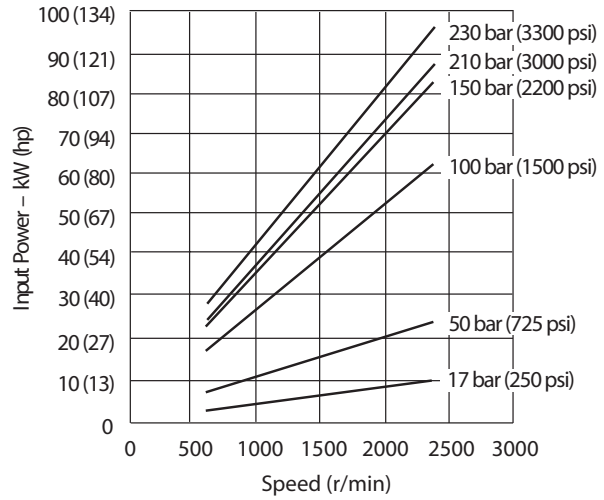

Input Torque and Case Flow versus Speed at 93°C (200°F), Load Sense Standby and 1.0 bar absolute (0 psi gauge) Inlet

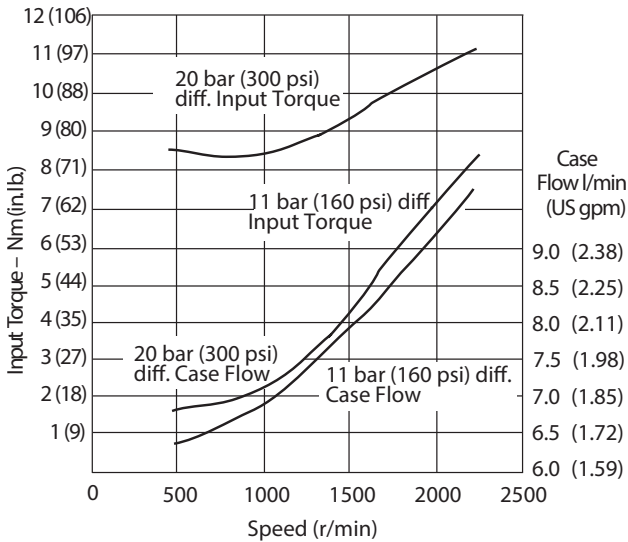

Input Torque and Case Flow versus Speed at 93°C (200°F), Pressure Limit Cut-off and 1.0 bar absolute (0 psi gauge) Inlet

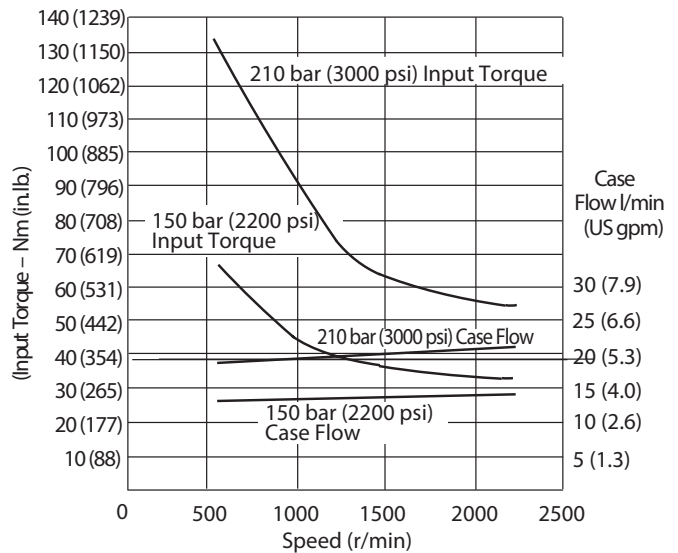

# Performance

Quiet version, optimized for 1000-1800 rpm (E) PVM131

Typical Noise Levels at 1800 and 1200 r/min with Petroleum Oil (10W) at 50°C (120°F) and 1.0 bar absolute (0 psi gauge) Inlet

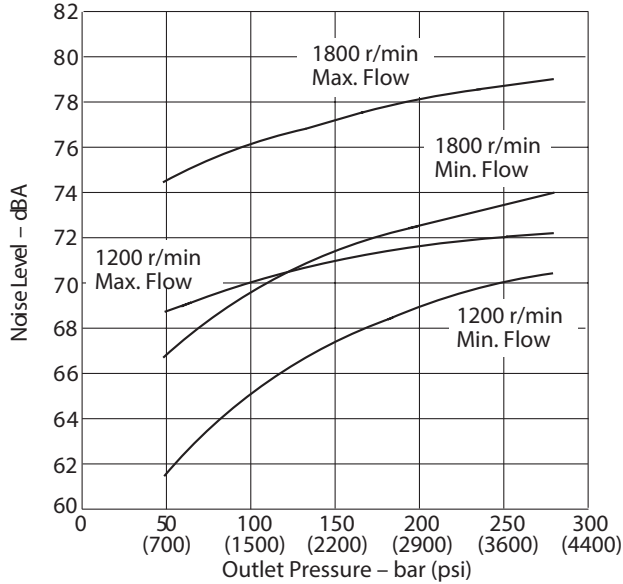

Sound pressure data equivalent to NFPA.

Delivery and Efficiency at 1800 r/min 50°C (120°F) and 1.0 bar absolute (0 psi gauge) Inlet

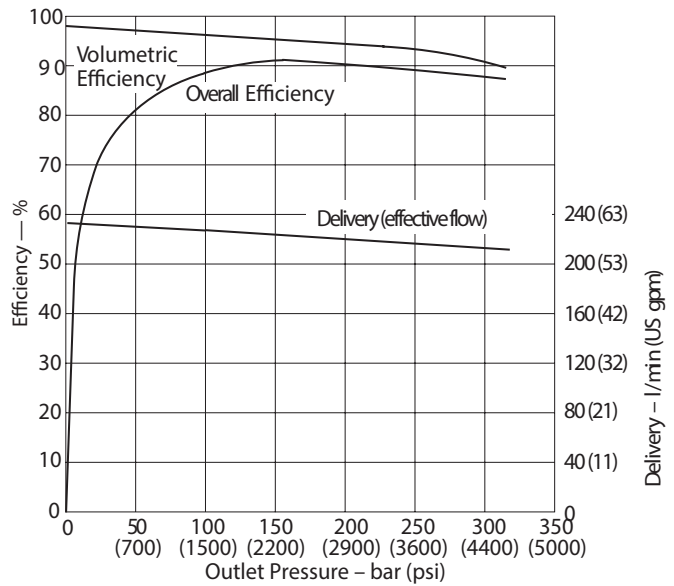

Typical Noise Levels at 1500 and 1000 r/min with Petroleum Oil (10W) at 50°C (120°F) and 1.0 bar absolute (0 psi gauge) Inlet

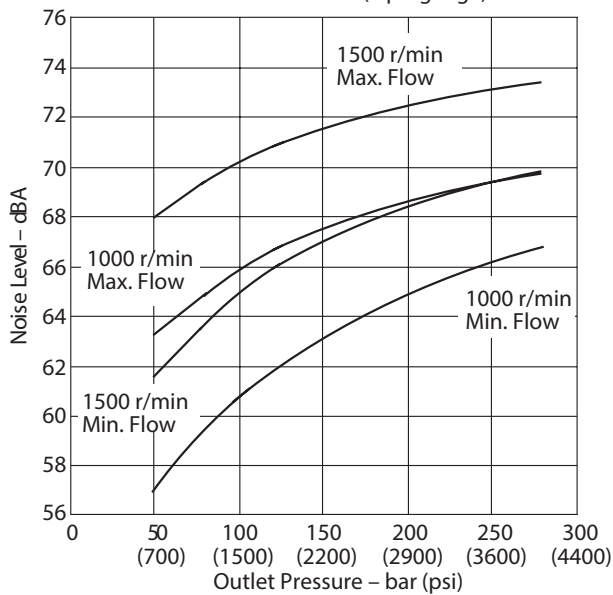

Input Torque and Power at 1800 r/min 50°C (120°F) and 1.0 bar absolute (0 psi gauge) Inlet

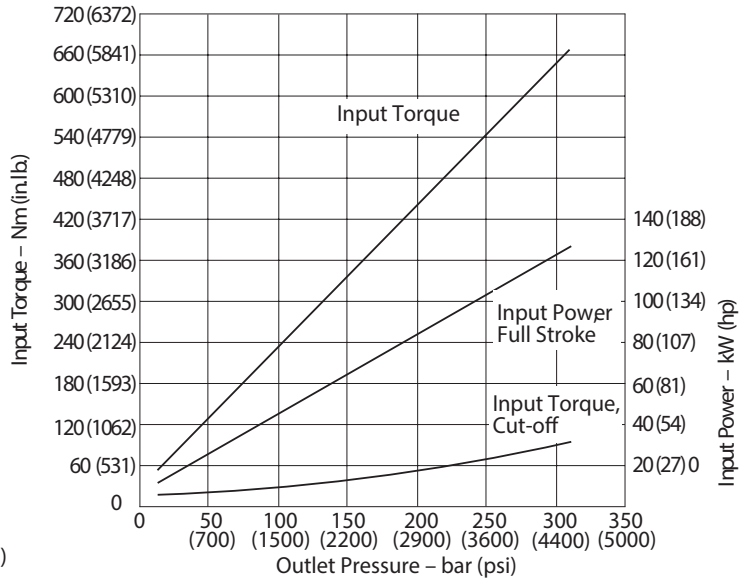

# Performance

Quiet version, optimized for 1000-1800 rpm (E) PVM131

Delivery and Efficiency at 1500 r/min  
50°C (120°F) and 1.0 bar absolute (0 psi gauge) Inlet

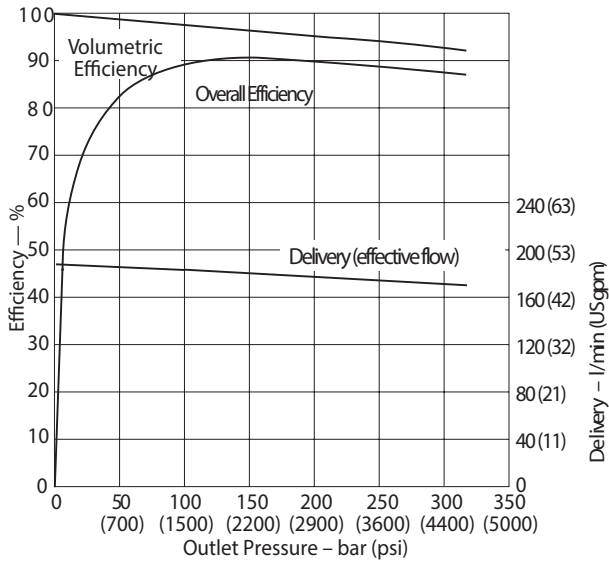

Delivery and Efficiency at 1200 r/min  
50°C (120°F) and 1.0 bar absolute (0 psi gauge) Inlet

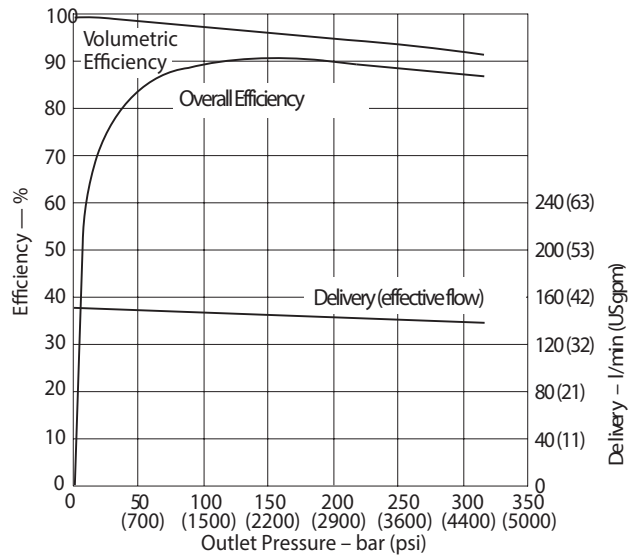

Input Torque and Power at 1500 r/min  
50°C (120°F) and 1.0 bar absolute (0 psi gauge) Inlet

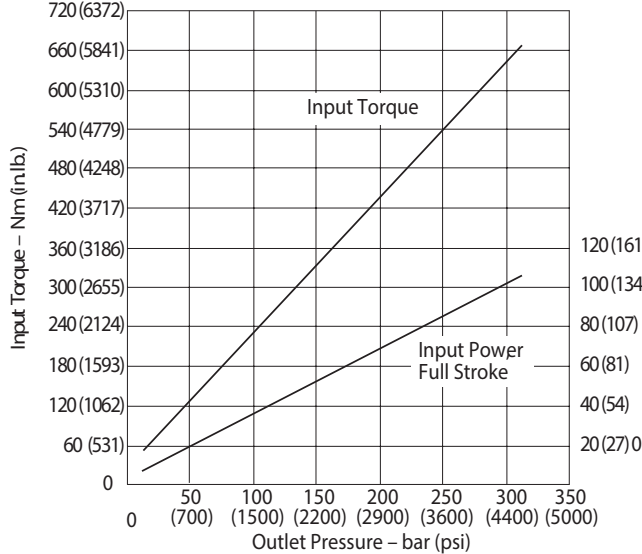

Input Torque and Power at 1200 r/min  
50°C (120°F) and 1.0 bar absolute (0 psi gauge) Inlet

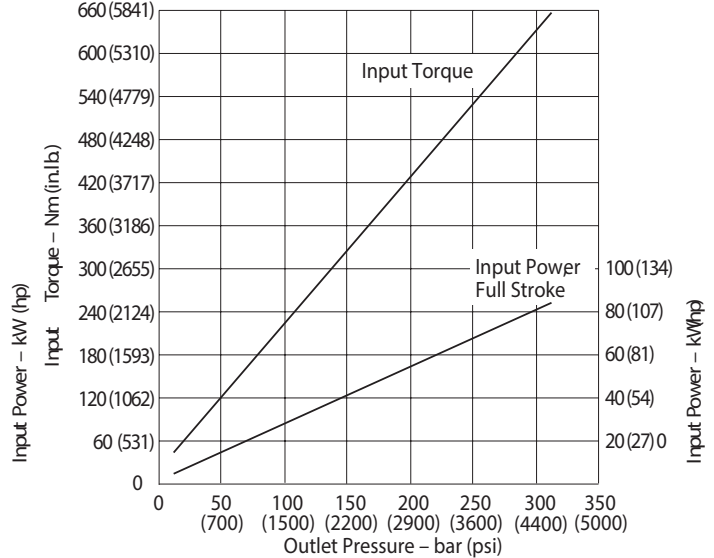

# Performance

Quiet version, optimized for 1000-1800 rpm (E) PVM131

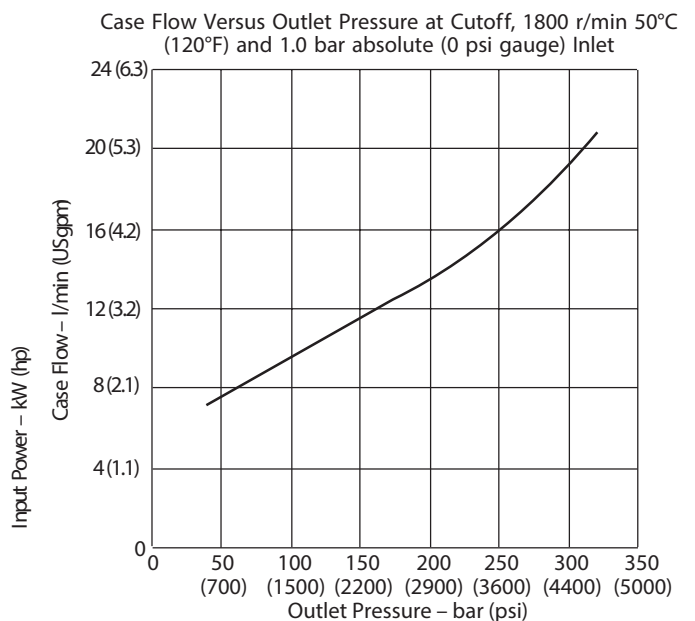
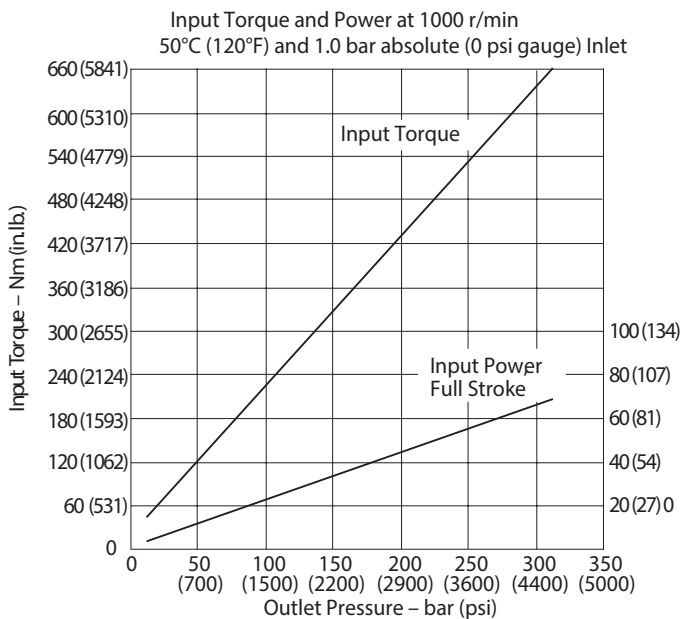
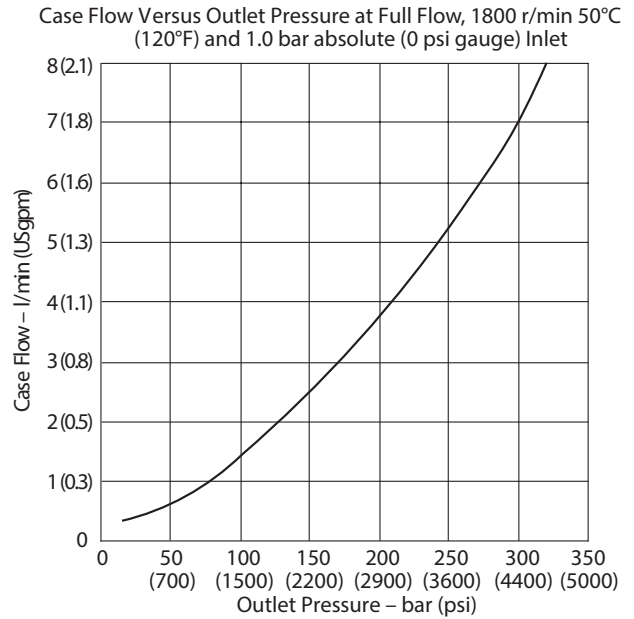
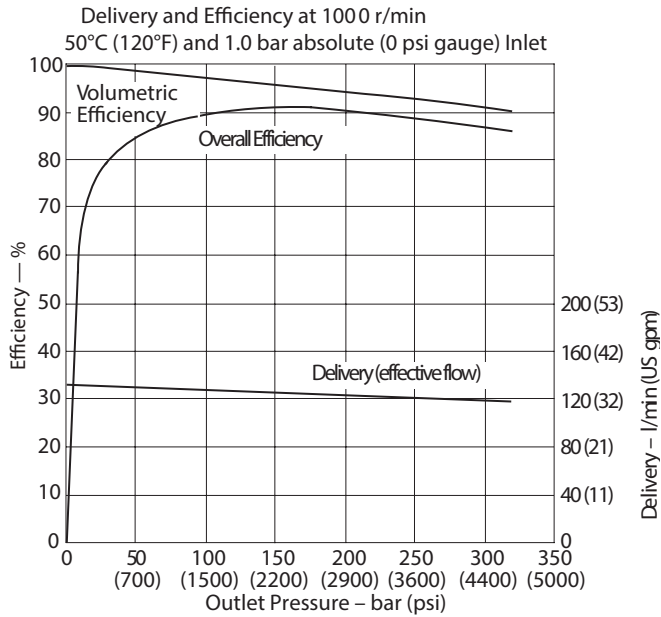

# Performance

Higher speed version (M)PVM131

Typical Noise Levels at 2000 and 600 r/min with petroleum oil (10 W) @ 93°C (200°F) and 1.0 bar absolute (0 psi gauge) inlet

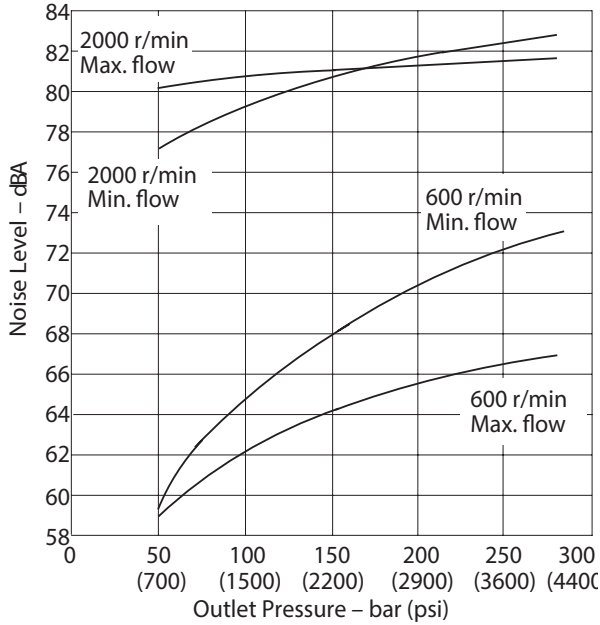

Delivery and Case Flow Versus Speed @ 93°C (200°F), full flow and .0 bar absolute (0 psi) gauge Inlet

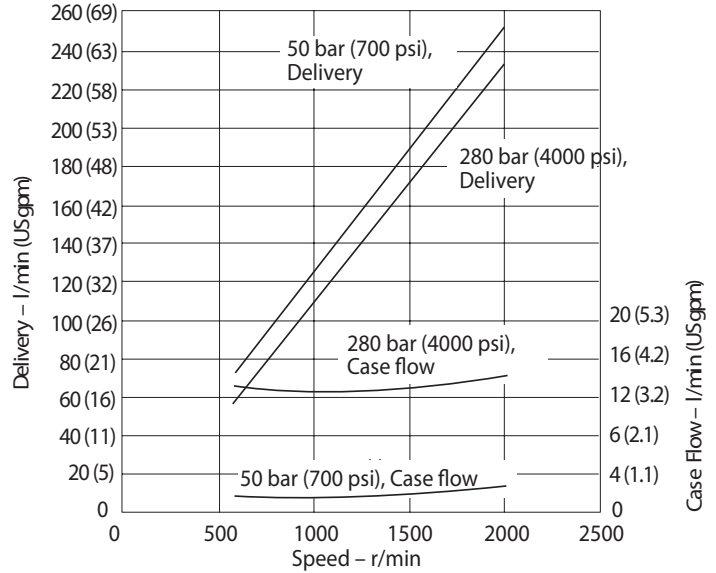

Sound pressure data equivalent to NFPA

Overall Efficiency Versus Speed @ 93°C (200°F) and 1.0 bar absolute (0 psi gauge) inlet

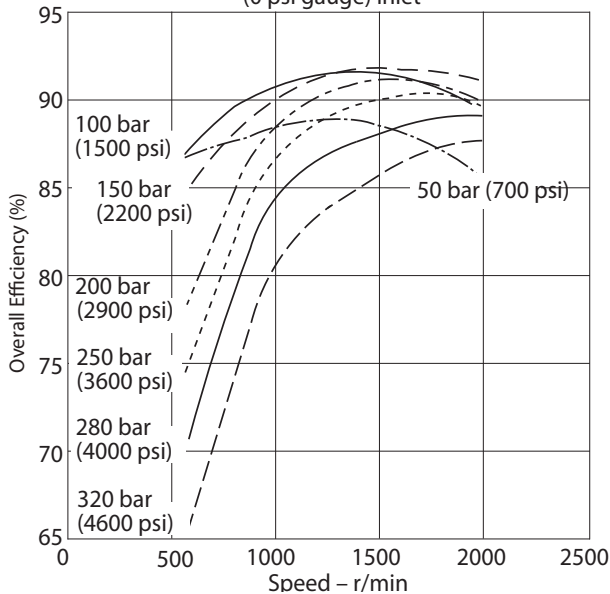

Input Torque Versus Speed @ 93°C (200°F), full flow and 1.0 bar absolute (0 psi gauge) inlet

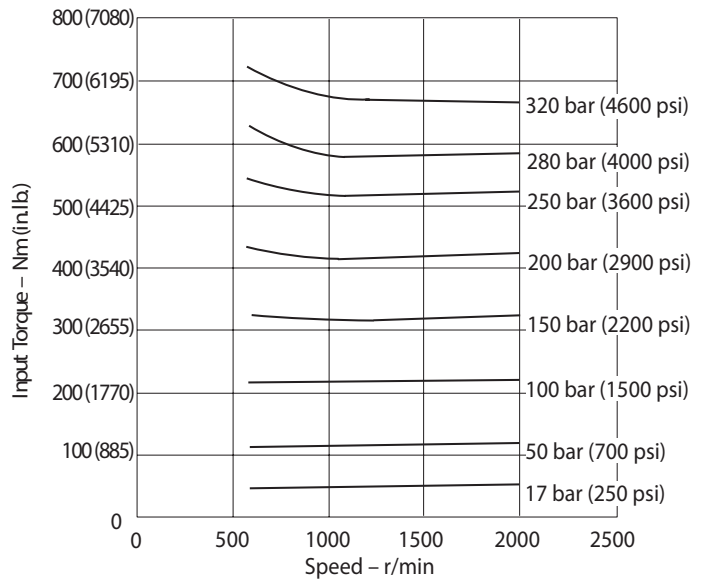



# Performance

Higher speed version (M)PVM131

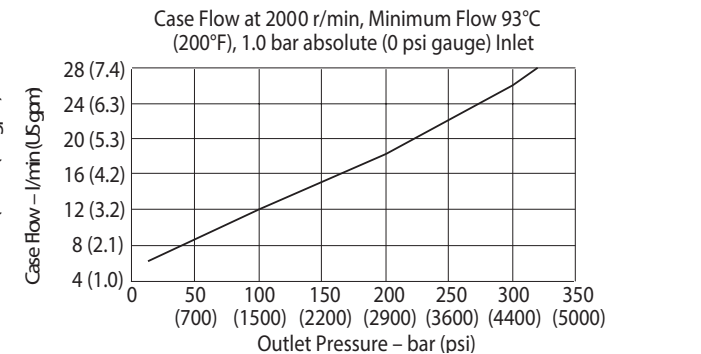
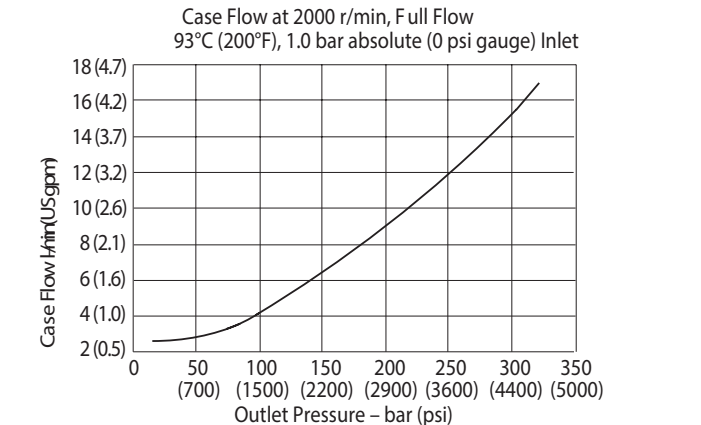
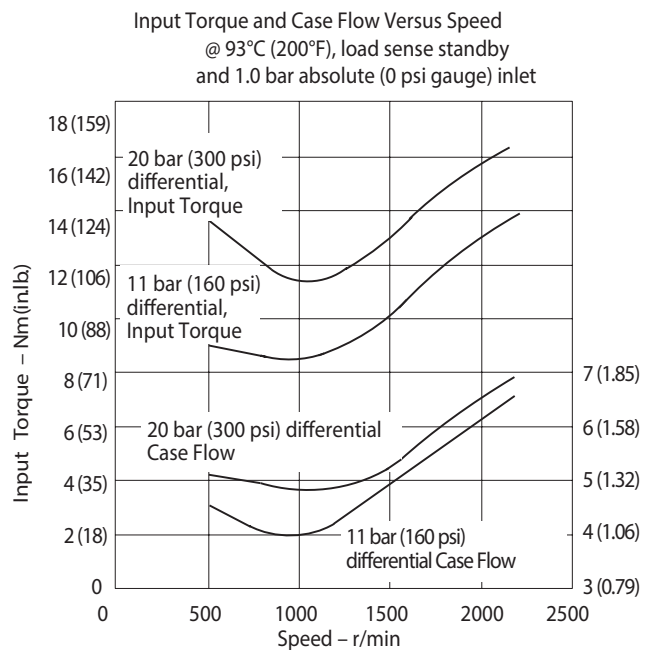
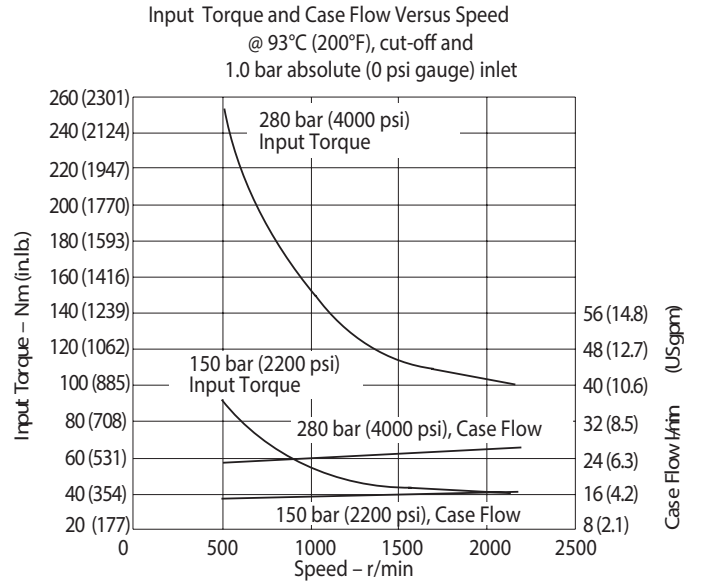
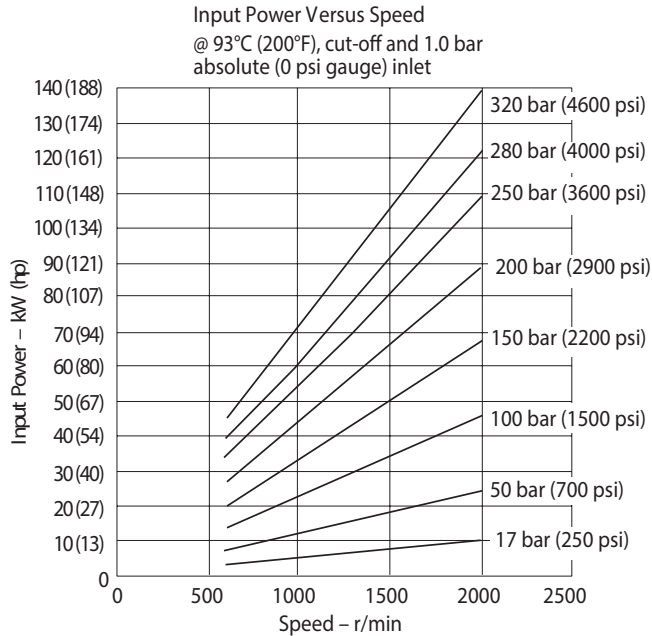

# Performance

Quiet version, optimized for 1000-1800 rpm (E) PVM141

Typical Noise Levels at 1800 and 1200 r/min with Petroleum Oil (10W) at 50°C (120°F) and 1.0 bar absolute (0 psi gauge) Inlet

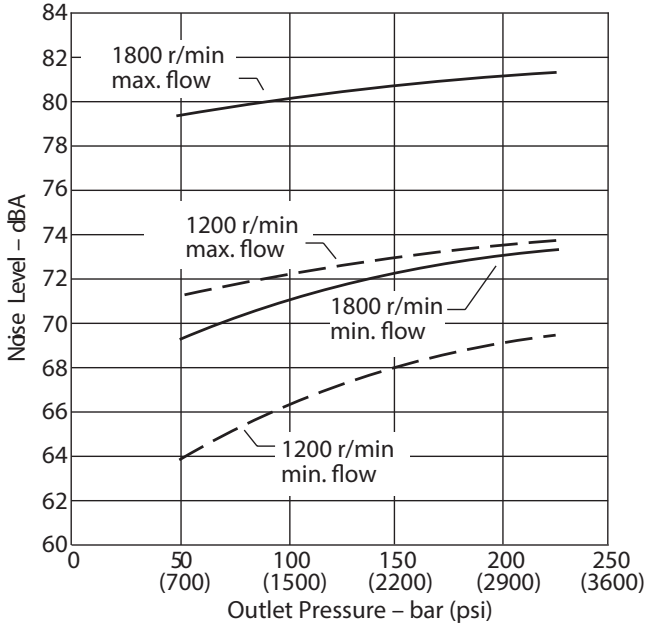

Delivery and Efficiency at 1800 r/min, 50C (120F), and 1.0 bar absolute (0 psi gauge) Inlet

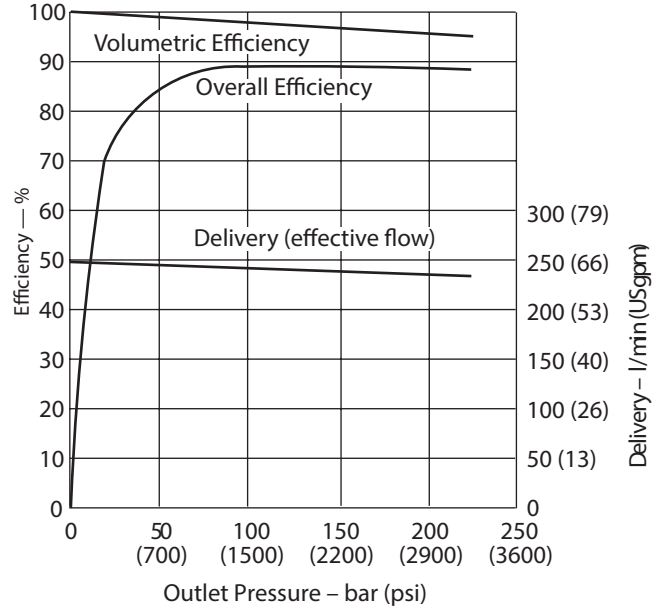

Typical Noise Levels 1500 and 1000 r/min with Petroleum Oil (10W) at 50°C (120°F) and 1.0 bar absolute (0 psi gauge) Inlet

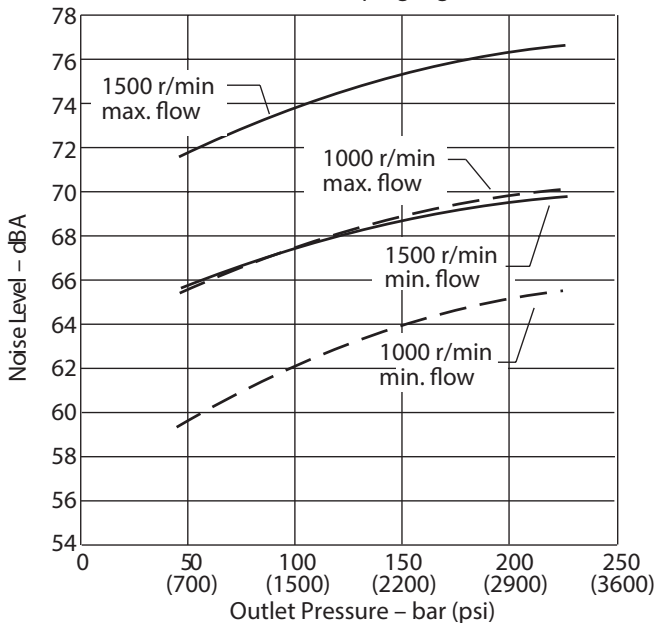

Input Torque and Power at 1800 r/min, 50C (120F), and 1.0 bar absolute (0 psi gauge) Inlet

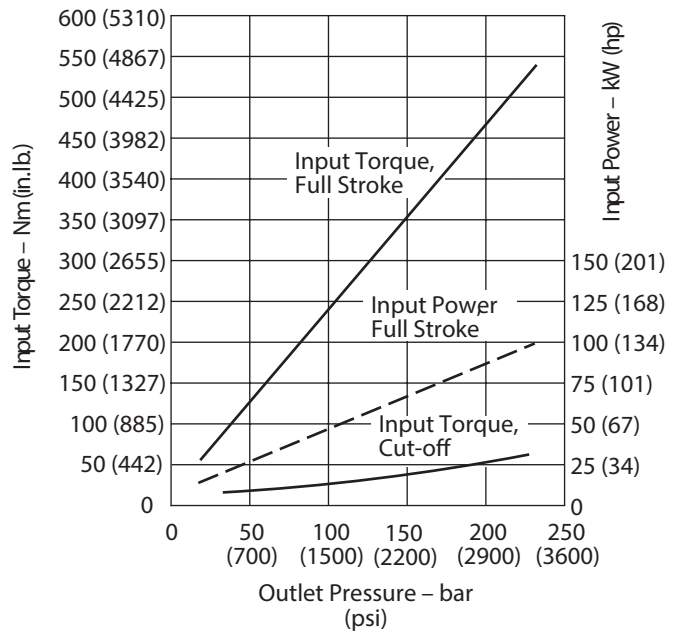

Sound pressure data equivalent to NFPA.

# Performance

Quiet version, optimized for 1000-1800 rpm (E) PVM141

Delivery and Efficiency at 1500 r/min, 50C (120F), and 1.0 bar absolute (0 psi gauge) Inlet

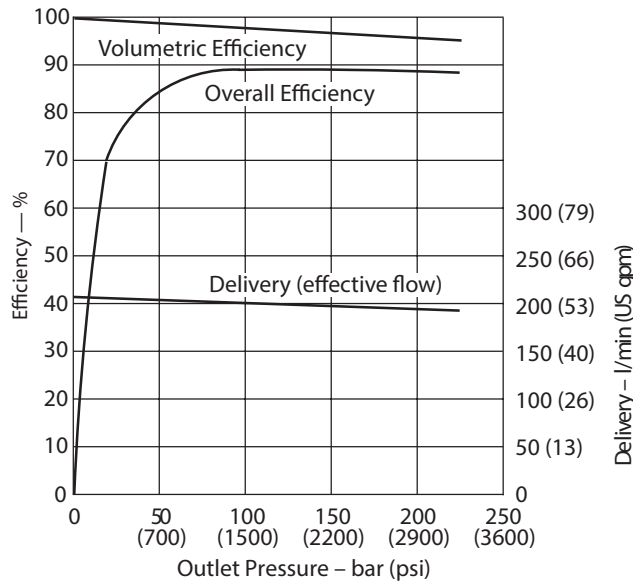

Delivery and Efficiency at 1200 r/min, 50C (120F), and 1.0 bar absolute (0 psi gauge) Inlet

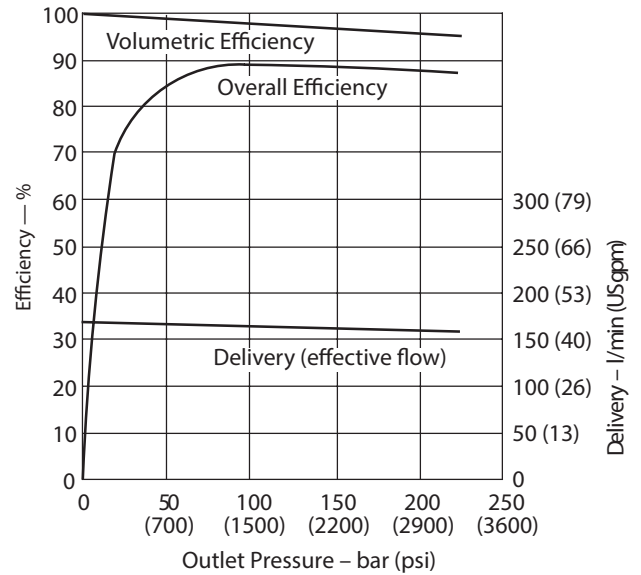

Input Torque and Power at 1500 r/min, 50C (120F), and 1.0 bar absolute (0 psi gauge) Inlet

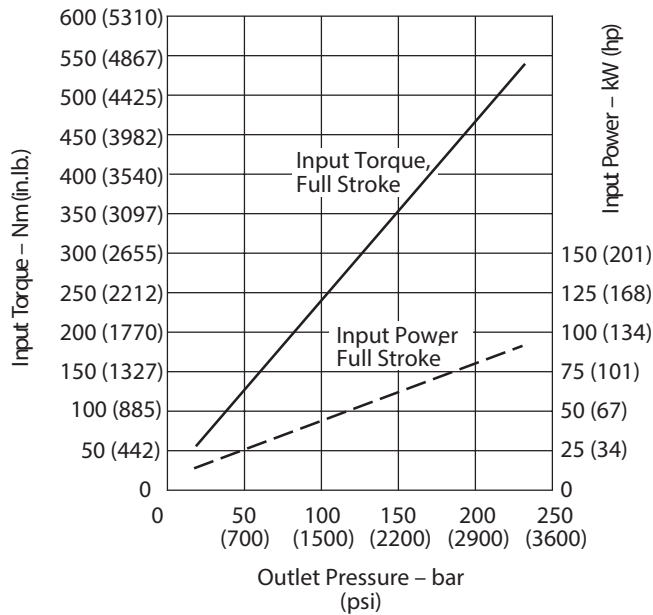

Input Torque and Power at 1200 r/min, 50C (120F), and 1.0 bar absolute (0 psi gauge) Inlet

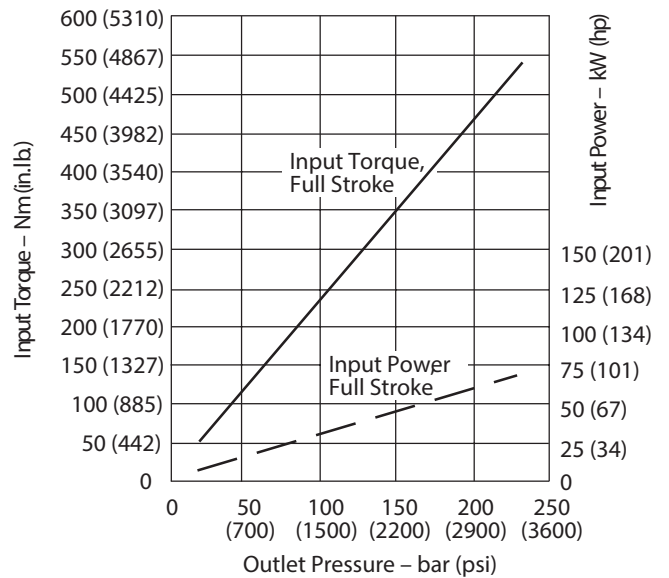

# Performance

Quiet version, optimized for 1000-1800 rpm (E) PVM141

Delivery and Efficiency at 1000 r/min, 50C (120F), and 1.0 bar absolute (0 psi gauge) Inlet

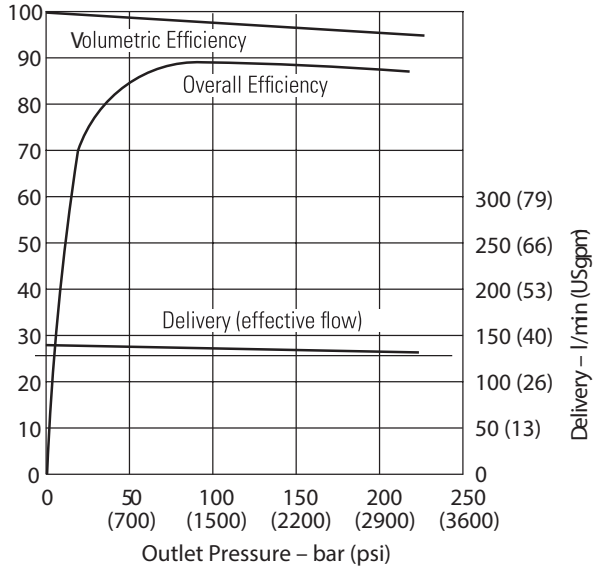

Case Flow Versus Outlet Pressure at Full Flow, 1800 r/min 50°C (120°F) and 1.0 bar absolute (0 psi gauge) Inlet

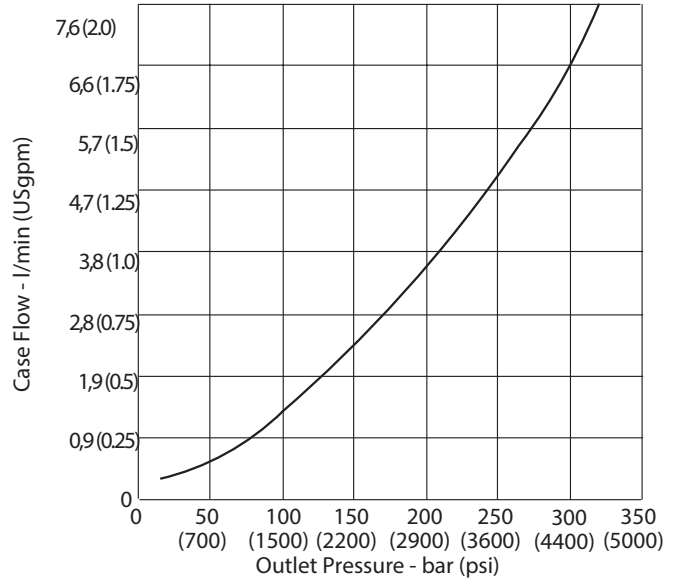

Input Torque and Power at 1000 r/min, 50C (120F), and 1.0 bar absolute (0 psi gauge) Inlet

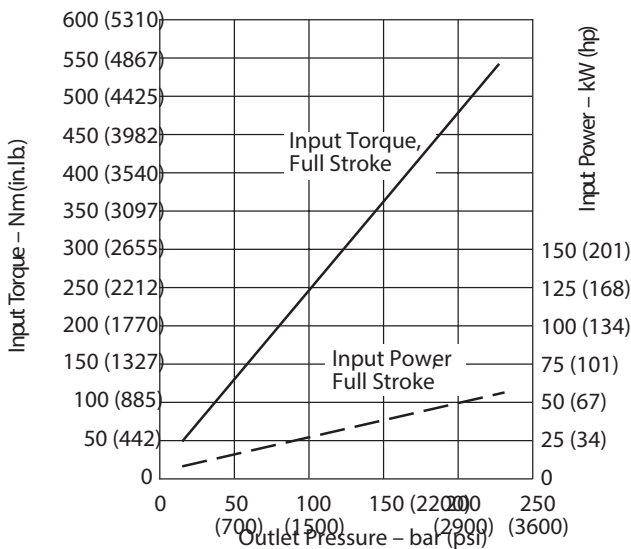

Case Flow Versus Outlet Pressure at Cut off, 1800 r/min 50°C (120°F) and 1.0 bar absolute (0 psi gauge) Inlet 22,7 (6)

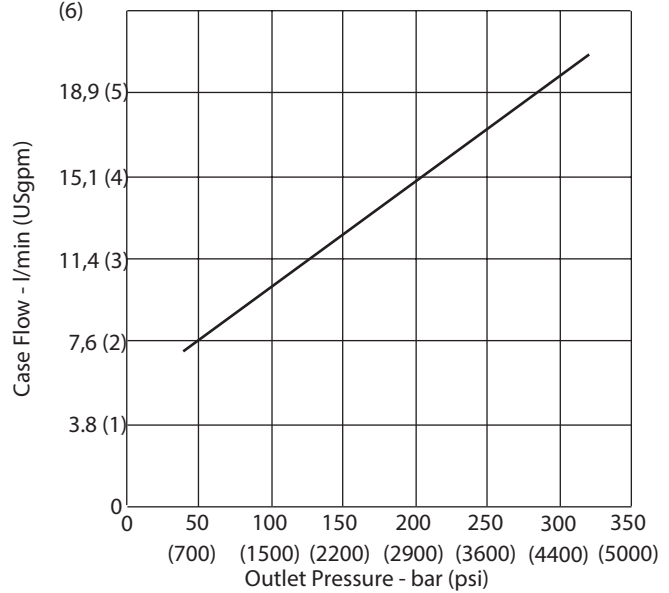

# Performance

Higher speed version (M)PVM141

Typical Noise Levels at 2000 and 1000 r/min with Petroleum Oil (10W) at 93°C (200°F), and 1.0 bar absolute (0 psi gauge) Inlet

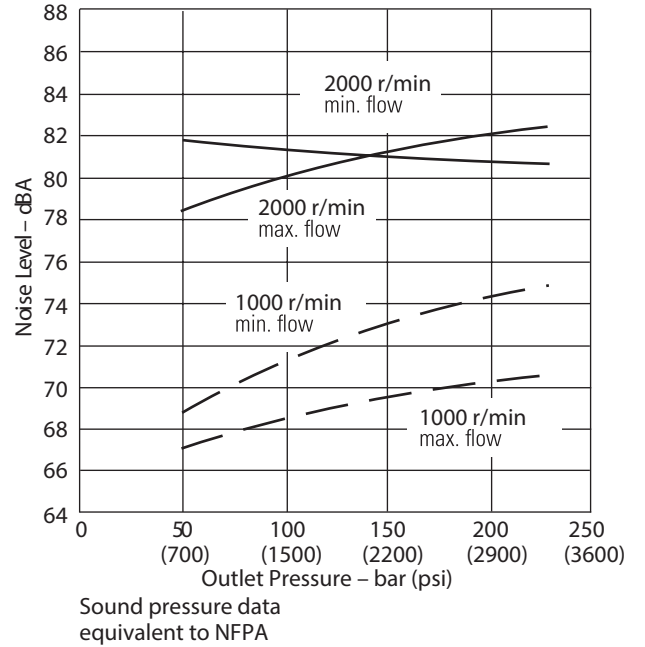

Overall Efficiency versus Speed at 93°C (200°F), and 1.0 bar absolute (0 psi gauge) Inlet

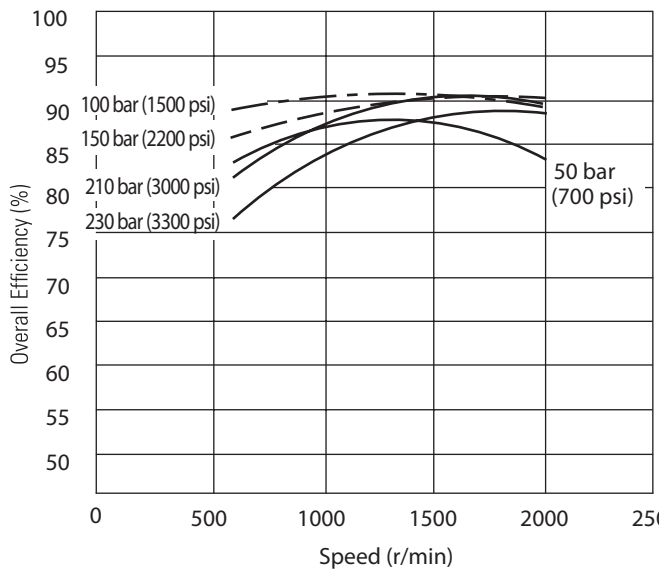

Delivery and Case Flow versus Speed at 93°C (200°F), Full Flow and 1.0 bar absolute (0 psi gauge) Inlet

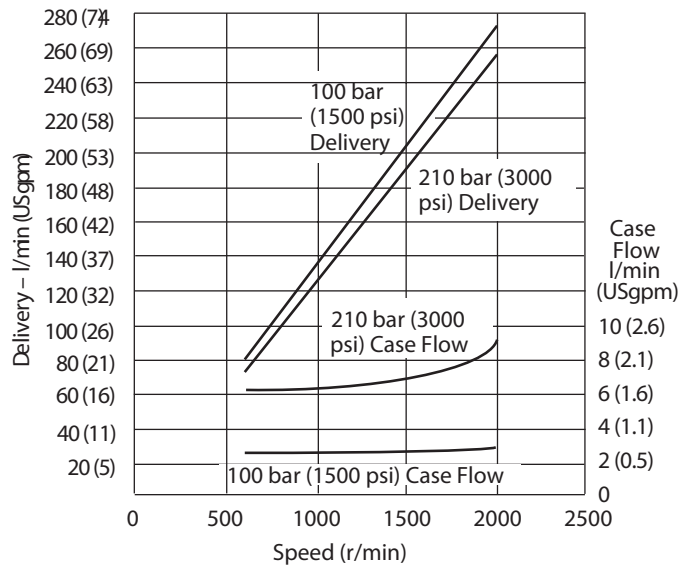

# Performance

Higher speed version (M)PVM141

Input Torque versus Speed at 93°C (200°F), Full Flow and 1.0 bar absolute (0 psi gauge) Inlet

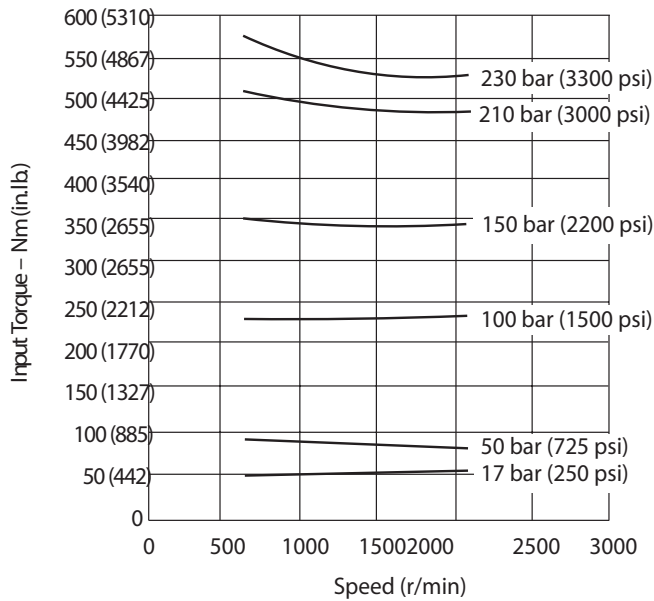

Input Power versus Speed, 93°C (200°F), and 1.0 bar absolute (0 psi gauge) Inlet

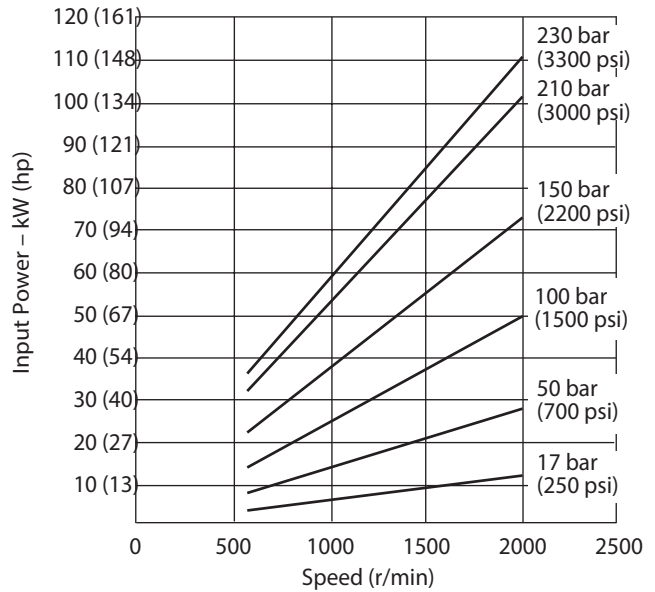

Input Torque and Case Flow versus Speed at 93°C (200°F), Load Sense Standby and 1.0 bar absolute (0 psi gauge) Inlet

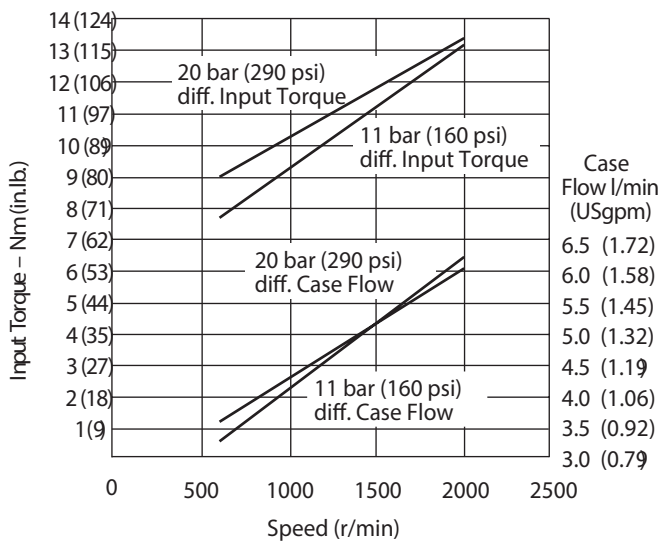

Input Torque and Case Flow versus Speed at 93°C (200°F), Pressure Limit Cut-Off and 1.0 bar absolute (0 psi gauge) inlet

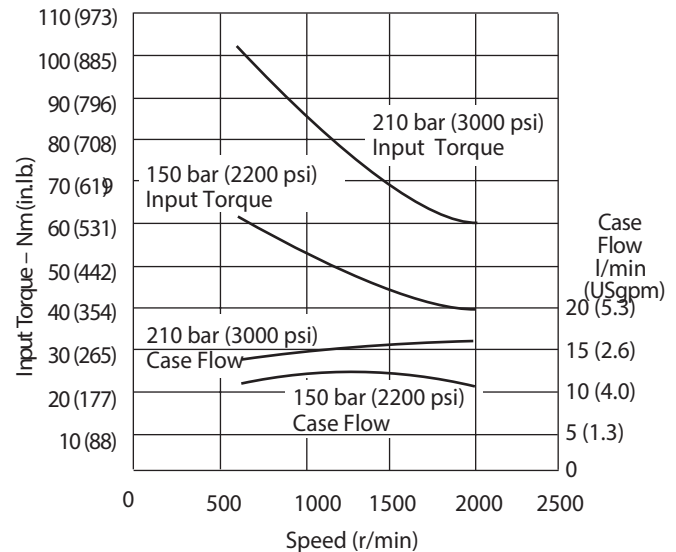

# End-ported Models

PVM018/020

Dimensions in millimeters (inches)

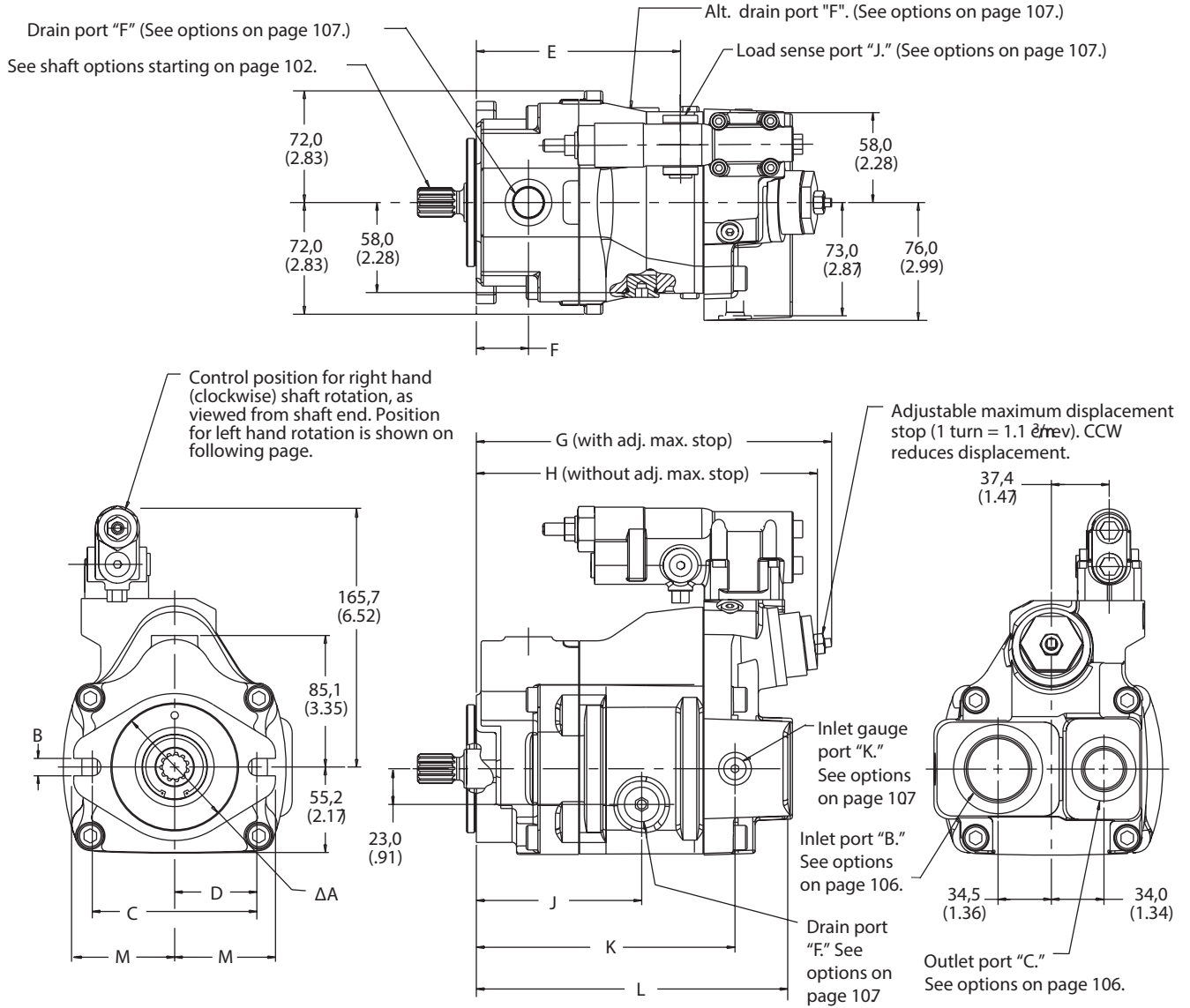

# End-ported Models

PVM018/020

Dimensions in millimeters (inches)

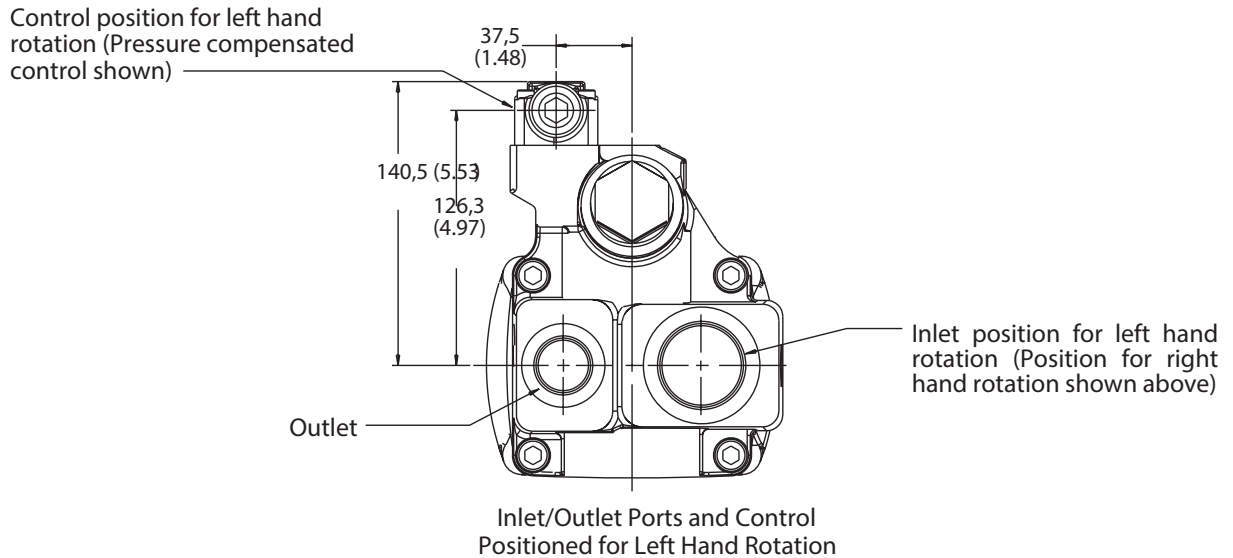
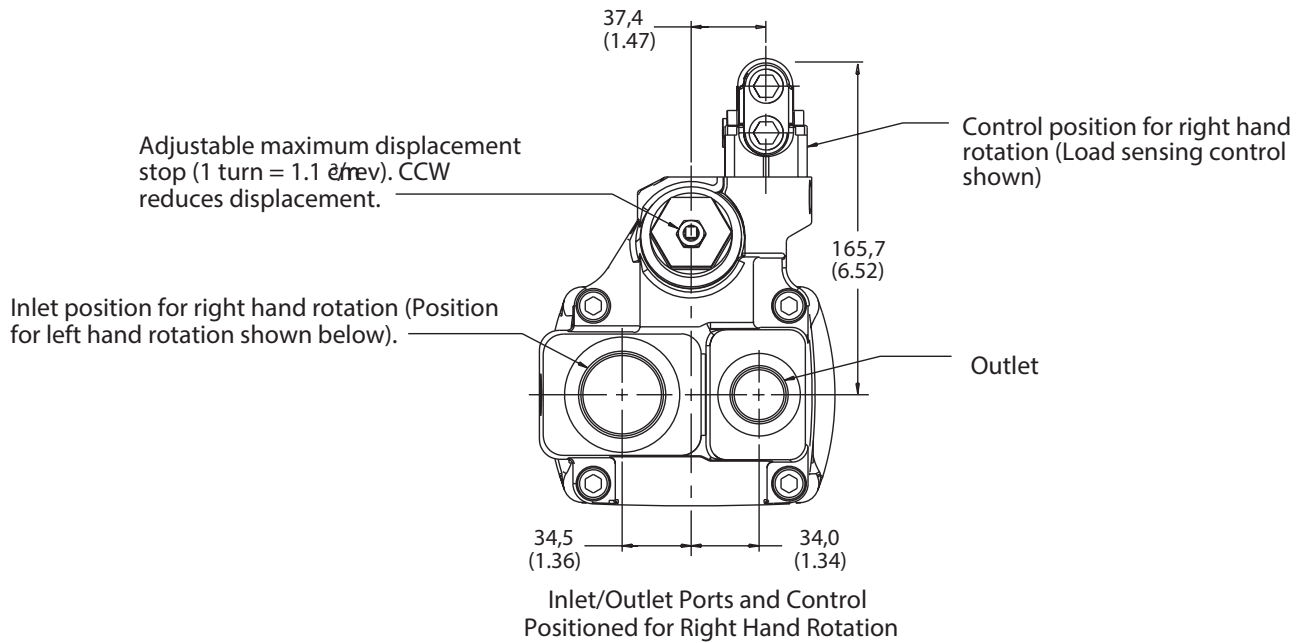



# Side-ported Models

PVM018/020

Dimensions in millimeters (inches)

Load sense port "J"

(See options on page 107)

Alt. drain port "F"

(See options on page 107)

Drain port "F"

(See options on page 107)

See shaft options starting on page 102.

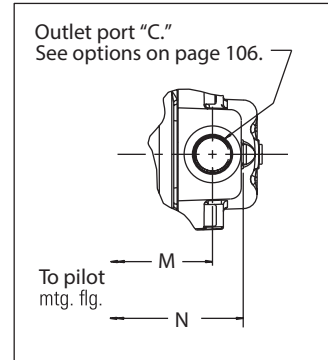
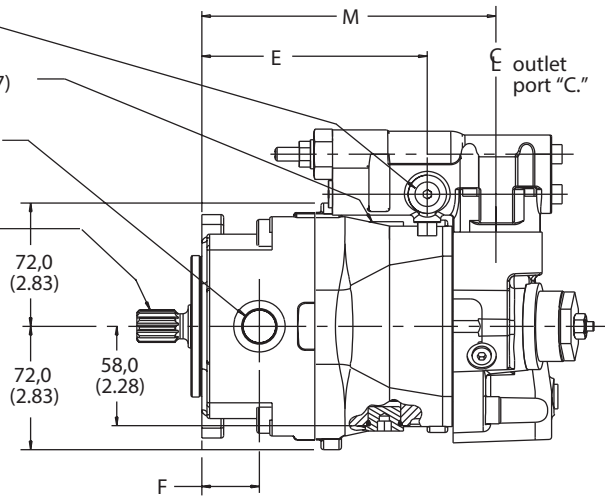

Control position for right hand (clockwise) shaft rotation, as viewed from shaft end. Position for left hand rotation is shown on following page.

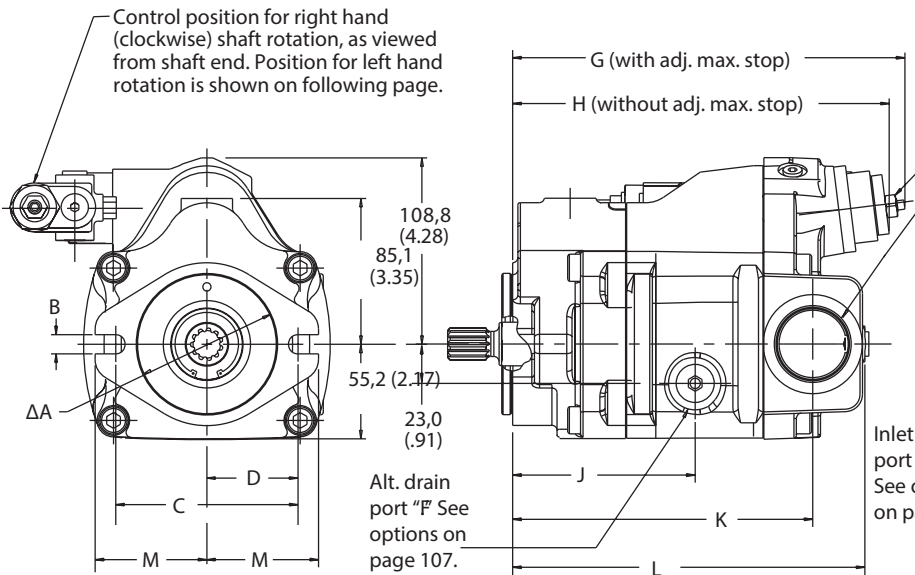

Adjustable maximum displacement stop (1 turn = 1.1°cm / rev). CCW reduces displacement.

Outlet port "C." (above). See options on page 106.

Inlet port "B." See options on page 106.

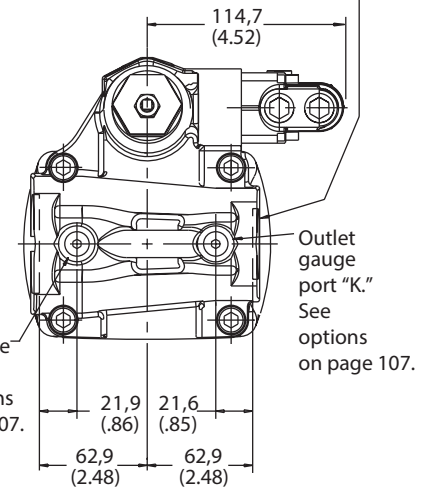

# Side-ported Models

PVM018/020

Dimensions in millimeters (inches)

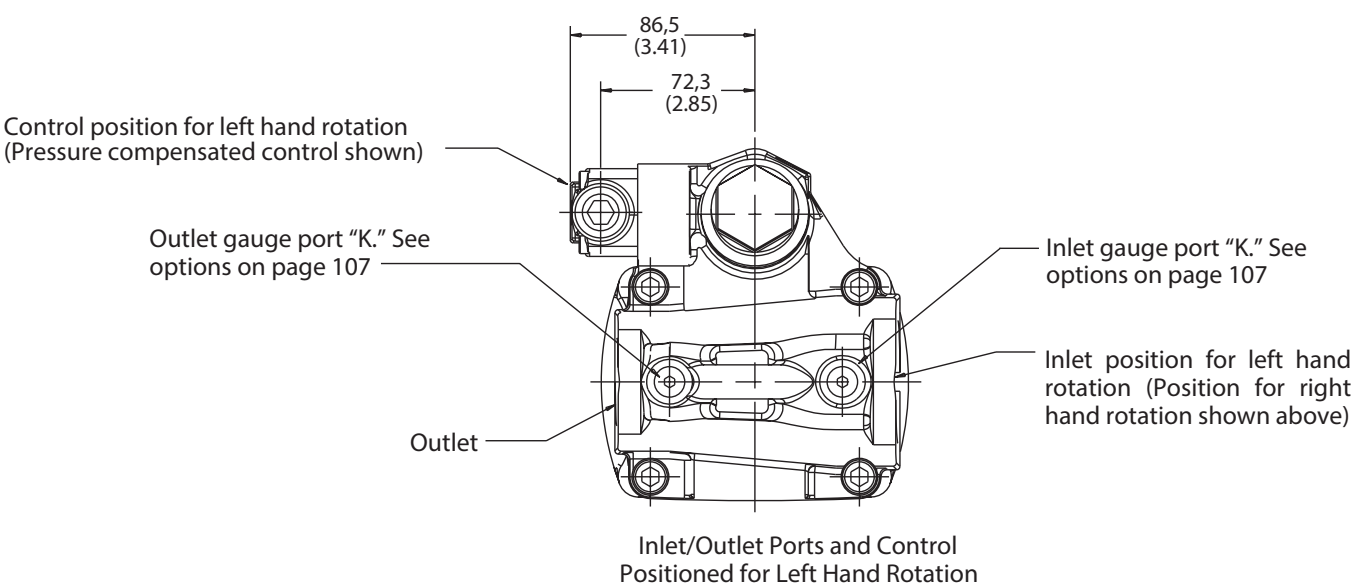
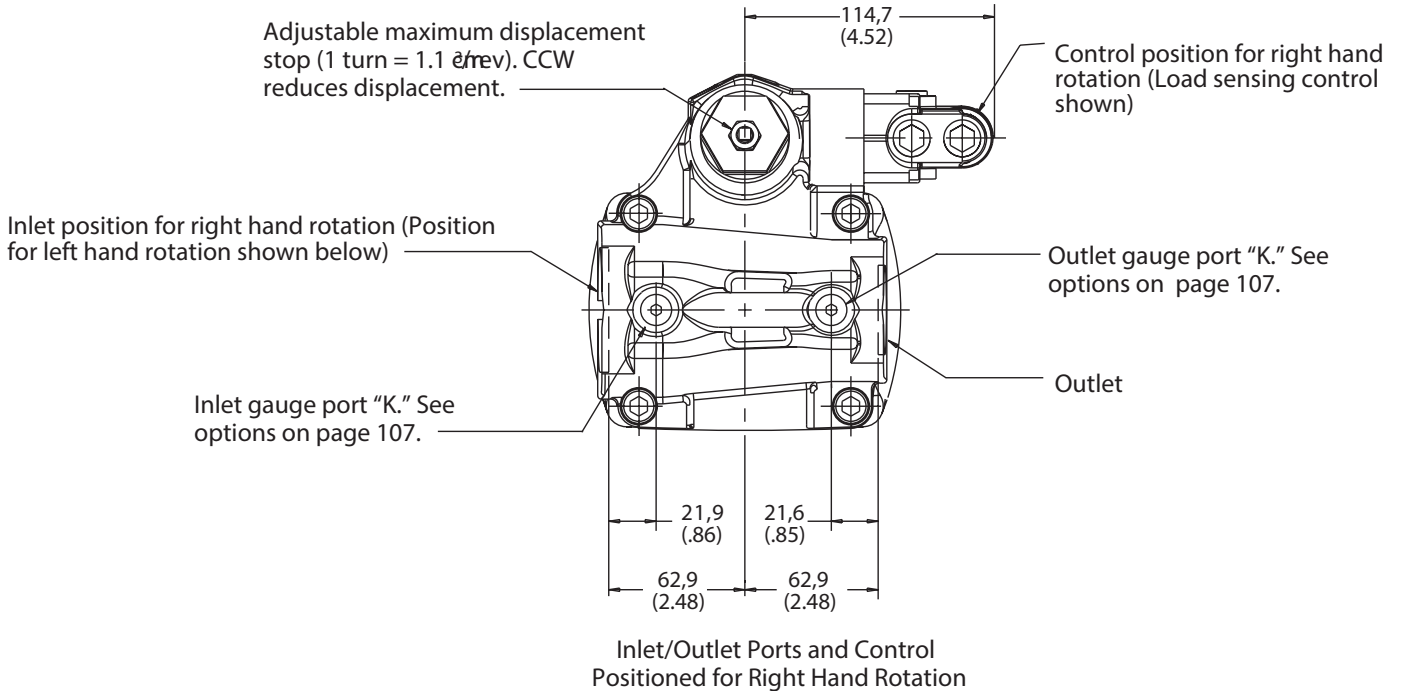

# Thru-drive Models

PVM018/020

Dimensions in millimeters (inches)

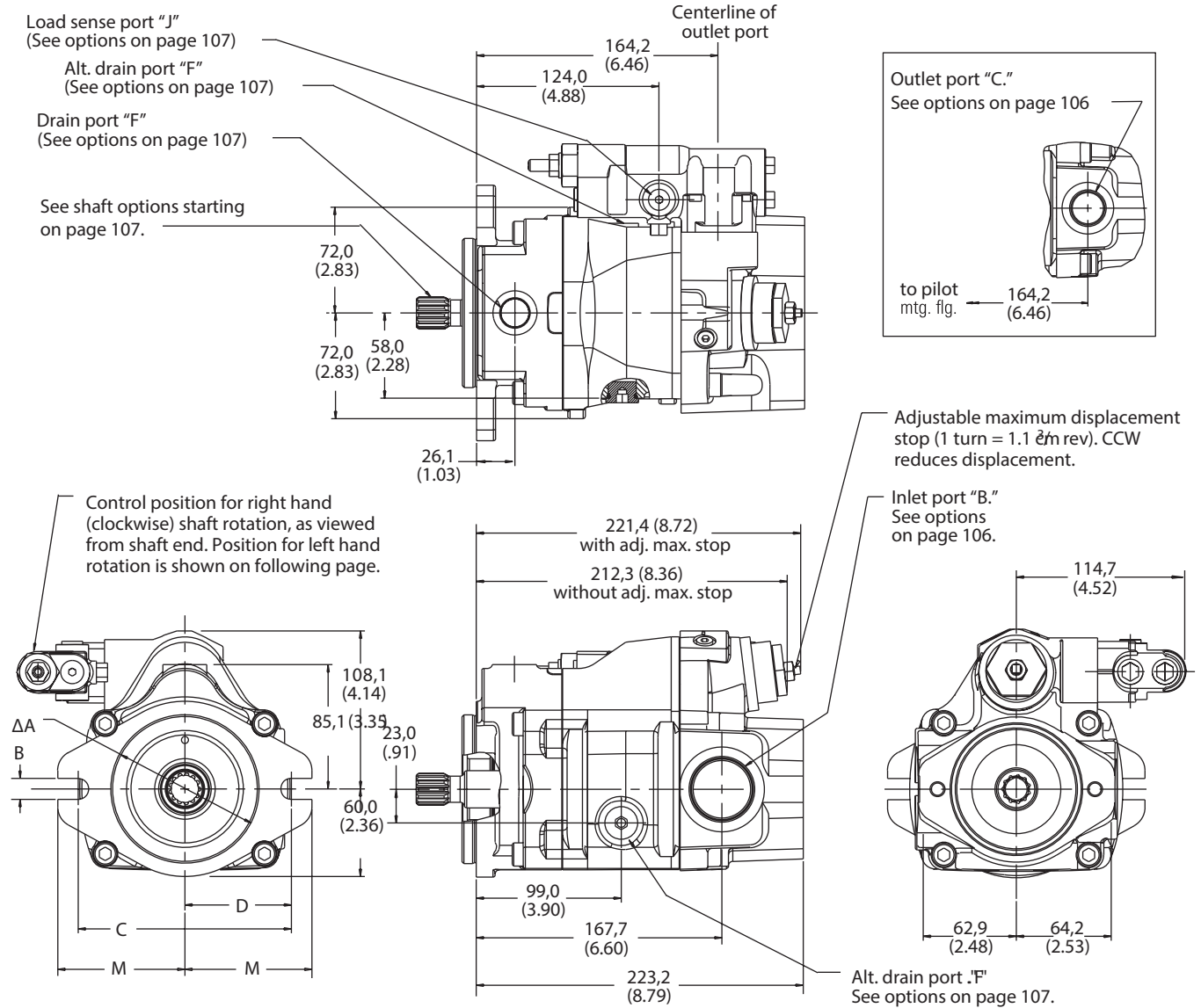

# Thru-drive Models

PVM018/020

## Model Code Position 25 Description

A	For SAE "A" pad with a 9T, 16/32 DP, 30° pressure angle, involute spline
B	For SAE "A" pad with a 11T, 16/32 DP, 30° pressure angle, involute spline
G	For ISO 80 A2HW pad with a 9T SAE spline
H	For ISO 80 A2HW pad with a 11T SAE spline

Dimensions in millimeters (inches)

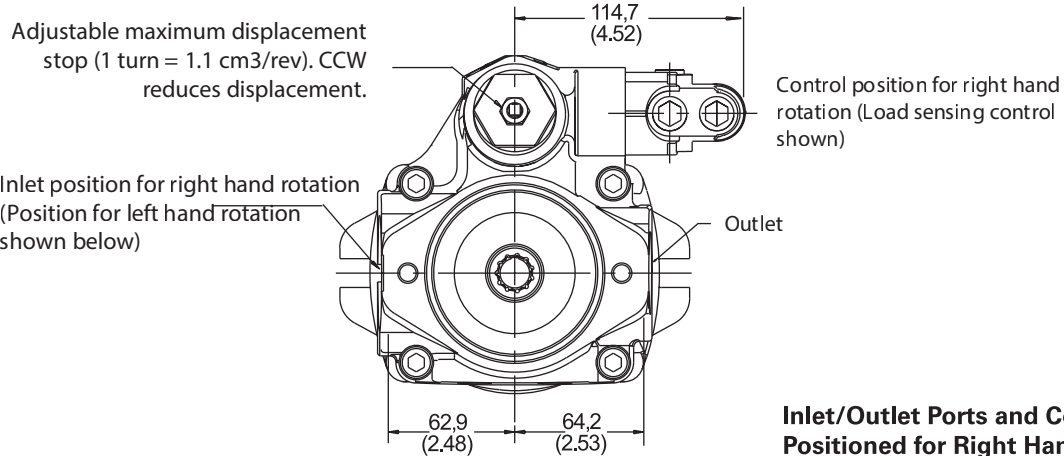

**Inlet/Outlet Ports and Control Positioned for Right Hand Rotation**

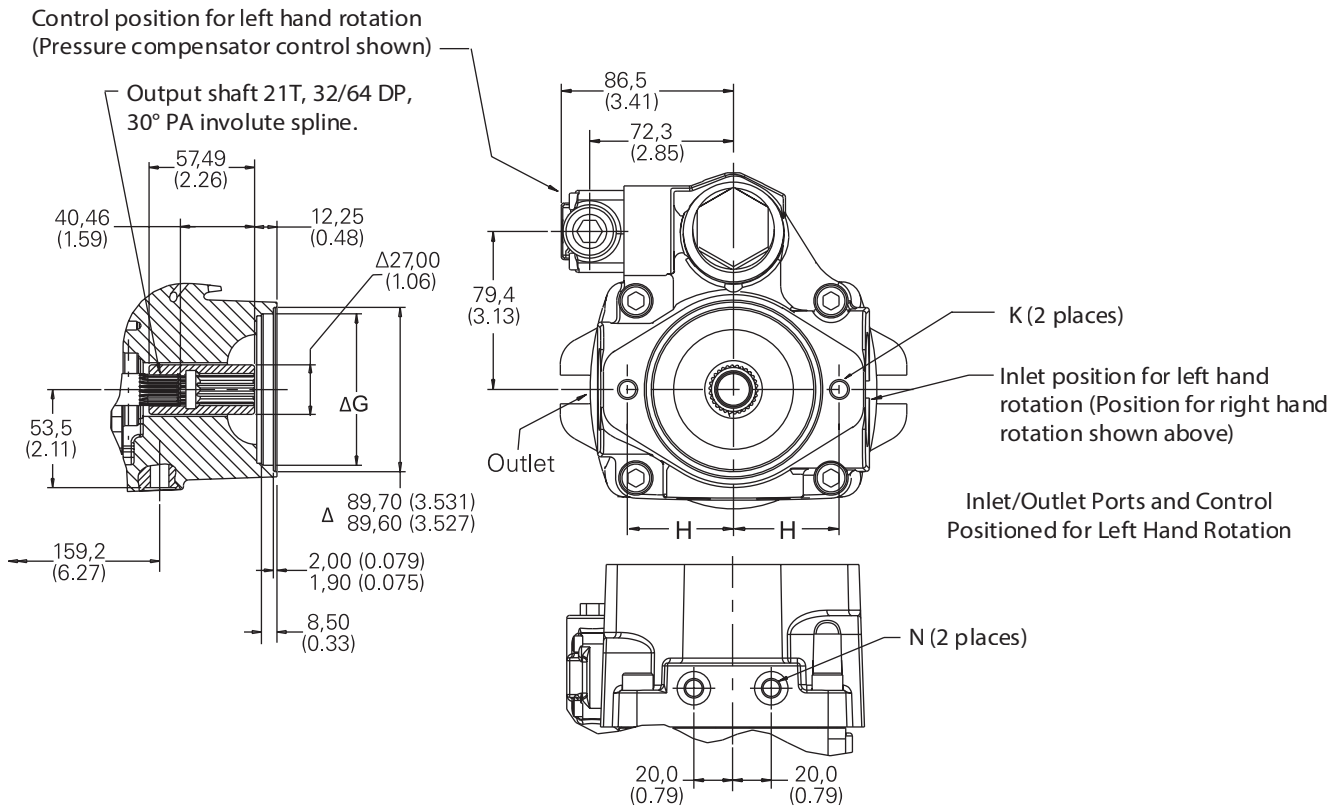

**Inlet/Outlet Ports and Control Positioned for Left Hand Rotation**

Model Code Position 25	ØG	H	K	N
A,B	82,625 (3.253) 82,575 (3.251)	53,2 (2.09)	375-16 UNC-2B thd. 0.75 deep min	375-16 UNC-2B thd. 0.62 deep min.
G,H	80,046 (3.151) 80,002 (3.150)	54,5 (2.15)	M10 x 1,50 thd. 19,05 deep min	M10 x 1,50 thd. 15,88 deep min.

# Flange Designations

PVM018/020

"A" Pilot Flange Designation	ØA	B	C	D	E	F	G	H	J	K	L	M
SAE J744-82-2 Model Code A	82,55 (3.25)	11,35/10,97 (.447/.432)	106,4 (4.19)	53,2 (2.09)	131,5 (5.18)	33,6 (1.32)	228,9 (9.00)	219,8 (8.65)	106,5 (4.19)	166,7 (6.56)	200,7 (7.90)	65,2 (2.57)
ISO 3019/2-80A2HW Model Code B	80,00 (3.15)	11,27/11,00 (.444/.433)	109,0 (4.29)	54,5 (2.15)								

"B" Pilot Flange Designation	ØA	B	C	D	E	F	G	H	J	K	L	M
SAE J744-101-2 Model Code C	101,60 (4.00)	14,55/14,17 (.572/.557)	146,0 (5.750)	73,0 (2.875)	124,0 (4.88)	26,1 (1.03)	221,4 (8.72)	212,3 (8.36)	99,0 (3.90)	159,2 (6.27)	193,9 (7.63)	87,0 (3.43)
ISO 3019/2-100A2HW Model Code D	100,00 (3.937)	14,27/14,00 (.562/.551)	140,0 (5.512)	70,0 (2.756)								

Pilot Flange Designation	ØA	B	C	D
SAE J744-127-2 Model Code C	101,60 (4.00)	14,55/14,17 (.572/.558)	146,0 (5.75)	73,0 (2.87)
ISO 3019/2-100 A2HW Model Code D	100,00 (3.94)	14,27/14,00 (.562/.551)	140,0 (5.51)	70,0 (2.76)

# End-ported Models

PVM045/050

Dimensions in millimeters (inches)

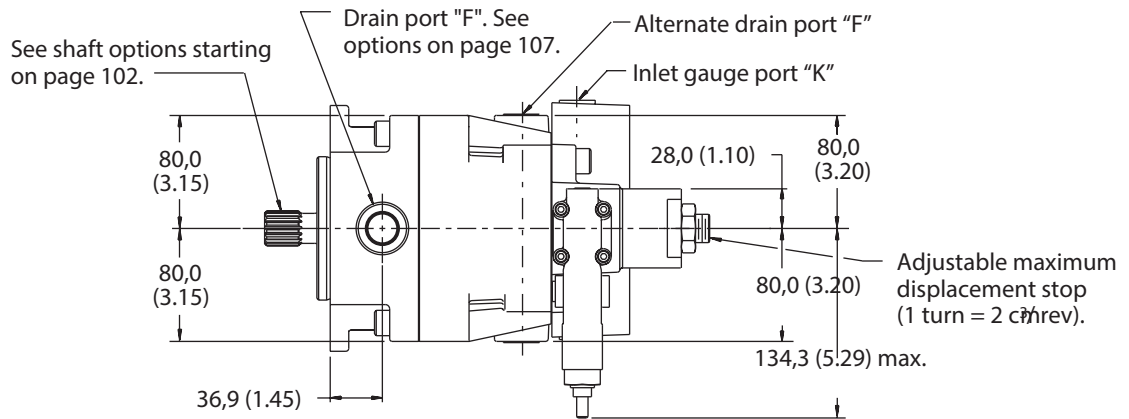

Control position for left hand (counterclockwise) shaft rotation, as viewed from shaft end. Position for right hand rotation is shown on following page.

Load sensing control (See pressure compensated control on following page.)

Load sense port "J." See options on page 107.

Inlet port "B." See options on page 106.

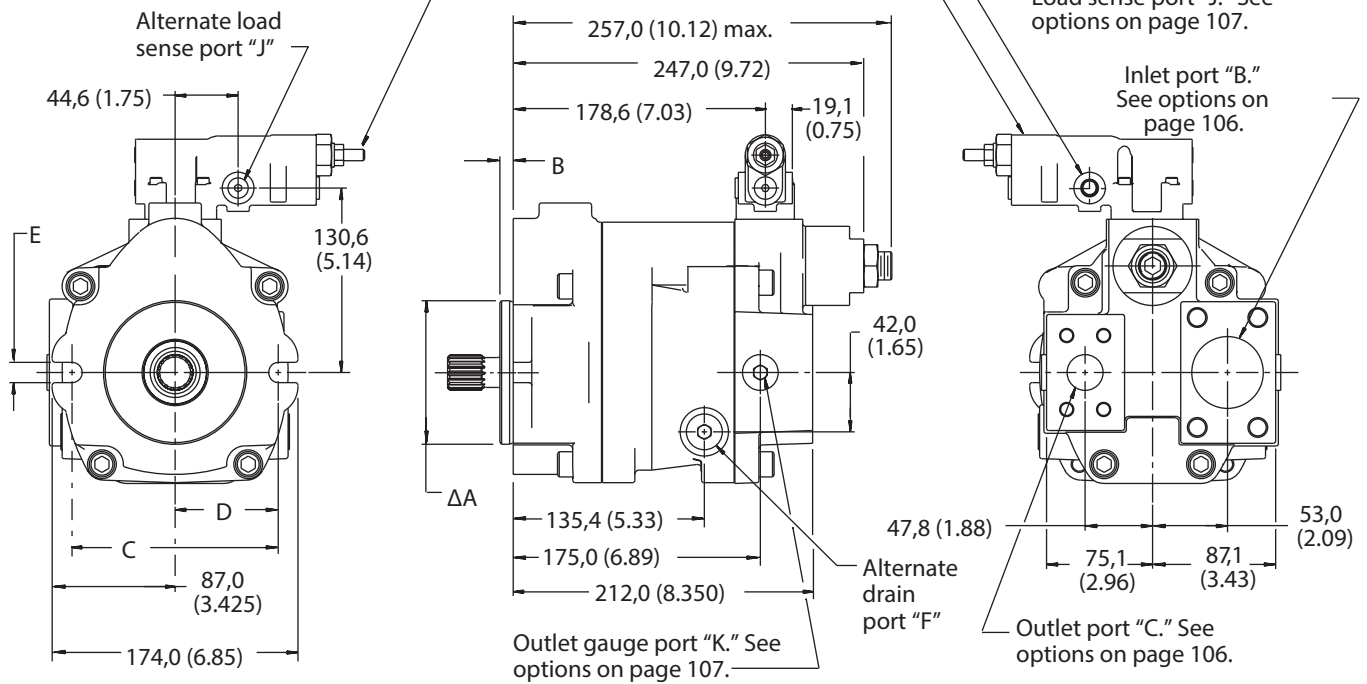

# End-ported Models

PVM045/050

Dimensions in millimeters (inches)

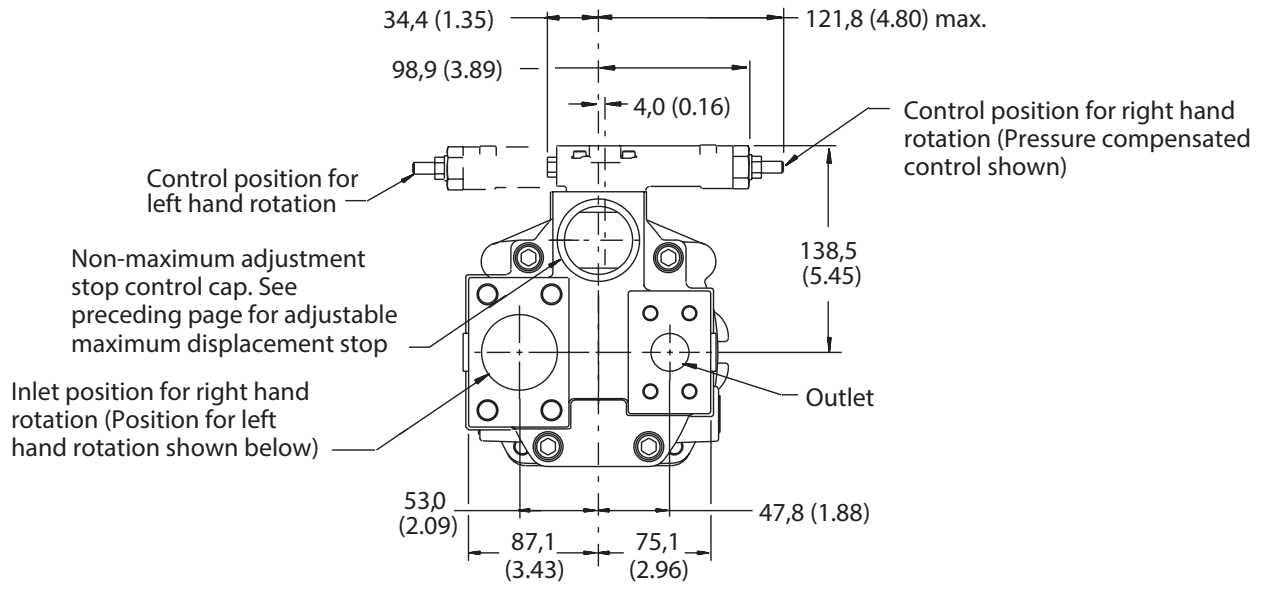

Inlet/Outlet Ports and Control Positioned for Right Hand Rotation

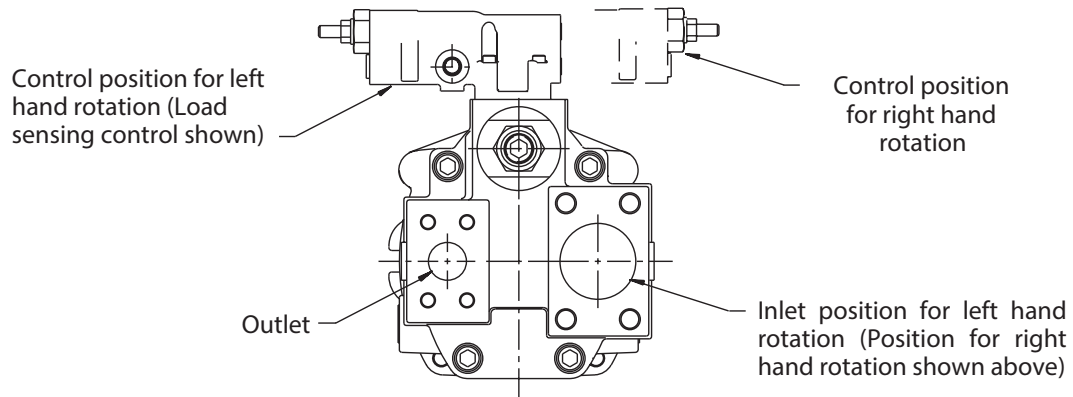

Inlet/Outlet Ports and Control Positioned for Left Hand Rotation  
Dimensions shown on preceding page.

# Side-ported Models

PVM045/050

Dimensions in millimeters (inches)

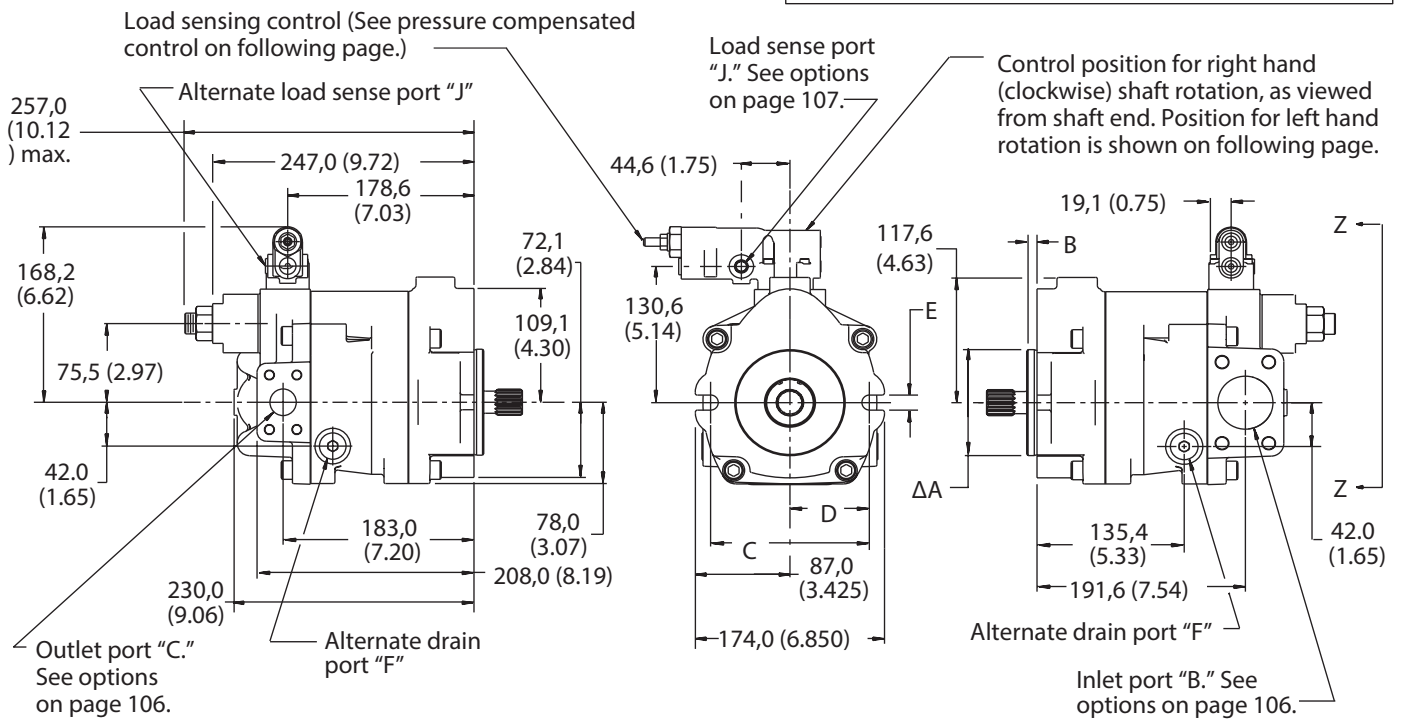
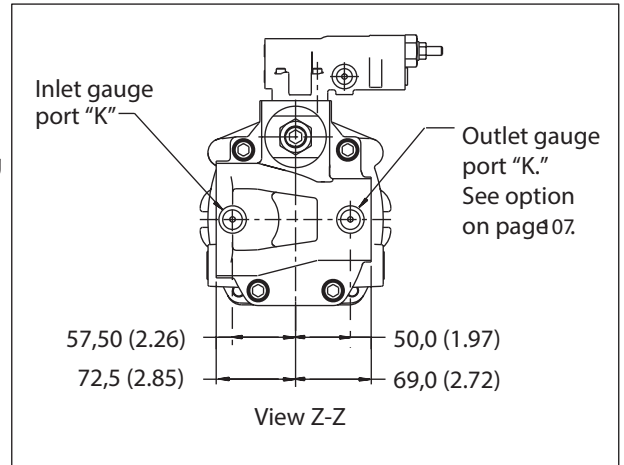
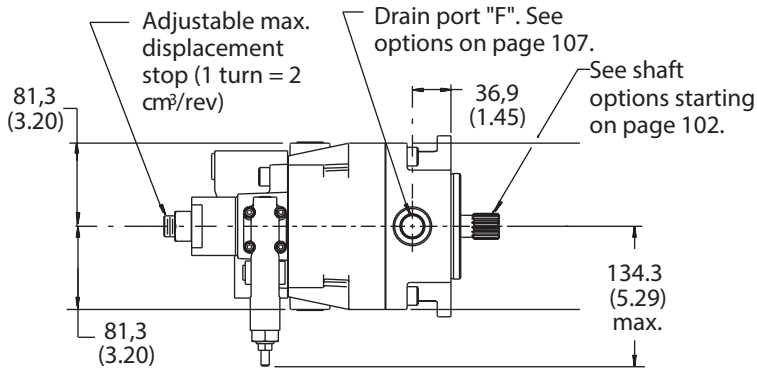



# Side-ported Models

PVM045/050

Dimensions in millimeters (inches)

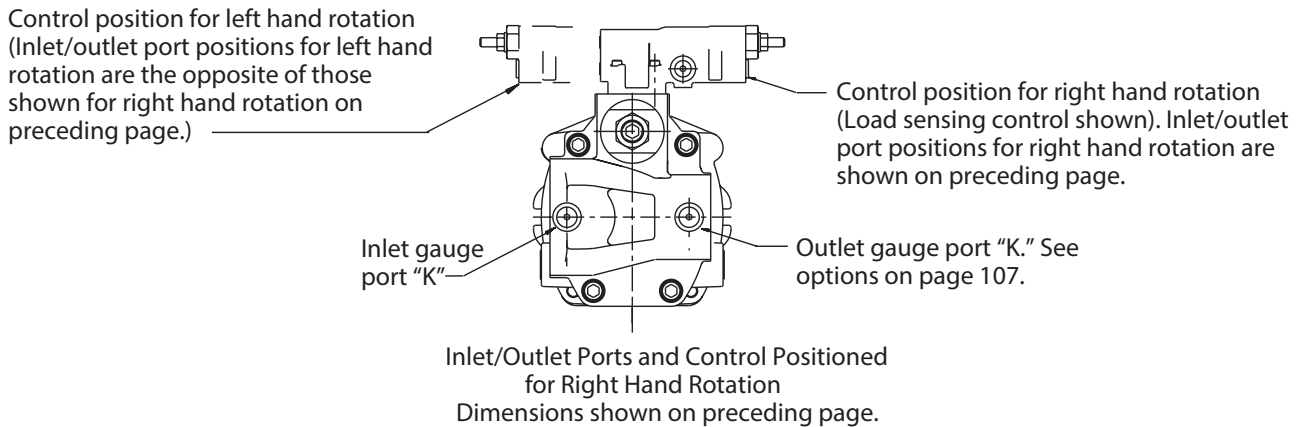
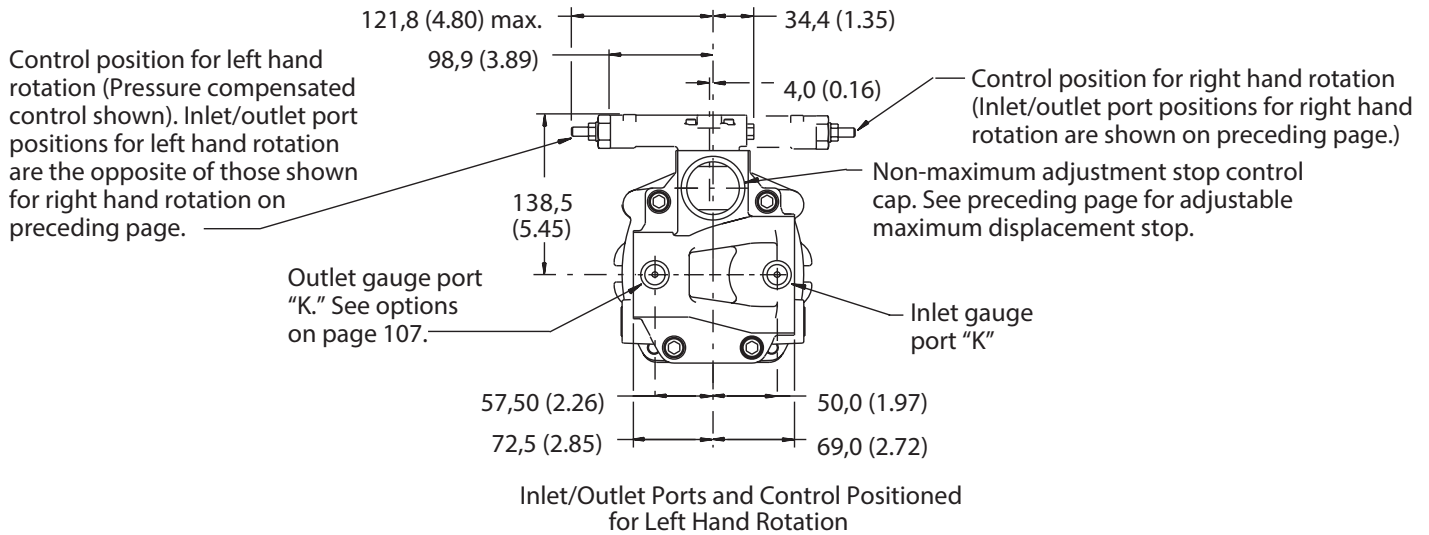

# Thru-drive Models

PVM045/050

Dimensions in millimeters (inches)

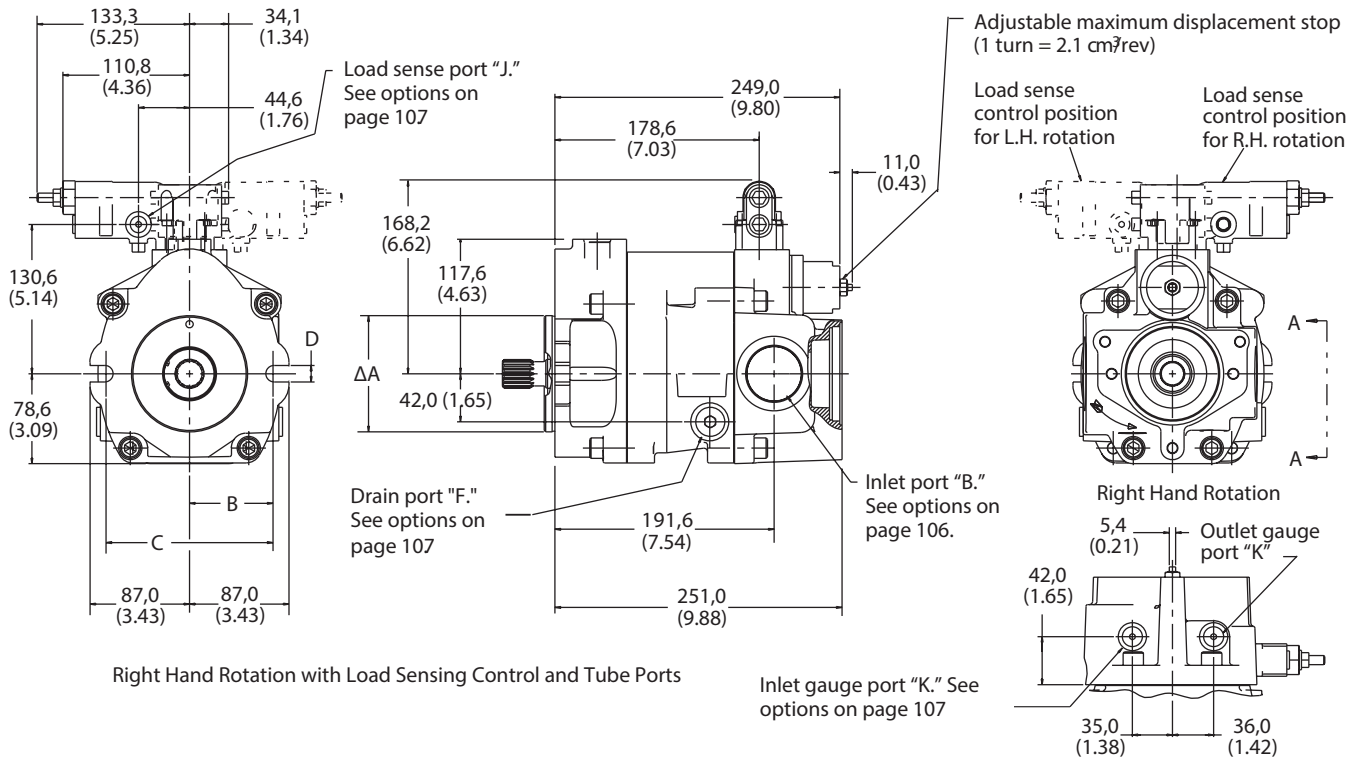
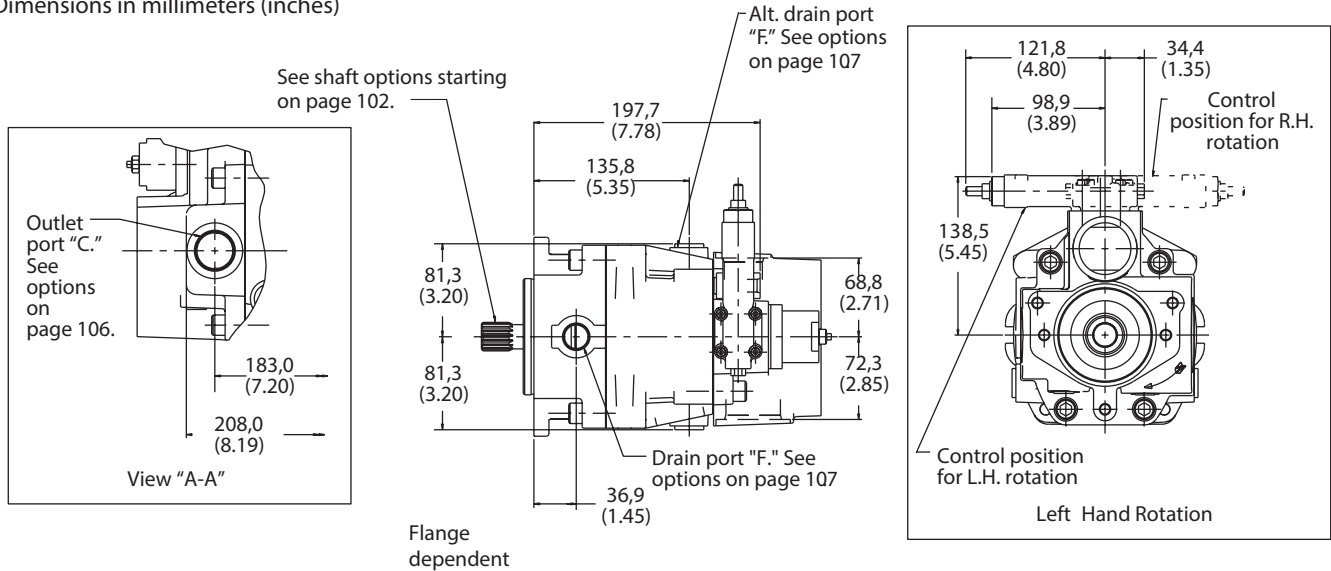

# Thru-drive Models

PVM045/050

Dimensions in millimeters (inches)

"A" Pad

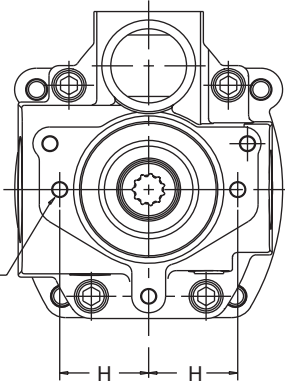
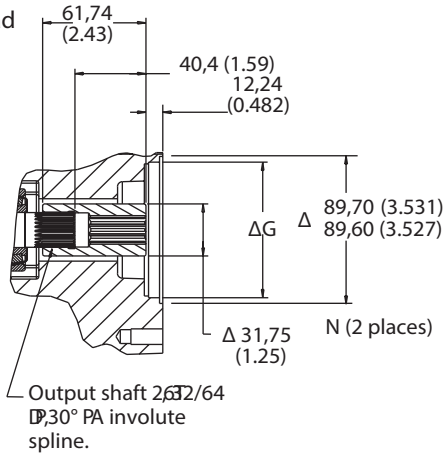

"B" Pad

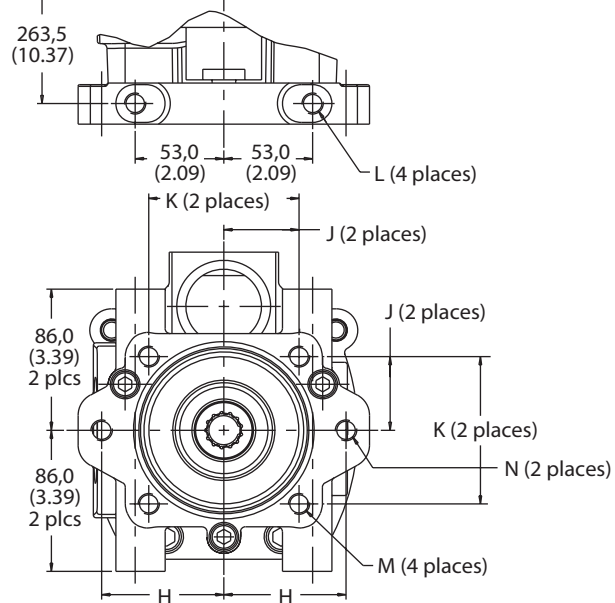
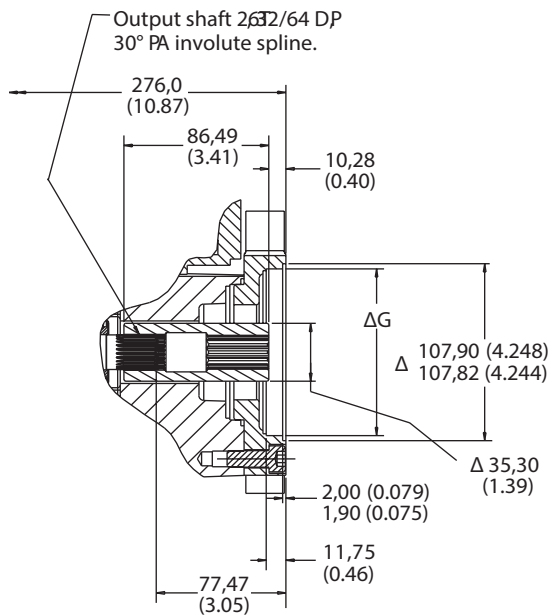

Model Code Position 25

	Description
A	For SAE "A" pad with a 9T, 16/32 DP, 30° pressure angle, involute spline
B	For SAE "A" pad with a 11T, 16/32 DP, 30° pressure angle, involute spline
C	For SAE "B" pad with a 13T, 16/32 DP, 30° pressure angle, involute spline
D	For SAE "B" pad with a 15T, 16/32 DP, 30° pressure angle, involute spline
G	For ISO 80-A2HW pad with a 9T SAE spline
H	For ISO 80-A2HW pad with a 11T SAE spline
J	For ISO 100-A2/B4HW pad with a 13T SAE spline

Model Code Position 25	ØG	H	J	K	L	M	N
A,B	82,58 (3.251) 82,52 (3.249)	53,2 (2.09)	-	-	-	-	.375-16 UNC-2B thd. 0.60 deep min.
G,H	80,046 (3.15) 80,002 (3.149)	54,5 (2.15)	-	-	-	-	M10 thd. x 1,50 15,0 deep min.
C,D	101,65 101,60 (4.00)	73,0 (2.87)	44,9 (1.77)	89,8 (3.54)	.500-13 UNC-2B thd. 24,9 deep min. M12 x 1,50 thd. 24,9 deep min.	.500-13 UNC-2B thd. thru M10 x 1,50 thd. thru	.500-13 UNC-2B thd. thru M12 x 1,50 thd. thru
J,K	100,0 (3.937) 99,946 (3.935)	70,0 (2.76)	44,2 (1.74)	88,38 (3.48)	M12 thd. x 1,50 thd. 24,9 deep min.	M10 x 1,50 thd. thru	M12 x 1,50 thd. thru

# Flange Designations

PVM045/050

Pilot Flange Designation	ØA	B	C	D	E
SAE J744-101-2	101,60/101,55 (4.000/3.998)	9,70/9,19 (.382/.362)	146,0 (5.750)	73,0 (2.875)	14,55/14,17 (.572/.557)
ISO 3019/2-100A2HW	100,00/99,95 (3.937/3.935)	9,50/9,00 (.374/.354)	140,0 (5.512)	70,0 (2.756)	14,27/14,00 (.562/.551)

Pilot Flange Designation	ØA	B	C	D
SAE 2-bolt mount	101,60/101,55 (4.000/3.998)	73,0 (2.87)	146,0 (5.750)	14,55/14,17 (.572/.557)
ISO 100 2-bolt mount	100,00/99,95 (3.937/3.935)	70,0 (2.76)	140,0 (5.512)	14,27/14,00 (.562/.551)

# End-ported Models

PVM057/063

Dimensions in millimeters (inches)  
 See mounting flange options on page 101.  
 See shaft options starting on page 102.

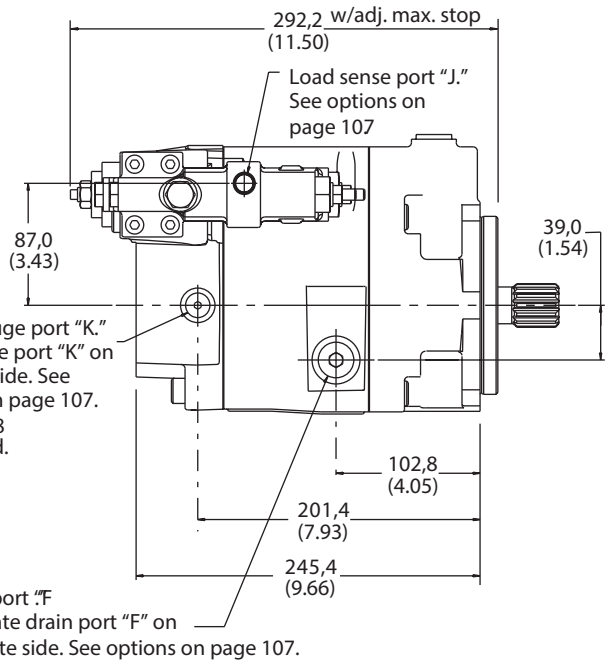
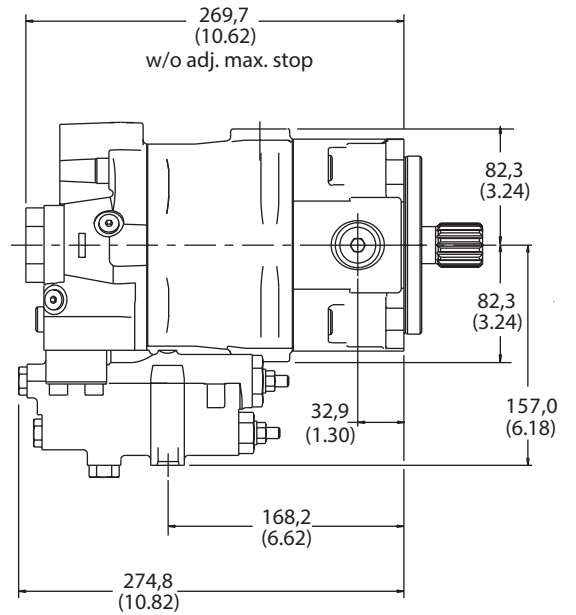
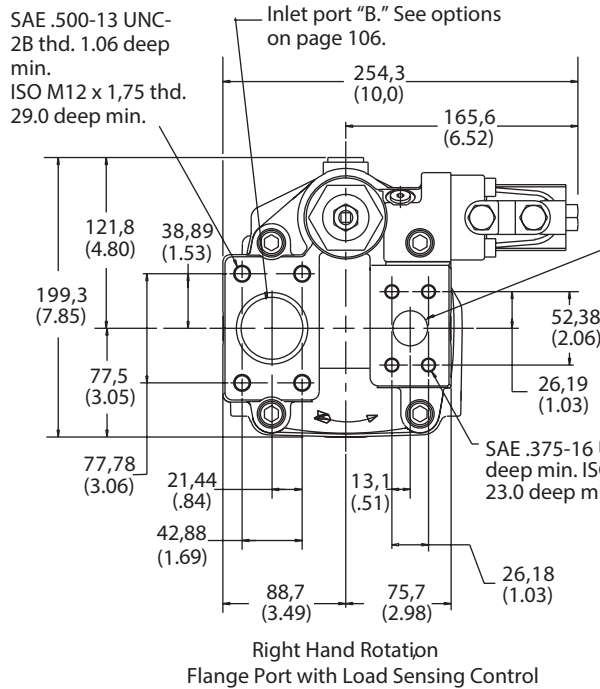
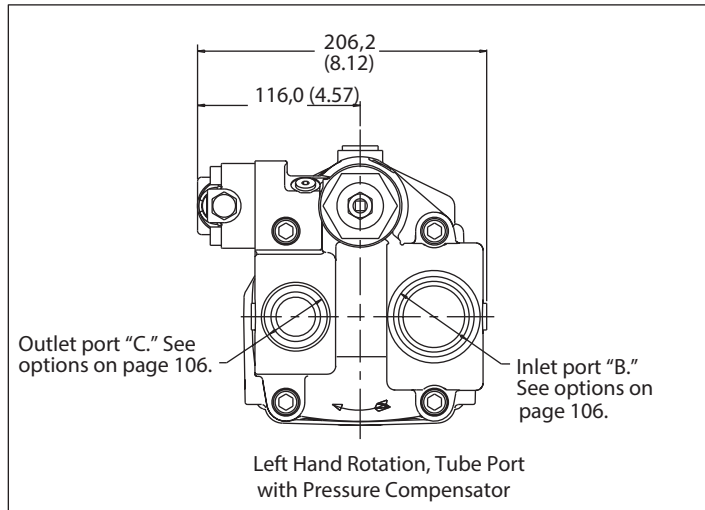

# Side-ported Models

PVM057/063

Dimensions in millimeters (inches)

See mounting flange options on page 101.

See shaft options starting on page 102.

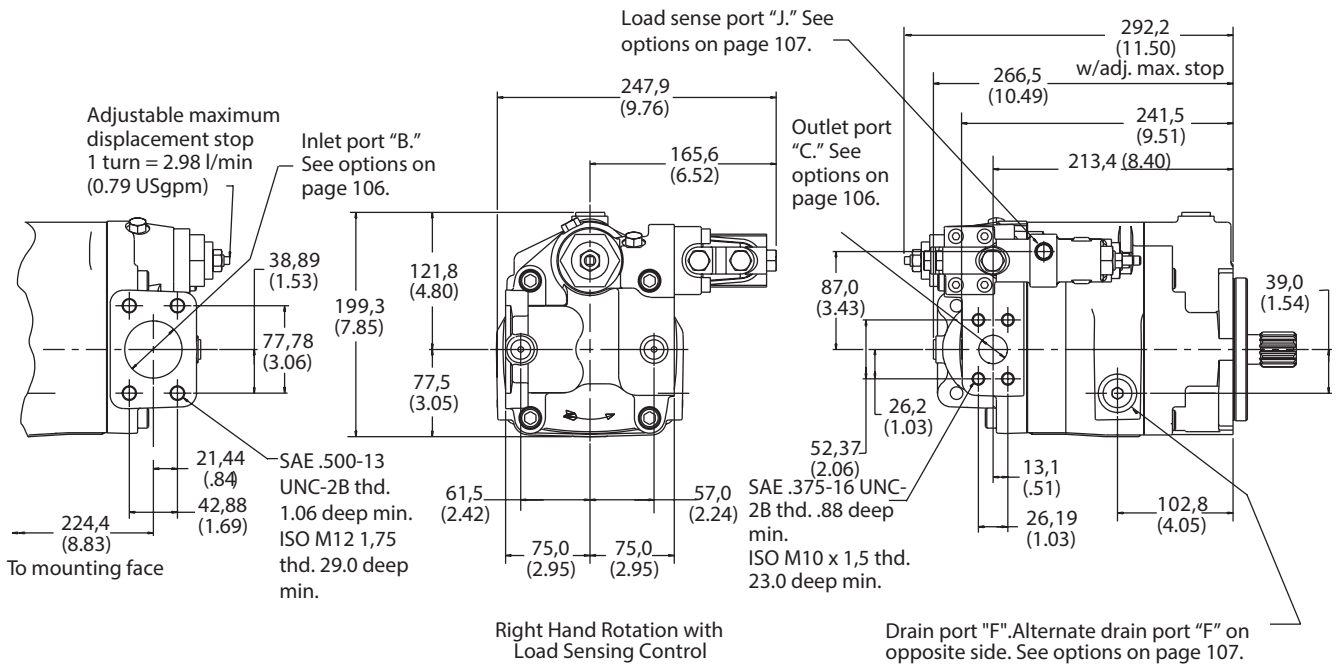
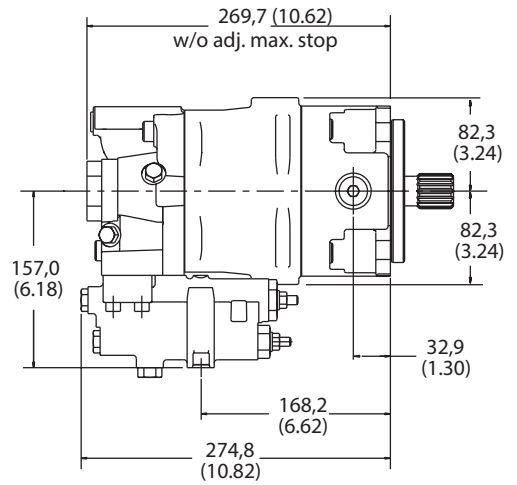
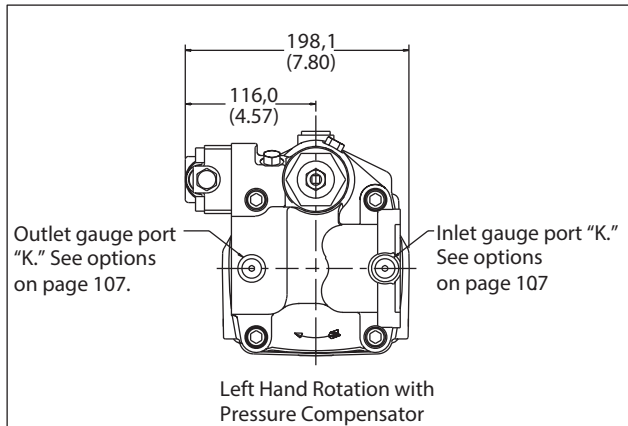

# Thru-drive Models

PVM057/063

Dimensions in millimeters (inches)  
 See pilot flange options on page 101.  
 See shaft options starting on page 102.

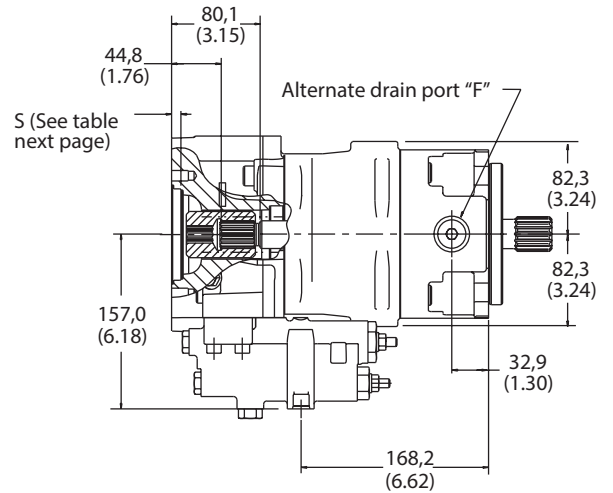
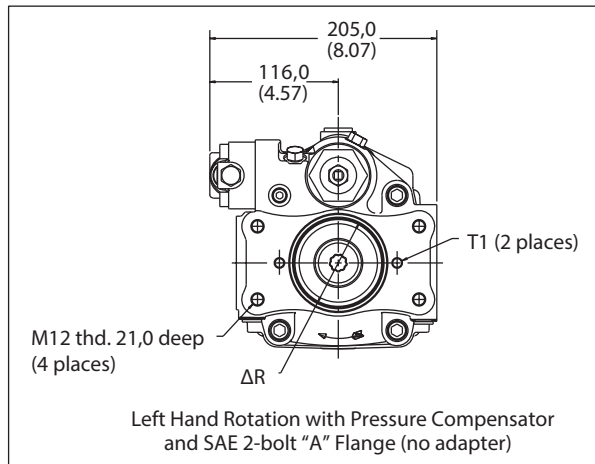

SAE .500-13 UNC-2B thd.  
 1.06 deep min.  
 ISO M12 x 1,75 thd.  
 29.0 deep min.

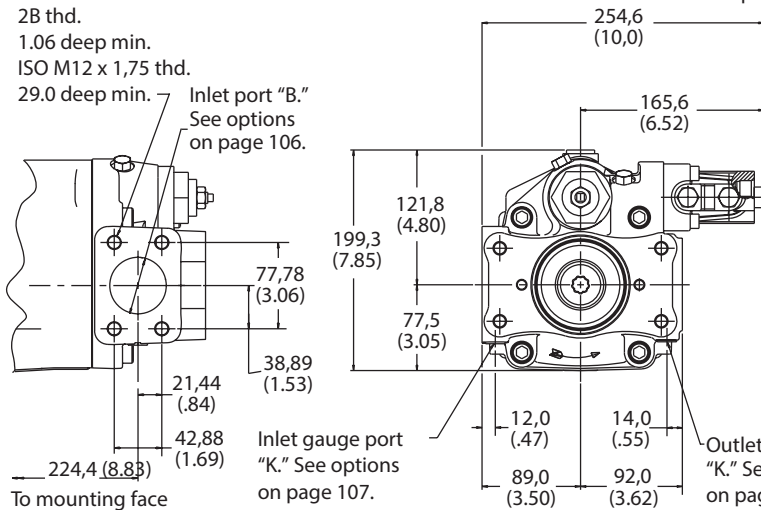

Load sense port "J," See options on page 107.

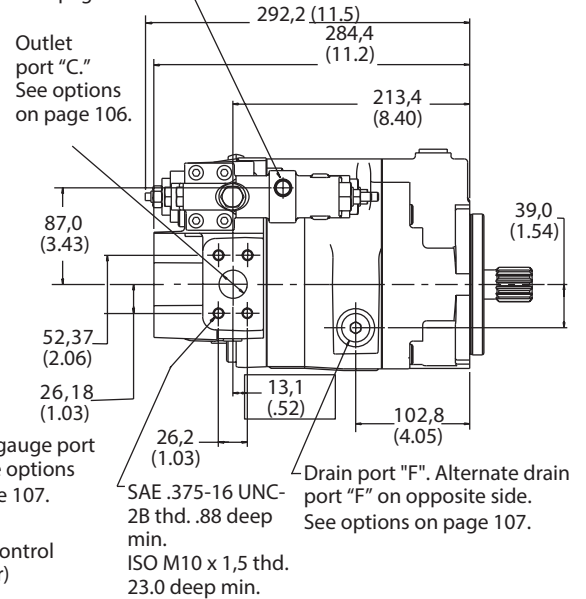

Right Hand Rotation with Load Sensing Control and SAE 2-bolt "A" Flange (no adapter)

# Thru-drive Models

PVM057/063

Dimensions in millimeters (inches)

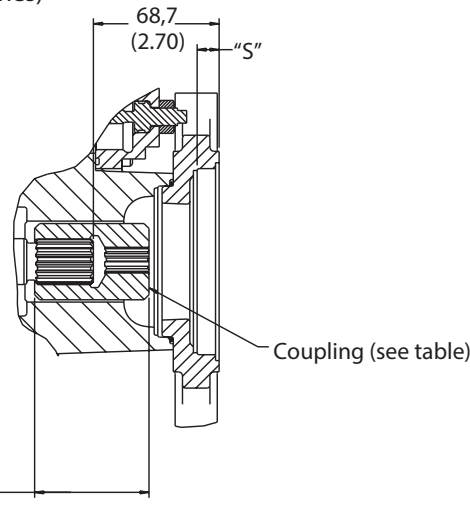

Coupling	Length	Code
SAE "A," 9T	62,5 (2.46)	A,G
SAE "B," 13T	93,0 (3.66)	C,J
SAE "B-B," 15T	93,0 (3.66)	D,K
SAE "C," 14T	93,0 (3.66)	E,L

Model Code Position 25

	Description
A	SAE "A," 9T, 16/32 DP, 30° pressure angle, involute spline
C	SAE "B," 13T, 16/32 DP, 30° pressure angle, involute spline
D	SAE "B-B," 15T, 16/32 DP, 30° pressure angle, involute spline
E	SAE "C," 14T, 12/24 DP, 30° pressure angle, involute spline
G	For ISO 80-A2HW pad with a 9T SAE spline
J	For ISO 100-A2/B4HW pad with a 13T SAE spline
K	For ISO 100-A2/B4HW pad with a 15T SAE spline
L	For ISO 125-A2/B4HW pad with a 14T SAE spline

## "B" Adapter Flange

To mounting face

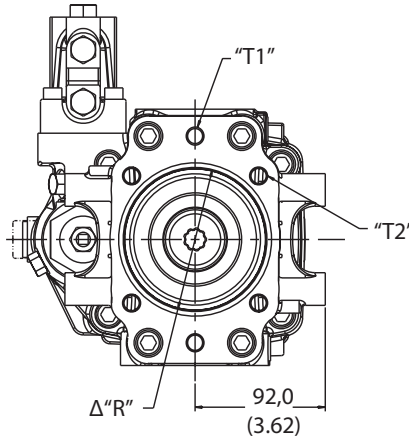
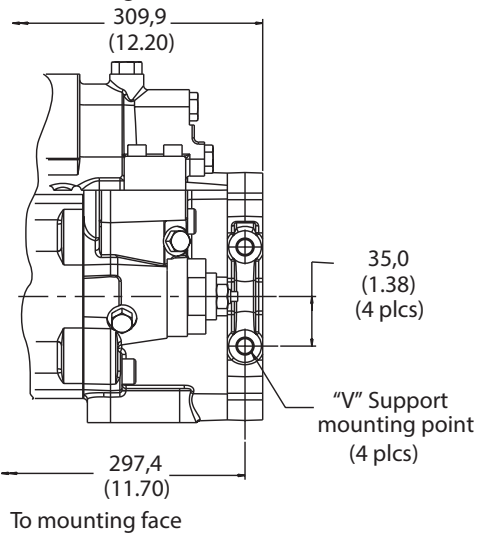

Right hand rotation with Load Sensing Control and

Model Code	Position 25		Pilot Dia. "R"	Pilot Depth "S"	Support Mounting Points		
	Flange	Bolt			2-bolt "T1"	4-bolt "T2"	"V"
A,B	SAE "A" 2-bolt	SAE	Ø82,65 (3.25±.001)	8,6/8,1 (.32/.34)	.375-16 UNC-2B thd.	N/A	N/A
G,H	ISO 80	ISO	Ø80,05 (3.15)	9,0/8,0 (.35/.31)	M10 thd.	N/A	N/A
C,D	SAE "B" 2-/4-bolt	SAE	Ø101,65 (4.002±.001)	12,5/11,5 (.49/.45)	.50-13 UNC-2B thd.	.50-13 UNC-2B thd.	.50-13 UNC-2B thd. .98" deep
J,K	ISO 100	ISO	Ø100,05 (3.94)	12,5/11,5 (.49/.45)	M12 thd.	M12 thd.	M12 thd. x 25,0 deep



# Thru-drive Models

PVM057/063

Dimensions in millimeters (inches)

## "C" Adapter Flange

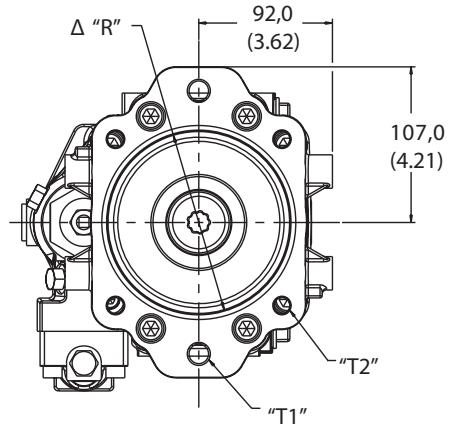
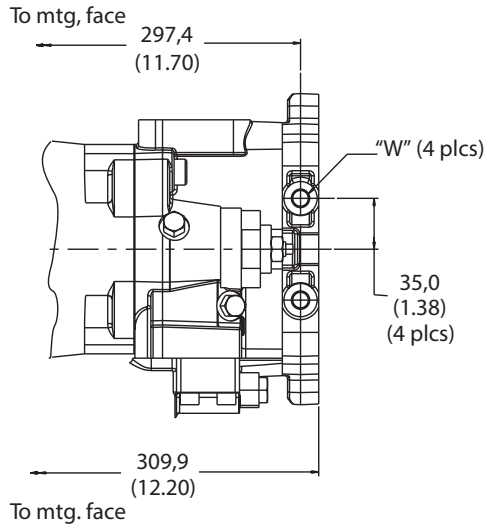

Left hand rotation with Pressure Compensator and SAE 2-/4-bolt "C" Adapter Flange

Model Code	Position 25	Flange	Bolt	Pilot Dia.		Pilot Depth		2-bolt	4-bolt	Support Mounting Points
				"R"	"S"	"T1"	"T2"	"V"		
E,F	SAE "C" 2-/4-bolt	SAE	Ø127,05 (5.002±.001)	15,5/14,5 (.61/.57)	.625-11 UNC-2B thd.	.50-13 UNC-2B thd.	.50-13 UNC-2B thd.	.98" deep		
L,M	ISO 125	ISO	Ø125,05 (4.92)	15,5/14,5 (.61/.57)	M16 thd.	M12 thd.	M12 thd. x 25,0 deep			

# Side-ported Models

PVM074/081

\*Right Hand Only

Dimensions in millimeters (inches)

See pilot flange options on page 101.  
See shaft options starting on page 102.

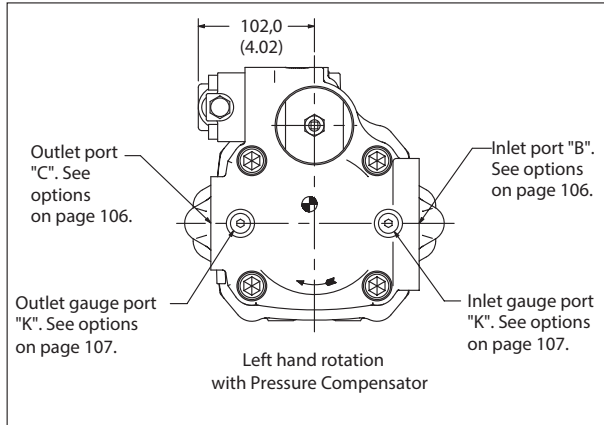

Lifting point .375-16 UNC thd.  
10,0 (.39) deep with SAE drain  
M10 thd. 10,0 (.39) deep with ISO drain.

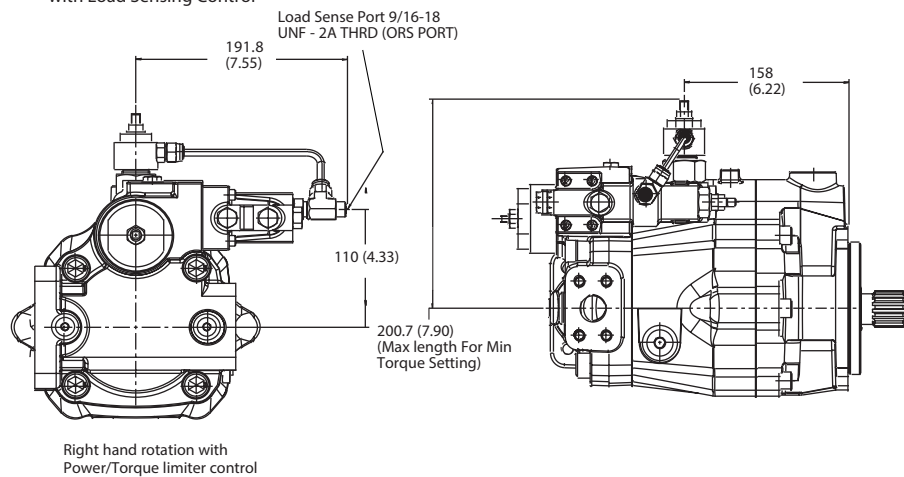
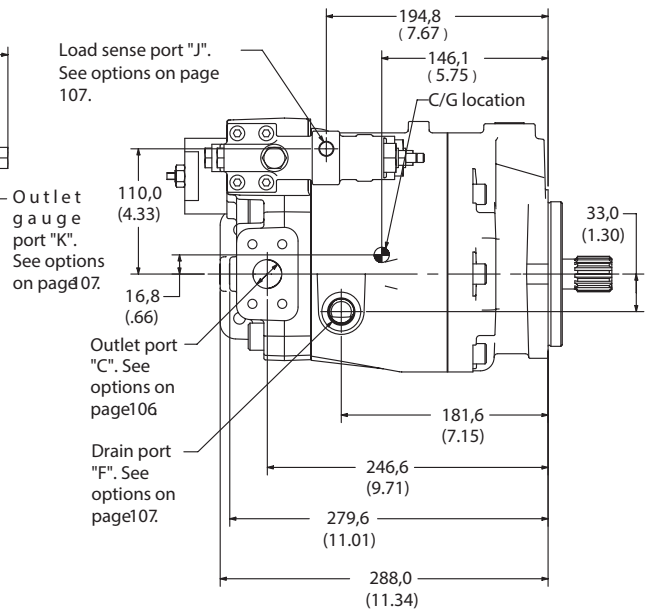
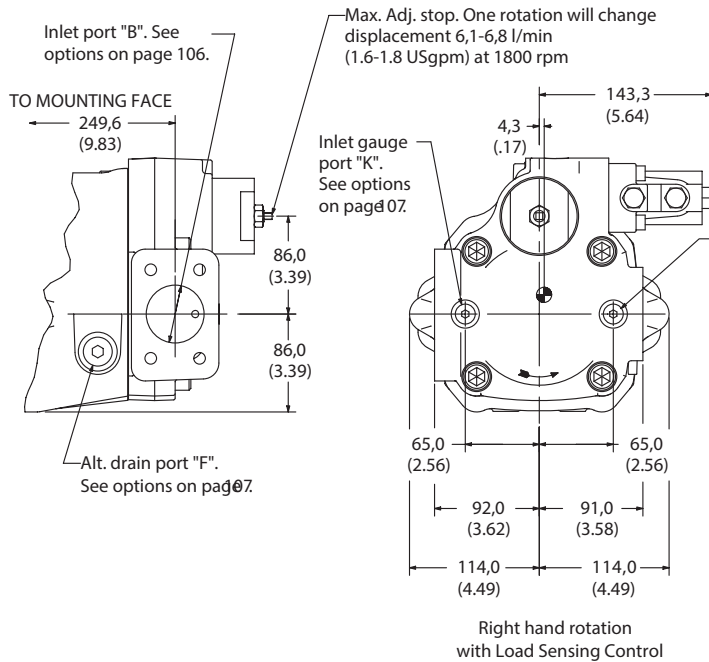
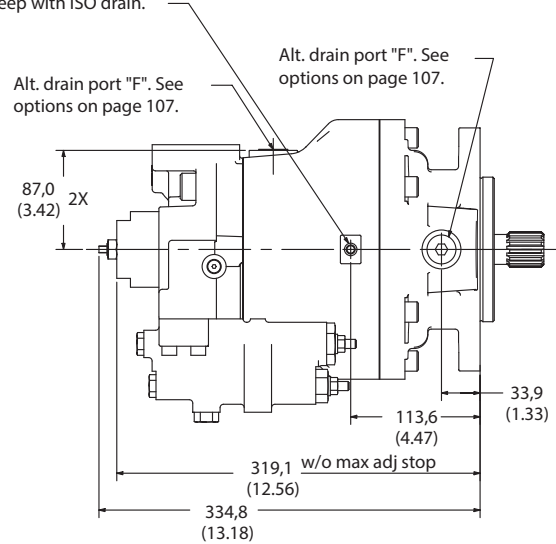

PVM074/108 is not available with left hand rotation in any port configuration.

# Thru-drive Models

PVM074/081 \*Right-hand only

Dimensions in millimeters (inches)

See pilot flange options on page 101.  
See shaft options starting on page 102.

Lifting point .375-16 UNC thd.  
10,0 (.39) deep with SAE drain  
M10 thd. 10,0 (.39) deep with ISO drain

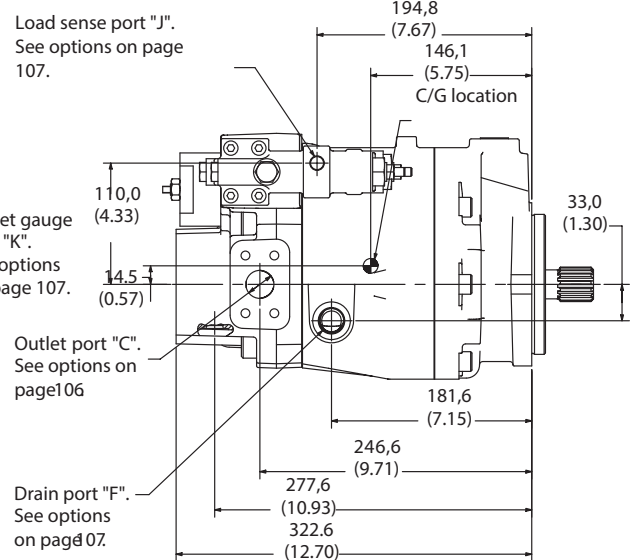
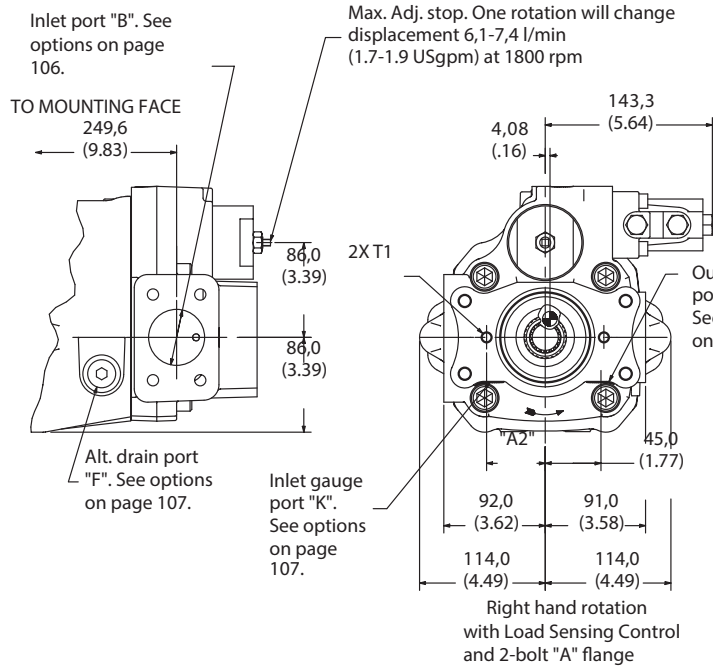
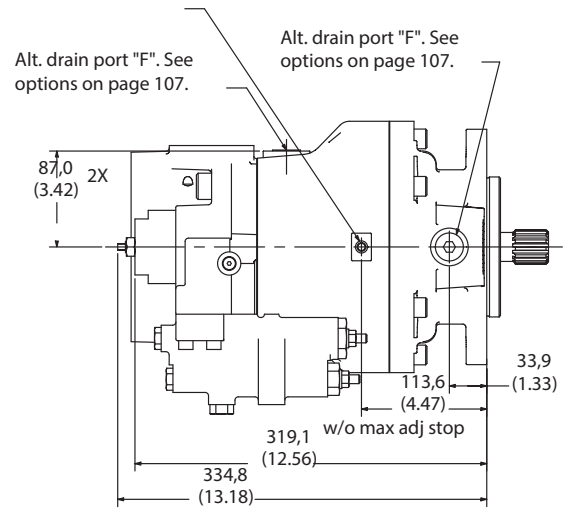
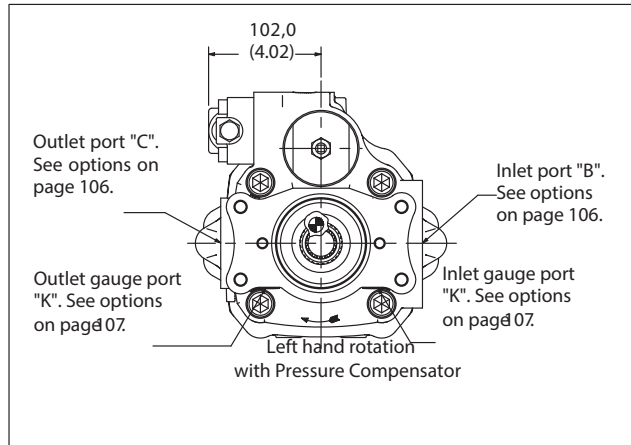

PVM074/108 is not available with left hand rotation in any port configuration.

# Thru-drive Models

PVM074/081 \*Right-hand only

Dimensions in millimeters (inches)

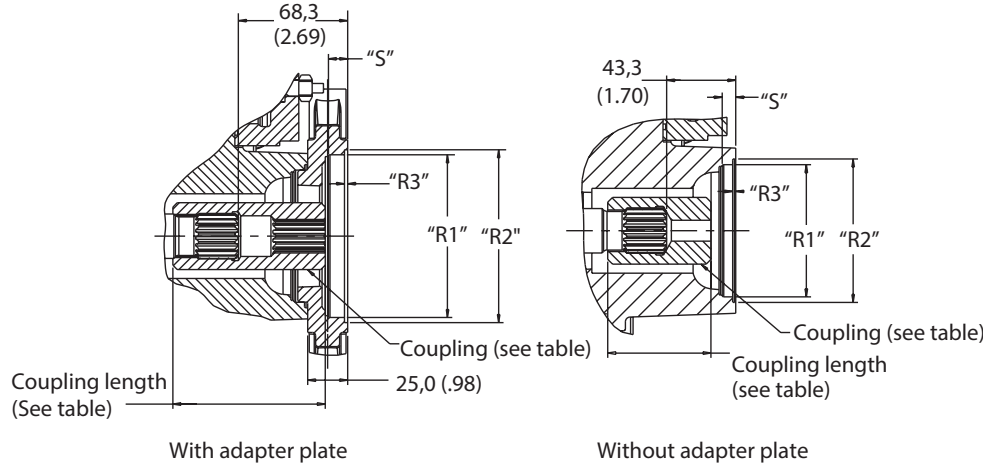

Coupling	Length	Code
SAE "A," 9T	64,5 (2.54)	A,G
SAE "A," 11T	65,3 (2.57)	B,H
SAE "B," 13T	95,3 (3.75)	C,J
SAE "B-B," 15T	95,3 (3.75)	D,K
SAE "C," 14T	95,3 (3.75)	E,L
SAE "C-C," 17T	91,8 (3.61)	F,M

Model code	Position 25	Description
A	SAE "A," 9T, 16/32 DP, 30° pressure angle, involute spline	
B	SAE "A," 11T, 16/32 DP, 30° pressure angle, involute spline	
C	SAE "B," 13T, 16/32 DP, 30° pressure angle, involute spline	
D	SAE "B-B," 15T, 16/32 DP, 30° pressure angle, involute spline	
E	SAE "C," 14T, 12/24 DP, 30° pressure angle, involute spline	
F	SAE "C-C," 17T, 12/24 DP, 30° pressure angle, involute spline	
G	For ISO 80-A2HW pad with a 9T SAE spline	
H	For ISO 80-A2HW pad with a 11 T SAE spline	
J	For ISO 100-A2/B4HW pad with a 13T SAE spline	
K	For ISO 100-A2/B4HW pad with a 15T SAE spline	
L	For ISO 125-A2/B4HW pad with a 14T SAE spline	
M	For ISO 125-A2/B4HW pad with a 17T SAE spline	

## "B" Adapter Flange

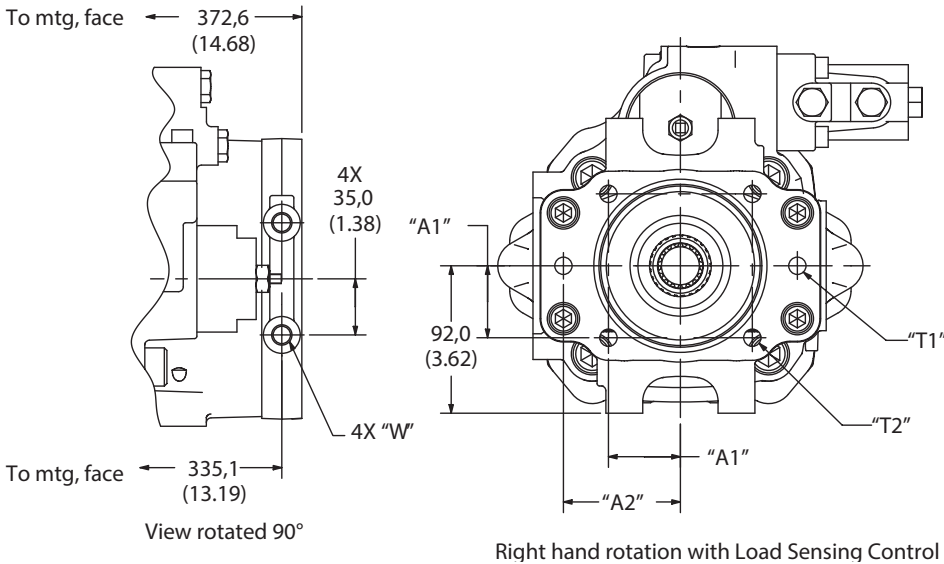

Right hand rotation with Load Sensing Control

Model Code	Position 25 Flange	Bolt	Pilot	O-ring	O-ring	Pilot	2-bolt	4-bolt	Support	4-bolt	2-bolt
			Flange	Flange	Flange	Flange	Flange	Flange	Flange	Flange	Flange
			"R1"	"R2"	"R3"	"S"	"T1"	"T2"	"W"	"A1"	"A2"
A,B	SAE "A"	SAE	Ø82,6 (3.25)	Ø89,65 (3.53)	2,00 (.08) 1,90 (.07)	9,0/8,0 (.35/.31)	375-16 UNC-2B thd.	N/A	N/A	N/A	53,2 G,H
	ISO 80	ISO	Ø80,05 (3.15)	Ø89,75 (3.53)	2,70 (.11) 2,60 (.10)	9,0/8,0 (.35/.31)	M10 thd.	N/A	N/A	N/A	54,5 (2.15)
C,D J,K	SAE "B"	SAE	Ø101,65 (4.00)	Ø108,05 (4.25)	2,00 (.08) 1,90 (.07)	12,5/11,5 (.49/.45)	.50-13 UNC-2B thd.	.50-13 UNC-2B thd.	.50-13 UNC-2B thd. .98" deep(1.77)	44,9 (2.87)	73,0
	ISO 100	ISO	Ø100,05 (3.94)	Ø108,75 (4.28)	2,70 (.11) 2,60 (.10)	12,5/11,5 (.49/.45)	M12 thd.	M10 thd.	M12 thd. 25,0 deep	44,19 (1.74)	70,0 (2.76)

# Thru-drive Models

PVM074/081 \*Right-hand only

Dimensions in millimeters (inches)

"C" Adapter Flange

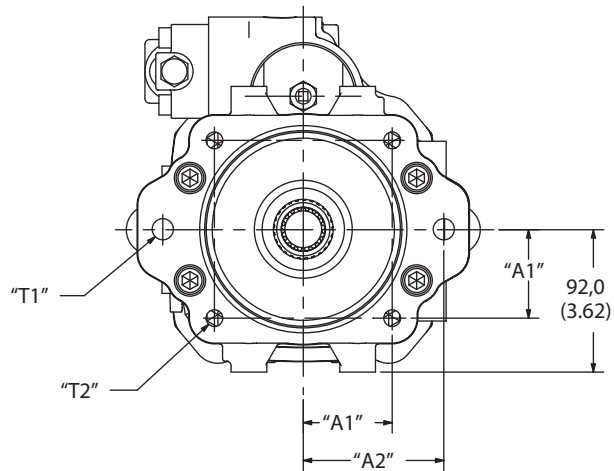
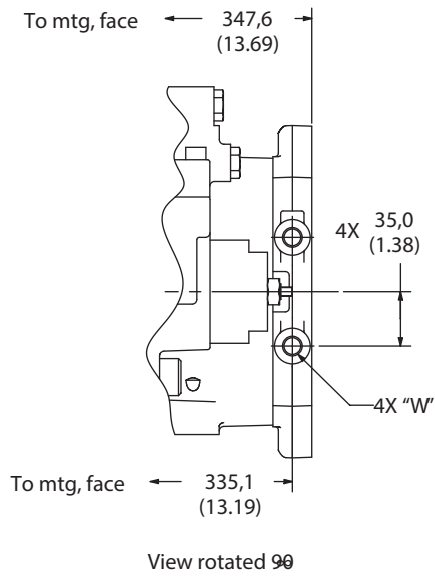

Left hand rotation with Pressure Compensator and ISO or SAE 2-/4-bolt "C" Adapter Flange

Model Code	Position 25	Pilot	O-ring		Pilot	Support Mounting Points		Support Mounting Points			
			Dia.	Dia.		Depth	Depth	2-bolt	4-bolt	"W"	"A1"
	Flange	Bolt	"R1"	"R2"	"R3"	"S"	"T1"	"T2"	"W"	"A1"	"A2"
E,F	SAE "C"	SAE	Ø127,05	Ø133,45	2,00 (.08)	15,5/14,5	.625-11 UNC-2B thd.	.50-13 UNC-2B thd.	.50-13 UNC-2B thd. .98" deep	57,25 (2.25)	90,5 (3.56)
L,M	ISO 125	ISO	Ø125,05 (4.92)	Ø133,75 (3.26)	2,70 (.11) 2,60 (.10)	15,5/14,5 (.61/.57)	M16 thd.	M12 thd.	M12 thd. 25,0 deep	56,57 (2.23)	90,0 (3.54)

# Side-ported Models

PVM098/106

Dimensions in millimeters (inches)

See pilot flange options on page 101.  
See shaft options starting on page 102.

Alt. drain port "F". See options on page 107.

Lifting point .375-16 UNC thd.10,0 (.39) deep with  
SAE drain M10 thd. 10,0 (.39) deep with ISO drain

Alt. drain port "F". See  
options on page 107.

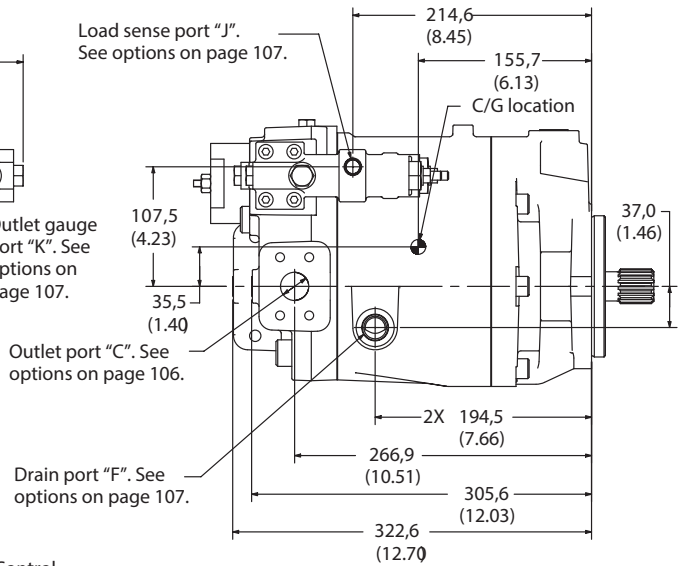
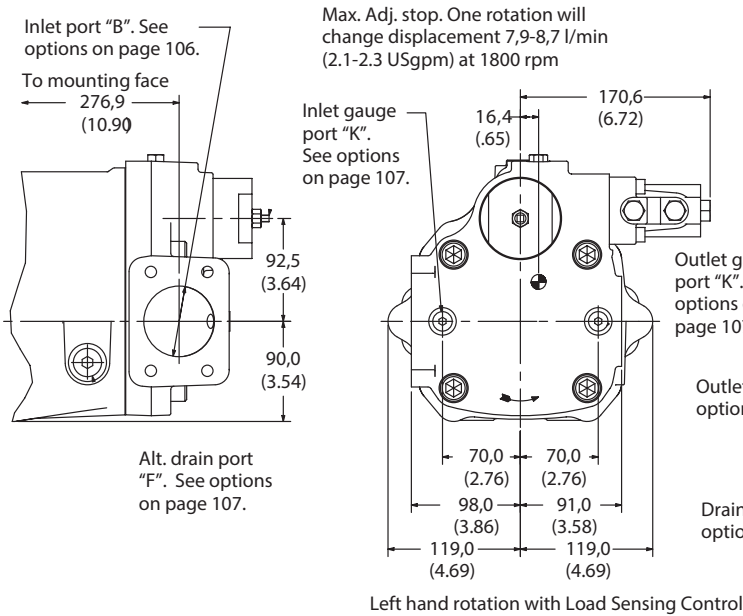
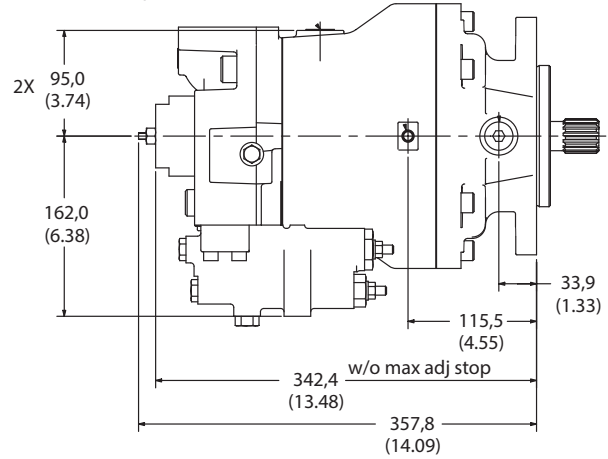
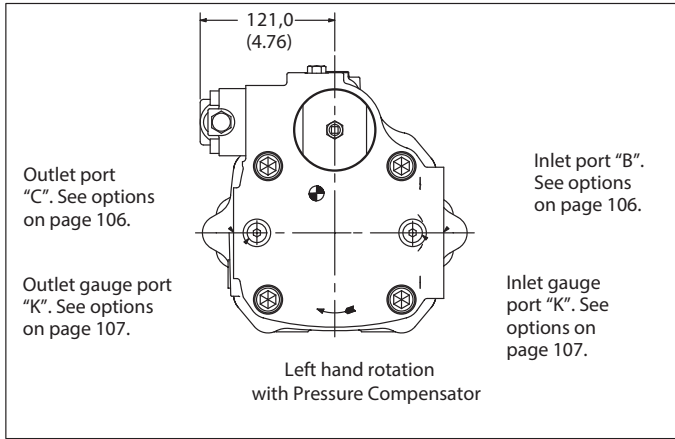

PVM098/106 is not available in left hand rotation with rear ports.

# Thru-drive Models

PVM098/106

Dimensions in millimeters (inches)

See pilot flange options on page 101.  
See shaft options starting on page 102.

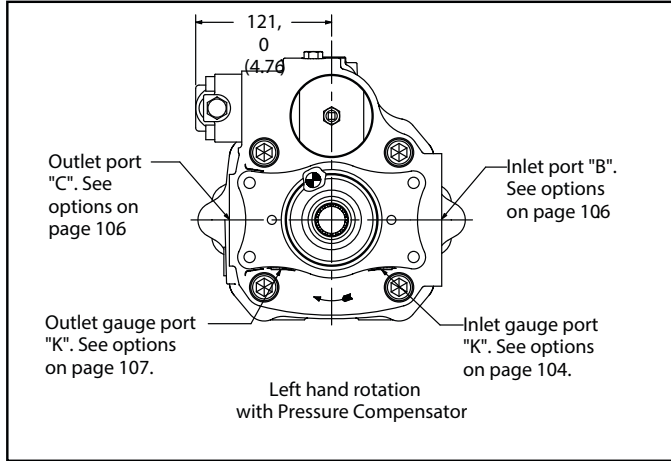

Alt. drain port "F". See options on page 107.  
Lifting point .375-16 UNC thd. 10,0 (.39) deep with SAE drain M10 thd. 10,0 (.39) deep with ISO drain

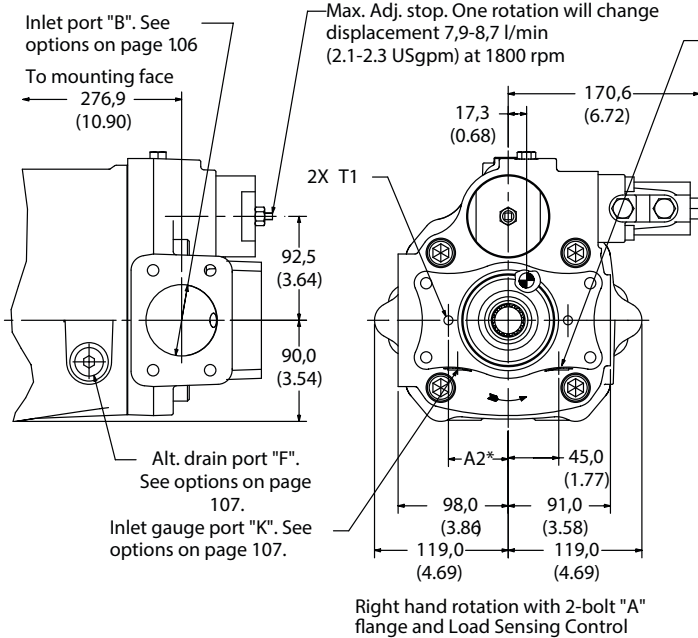
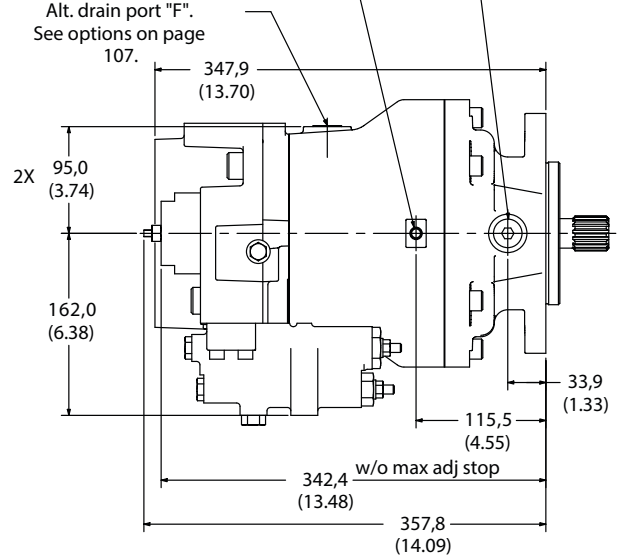

Outlet gauge port "K". See options on page 107.

Load sense port "J". See options on page 107.

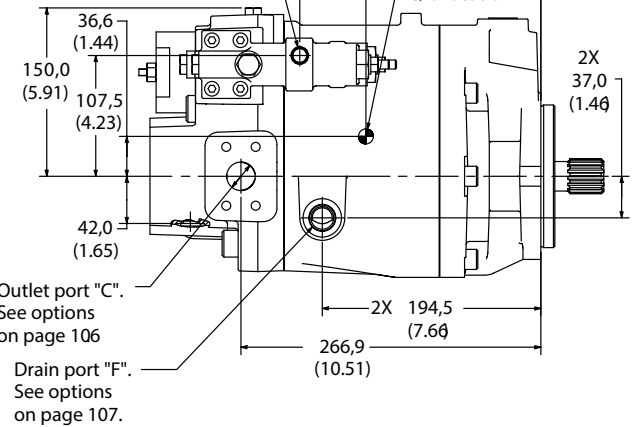

PVM098/106 is not available in left hand rotation with rear ports.

# Thru-drive Models

PVM098/106

Dimensions in millimeters (inches)

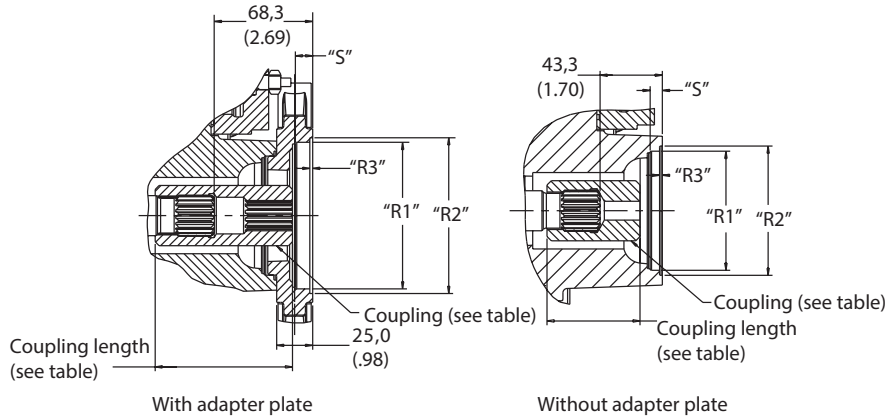

Coupling	Length	Code
SAE "A," 9T	64,5 (2.54)	A,G
SAE "A," 11T	65,3 (2.57)	B,H
SAE "B," 13T	95,3 (3.75)	C,J
SAE "B-B," 15T	95,3 (3.75)	D,K
SAE "C," 14T	95,3 (3.75)	E,L
SAE "C-C," 17T	91,8 (3.61)	F,M

Model Code Position 25 Description

A	SAE "A," 9T, 16/32 DP, 30° pressure angle, involute spline
B	SAE "A," 11T, 16/32 DP, 30° pressure angle, involute spline
C	SAE "B," 13T, 16/32 DP, 30° pressure angle, involute spline
D	SAE "B-B," 15T, 16/32 DP, 30° pressure angle, involute spline
E	SAE "C," 14T, 12/24 DP, 30° pressure angle, involute spline
F	SAE "C-C," 17T, 12/24 DP, 30° pressure angle, involute spline
G	For ISO 80-A2HW pad with a 9T SAE spline
H	For ISO 80-A2HW pad with a 11 T SAE spline
J	For ISO 100-A2/B4HW pad with a 13T SAE spline
K	For ISO 100-A2/B4HW pad with a 15T SAE spline
L	For ISO 125-A2/B4HW pad with a 14T SAE spline
M	For ISO 125-A2/B4HW pad with a 17T SAE spline

## "B" Adapter Flange

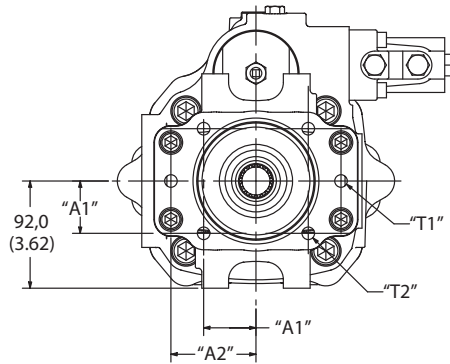
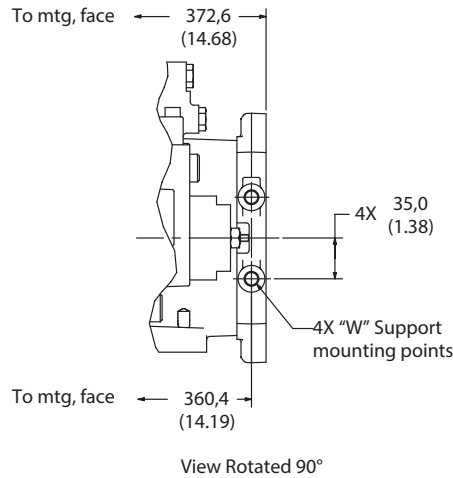

Right hand rotation with Load Sensing Control

Model Code	Position 25 Flange	Bolt	Pilot Dia.	O-ring Dia.	O-ring Depth	Pilot Depth	2-bolt	4-bolt	Support Mounting Points	4-bolt	2-bolt
			"R1"	"R2"	"R3"	"S"	"T1"	"T2"	"W"	"A1"	"A2"
A,B	SAE "A"	SAE	Ø82,6 (3.25)	Ø89,65 (3.53)	2,00 (.08)	9,0/8,0 (.35/.31)	375-16 UNC-2B thd. 0.59 deep	N/A	N/A	N/A	53,2 (2.15)
G,H	2-bolt	ISO 80	Ø80,05 (3.15)	Ø89,75 (3.53)	2,70 (.11)	9,0/8,0 (.35/.31)	M10 thd. x 18,0 deep	N/A	N/A	N/A	54,5 (2.15)
C,D	SAE "B"	SAE	Ø101,65	Ø108,05	2,00 (.08)	12,5/11,5 (.49/.45)	.50-13 UNC-2B thd.	.50-13 UNC-2B thd.	.50-13 UNC-2B thd. .98" deep	44,9 (1.77)	73,0 (2.87)
J,K	2-1/4-bolt (4.00)	ISO 100	Ø100,05 (3.94)	Ø108,75 (4.28)	2,70 (.11)	12,5/11,5 (.49/.45)	M12 thd.	M10 thd.	M12 thd. 25,0 deep	44,19 (1.74)	70,0 (2.76)



# Thru-drive Models

PVM098/106

Dimensions in millimeters (inches)

## "C" Adapter Flange

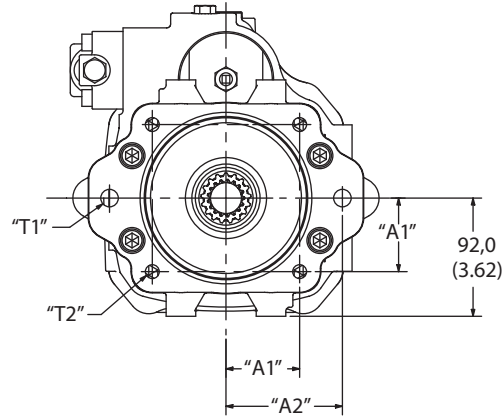
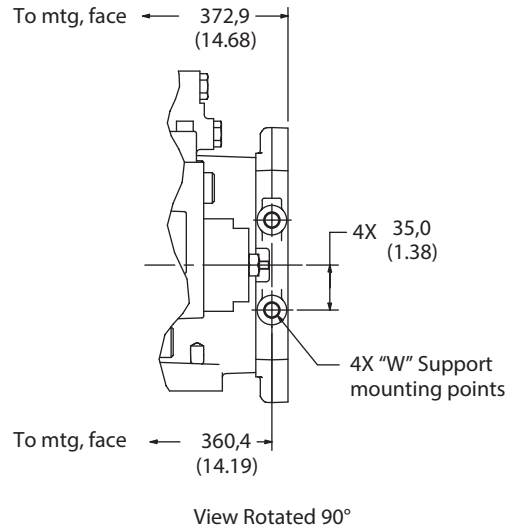

Left hand rotation with Pressure Component or and ISO or SAE 2-/4-bolt "C" adapter flange

Model Code	Position 25 Flange	Bolt	Pilot Dia.	O-ring Dia.	O-ring Depth	Pilot Depth	Support Mounting Points				
			"R1"	"R2"	"R3"	"S"	"T1"	"T2"	"W"	"A1"	"A2"
E,F L,M	SAE "C" 2-/4-bolt	SAE	Ø127,05	Ø133,45	2,00 (.08)	15,5/14,5	.625-11 UNC-2B thd.	.50-13 UNC-2B thd.	.50-13 UNC-2B thd. .98" deep	57,25 (2.25)	90,5 (3.56)
	ISO 125	ISO	Ø125,05 (4.92)	Ø133,75 (3.26)	2,70 (.11) 2,60 (.10)	15,5/14,5 (61/.57)	M16 thd.	M12 thd.	M12 thd. 25,0 deep	56,57 (2.23)	90,0 (3.54)

# End-ported Models

PVM131/141

Dimensions in millimeters (inches) See pilot flange options on page 101. See shaft options starting on page 102.

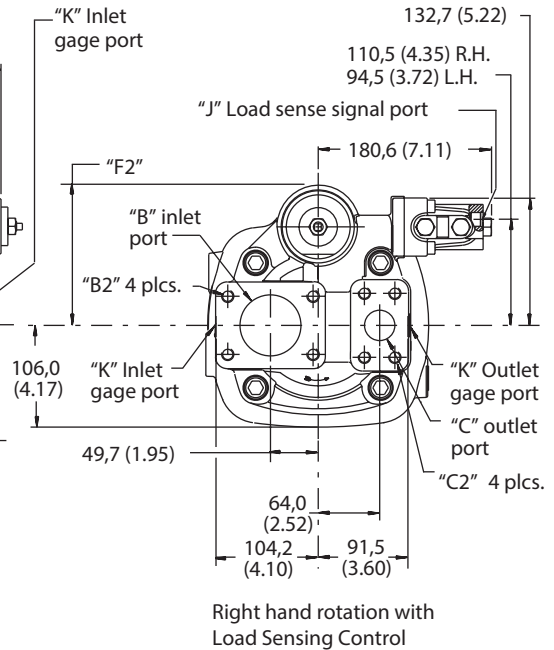
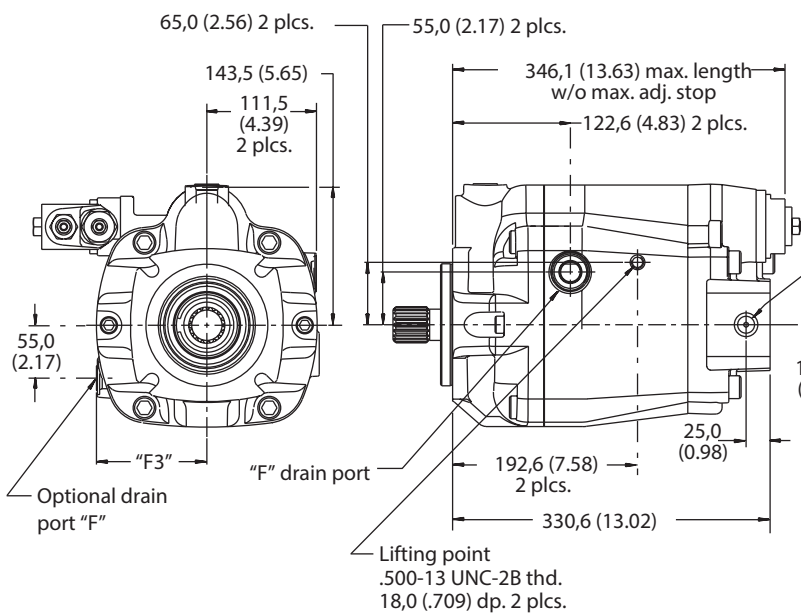
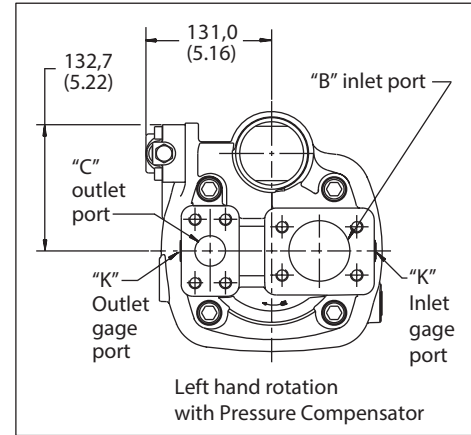
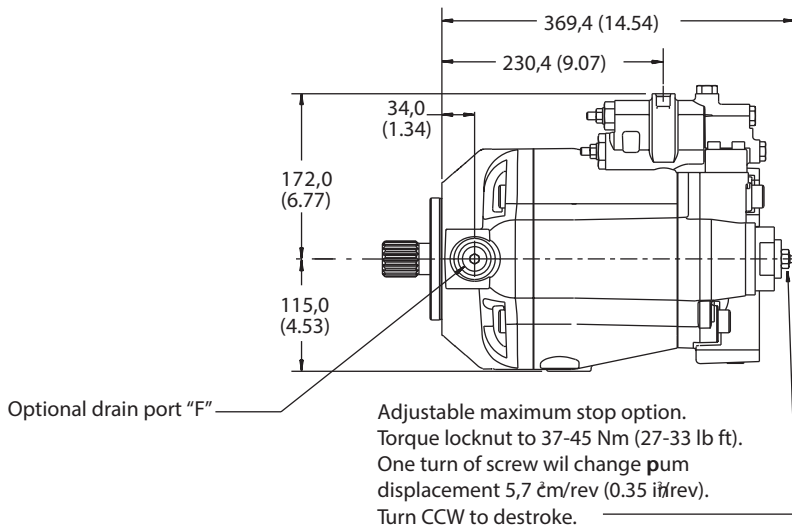

# Side-ported Models

PVM131/141

Dimensions in millimeters (inches) See pilot flange options on page 101. See shaft options starting on page 102.

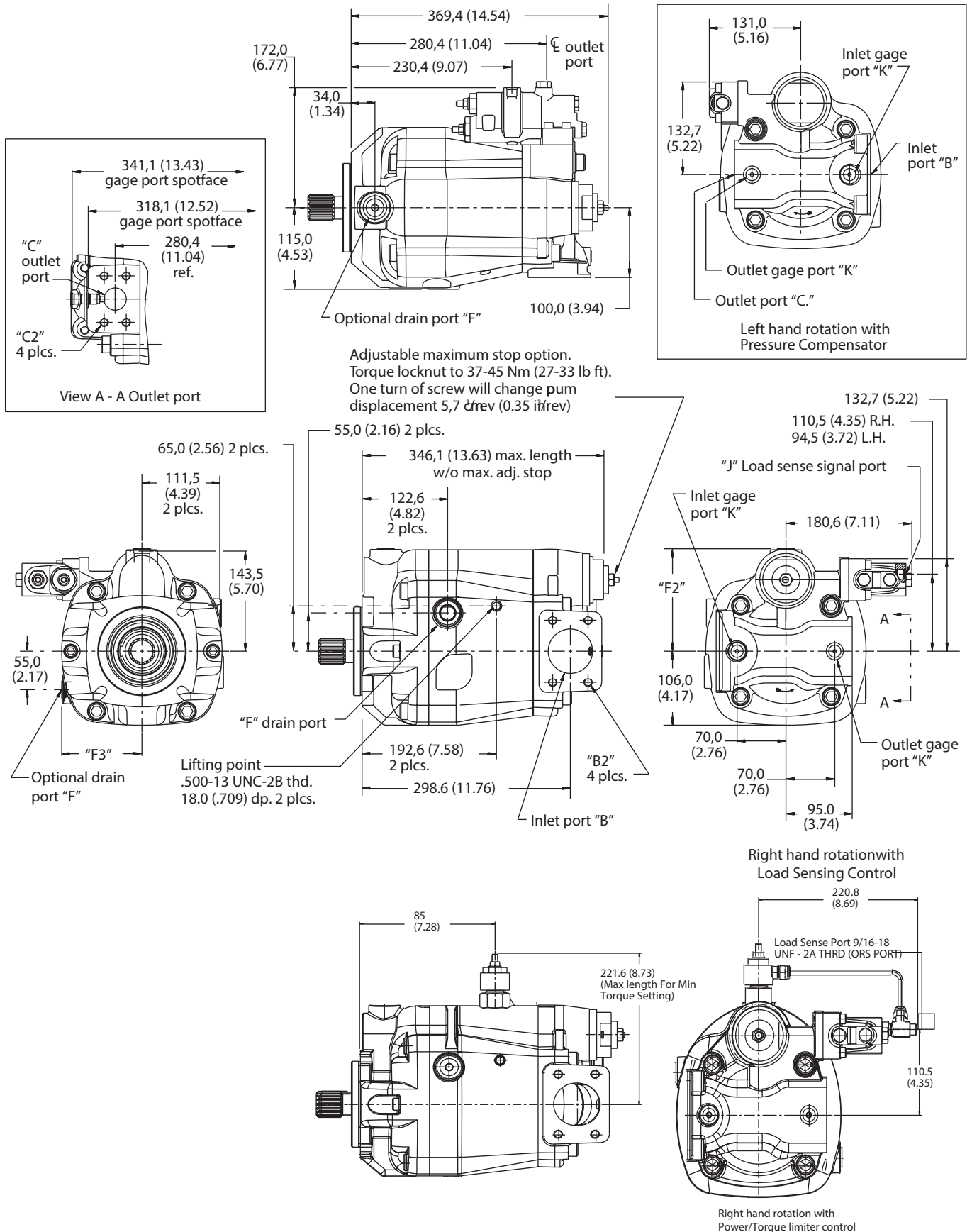

# Thru-drive Models

PVM131/141

Dimensions in millimeters (inches) See  
pilot flange options on page 101 See  
shaft options starting on page 102

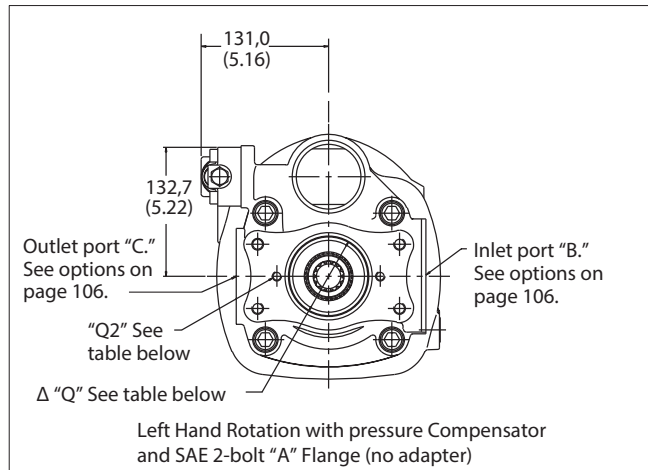
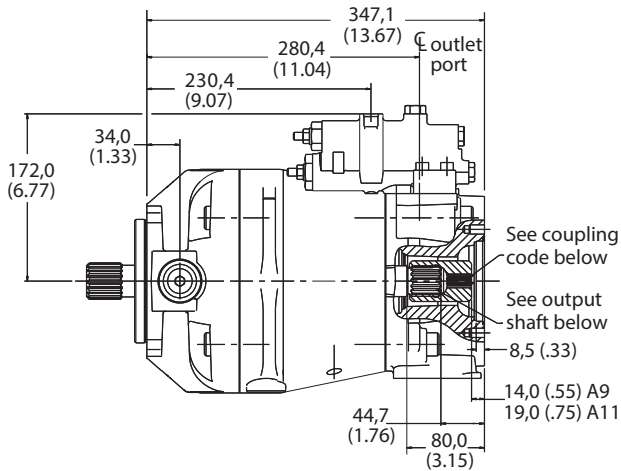

Drain port "F." See options on page 107.

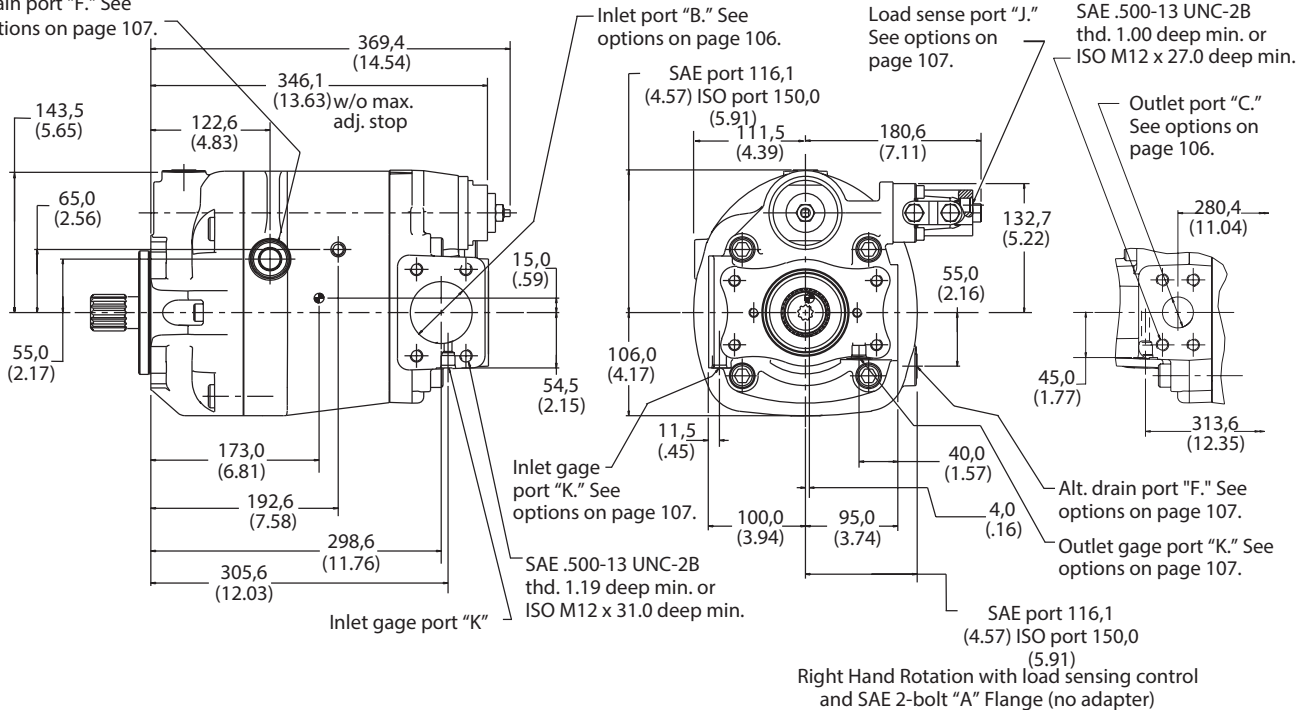

Model Code Position 25	"Q1" Thru-drive Flange	"Q2" 2-bolt Thread
A,B	SAE J744-82-2 Ø82.625/82.575 bore	.375-16 UNC-2B thd. 0.80 deep
G,H	ISO 3019/2-80A2 Ø80.075/80.25 bore	M10 thd. x 18.0 deep

# Thru-drive Models

PVM131/141

Dimensions in millimeters (inches)

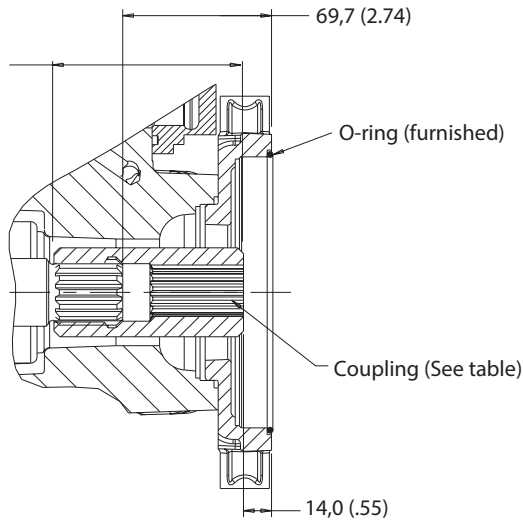

Model Code Position 25

Model Code	Description
A	For SAE "A" pad with a 9T, 16/32 DP, 30° pressure angle, involute spline
B	For SAE "A" pad with a 11T, 16/32 DP, 30° pressure angle, involute spline
Output shaft	14T 12/24 DP external involute spline
C	SAE "B," 13T, 16/32 DP, 30° pressure angle, involute spline
D	SAE "B-B," 15T, 16/32 DP, 30° pressure angle, involute spline
E	SAE "C," 14T, 12/24 DP, 30° pressure angle, involute spline
F	SAE "C-C," 17T, 12/24 DP, 30° pressure angle, involute spline
G	For ISO 80-A2HW pad with a 9T SAE spline
H	For ISO 80-A2HW pad with a 11T SAE spline
J	For ISO 100-A2/B4HW pad with a 13T SAE spline
K	For ISO 100-A2/B4HW pad with a 15T SAE spline
L	For ISO 125-A2/B4HW pad with a 14T SAE spline
M	For ISO 125-A2/B4HW pad with a 17T SAE spline

"B" Adapter Flange

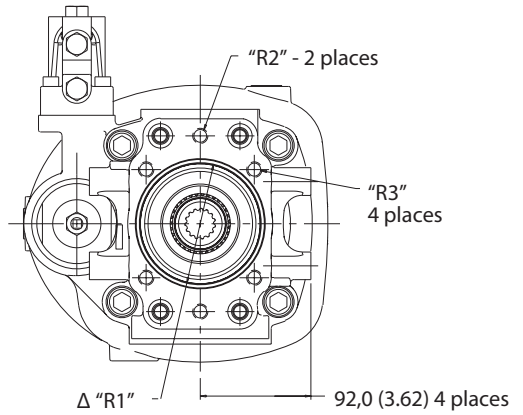
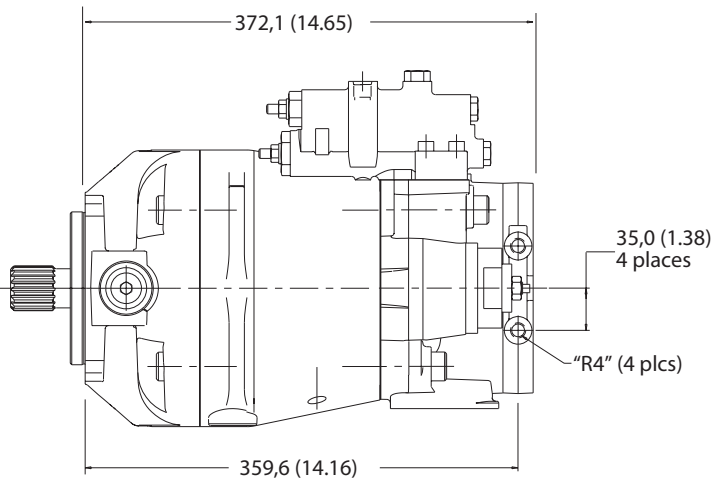

Right Hand Rotation with SAE 2-/4-Bolt  
"B" Flange and ISO 100 Adapter Flange

Model Code	"R1" Thru-drive Flange	"R2" 2-bolt Thread	"R3" 4-bolt Thread	"R4" Support Mounting Points
Position 25				
C,D	SAE J744-101-2 & -4 Ø101,675/101.625 bore 12,50/11,50 deep	.500-13 UNC-2B 0.98 deep	.500-13 UNC-2B 0.98 deep	.500-13 UNC-2B 0.98 deep
J,K	ISO 3019/2-100A2 & B2 Ø100,075/100.025 bore 12,50/11,50 deep	M12 25,0 deep	M12 25,0 deep	M12 25,0 deep

# Thru-drive Models

PVM131/141

Dimensions in millimeters (inches)

"C" Adapter Flange

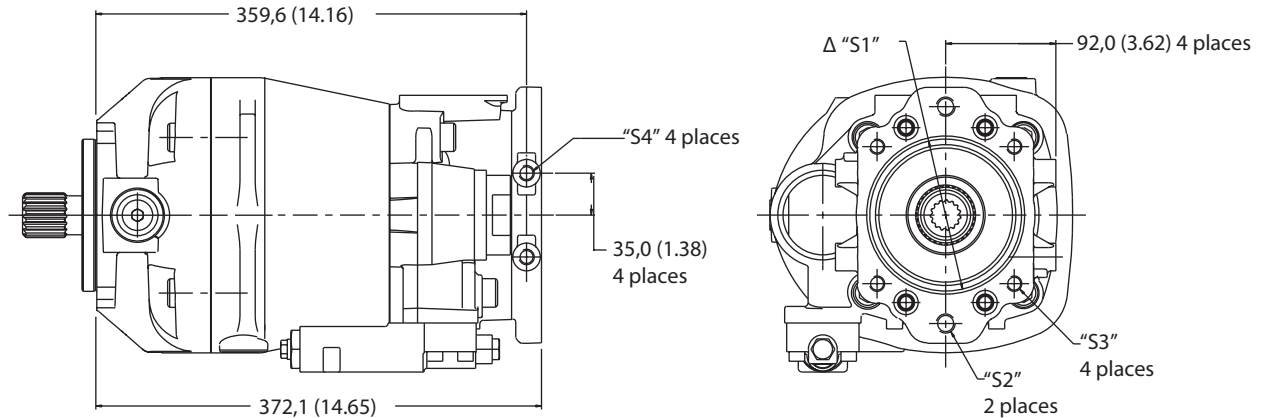

Left Hand Rotation with SAE 2-1/4-bolt "C" and ISO 125 Adapter Flange

**Model Code**

Position 25	"S1" Thru-drive Flange	"S2" 2-bolt Thread	"S3" 4-bolt Thread	"R4" Support Mounting Points
E,F	SAE J744-127-2 & -4 Ø127,075/127.025 bore 15,50/14,50 deep	.625-11 UNC-2B 0.98 deep	.500-13 UNC-2B 0.98 deep	.500-13 UNC-2B 0.98 deep
L,M	ISO 3019/2-125A2 & B4 Ø125,075/125.025 bore 15,50/14,50 deep	M16 25,0 deep	M12 25,0 deep	M12 25,0 deep

Port	"B"*	"B2"	"C"*	"C2"	"F2"	"F3"
SAE	2.50 inch dia. SAE J518 Code 61, low pressure	.500-13 UNC-2B thd. 1.19 deep minimum	1.25 inch dia. SAE J518 Code 62, high pressure	.500-13 UNC-2B thd. 1.00 deep minimum	146,8 (5.78)	114,9 (4.52)
ISO	64mm diameter. ISO 6162 Type II, 315 bar	M12 thread 31,0 deep minimum	32mm diameter. ISO 6162, 400 bar	M12 thread 27,0 deep minimum	148,5 (5.85)	116,6 (4.59)

\*4-bolt flange port. See page 101 for load sensing, drain, and gage port threads.

# Mounting Flange Options

Dimensions in millimeters (inches)

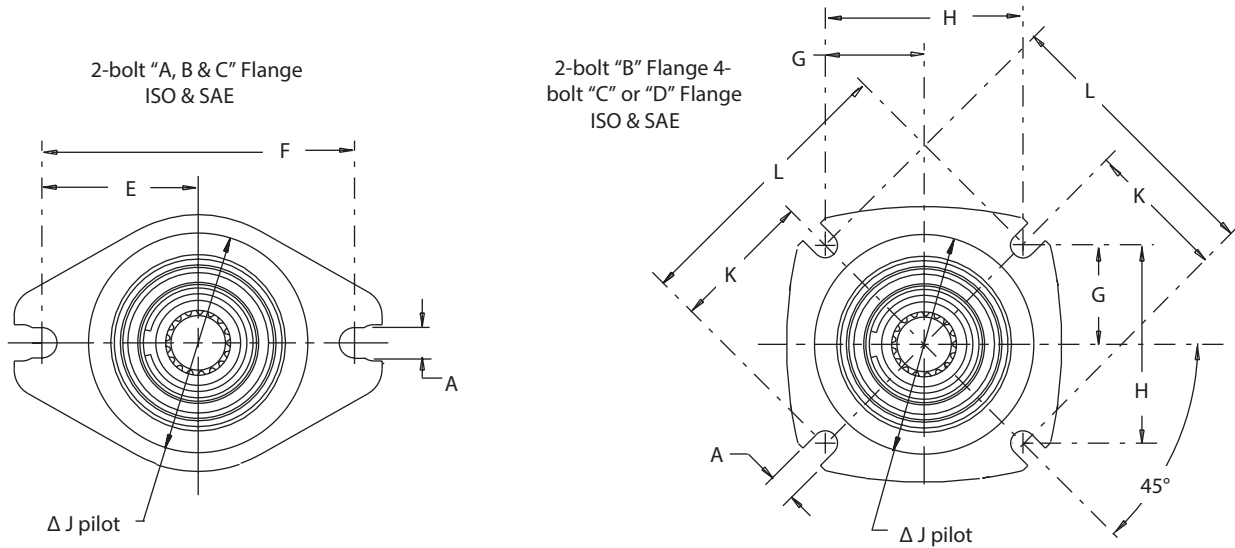

Series	2-bolt or 4-bolt Flange	Code	Flange Description	A	E	F	G	H	J	K	L
PVM018	2-bolt	A	SAE J744-82-2	Ø11,14 (4.38)	53,2 (2.09)	106,4 (4.19)	-	-	Ø82,53 +0.02 -0.03 (Ø3.249) +0.000 -0.001	-	-
PVM020	"A"										
PVM018	2-bolt	B	ISO 3019/2-80A2HW	Ø11,14 (4.38)	54,5 (2.15)	109,0 (4.29)	-	-	Ø79,98 +0.02 -0.03 (Ø3.15) +0.000 -0.001	-	-
PVM020	"A"										
PVM018 PVM020 PVM045	2-bolt	C	SAE J744-101-2	14,36 (.565)	73,0 (2.87)	146,0 (5.75)	-	-	Ø101,58+0.02 -0.03 (Ø3.999) ±.001	-	-
PVM050 PVM057 PVM063	"B"										
PVM018 PVM020 PVM045	2-bolt	D	ISO 3019/2-100A2HW	14,14 (.557)	70,0 (2.76)	140,0 (5.51)	-	-	Ø100,00/99,95 (Ø3.937/3.935)	-	-
PVM050 PVM057 PVM063	"B" (special)										
PVM057		E	SAE J744-127-2 ("C")	17,4 (.685)	90,5 (3.562)	181,0 (7.125)	-	-	Ø127,00/126,95 (Ø5.000/4.998)	-	-
PVM063	2-bolt	F	ISO 3019/2-125A2HW	18,0 (.709)	90,0 (3.543)	180,0 (7.09)	-	-	Ø125,00/124,95 (Ø4.921/4.919)	-	-
PVM074 PVM081	"C"										
PVM098 PVM106 PVM131 PVM141	4-bolt	G	SAE J744-127-4 ("C")	14,2 (.559)	-	-	57,25 (2.254)	114,50 (4.508)	Ø127,00/126,95 (Ø5.000/4.998)	-	-
	"C"	H	ISO 3019/2-125B4HW	14,0 (.551)	-	-	-	-	Ø125,00/124,95 (Ø4.921/4.919)	80,0 (3.150)	160,0 (6.299)
		J	SAE J744-152-4 ("D")	20,6 (.812)	-	-	80,82 (3.182)	161,64 (6.364)	Ø152,40/152,35 (Ø6.000/5.998)	-	-
PVM131 PVM141	4-bolt	K	ISO 3019/2-160B4HW	18,0 (.709)	-	-	-	-	Ø160,00/159,95 (Ø6.299/6.297)	100,0 (3.937)	200,0 (7.874)
	"D"										

\*Flanges for PVM020 and PVM050 are shown on pages 73 and 80, respectively.

# Shaft Options

Dimensions in millimeters (inches)

SAE Splined Shaft

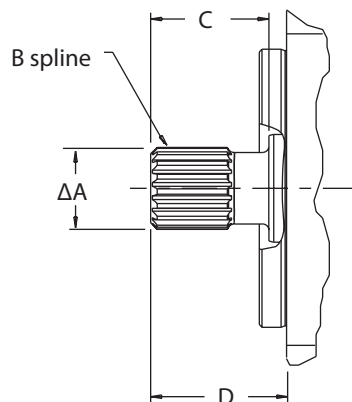

Model Series	SAE Spline Shaft Designation	Shaft Code	A max.	B	C	D	Max. Input Torque Nm (lb. in.)
PVM018/020	SAE J744-16-4 SAE "A" (9T)	03	15,88 (.625)	9T 16/32 DP	37,0 (1.46)	32,0 (1.26)	58 (517)
	SAE J744-19-4 SAE "A" (11T)	04	19,05 (.750)	11T 16/32 DP	30,0 (1.18)	38,0 (1.50)	123 (1100)
	SAE J744-22-4 SAE "B" (13T)	07	21,81 (.859)	13T 16/32 DP	33,0 (1.31)	41,0 (1.61)	208 (1850)
	SAE J744-25-4 SAE "B-B" (15T)	08	24,98 (.983)	15T 16/32 DP	38,0 (1.50)	46,0 (1.81)	337 (2987)
PVM045/050	SAE J744-22-4 SAE "B" (13T)	07	21,81 (.859)	13T 16/32 DP	33,0 (1.31)	41,0 (1.61)	208 (1850)
	SAE J744-25-4 SAE "B-B" (15T)	08	24,98 (.983)	15T 16/32 DP	38,0 (1.50)	46,0 (1.81)	337 (2987)
PVM057/063	SAE J744-22-4 SAE "B" (13T)	07	21,81 (.859)	13T 16/32 DP	33,0 (1.31)	41,0 (1.61)	208 (1850)
	SAE J744-25-4 SAE "B-B" (15T)	08	24,98 (.983)	15T 16/32 DP	38,0 (1.50)	46,0 (1.81)	337 (2987)
	SAE J744-32-4 SAE "C" (14T)	11	31,22 (1.23)	14T 12/24 DP	48,0 (1.89)	56,0 (2.20)	640 (5660)
PVM074/081 PVM098/106	SAE J744-32-4 SAE "C" (14T)	11	31,22 (1.23)	14T 12/24 DP	48,0 (1.89)	56,0 (2.20)	640 (5660)
	SAE J744-38-4 SAE "C-C" (17T)	12	37,57 (1.479)	17T 12/24 DP	54,0 (2.13)	62,0 (2.44)	1215 (10,750)
PVM131/141	SAE J744-32-4 SAE "C" (14T)	11	31,22 (1.23)	14T 12/24 DP	48,0 (1.89)	56,0 (2.20)	640 (5660)
	SAE J744-38-4 SAE "C-C" (17T)	12	37,57 (1.479)	17T 12/24 DP	54,0 (2.13)	62,0 (2.44)	1215 (10,750)
	SAE J744-44-4 SAE "D" (13T)	14	43,71 (1.721)	13T 8/16 DP	67,0 (2.63)	75,0 (2.95)	1215 (10,750)



# Shaft Options

Dimensions in millimeters (inches)

SAE Keyed Shaft

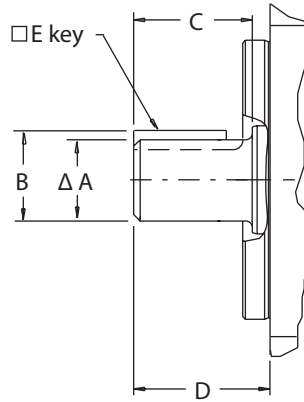

Model Series	SAE Keyed Shaft Designation	Shaft Code	A	B	C	D	E	Max. Input Torque Nm (lb. in.)
PVM018/020	SAE J744-16-1 SAE "A"	01	15,88 (.625)	17,73 (.698)	24,0 (.94)	32,0 (1.26)	4,0 (.157)	58 (517)
	SAE J744-19-1 SAE "19-1"	02	19,05 (.750)	21,23 (.836)	24,0 (.94)	32,0 (1.26)	4,81 (.189)	104 (918)
	SAE J744-22-1 SAE "B"	05	22,22 (.875)	25,12 (.989)	33,0 (1.31)	41,0 (1.61)	6,35 (.250)	135 (1200)
	SAE J744-25-1 SAE "B-B"	06	25,37 (.999)	28,22 (1.111)	38,0 (1.50)	46,0 (1.81)	6,35 (.250)	215 (1900)
PVM045/050	SAE J744-22-1 SAE "B"	05	22,22 (.875)	25,12 (.989)	33,0 (1.31)	41,0 (1.61)	6,35 (.250)	135 (1200)
	SAE J744-25-1 SAE "B-B"	06	25,37 (.999)	28,22 (1.111)	38,0 (1.50)	46,0 (1.81)	6,35 (.250)	215 (1900)
PVM057/063	SAE J744-25-1 SAE "B-B"	06	25,37 (.999)	28,22 (1.111)	38,0 (1.50)	46,0 (1.81)	6,35 (.250)	215 (1900)
	SAE J744-32-1 SAE "C"	09	31,75 (1.25)	35,32 (1.390)	48,0 (1.89)	56,0 (2.20)	7,93 (.312)	450 (3980)
PVM074/081 PVM098/106	SAE J744-32-1 SAE "C"	09	31,75 (1.25)	35,32 (1.390)	48,0 (1.89)	56,0 (2.20)	7,93 (.312)	450 (3980)
	SAE J744-38-1 SAE "C-C"	10	38,10 (1.50)	42,39 (1.67)	54,0 (2.13)	62,0 (2.44)	9,52 (.375)	765 (6770)
PVM131/141	SAE J744-32-1 SAE "C"	09	31,75 (1.25)	35,32 (1.390)	48,0 (1.89)	56,0 (2.20)	7,93 (.312)	450 (3980)
	SAE J744-38-1 SAE "C-C"	10	38,10 (1.50)	42,39 (1.67)	54,0 (2.13)	62,0 (2.44)	9,52 (.375)	765 (6770)
	SAE J744-44-1 SAE "D"	13	44,45 (1.75)	49,46 (1.95)	67,0 (2.63)	75,0 (2.95)	11,11 (.438)	1200 (10,620)

# Shaft Options

Dimensions in millimeters (inches)

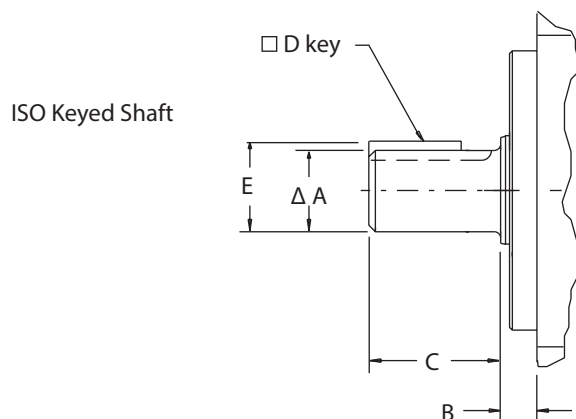

Model Series	ISO Keyed Shaft Designation	Shaft Code	A	B	C	D	E	Max. Input Torque Nm (lb. in.)
	ISO 3019/2 E20N	15	19,9 (.786)	8,5 (.335)	36 (1.42)	6 (.236)	22,5 (.886)	113 (1000)
PVM018/020	ISO 3019/2 E25N Short Spigot	16	25 (.984)	8,5 (.335)	42 (1.65)	8 (.315)	28,0 (1.102)	215 (1900)
	ISO 3019/2 E25N	17	25 (.984)	10 (.393)	42 (1.65)	8 (.315)	28,0 (1.102)	215 (1900)
PVM045/050	ISO 3019/2 E25N	17	25 (.984)	10 (.393)	42 (1.65)	8 (.315)	28,0 (1.102)	215 (1900)
PVM057/063	ISO 3019/2 E25N	17	25 (.984)	10 (.393)	42 (1.65)	8 (.315)	28,0 (1.102)	215 (1900)
	ISO 3019/2 E32N	18	32 (1.26)	10 (.393)	58 (2.28)	10 (.394)	35,0 (1.378)	450 (3980)
PVM074/081	ISO 3019/2 E32N	18	32 (1.26)	10,5 (.413)	58 (2.28)	10 (.394)	35,0 (1.378)	450 (3980)
PVM098/106	ISO 3019/2 E40N	19	40 (1.57)	10,5 (.413)	82 (3.23)	12 (.472)	43,0 (1.693)	870 (7700)
PVM131/141	ISO 3019/2 E32N	18	32 (1.26)	10 (.393)	58 (2.28)	10 (.394)	35,0 (1.378)	450 (3980)
	ISO 3019/2 E40N	19	40 (1.57)	10 (.393)	82 (3.23)	12 (.472)	43,0 (1.693)	870 (7700)

□ ISO 80mm pilot only – B □ ISO 80mm pilot only – D

\*Torque of non-thru-drive PVM pump, or combined torque of PVM thru-drive pump and thru-driven pump.

Note: In those cases where geometric tolerances of mounting are critical, or where specific tolerance ranges are required and not specified, consult Danfoss Engineering for specific limits.

# Input Shaft Selection Data

## SAE Splined Shafts

Model Series	Shaft Designation	Shaft Code	Max. Input Torque† Nm (lb. in.)	Max. Thru-drive Output Torque‡ Nm (lb. in.)
PVM018/020	SAE J744-16-4 (SAE "A," 9T)	03	58 (513)	Exceeds maximum input torque
	SAE J744-19-4 (SAE "A," 11T)	04	123 (1100)	Exceeds maximum input torque
	SAE J744-22-4 (SAE "B," 13T)	07	208 (1850)	123 (1100)
	SAE J744-25-4 (SAE "B-B," 15T)	08	337 (2987)	123 (1100)
PVM045/050	SAE J744-22-4 (SAE "B," 13T)	07	208 (1850)	208 (1850)*
	SAE J744-25-4 (SAE "B-B," 15T)	08	337 (2987)	337 (2987)
PVM057/063	SAE J744-22-4 (SAE "B," 13T)	07	208 (1850)	208 (1850)*
	SAE J744-25-4 (SAE "B-B," 15T)	08	337 (2987)	337 (2987)
	SAE J744-32-4 (SAE "C," 14T)	11	640 (5660)	337 (2987)
PVM074/081	SAE J744-32-4 (SAE "C," 14T)	11	640 (5660)	515 (4560)
PVM098/106	SAE J744-38-4 (SAE "C-C," 17T)	12	1215 (10,750)	515 (4560)
PVM131/141	SAE J744-32-4 (SAE "C," 14T)	11	640 (5660)	640 (5660)
	SAE J744-38-4 (SAE "C-C," 17T)	12	1215 (10,750)	640 (5660)
	SAE J744-44-4 (SAE "D," 13T)	14	1215 (10,750)	640 (5660)

## SAE Keyed Shafts

Model Series	Shaft Designation	Shaft Code	Max. Input Torque† Nm (lb. in.)	Max. Thru-drive Output Torque‡ Nm (lb. in.)
PVM018/020	SAE J744-16-1 (SAE "A")	01	58 (513)	Exceeds maximum input torque
	SAE J744-19-1 (SAE "19-1")	02	104 (920)	Exceeds maximum input torque
	SAE J744-22-1 (SAE "B")	05	135 (1200)	123 (1100)
	SAE J744-25-1 (SAE "B-B")	06	215 (1900)	123 (1100)
PVM045/050	SAE J744-22-1 (SAE "B")	05	135 (1200)	135 (1200)*
	SAE J744-25-1 (SAE "B-B")	06	215 (1900)	215 (1900)*
PVM057/063	SAE J744-25-1 (SAE "B-B")	06	215 (1900)	215 (1900)*
	SAE J744-32-1 (SAE "C")	09	450 (3980)	337 (2987)
PVM074/081	SAE J744-32-1 (SAE "C")	09	450 (3980)	450 (3980)*
PVM098/106	SAE J744-38-1 (SAE "C-C")	10	765 (6770)	515 (4560)
PVM131/141	SAE J744-32-1 (SAE "C")	09	450 (3980)	450 (3980)*
	SAE J744-38-1 (SAE "C-C")	10	765 (6770)	640 (5660)
	SAE J744-44-1 (SAE "D")	13	1200 (10,620)	640 (5660)

## ISO Keyed Shafts

Model Series	Shaft Designation	Shaft Code	Max. Input Torque† Nm (lb. in.)	Max. Thru-drive Output Torque‡ Nm (lb. in.)
PVM018/020	ISO 3019/2 E20N (B mount only)	15	113 (1000)	Exceeds maximum input torque
	ISO 3019/2 E25N (B mount only)	16	215 (1900)	Exceeds maximum input torque
	ISO 3019/2 E25N (D mount only)	17	215 (1900)	123 (1100)
PVM045/050	ISO 3019/2 E25N	17	215 (1900)	215 (1900)*
PVM057/063	ISO 3019/2 E25N	17	215 (1900)	215 (1900)*
	ISO 3019/2 E32N	18	450 (3980)	337 (2987)
PVM074/081	ISO 3019/2 E32N	18	450 (3980)	450 (3980)*
PVM098/106	ISO 3019/2 E40N	19	870 (7700)	515 (4560)
PVM131/141	ISO 3019/2 E32N	18	450 (3980)	450 (3980)*
	ISO 3019/2 E40N	19	870 (7700)	640 (5660)

†Maximum total torque of the thru-drive pump and the thru-driven pump(s).

‡Maximum torque that can be applied to the thru-driven pump(s).

\*This value is limited by the maximum input torque.

# Port Options

## Inlet and Outlet Ports

Model Series	Inlet/Outlet Port Option (per model code, page 5)	Port Code	Inlet Port "B"	Outlet Port "C"
PVM018/020	Inch Flange	02	SAE J518 Code 61, standard pressure. 1.25 inch diameter, .4375-14 x 1.12 bolt holes	SAE J518 Code 61, standard pressure. 0.75 inches diameter, .375-16 x .88 bolt holes
	Metric Flange	04	ISO 6162 Type II, 315 bar. 31,75mm diameter, M10 x 28 bolt holes	ISO 6162 Type II, 315 bar. 19,05mm diameter, M10 x 22 bolt holes
	Inch Tube	01	SAE J514 O-ring -20, for 1-1/4 inch O.D. tube	SAE J514 O-ring -12, for 3/4 inch O.D. tube
	Metric Tube	03	ISO 6149-1, M42 thread	ISO 6149-1, M27 thread
	British Parallel Pipe	05	ISO 228-1:1994 (E), G 1-1/4 thread	ISO 228-1:1994 (E), G 3/4 thread
PVM045/050	Inch Flange	02	SAE J518 Code 61, standard pressure. 2.00 inch diameter, .500-13 x 1.06 bolt holes	SAE J518 Code 61, standard pressure. 1.00 inch diameter, .375-16 x .87 bolt holes
	Metric Flange	04	ISO 6162 Type II, 315 bar. 51mm diameter, M12 x 27 bolt holes	ISO 6162 Type II, 315 bar. 25mm diameter, M10 x 22 bolt holes
	Inch Tube	01	SAE J514 O-ring -24, for 1-1/2 inch O.D. tube	SAE J514 O-ring -16, for 1 inch O.D. tube
	Metric Tube	03	ISO 6149-1, M48 thread	ISO 6149-1, M33 thread
	British Parallel Pipe	05	ISO 228-1:1994 (E), G 1-1/2 thread	ISO 228-1:1994 (E), G 1 thread
PVM057/063	Inch Flange	02	SAE J518 Code 61, standard pressure. 2.00 inch diameter, .500-13 x 1.06 bolt holes	SAE J518 Code 61, standard pressure. 1.00 inch diameter, .375-16 x .88 bolt holes
	Metric Flange	04	ISO 6162 Type II, 350 bar. 51mm diameter, M12 x 29 bolt holes	ISO 6162 Type, 350 bar. 25mm diameter, M10 x 23 bolt holes
	Inch Tube (End ported models only)	01	SAE J514 O-ring -24, for 1-1/2 inch O.D. tube	SAE J514 O-ring -16 for 1 inch O.D. tube
	Metric Tube (End ported models only)	03	ISO 6149-1, M48 thread	ISO 6149-1, M33 thread
PVM074/081	Inch Flange	02	SAE J518 Code 61, standard pressure. 2.00 inch diameter, .500-13 x 1.19 bolt holes	SAE J518 Code 61, standard pressure. 1.00 inch diameter, .375-16 x .88 bolt holes
	Metric Flange	04	ISO 6162 Type II, 315 bar. 51mm diameter, M12 x 20 bolt holes	ISO 6162 Type, 400 bar. 25mm diameter, M10 x 17 bolt holes
PVM098/106	Inch Flange	02	SAE J518 Code 61, standard pressure. 2.50 inch diameter, .500-13 x 1.19 bolt holes	SAE J518 Code 61, standard pressure. 1.00 inch diameter, .375-16 x .88 bolt holes
	Metric Flange	04	ISO 6162 Type I, 350 bar. 64mm diameter, M12 x 31 bolt holes	ISO 6162 Type I, 350 bar. 25mm diameter, M10 x 23 bolt holes
PVM131/141	Inch Flange	02	SAE J518 Code 61, standard pressure. 2.50 inch diameter, .500-13 x 1.19 bolt holes	SAE J518 Code 62, high pressure. 1.25 inch diameter, .500-13 x 1.00 bolt holes
	Metric Flange	04	ISO 6162 Type II, 315 bar. 64mm diameter, M12 x 31 bolt holes	ISO 6162 Type, 400 bar. 32mm diameter, M12 x 27 bolt holes

## Drain, Load Sensing, and Gauge Ports

Model Series	Inlet/Outlet Port Option (per model code, page 5)	Port Code	Drain Port "F"	Load Sensing Port "J"	Gauge Port "K"
PVM018/020	Inch Flange or Tube	01, 03	SAE J514 O-ring, .50" O.D. tube. .750-16 UNF 2B thread	SAE J514 O-ring, .25" O.D. tube. .4375-20 UNF 2B thread	SAE J514 O-ring, .25" tube. .4375-20 UNF 2B thread
	Metric Flange or Tube	03, 04	ISO 6149-1 O-ring M18 x 1,5 thread	ISO 6149-1 O-ring M12 x 1,5 thread	ISO 6149-1 O-ring M12 x 1,5 thread
	British Parallel Pipe	05	ISO 228-1:1994 (E) G 1/2 thread	ISO 228-1:1994 (E) G 1/4 thread	ISO 228-1:1994 (E) G 1/4 thread
PVM045/050	Inch Flange or Tube	01, 03	SAE J514 O-ring, .625" O.D. tube. .875-14 UNF 2B thread	SAE J514 O-ring, .250" O.D. tube. .4375-20 UNF 2B thread	SAE J514 O-ring, .375" O.D. tube. .5625-18 UNF 2B thread
	Metric Flange or Tube	03, 04	ISO 6149-1 O-ring M22 x 1,5 thread	ISO 6149-1 O-ring M12 x 1,5 thread	ISO 6149-1 O-ring M14 x 1,5 thread
	British Parallel Pipe	05	ISO 228-1:1994 (E) G 1/2 thread	ISO 228-1:1994 (E) G 1/4 thread	ISO 228-1:1994 (E) G 1/4 thread
PVM057/063	Inch Flange or Tube	01, 02	SAE J514 O-ring, .625" O.D. tube. .875-14 UNF 2B thread	SAE J514 O-ring, .375" O.D. tube. .5625-18 UNF 2B thread	SAE J514 O-ring, .375" O.D. tube. .5625-18 UNF 2B thread
	Metric Flange or Tube	03, 04	ISO 6149-1 O-ring M22 x 1,5 thread	ISO 6149-1 O-ring M14 x 1,5 thread	ISO 6149-1 O-ring M14 x 1,5 thread
PVM074/83 PVM098/106	Inch Flange	02	SAE J514 O-ring, .625" O.D. tube. .875-14 UNF 2B thread	SAE J514 O-ring, .375" O.D. tube. .562-18 UNF 2B thread	SAE J514 O-ring, .375" O.D. tube. .5625-18 UNF 2B thread
	Metric Flange	04	ISO 6149-1 O-ring M22 x 1,5 thread	ISO 6149-1 O-ring M14 x 1,5 thread	ISO 6149-1 O-ring M14 x 1,5 thread
PVM131/141	Inch Flange	02	SAE J514 O-ring, .625" O.D. tube. .875-14 UNF 2B thread	SAE J514 O-ring, .375" O.D. tube. .562-18 UNF 2B thread	SAE J514 O-ring, .375" O.D. tube. .5625-18 UNF 2B thread
	Metric Flange	04	ISO 6149-1 O-ring M22 x 1,5 thread	ISO 6149-1 O-ring M14 x 1,5 thread	ISO 6149-1 O-ring M14 x 1,5 thread

# Operating Requirements

## Inlet Pressure, Case Pressure, and Operating Temperature Requirements

Inlet Pressure			Case Pressure			Operating Temperature	
Rated Absolute bar (psi)	Minimum bar, absolute (in. Hg)	Maximum Gauge bar (psi)	Maximum Continuous bar (psi)	Maximum Intermittent bar (psi)	Peak bar (psi)	Rated °C (°F)	Maximum Intermittent °C (°F)
1,0 (14.5)	0,85 (5)	3,5 (50)	0,5 (7)	2 (30)	3,5 (50)	82 (180)	104 (220)

## Hydraulic Fluids

Fluid	Recommended Operating Viscosity Range cSt (SUS)	Maximum Viscosity at Startup cSt (SUS)	Minimum Viscosity @ Max. Intermittent Temperature of 104°C (220°F) cSt (SUS)
Use antiwear hydraulic oil, or automotive type crankcase oil (designations SC, SD, SE, or SF) per SAE J183 FEB80	16 to 40 (83 to 187)	1000 (4550)	10 (90)

For more information, see Danfoss publication 579. For operation on other alternative or environmentally friendly fluids, please contact your Danfoss Representative.

Bearing life inlet pressure at 50° C (120°F), SAE 10W oil, 1 bar abs (0 psig)

Model Series	Pressure <sub>rated</sub> bar (psi)	Speed <sub>rated</sub> rpm	Flow <sub>rated</sub> lpm (gpm)	Bearing life <sub>rated</sub> L10hours
018	315 (4568)	1800	31 (8.2)	22000
045	315 (4568)	1800	76 (20)	12500
057	315 (4568)	1800	102 (27)	9100
074	315 (4568)	1800	127 (33.5)	9000
098	315 (4568)	1800	170 (45)	11000
131	315 (4568)	1800	215 (57)	14000

Bearing life can be modified for flow, speed, and pressure using the formula:

$$L_{\text{adjusted}} = \text{life}_{\text{rated}} \times \left( \frac{\text{Pressure}_{\text{rated}}}{\text{Pressure}_{\text{adjusted}}} \right)^{3.33} \times \left( \frac{\text{Speed}_{\text{rated}}}{\text{Speed}_{\text{adjusted}}} \right) \times \left( \frac{\text{Flow}_{\text{rated}}}{\text{Flow}_{\text{adjusted}}} \right)$$

## Fluid Cleanliness

The M Series pumps are rated in anti-wear petroleum fluids with a contamination level of 20/18/13 (Danfoss) or ISO 18/13. Operation in fluids with levels more contaminated than this is not recommended. Fluids other than petroleum, severe service cycles, or temperature extremes are cause for adjustment of these codes. Please contact your Danfoss Representative for specific duty cycle recommendation.

Danfoss M Series pumps, as with any variable displacement piston pumps, will operate with apparent satisfaction in fluids up to the rating specified here. Experience has shown, however, that pump and hydraulic system life is not optimized with high fluid contamination levels (high ISO cleanliness codes).

Proper fluid condition is essential for long and satisfactory life of hydraulic components and systems. Hydraulic fluid must have the correct balance of cleanliness, materials, and additives for protection against wear of components, elevated viscosity and inclusion of air.

Essential information on the correct methods for treating hydraulic fluid is included in Danfoss publication 561 – “Danfoss Guide to Systemic Contamination Control” – Available from your local Danfoss distributor. In this publication, filtration and cleanliness levels for extending the life of axial piston pumps and other system components are listed. Included is an excellent discussion of the selection of products needed to control fluid condition.

Example: PVM131 operating at 1200 rpm, at 230 bar, and 200 lpm

From the chart, find that the rated life is 14000 L10 hours, the rated pressure is 315 bar, the rated flow is 215 lpm and the rated speed is 1800 rpm. Using the formula provided, the new bearing life expectation is calculated as follows:

$$L_{\text{adjusted}} = 14000 \times \left( \frac{315}{230} \right)^{3.33} \times \left( \frac{1800}{1200} \right) \times \left( \frac{215}{200} \right)$$

$$L_{\text{adjusted}} = 14000 \times 2.85 \times 1.5 \times 1.27$$

$$L_{\text{adjusted}} = 76010 \text{ L10 hours}$$

Further modification to bearing life are possible, including de-rating due to special fluids. Generally, standard water-glycol fluids reduce rated bearing life to 20% and caseflushing is required. Please contact Danfoss engineering for assistance.

## Moment of Inertia (single pump rotating group)

Model	Moment of Inertia	
	N-m (sec <sup>2</sup> )	lbf-in (sec <sup>2</sup> )
PVM018	0.0012	0.0104
PVM020	0.0012	0.0104
PVM045	0.0036	0.0320
PVM050	0.0034	0.0300
PVM057	0.0052	0.0457
PVM063	0.0051	0.0447
PVM074	0.0078	0.0691
PVM081	0.0073	0.0643
PVM098	0.0132	0.1165
PVM106	0.0123	0.1086
PVM131	0.0213	0.1889
PVM141	0.0210	0.1856

# Specifications and Performance

Quiet version, optimized for 1000-1800 rpm (E) and Higher speed version (M)

Alternate fluids guide

## Specifications and Performance

Fluid Type / Model Series	Petroleum Base		Motor Oil	Universal	Automatic Transmission Fluid	MI Spec Fluids	Environmentally Acceptable Fluids		Fire Resistant Fluids				Specialty Fluids	Food Grade Fluid
	ZDDP	Zinc Free		Tractor			Vegetable Base	Synthetic Base	Synthetic Base		Water Containing	Cutting Fluids	H1 - approved	
	AW (HM)	AW (HM)	UTTO	ATF		HEEG	HEES	Phosphate ester HFDR	Polyester HFDU	Polyether polyol-HFDU	Water Glycol-HFC			Invert Emulsion-HFB
1	Model series Quiet version "E" @ 1800 RPM Unless Noted													
PVM 18, PVM 45, PVM 57, PVM 74, PVM 98	4060 PSI	NR	3625 PSI **	3625 PSI **	3625 PSI **	NR	3625 PSI **	3625 PSI 1800 RPM	3300 PSI **	3300 PSI **	2500 PSI **	2250 PSI **	NR	3625 PSI **
PVM 20, PVM 50, PVM 63, PVM 81, PVM 106	3335 PSI	NR	3250 PSI **	3250 PSI **	3250 PSI **	NR	3250 PSI **	3250 PSI 1800 RPM	3000 PSI **	3000 PSI **	2250 PSI **	2000 PSI **	NR	3250 PSI **
PVM 131	4060 PSI	NR	3625 PSI **	3625 PSI **	3625 PSI **	NR	3625 PSI **	3625 PSI 1500 RPM	3300 PSI **	3300 PSI **	2500 PSI **	2250 PSI **	NR	3625 PSI **
PVM 141	3335 PSI	NR	3250 PSI **	3250 PSI **	3250 PSI **	NR	3250 PSI **	3250 PSI 1500 RPM	3000 PSI **	3000 PSI **	2250 PSI **	2000 PSI **	NR	3250 PSI **
2	Model Series Higher Speed Version (M)													
PVM 18	4060 PSI 2800 RPM	NR	3625 PSI **	2800 RPM	3625 PSI **	NR	3625 PSI **	3625 PSI 1800 RPM	3300 PSI **	3300 PSI **	2500 PSI **	2250 PSI **	NR	NR
PVM 20	3335 PSI 2800 RPM	NR	3250 PSI **	2800 RPM	3250 PSI **	NR	3250 PSI **	3250 PSI 1800 RPM	3000 PSI **	3000 PSI **	2250 PSI **	2000 PSI **	NR	NR
PVM 45	4060 PSI 2600 RPM	NR	3625 PSI **	2600 RPM	3625 PSI **	NR	3625 PSI **	3625 PSI 1800 RPM	3300 PSI **	3300 PSI **	2500 PSI **	2250 PSI **	NR	NR
PVM 50	3335 PSI 2600 RPM	NR	3250 PSI **	2600 RPM	3250 PSI **	NR	3250 PSI **	3250 PSI 1800 RPM	3000 PSI **	3000 PSI **	2250 PSI **	2000 PSI **	NR	NR
PVM 57	4060 PSI 2500 RPM	NR	3625 PSI **	2500 RPM	3625 PSI **	NR	3625 PSI **	3625 PSI 1800 RPM	3300 PSI	3300 PSI	2500 PSI **	2250 PSI **	NR	NR
PVM 63	3335 PSI 2500 RPM	NR	3250 PSI **	2500 RPM	3250 PSI **	NR	3250 PSI **	3250 PSI 1800 RPM	3000 PSI **	3000 PSI **	2250 PSI **	2000 PSI **	NR	NR
PVM 74	4060 PSI 2400 RPM	NR	3625 PSI **	2400 RPM	3625 PSI **	NR	3625 PSI **	3625 PSI 1800 RPM	3300 PSI **	3300 PSI **	2500 PSI **	2250 PSI **	NR	NR
PVM 81	3335 PSI 2400 RPM	NR	3250 PSI **	2400 RPM	3250 PSI **	NR	3250 PSI **	3250 PSI 1800 RPM	3000 PSI **	3000 PSI **	2250 PSI **	2000 PSI **	NR	NR
PVM 98	4060 PSI 2200 RPM	NR	3625 PSI **	2200 RPM	3625 PSI **	NR	3625 PSI **	3625 PSI 1800 RPM	3300 PSI **	3300 PSI **	2500 PSI **	2250 PSI **	NR	NR
PVM 106	3335 PSI 2200 RPM	NR	3250 PSI **	2200 RPM	3250 PSI **	NR	3250 PSI **	3250 PSI 1800 RPM	3000 PSI **	3000 PSI **	2250 PSI **	2000 PSI **	NR	NR
PVM 131	4060 PSI 2000 RPM	NR	3625 PSI **	2000 RPM	3625 PSI **	NR	3625 PSI **	3625 PSI 1500 RPM	3300 PSI **	3300 PSI **	2500 PSI **	2250 PSI **	NR	NR
PVM 141	3335 PSI 2000 RPM	NR	3250 PSI **	2000 RPM	3250 PSI **	NR	3250 PSI **	3250 PSI 1500 RPM	3000 PSI **	3000 PSI **	2250 PSI **	2000 PSI **	NR	NR

# Installation and Start-up

 **Warning:** Care should be taken that mechanical and hydraulic resonances are avoided in the application of the pump. Such resonances can seriously compromise the life and/or safe operation of the pump.

## Drive Data

Mounting attitude can be either horizontal or vertical, using the appropriate case drain ports to ensure that the case remains full of fluid at all times. Consult your local Danfoss Representative if a different arrangement is required.

In those cases where geometric tolerances of mounting are critical, or where specific tolerance ranges are required and not specified, consult Danfoss Engineering for specific limits.

Direction of shaft rotation, viewed from the prime mover end, must be as indicated in the model designation on the pump – either right hand (clockwise) or left hand (counterclockwise).

Direct coaxial drive through a flexible coupling is recommended. If drives imposing radial shaft loads are considered, please consult your Danfoss Representative.

## Start-up Procedure

Make sure the reservoir and circuit are clean and free of dirt/debris prior to filling with hydraulic fluid.

Fill the reservoir with filtered oil and fill to a level sufficient enough to prevent vortexing at the suction connection to pump inlet. It is good practice to clean the system by flushing and filtering, using an external slave pump.

**Caution:** Before the pump is started, fill the case through the uppermost drain port with hydraulic fluid of the type to be used. The case drain line must be connected directly to the reservoir and must terminate below the oil level.

Once the pump is started, it should prime within a few seconds. If the pump does not prime, check to make sure that there are no restrictions between the reservoir and the inlet to the pump, that the pump is being rotated in the proper direction, and that there are no air leaks in the inlet line and connections. Also check to make sure that trapped air can escape at the pump outlet.

After the pump is primed, tighten the loose outlet connections, then operate for five to ten minutes (unloaded) to remove all trapped air from the circuit.

If the reservoir has a sight gage, make sure the fluid is clear – not milky.



# Operation and Installation

## Power Control/Torque Limiter

### Description

PVM series piston pump with PowerControl consists of, A) pump with modified pressure and flow compensator and B) Power Control subassembly installed.

### Pump with Power limiter control

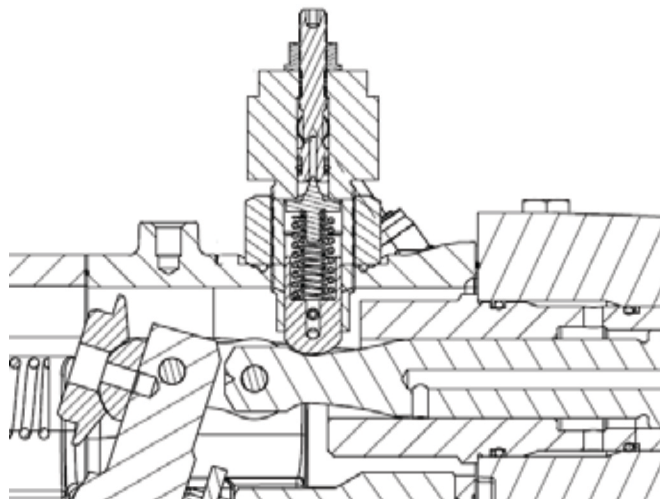
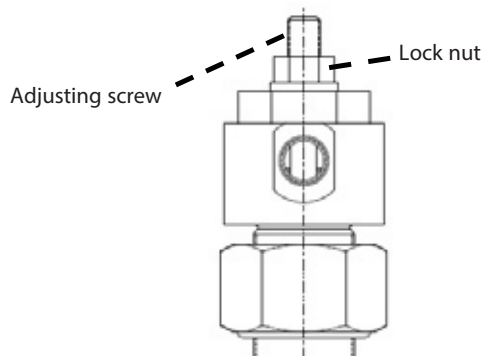
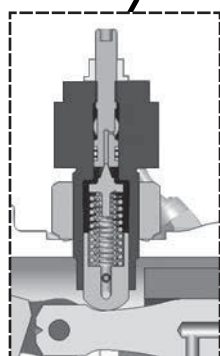
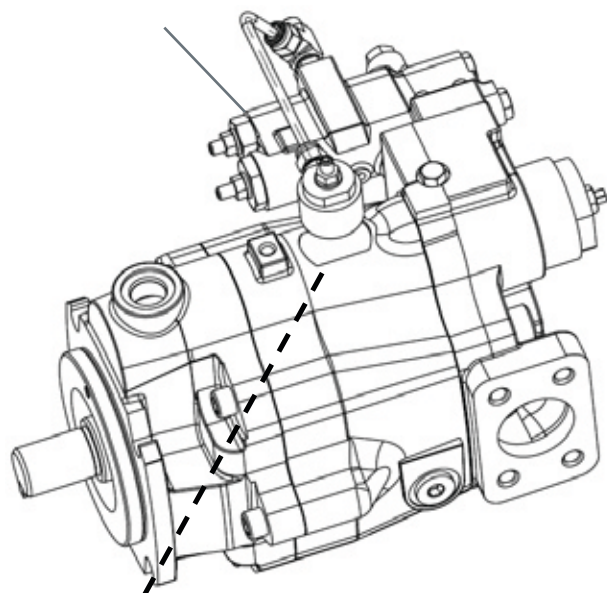

### Power Control Operation

The Power Control Subassembly consists of a poppet type valve guided by a specially designed control piston with a unique profile. The pressure setting of the poppet valve, being guided by the profile on the control piston, is dependent on the actual displacement of the pump. For lower displacement the pressure setting is high. As displacement is increased, the pressure setting is reduced according to the profile on the control piston. The poppet type valve gets pressure signal either from the modified load sense port (for Pressure Flow Compensated), or the pump outlet pressure (for Pressure Compensated). The power control subassembly regulates this pressure based on the displacement. This regulated pressure is internally fed back to the control piston chamber, which compensates by adjusting the pump displacement appropriately. This results in achieving the desired control of constant input power.

### Power Control Adjustment

To adjust the control power setting, power measurement devices are required. For Input power, motor torque and speed need to be measured, typically achieved by use of a clamp style ammeter. For output power, devices for pump pressure and flow measurements are required, such as pressure gages or transducers, and flow meters. The pump comes with factory set power setting as indicated by pos. 22, 23 of pump model code. The setting can be changed by loosening the lock nut on top of the control subassembly and turning the adjustment screw with help of a hex key. Rotating adjustment screw clockwise increases the power setting while rotating it anti-clockwise reduces it. After adjustment as required ensure that the locknut is tightened properly.





**Products we offer:**

- Cartridge valves
- DCV directional control valves
- Electric converters
- Electric machines
- Electric motors
- Gear motors
- Gear pumps
- Hydraulic integrated circuits (HICs)
- Hydrostatic motors
- Hydrostatic pumps
- Orbital motors
- PLUS+1® controllers
- PLUS+1® displays
- PLUS+1® joysticks and pedals
- PLUS+1® operator interfaces
- PLUS+1® sensors
- PLUS+1® software
- PLUS+1® software services, support and training
- Position controls and sensors
- PVG proportional valves
- Steering components and systems
- Telematics

**Hydro-Gear**

[www.hydro-gear.com](http://www.hydro-gear.com)

**Daikin-Sauer-Danfoss**

[www.daikin-sauer-danfoss.com](http://www.daikin-sauer-danfoss.com)

**Danfoss Power Solutions** is a global manufacturer and supplier of high-quality hydraulic and electric components. We specialize in providing state-of-the-art technology and solutions that excel in the harsh operating conditions of the mobile off-highway market as well as the marine sector. Building on our extensive applications expertise, we work closely with you to ensure exceptional performance for a broad range of applications. We help you and other customers around the world speed up system development, reduce costs and bring vehicles and vessels to market faster.

Danfoss Power Solutions – your strongest partner in mobile hydraulics and mobile electrification.

**Go to [www.danfoss.com](http://www.danfoss.com) for further product information.**

We offer you expert worldwide support for ensuring the best possible solutions for outstanding performance. And with an extensive network of Global Service Partners, we also provide you with comprehensive global service for all of our components.

Local address:

**Danfoss Power Solutions (US) Company**  
2800 East 13th Street  
Ames, IA 50010, USA  
Phone: +1 515 239 6000

**Danfoss Power Solutions GmbH & Co. OHG**  
Krokkamp 35  
D-24539 Neumünster, Germany  
Phone: +49 4321 871 0

**Danfoss Power Solutions ApS**  
Nordborgvej 81  
DK-6430 Nordborg, Denmark  
Phone: +45 7488 2222

**Danfoss Power Solutions Trading (Shanghai) Co., Ltd.**  
Building #22, No. 1000 Jin Hai Rd  
Jin Qiao, Pudong New District  
Shanghai, China 201206  
Phone: +86 21 2080 6201

Danfoss can accept no responsibility for possible errors in catalogues, brochures and other printed material. Danfoss reserves the right to alter its products without notice. This also applies to products already on order provided that such alterations can be made without subsequent changes being necessary in specifications already agreed. All trademarks in this material are property of the respective companies. Danfoss and the Danfoss logotype are trademarks of Danfoss A/S. All rights reserved.