

Black Bruin

No power like it.

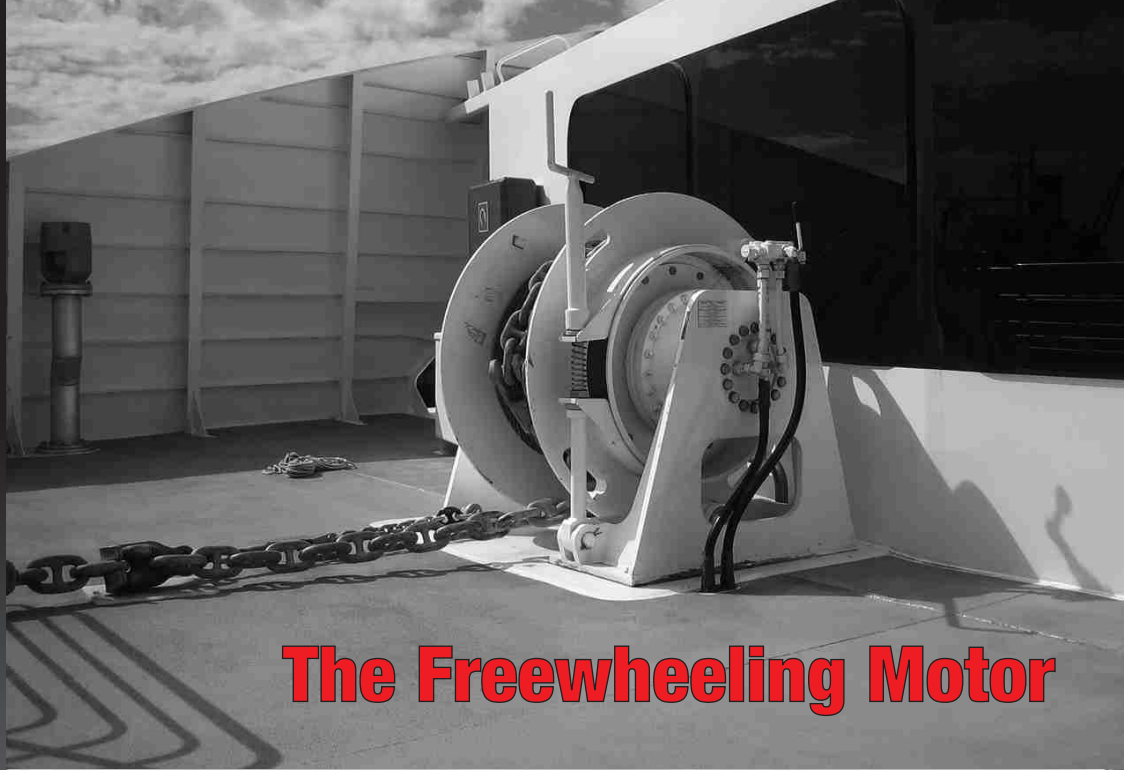

The Freewheeling Motor



Power on Demand



Customer Driven Solutions





Black Bruin BBC Motor

Radial Piston Motor with Superior Performance

Black Bruin BBC radial piston motor provides excellent efficiency up to max speeds. Multi-speed BBC motor is not restricted by preferred rotational direction and thus provides the same top performance in wide speed range to both clockwise and counter-clockwise directions. The fail-safe mechanical freewheeling with in-built freewheeling valve or 4-speed function are just couple of the many features that can be added into the versatile BBC package.

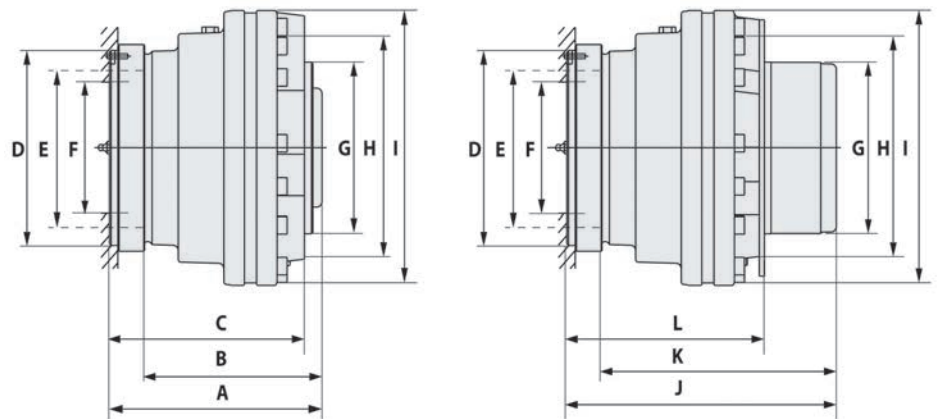

Dimensions:

Model	Weight without brake kg	A mm	Rotating part B mm	C mm	D mm	E mm	F mm	G mm	H mm	I mm	J mm	Rotating part K mm	L mm	Weight with brake kg
BBC 01	41	234	193	210	172	140 12 x M12	117	175,8	225 5 x M22 x 1,5	263	299	258	213	47
BBC 02	62	254	212	233	200	160 8 x M16	135	175,8	225 5 x M22 x 1,5	282	322	280	236	71
BBC 03	80	267,5	223	241	216	175 10 x M16	150	220,8	275 8 x M20 x 1,5	315	331	286,5	241	92
BBC 04	103	281	234	246	216	175 12 x M16	150	220,8	275 8 x M22 x 1,5	343	350	303,5	251	118
BBC 05	138	298	254	259	240	200 12 x M20 x 1,5	166	280,8	335 10 x M22 x 1,5	376	383	339	263	159
BBC 06	180	328	279,5	290	262	215 12 x M20 x 1,5	185	280,8	335 10 x M22 x 1,5	420	423	374,5	295	215
BBC 07	300	387	332,5	338	310	260 16 x M20 x 1,5	220	370,8	425 12 x M22 x 1,5	492	535	480,5	338	400

BBC MOTORS

Shaft load

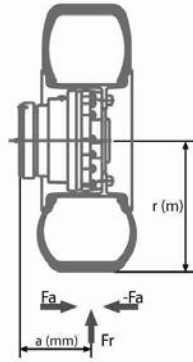

Performance curves

Nominal displacement (100%) of each frame size shown below. 90, 110, 120 and 130% displacements are also available. Please contact us for more information.

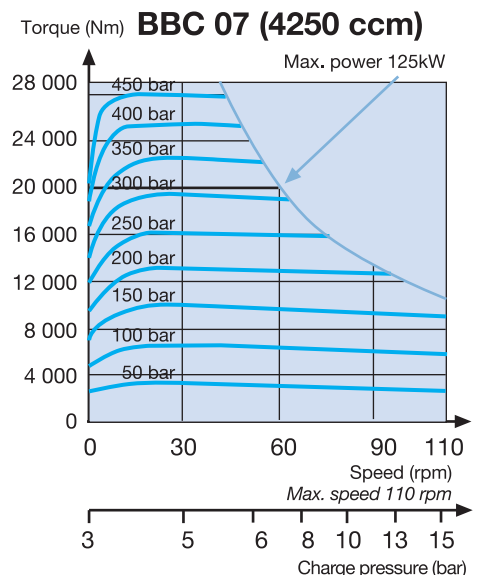
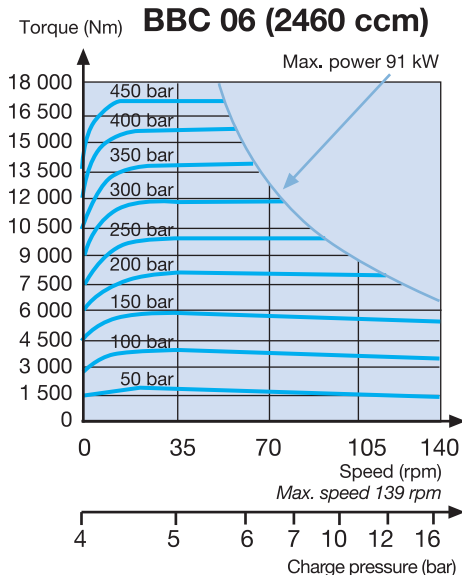
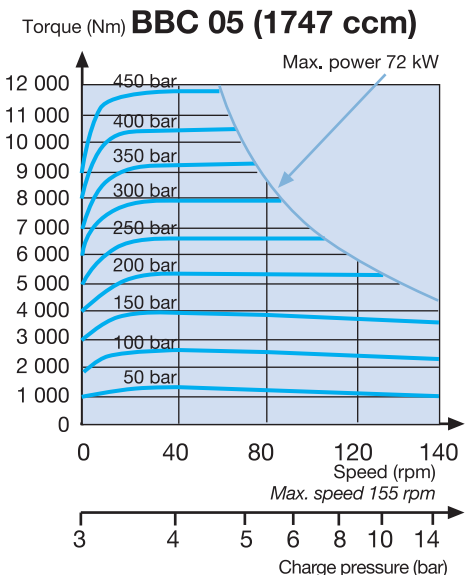
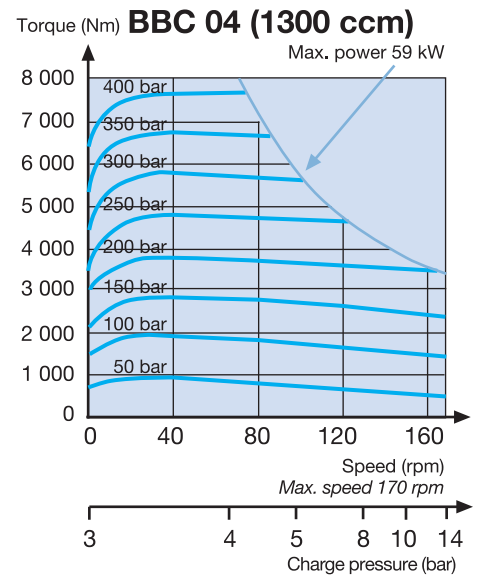
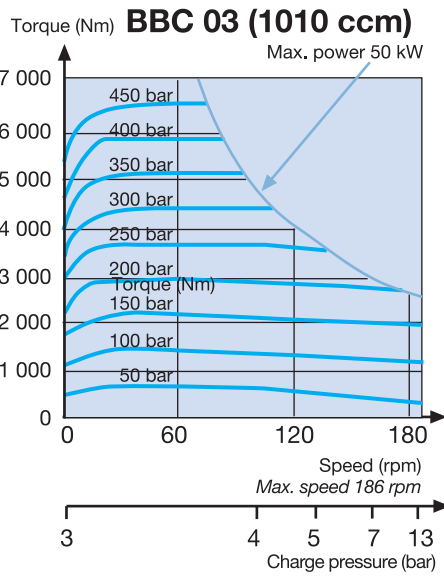
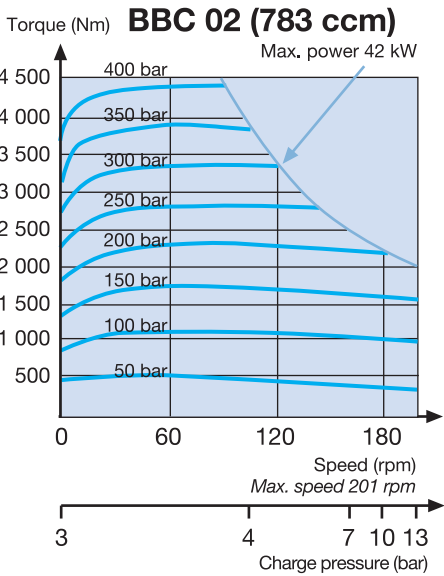
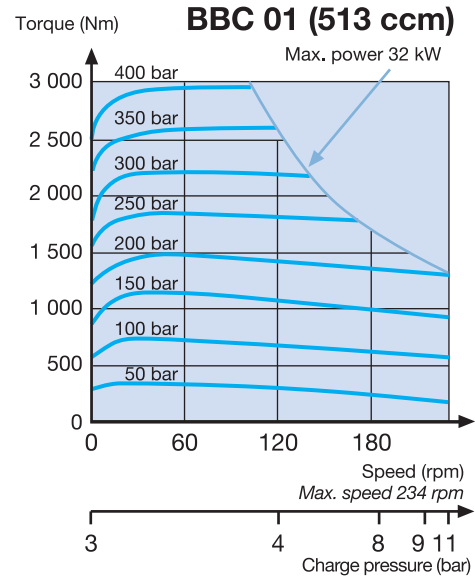
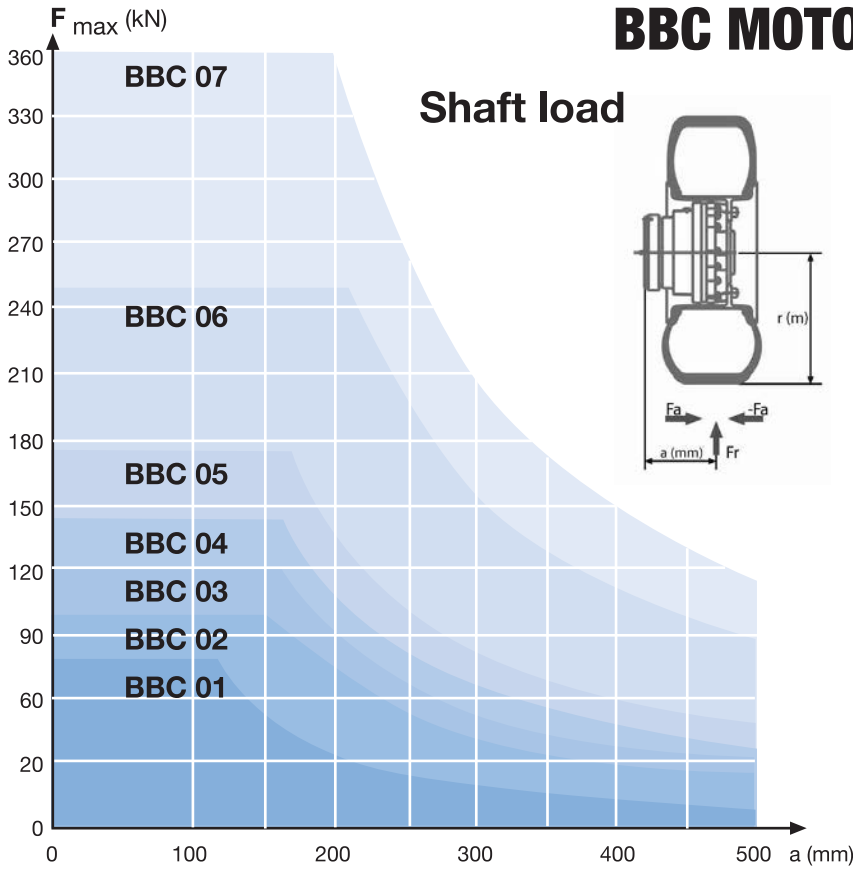

PERFORMANCE DATA

Motor frame size		BBC 01					BBC 02					BBC 03				
Percentual displacement	%	90	100	110	120	130	90	100	110	120	130	90	100	110	120	130
Displacement	ccm	462	513	564	615	667	705	783	862	940	1018	909	1010	1111	1212	1313
Peak pressure	bar	450	450	450	425	400	450	450	450	425	400	450	450	450	425	400
- Peak torque	Nm	3045	3380	3715	3830	3910	4645	5160	5680	5850	5965	5990	6655	7320	7545	7690
Intermittent* pressure	bar	400	400	400	375	350	400	400	400	375	350	400	400	400	375	350
- Intermittent torque	Nm	2710	3005	3305	3380	3420	4130	4585	5050	5165	5220	5325	5915	6510	6655	6730
Power																
- Max. displacement	kW			32					42					50		
- 1/2 displacement	kW			21					28					33		
Max. speed																
- Working	rpm	260	234	213	195	180	223	201	182	167	154	206	186	169	155	143
- 1/2 displacement	rpm	364	328	298	278	252	318	286	260	238	220	290	261	238	218	201
- Freewheeling	rpm			500					450					425		
Brake (multi-disc)																
- Brake torque	Nm			4300					6560					8470		
- Releasing pressure	bar			16					16					16		
- Max. brake pressure	bar			30					30					30		

Motor frame size		BBC 04					BBC 05					
Percentual displacement	%	90	100	110	120	130	90	100	110	120	130	
Displacement	ccm	1170	1300	1430	1560	1690		1572	1747	1922	2096	2271
Peak pressure	bar	450	450	450	425	400		450	450	450	425	400
- Peak torque	Nm	7710	8670	9425	9710	9900		10360	11515	12670	13045	13305
Intermittent* pressure	bar	400	400	400	375	350		400	400	400	375	350
- Intermittent torque	Nm	6855	7615	8380	8570	8665		9210	10235	11260	11510	11640
Power												
- Max. displacement	kW			59						72		
- 1/4, 1/2, 3/4 displacement	kW			26/39/49						32/48/60		
Max. speed												
- Working	rpm	189	170	155	142	131		172	155	141	129	119
- 3/4 displacement	rpm	225	202	184	169	156		205	185	168	154	142
- 1/2 displacement	rpm	267	240	218	200	185		244	220	200	183	169
- 1/4 displacement	rpm	356	320	291	267	246		326	293	266	244	226
- Freewheeling	rpm			425						400		
Brake (multi-disc)												
- Brake torque	Nm			10900						20600		
- Releasing pressure	bar			16						16		
- Max. brake pressure	bar			30						30		

Motor frame size		BBC 06					BBC 07				
Percentual displacement	%	90	100	110	120	130	90	100	110	120	130
Displacement	ccm	2214	2460	2706	2952	3198	3825	4250	4675	5100	5525
Peak pressure	bar	450	450	450	425	400	450	450	450	425	400
- Peak torque	Nm	14590	16215	17835	18375	18735	25200	28000	30800	31740	32360
Intermittent* pressure	bar	400	400	400	375	350	400	400	400	375	350
- Intermittent torque	Nm	12970	14410	15855	16215	16395	22400	24890	27380	28000	28310
Power											
- Max. displacement	kW			91						125	
- 1/4, 1/2, 3/4 displacement	kW			40/60/76						54/81/104	
Max. speed											
- Working	rpm	154	139	126	116	107	123	110	100	92	85
- 3/4 displacement	rpm	183	165	150	137	127	136	122	111	102	94
- 1/2 displacement	rpm	217	195	177	163	150	170	153	139	127	117
- 1/4 displacement	rpm	289	260	237	217	200	226	203	185	170	156
- Freewheeling	rpm			350					300		
Brake (multi-disc)											
- Brake torque	Nm			20600						42000	
- Releasing pressure	bar			16						16	
- Max. brake pressure	bar			30						30	

* Intermittent operation: Permissible values for max. 10 % of every minute.



Black Bruin BB Motor

The Original Freewheeling Low Speed High Torque Motor

Smooth start and excellent low speed operating characteristics in compact size. Caliber-, drum- and several multi-disc brake options. Mechanical freewheeling. Flexible engineering. A solid selection for a variety of applications.

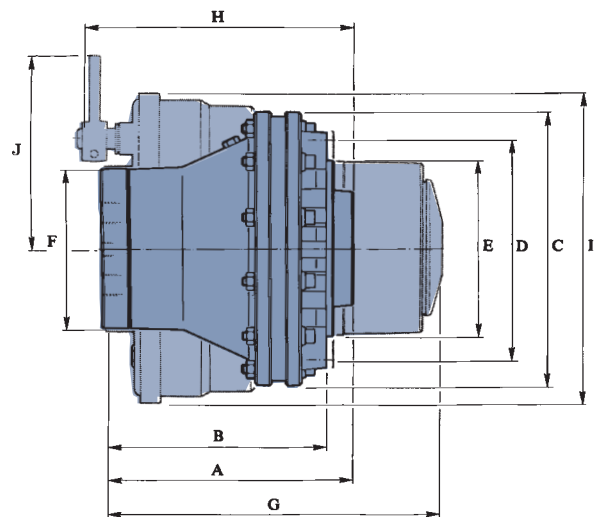

Dimensions:

Model	Weight without brake kg	Min. rim size (mm)	A mm	Without brake B mm	C mm	D mm	E mm	F mm	G mm	H mm	I mm	J Max. (mm)
BB 3	32	279,4	243	227	∅ 234	∅170 6 x M16 x 1,5	∅ 129,9	∅ 150	364	243	∅ 275	279
BB 4	50	330,2	280	262	∅ 282	∅ 205 6 x M18 x 1,5	∅ 160,8	∅ 165	420	280	∅ 334	300
BB 5	85	381	312	279	∅ 343	∅ 275 8 x M20 x 1,5	∅ 220,8	∅ 200	469	342	∅ 395	243
BB 6	145	457,2	336	317	∅ 416	∅ 335 10 x M22 x 1,5	∅ 280,8	∅ 240	480	-	-	-
BB 7	270	-	402	377	∅ 520	∅ 425 12 x M22 x 1,5	∅ 370,8	∅ 300	550	-	-	-

The data in our brochure is supplied solely for the information of the reader and does not imply any technical nor legal liability on behalf of Sampo Hydraulics. Furthermore, Sampo Hydraulics reserves the right to any technical modifications on its products, without issuing any previous warning.

BB MOTORS

Shaft load

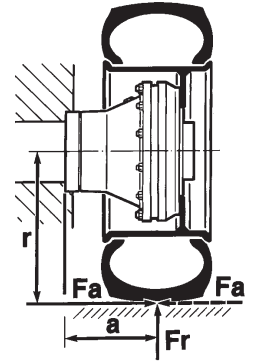
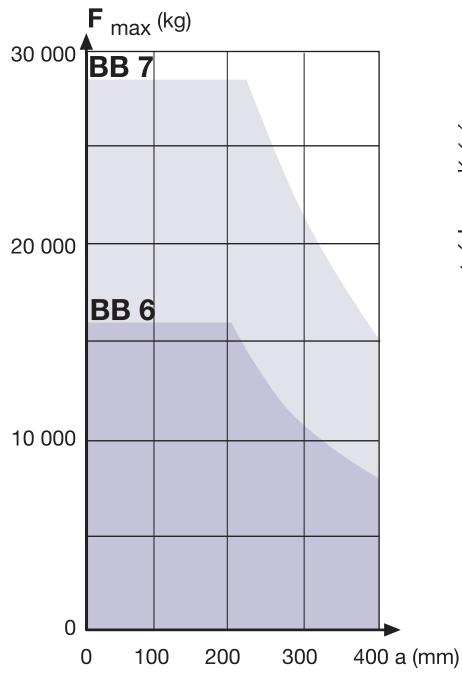
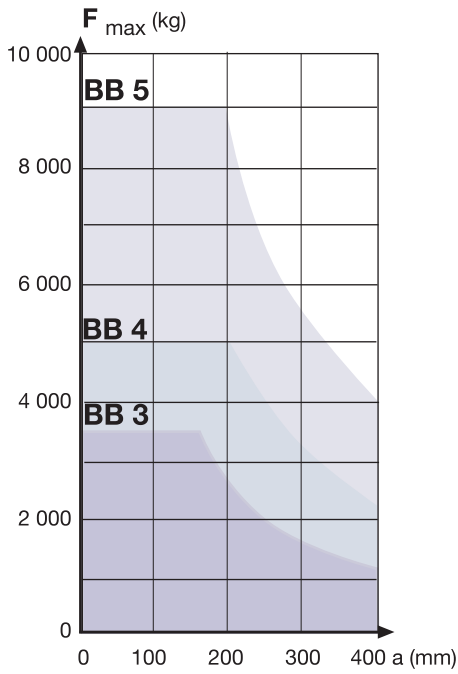

Performance curves

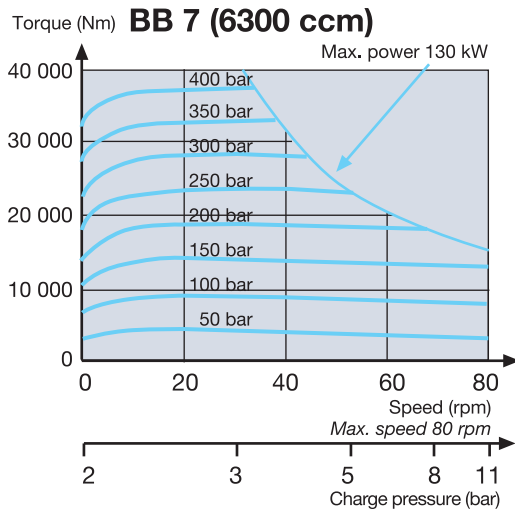
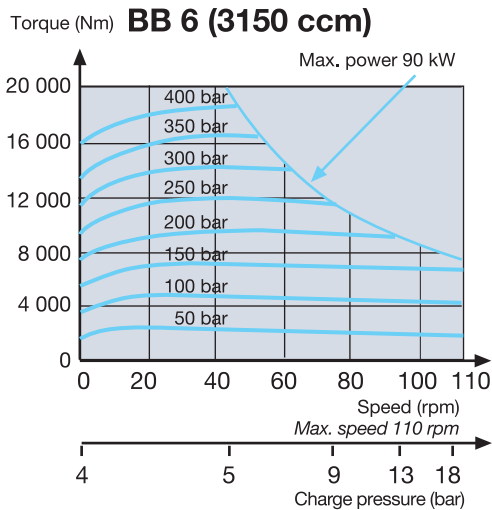
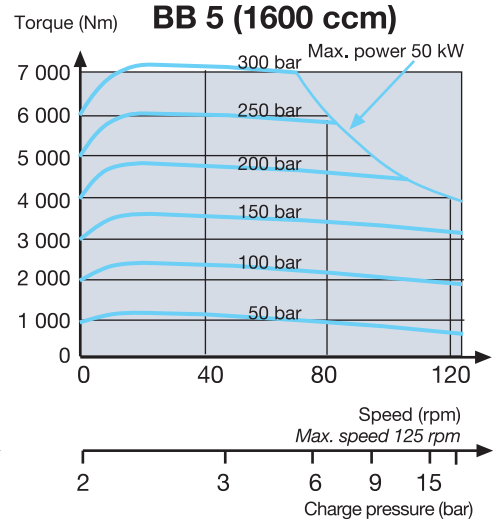
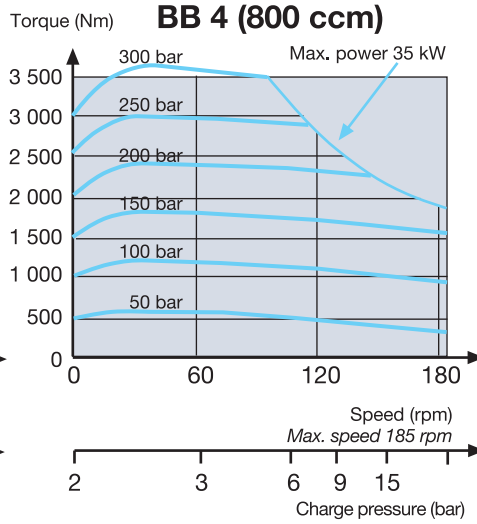
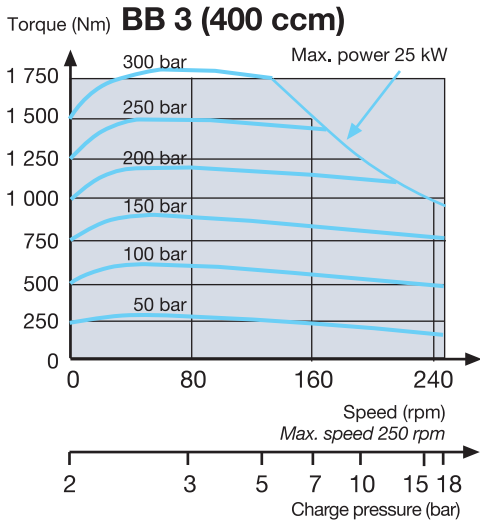

PERFORMANCE DATA

Motor frame size		BB 3			BB 4			BB 5		
Displacement	ccm	250	315	400	500	630	800	1000	1250	1600
Peak pressure	bar		350			350			350	
- Peak torque	Nm	1310	1650	2090	2620	3300	4190	5240	6540	8380
Intermittent* pressure	bar		300			300			300	
- Intermittent torque	Nm	1120	1415	1790	2245	2825	3590	4490	5610	7180
Power										
- Max. displacement	kW		25			35			50	
- 1/2 displacement	kW		13			21			30	
Max. speed										
Working	rpm	400	320	250	300	240	185	200	160	125
- 1/2 displacement	rpm	600	450	375	450	360	275	300	240	185
- Freewheeling	rpm		700			600			500	
Brake (multi disc)										
- Brake torque	Nm		2000			3700			8000	
- Releasing pressure	bar		75			70			86	
- Max brake pressure	bar		300			300			300	

Motor frame size		BB 6			BB 7		
Displacement	ccm	2000	2500	3150	4000	5000	6300
Peak pressure	bar		450			450	
- Peak torque	Nm	13440	16810	21170	26890	33530	42300
Intermittent* pressure	bar		400			400	
- Intermittent torque	Nm	11950	14940	18820	23900	29800	37600
Power							
- Max. displacement	kW		90			130	
- 1/2 displacement			54			80	
Max. speed							
Working	rpm	175	140	110	125	100	80
- 1/2 displacement	rpm	220	180	145	160	130	105
- Freewheeling	rpm		400			350	
Brake (multi disc)							
- Brake torque	Nm		20000			40000	
- Releasing pressure	bar		52			63	
- Max brake pressure	bar		250			250	

The Black Bruin Motors

The Black Bruin LSHT radial piston motor line offers two series of motors: a **classic BB** and an **advanced BBC**.

The Freewheeling Motor

Both models feature the unmatched mechanical freewheeling. This superb feature makes the Black Bruin the option to choose for any drive application requiring high freewheel speeds.

Compact Wheel Hub Motor

Being descended from a radial piston motor originally designed to be a wheel hub, Black Bruin motor is a perfect and compact fit to any wheel. Equipped with a caliber disc brake, Black Bruin offers the shortest wheel drive package with a brake in the marketplace.

Customer Driven Motors - from engineering to end users

Let our product line grow to meet Your needs: if You can not find the exact fit from our existing line of motors, bring the challenge to us and we will give our best to provide a solution for You.

stationary parts

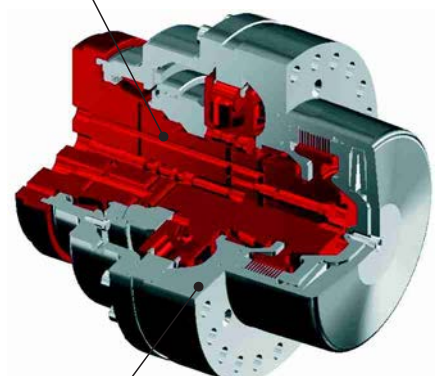

rotating parts

Customer Driven Solutions

Sampo Hydraulics Ltd. is one of the leading manufacturers of low speed high torque hydraulic motors (LSHT-motors). Over 50 years of experience in development and manufacturing of hydraulic motors guarantees the excellence of Black Bruin Motors.

Black Bruin

No power like it.



Sampo Hydraulics Ltd.
P.O. Box 633
FI-40101 Jyväskylä, Finland

Tel. +358 20 755 0755
Fax +358 20 755 0710

info@blackbruin.com
www.blackbruin.com

2013-07-04

SHAFT LOAD CALCULATION (supplement to Black Bruin Motor Brochure 2012-08-22)

Please note the shaft load chart represented in Black Bruin Motor Brochure is for total load, combination of axial and radial, applied to the motor. Please reference Black Bruin Design Guide (pages 21 and 57) or contact Representative for load calculation.

Distribution Black Bruin Representative(s)

FYI JYS_Sales