

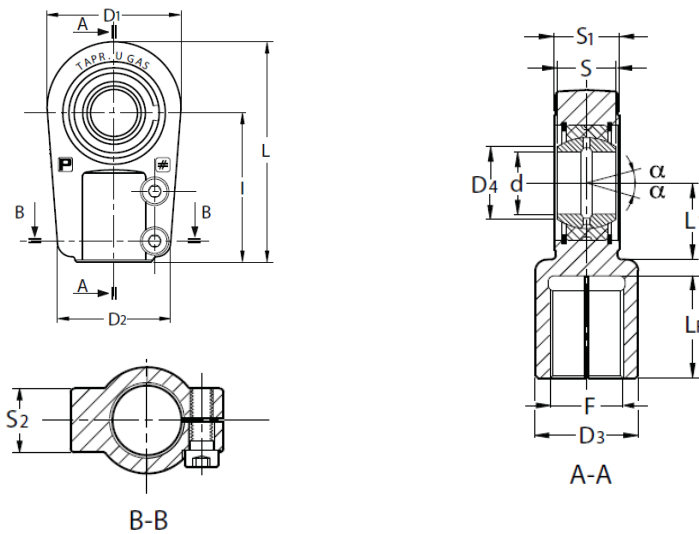

Produktbeschreibung

Gelenkkopf wartungsfrei / TAPR 100 U GAS SRT 100-2RS
(ohne Schmiernippel mit Wartungsfreier Kupplung aus Hartchrom PTFE)



TAPR 100 U GAS

d	S	D4	I	D1	D2	S1	S2	L	L1
100 mm (3.93 in)	70 mm (2.75 in)	109.5 mm (4.31 in)	275 mm (10.82 in)	230 mm (9.05 in)	188 mm (7.40 in)	70 mm (2.75 in)	65 mm (2.55 in)	400 mm (15.74 in)	105 mm (4.13 in)

D3	LF	F	Ladefaktor dynamisch	Ladefaktor statisch	Schwenk-Winkel α	Schraube K UNI 5931	Anzugsdrehmoment	Gewicht
170 mm (6.69 in)	150 mm (5.90 in)	M110x4	610 kN (62202,68 kp)	1490 kN (151937,71 kp)	7°	M20x65	300 Nm (221.23 lbf ft)	34 kg (74.95 lb)

SRT 100-2RS

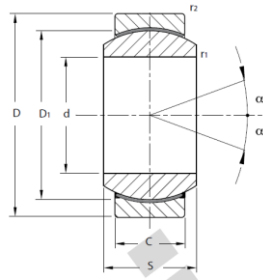

d	D	S	C	r1	r2
100 mm (3.93 in)	150 mm (5.90 in)	70 mm (2.75 in)	55 mm (2.16 in)	1.0	1.0

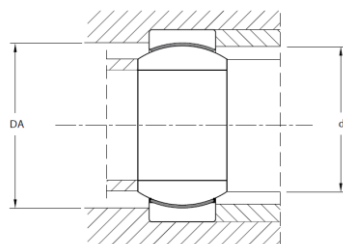

d	D1	Schwenk-Winkel α	Ladefaktor dynamisch C	Ladefaktor statisch Co	Montagedimension da max.	Montagedimension DA min.	Gewicht
100 mm (3.93 in)	130 mm (5.11 in)	7°	1725 kN (175901 kp)	2860 kN (291638 kp)	109.5 mm (4.31 in)	123 mm (4.84 in)	4.30 kg (9.47 lb)