

# EIPS2

Internal gear pumps

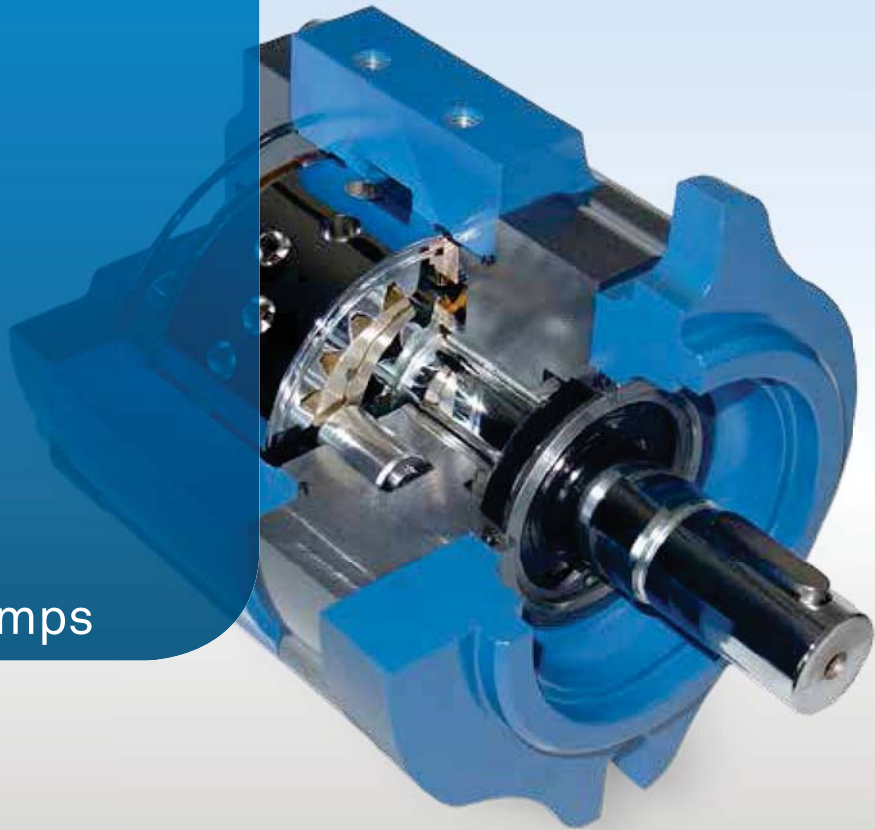

# Internal gear pump Type EIPS2 with constant displacement volume

EIPS2

## Characteristics

- Internal gear pump with axial and radial gap compensation
- Radial compensation with segments
- Pressure cover
- Field of application:  
Mobile hydraulic systems, e.g. for fork lifts, light industrial hydraulic applications
- Direct fixture
- Low noise
- Long time life
- Low pulsation (pressure pulsation ~ 2%)

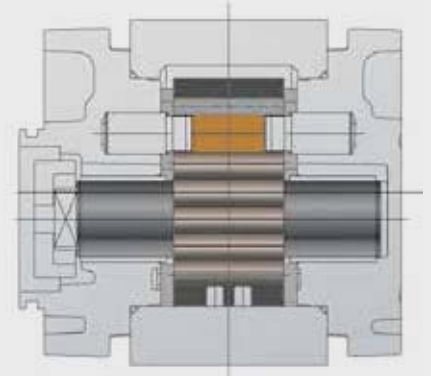
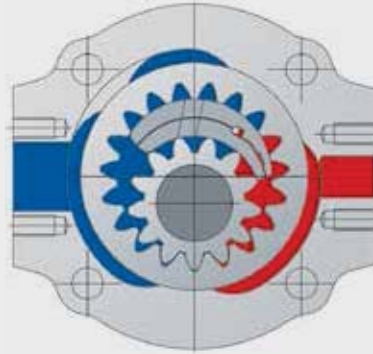

## Technical Data:

Rated Size	005	006	008	011	013	016	019	022	025
Spec. volume V <sub>th</sub> [cm <sup>3</sup> /rev]**	5,4	6,4	7,9	10,9	13,3	15,8	19,3	22,2	25,2
Continuous operating pressure [bar]	250								
Peak operating pressure [bar] max. 10 sec. 15% duty cycle				320			300		280
Cut-in pressure peak 100 ms [bar]				350			325		300
Nominal speed [min <sup>-1</sup> ]	200 – 4.000			200 – 3.600			100 – 3.000		
Max. speed [min <sup>-1</sup> ]	4.200			4.000			3.600		
Operating viscosity [mm <sup>2</sup> /s]	10 – 300								
Starting viscosity [mm <sup>2</sup> /s]	2.000								
Operating temperature [°C]	-20 to +100								
Operating medium	HL – HLP DIN 51 524 part 1/2								
Max. medium temperature [°C]	120								
Min. medium temperature [°C]	-40								
Max. ambient temperature [°C]	80								
Min. ambient temperature [°C]	-40								
Max. admission pressure (intake side) [bar]	2 bar absolute								
Min. admission pressure (intake side) [bar]	0,8 bar absolute (start 0,6)								
Weight appr. [kg]	2,9	3,0	3,1	3,3	3,5	3,6	3,8	4,0	4,2
Degree of filtration	Class 20/18/15 due to ISO 4406								
Life expectancy	not less than 1 x 10 <sup>6</sup> load cycles against peak operating pressure								
Efficiency η <sub>vol</sub> [%]	91	92	93		94		95		
Efficiency η <sub>hm</sub> [%]	90		91	92			93		
Pump noise* (measured in sound chamber) dB[A]	55	56	58	59	60	61	62	63	64

n = 1.450 min<sup>-1</sup>    Δ p = 250 bar    T = 50 °C    Medium: HLP 46

\* Measured in anechoic room of Eckerle Hydraulic Division; Axial microphone distance 1.0 m

\*\* Due to manufacturing tolerances the displacement volume could vary

The pumps have no corrosion protection. The max. permissible values must not be applied cumulatively. Please contact us.

## Pump with oldham coupling

Order example: EIPS2 - \_\_ \_LD34-1X

Size	a	b	c
005	43	82,5	72
006	44	84,5	74
008	45,5	87,5	77
011	48,5	93,5	83
013	51	98,5	88
016	53,5	103,5	93
019	57	110,5	100
022	60	116,5	106
025	63	122,5	112

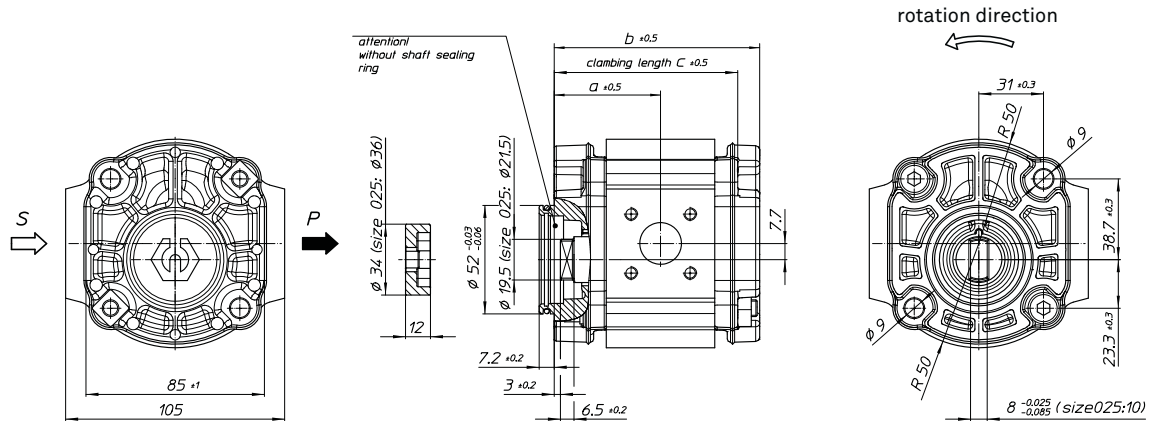

Coupling included in scope of delivery.  
Provide M8 DIN 912 fastening screws with DIN 433 plain washer, tightening torque M=25+5 Nm

## Pump with SAE-A-2-hole flange and splined shaft

Order example: EIPS2 - \_\_ \_RB04-1X

Size	a	b	d	e	f
005	62	101,5	16	24	31,5
006	63	103,5	16	24	31,5
008	64,5	106,5	16	24	31,5
011	67,5	112,5	16	24	31,5
013	70	117,5	16	24	31,5
016	72,5	122,5	16	24	31,5
019	76	129,5	16	24	31,5
022	79	135,5	22	33	40,9
025	82	141,5	22	33	40,9

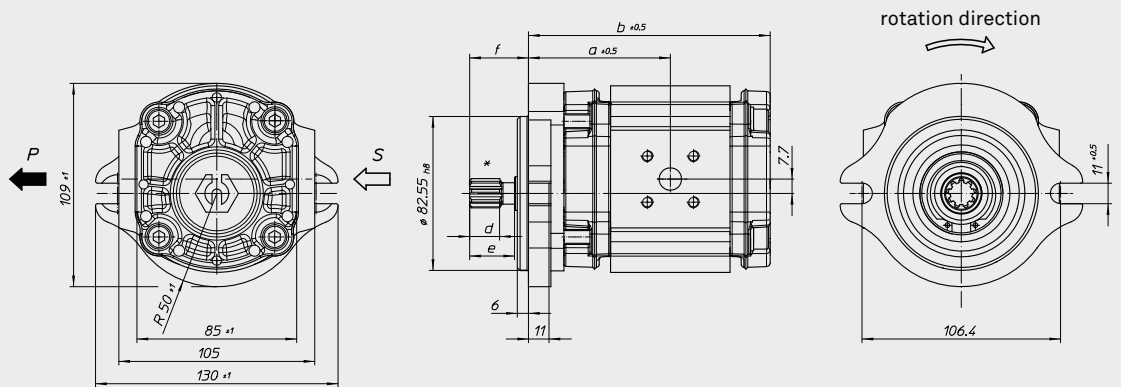

\* Size 005-019: spline ANSI B92.1 - 1996  
16/32 DP30° x 9T flatroot side fit  
Size 022 and 025: spline ANSI B92.1 - 1996  
16/32 DP30° x 13T flatroot side fit

## Pump with SAE-A-2-hole flange and cylindrical shaft

Order example: EIPS2 - \_\_ \_RA04-1X S111

Size	a	b
005	62	104,5
006	63	106,5
008	64,5	109,5
011	67,5	115,5
013	70	120,5
016	72,5	125,5
019	76	132,5
022	79	138,5
025	82	144,5

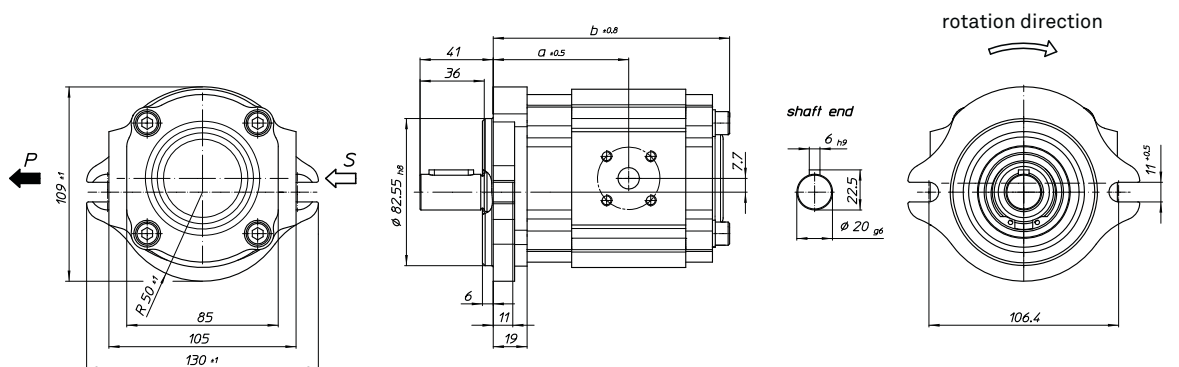

## Pump with SAE-A-2-hole flange and cylindrical shaft

Order example: EIPS2 - \_\_\_RA04-1X

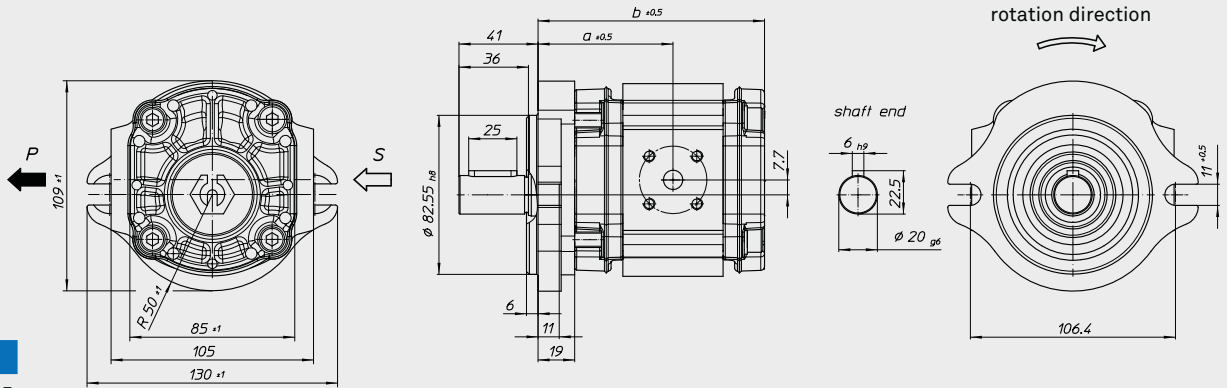

Size	a	b
005	62	101,5
006	63	103,5
008	64,5	106,5
011	67,5	112,5
013	70	117,5
016	72,5	122,5
019	76	129,5
022	79	135,5
025	82	141,5

SAE-B flange on request

## Pump with cylindrical shaft

Order example: EIPS2 - \_\_\_RA34-1X

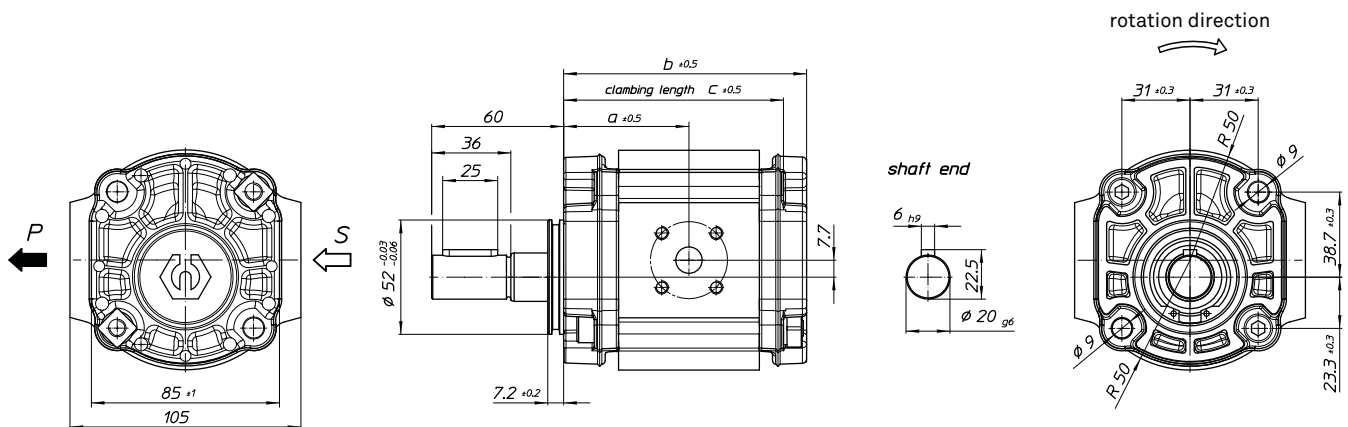

Size	a	b	c
005	43	82,5	72
006	44	84,5	74
008	45,5	87,5	77
011	48,5	93,5	83
013	51	98,5	88
016	53,5	103,5	93
019	57	110,5	100
022	60	116,5	106
025	63	122,5	112

Provide M8 DIN 912 fastening screws with DIN 433 plain washer, tightening torque M=25+5 Nm

## Double pump with SAE-2-hole flange and cylindrical shaft

Order example: EIPS2 - \_\_\_RK04-1X S111+  
EIPS2 - \_\_\_RK34-1X S111

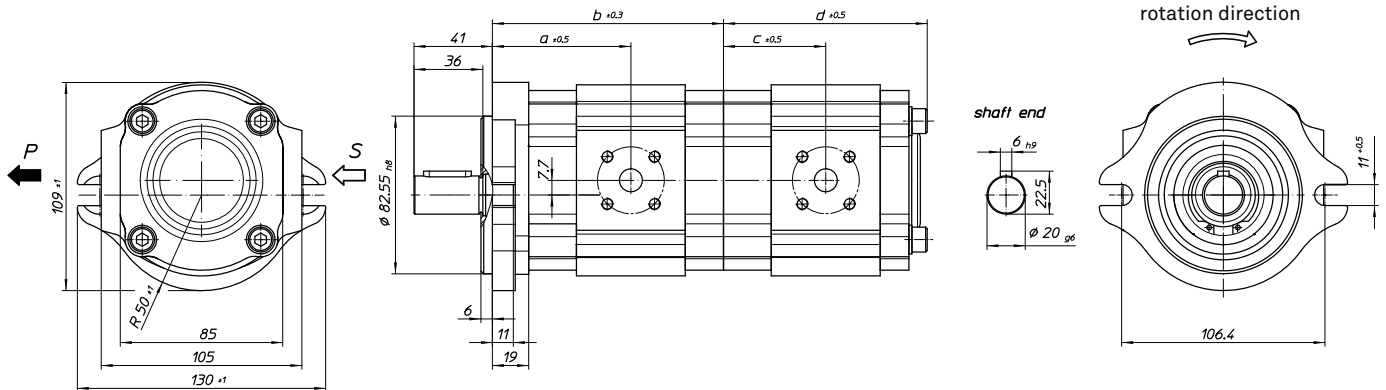

Size	a	b	c	d
005	62	100	43	85,5
006	63	102	44	87,5
008	64,5	105	45,5	90,5
011	67,5	111	48,5	96,5
013	70	116	51	101,5
016	72,5	121	53,5	106,5
019	76	128	57	113,5
022	79	134	60	119,5
025	82	140	63	125,5

## Pump with adaption, bold pattern of former Eckerle IPF 3 pumps

Order example: EIPS2 - \_\_\_LD34-1X S112

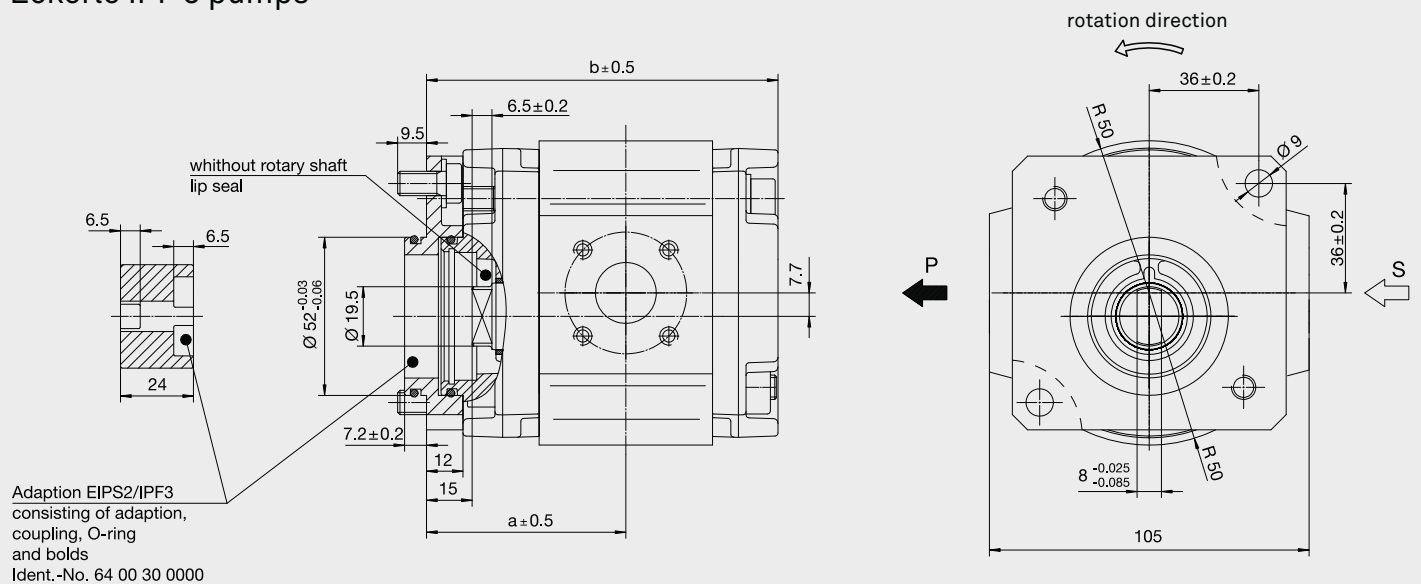

Adaption EIPS2/IPF3  
consisting of adaption,  
coupling, O-ring  
and bolts  
Ident.-No. 64 00 30 0000

Size	a	b
011	60,5	105,5
013	63	110,5
016	65,5	115,5
019	69	122,5
022	72	128,5

## Flange connection 90° – 24° DIN 3901

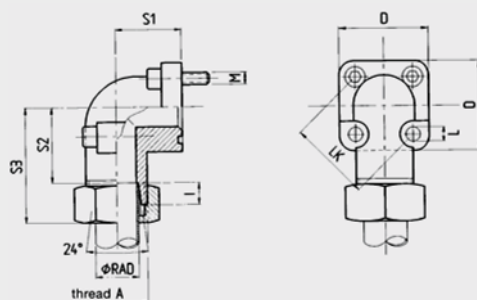

Type	Article number	LK	A	RAD	D	S1	S2	S3	L	Bolts	O-Ring	Weight	p max
WV-AD 12/35LK-C	0707040013	35	M18x1,5	L12	39	16,5	30,5	47	6,4	2xM6x22 2xM6x35	20x2,5	0,13	315 bar
WV-AD 16/35LK-C	0707040014	35	M24x1,5	L16	39	20	29,5	48	6,4	2xM6x22 2xM6x40	20x2,5	0,17	315 bar
WV-AD 28/40LK-C	0707040015	40	M36x2	L28	42	28	32,5	49	6,4	2xM6x22 2xM6x50	26x2,5	0,27	100 bar
WV-AD 35/55LK-C	0707040016	55	M45x2	L35	58	32	38,5	62	8,4	2xM8x25 2xM8x60	32x2,5	0,46	100 bar

## 4-hole flange 90° BSPP-threaded steel

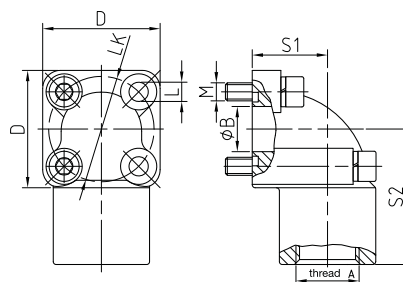

Type	Article number	LK	A	B	D	S1	S2	L	Bolts	O-Ring	Weight	p max
WV-G3/8-35LK-C	0707040021	35	G3/8"	15	39	25	45	6,4	2xM6x22 2xM6x45	20x2,5	0,27	315 bar
WV-G1/2-35LK-C	0707040022	35	G1/2"	15	39	25	45	6,4	2xM6x22 2xM6x45	20x2,5	0,25	315 bar
WV-G3/4-40LK-C	0707040023	40	G3/4"	20	42	28	50	6,4	2xM6x22 2xM6x50	26x2,5	0,38	160 bar
WV-G1-55LK-C	0707040025	55	G1"	26	58	40	59	8,4	2xM6x25 2xM6x70	32x2,5	0,87	160 bar

## Flange connection – straight 24° DIN 3901

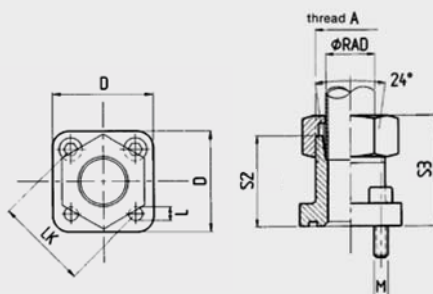

Type	Article number	LK	A	RAD	D	S2	S3	L	Bolts	O-Ring	Weight	p max
V-AD 12/35LK-C	0707040017	35	M18x1,5	L12	39	30	39	6,4	4xM6x22	20x2,5	0,09	315 bar
V-AD 16/35LK-C	0707040018	35	M24x1,5	S16	39	30	39,5	6,4	4xM6x22	20x2,5	0,11	315 bar
V-AD 28/40LK-C	0707040019	40	M36x2	L28	42	42	44,5	6,4	4xM6x22	26x2,5	0,16	100 bar
V-AD 35/55LK-C	0707040020	55	M45x2	L35	55	50	61	8,4	4xM8x25	32x2,5	0,3	100 bar

# Intake and outlet connections/ Ordering code

EIPS2

## Intake and outlet connections

### Intake connection

Size 005–016

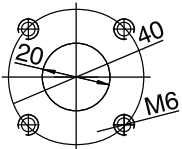

Size 019–025

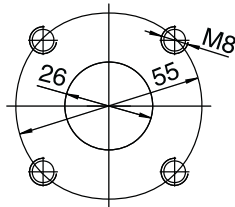

### Outlet connection

Size 006–025

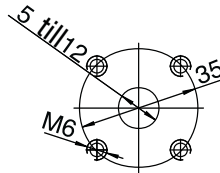

Thread depth M6 and M8 = 12 mm  
All dimensions stated in mm

– other connections on request –

EIP S2 - 011 RA34 - 10 S111

#### Special version number

For example: S111 light industrial version

#### Revision code

1st number: Change of mounting dimensions

2nd number: Change of pump with same mounting dimensions

#### Intake and outlet connection

4: Square flanged connection  
in accordance with DIN 3901/3902  
– other connections on request –

#### Fastening flange

0: SAE-A-2-hole centring collar Ø 82,55

2: SAE-B-2-hole centring collar Ø 101,6

3: Direct fixture

– other flanges on request –

#### Shaft end

A: Cylindrical

K: Cylindrical with spigot

B: SAE gear

L: SAE gear with spigot

D: Two-flange

N: Two-flange engagement

engagement

with spigot

(spigot = add-on facility for additional pumps  
to create multiple-flow pumps)

#### Rotation direction

R: Clockwise | L: Anticlockwise

#### Rated size

Three digits

#### Overall size

#### Type

S: Segmental pump

#### Eckerle internal gear pump

#### Order example

EIPS2 - 005 LD34 - 1X

Segmental pump overall size 2 with 5.4 cm<sup>3</sup>/rev., anti-clockwise rotation, two-flange engagement, direct fixture, square flange connection, revision code 10

## Volume flow

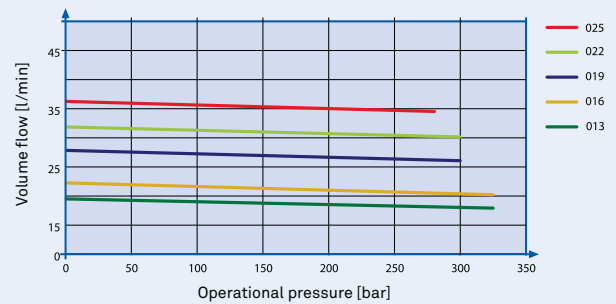
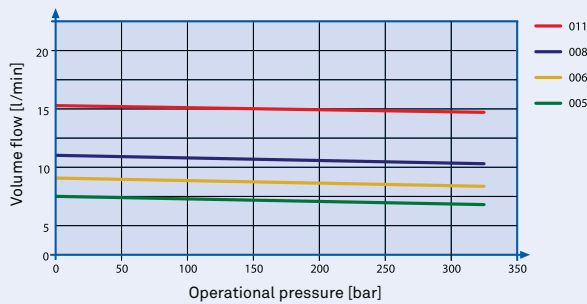

## Level of efficiency

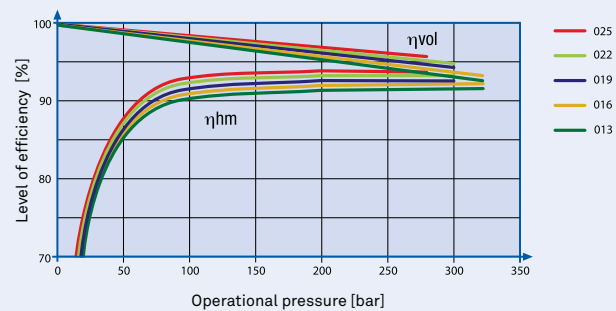
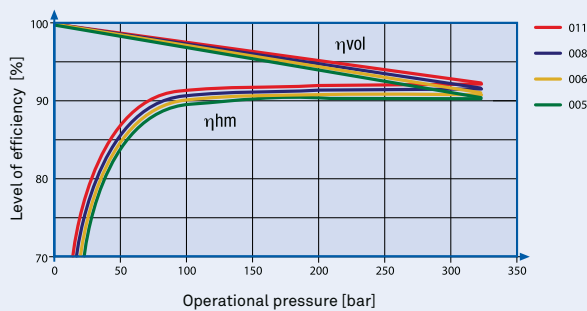

## Driving power

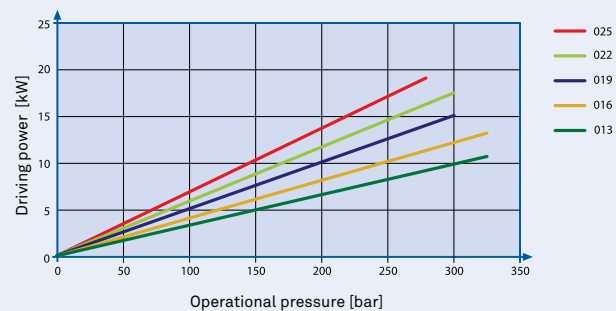
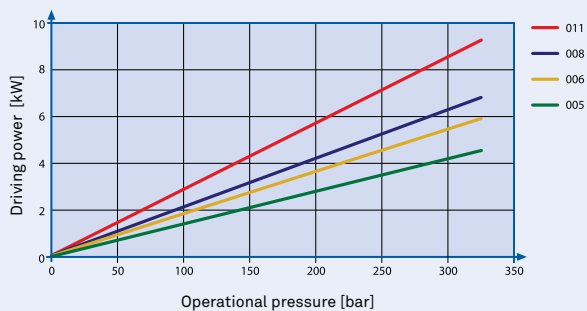

## Sound level pressure in air

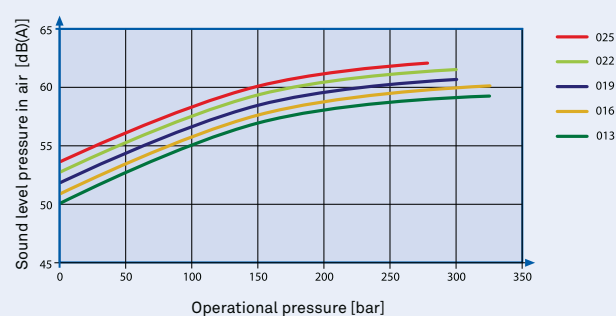
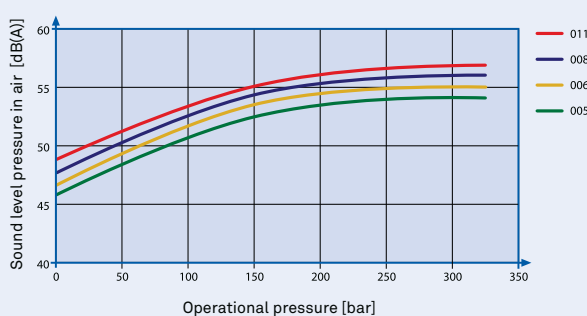

Measurement conditions: Speed 1450 rpm, viscosity 46 mm<sup>2</sup>/sec., operating temperature 40 °C, Sound pressure measured in low-reflection anechoic room in accordance with DIN 45 635 sheet 26; Microphone distance 1.0 m axial.

available at::

sales@atphydraulik.ch  
atphydraulik.com



Eckerle Technologies GmbH · P.O. box 1368  
Otto-Eckerle-Strasse 6/12A · D-76316 Malsch · Germany  
Phone +49 (0) 7246 9204-0 · sales.ehd@eckerle.com · www.eckerle.com

All indicated data serve alone the product description and are not as characteristics in the legal sense to be understood. Subject to alterations.

# eckerle