



### CONFIGURABLE

Simple, safe & fast setup  
via free Bluetooth app within a  
30-foot-radius

### RUGGED

Designed for extreme  
environmental conditions for the  
mobile hydraulic industry

### UNIVERSAL

Use with any electro-proportional  
or solenoid-operated on/off valves



# XMD-01/-02

## BLUETOOTH-CONFIGURABLE ELECTRO-HYDRAULIC DRIVERS, CAN CAPABLE

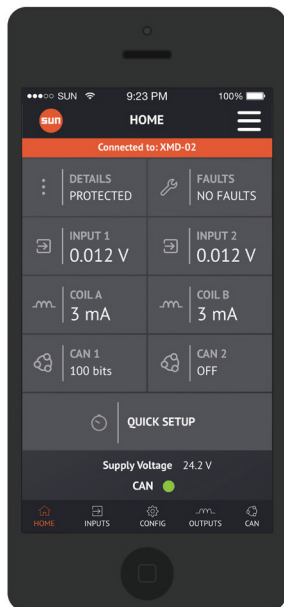

XMD Mobile App



### TABLE OF CONTENTS

<b>XMD Overview</b>	<b>2</b>
<b>Technical Specifications</b>	<b>3</b>
<b>Equipment Installation</b>	<b>4</b>
<b>LED Operation</b>	<b>5</b>
<b>Capabilities</b>	<b>6</b>
<b>Accessories</b>	<b>8</b>

[sunhydraulics.com/models/electronics/i-o-modules/xmd-series](http://sunhydraulics.com/models/electronics/i-o-modules/xmd-series)

# SUN XMD Series

*Exceptional Sun performance at a competitive price*

## XMD Intended Use

The XMD module is an electro-hydraulic driver for use with mobile and industrial hydraulic equipment.

Configurable using Sun’s FREE XMD Mobile app readily available worldwide for control of electrically operated hydraulic actuators used in many applications for on- and off-highway equipment including but not limited to agriculture, forestry, construction, marine, earth moving, and material handling.

Tuned for optimal flow and pressure control using Sun valves, the XMD driver delivers repeatable and reliable solutions for your application demands.

 Please read and observe any precautions wherever this symbol is used in this document.

## XMD Features

### SAE J1939 CAN Communication

Configure CAN sensors and joysticks as inputs or configure as a remote node to be used with any CAN-capable programmable controller or display. The XMD is also designed to transmit the analog universal inputs as CAN messages for enhanced intelligence and diagnostic information.



CAN Capable Display

### Quick Setup Profiles

Select between single- and dual-coil pre-defined profiles for typical pressure and flow configurations for fast, reliable solutions.

### Diagnostic Mode

Allows technicians worldwide to access alarm and operational conditions without editing password-protected engineered settings.

### Input/Output Function Curves

Create a custom output curve for finely tuned joystick control or custom flow/pressure curves with the use of the universal inputs and CAN-received messages.



Quick Setup

Diagnostic Mode



Input / Output Curves

## Operational Specifications

Supply Voltage	9 - 32 Vdc
Supply Current	XMD-01: 3 A max
	XMD-02: 6 A max
Weight	0.3 lbs (0.136 kg)
Dimensions (L x W x H)	3.38 in x 2.30 in x 1.40 in (85.87 x 58.49 x 35.62 mm)
Enclosure	PBT, 30% glass-filled
IP Rating	IP69K
Certification	CE, E-Mark, E11 10R-05100024 2014/53/EU (Radio Equipment Directive), 2014/35/EU (Low Voltage Directive)

## Communication

CAN	2.0B (Maximum voltage + 32 Vdc)
Baud Rates	125 kbit/s, 250 kbit/s, 500 kbit/s, 1 Mbit/s
Default Baud Rates	250 kbit/s
Protocol	SAE J1939

### Notes:

- 1) No HAZARDOUS LIVE parts are present in the equipment. Terminals are rated to 32 Vdc maximum.
- 2) Recommended supply voltage 12 Vdc or 24 Vdc with negative to earth. 6Vdc protection for engine cranking events.
- 3) Use twisted or twisted shielded-pair cable for CAN per the applicable standard.

## Inputs

Universal Inputs	XMD-01 (1 universal input)	0 - 5 Vdc, 0 - 10 Vdc, 4-20 mA, digital, frequency (60 Hz-10 kHz), PWM (60 Hz -10 kHz), resistive (0 - 100 kΩ), software configurable
	XMD-02 (2 universal inputs)	
Input Range	Current Input Mode: 0 to +20 mA. Maximum allowable current: +22 mA (impedance Z = ~200 Ω). Active circuit protection above 22 mA and limited to 32 V. Digital Input: 0 to +Supply, not to exceed 32 Vdc (impedance Z = ~10 kΩ). Digital Input: Debounce time 200 ms fixed in device firmware. Maximum voltage on any input pin +32 Vdc and -0.7 Vdc.	

## Outputs

PWM Outputs	XMD-01 (1 PWM output)	0-3.0 Amps Peak -40°C + 75°C continuous per channel 0-2.7 Amps Peak +75°C + 85°C continuous per channel
	XMD-02 (2 PWM outputs)	
Current Regulation	± 1mA above 35 mA	
PWM Frequency	33 Hz - 5 kHz	
Dither Frequency	33 Hz - 500 Hz	
Dither Amplitude	0 - 25% of PWM Period	
Diagnostics	Open/short-circuit detection	
Flyback Protection	Integrated diode protection	
Ramp Time	0 - 65 seconds, 1-mS increments	
Reference Output	5 Vdc, ±0.1 Vdc (250 mA max.)	

## Environmental

Operating Temperature	-40°C to +85°C (-40°F to +185°F)	Vibration	33.3 Hz 6.8g Peak (Spec: S-367 Section 11.0)
Storage Temperature	-60°C to +120°C (-76°F to +248°F)	Shock	49g Peak (Spec: S-367 Section 12.0)
EMC/EMI	EN 55024, EN 55032, EN 13309, EN/ISO 14982, ISO 13766, ISO 16750-2, J1113-4/11/12/13/26, ISO 1142-2/10, CISPR 25, FCC 15B, ICES-003, UNECE Reg 10.5, EN 61326-1:2013, EN 301 489-1 V2.2.0, EN 301 489-17, EN 12895		

## Patent

Patent Number	Patent Pending
---------------	----------------

## Equipment Installation

The XMD drivers should be installed and operated by a competent electrician, technician or engineer. Improper installation and use of these products can result in significant threat to both individuals and equipment. In the event of an equipment breakdown, do not attempt to repair the driver as there are no user-serviceable parts inside the product. Evidence of tampering will invalidate the warranty.

### Wiring Pin Out

Pin	XMD-01 /-02 Description
1	CAN_LO
2	CAN_HI
3	GND (Inputs, Outputs & 5Vref)
4	XMD-01 No Connection XMD-02 PWM Output, Coil B
5	GND (Inputs, Outputs & 5 Vref)
6	PWM Output, Coil A
7	Supply GND
8	Supply PWR
9	Enable
10	+5 Vref (250 mA max)
11	Universal Input 1
12	XMD-01 No Connection XMD-02 Universal Input 2

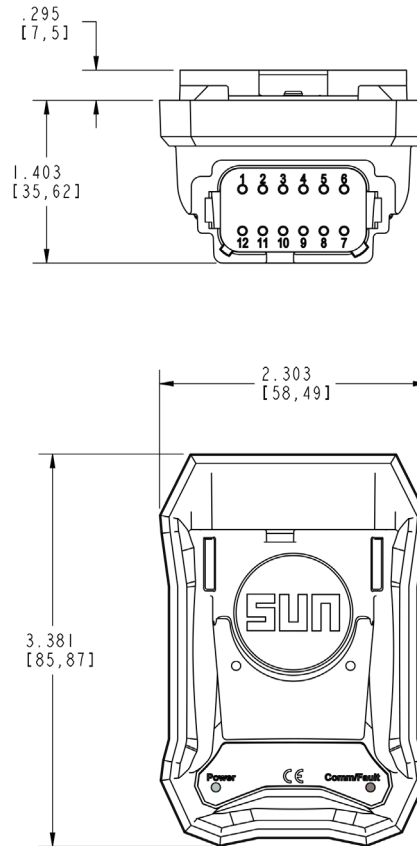

### Recommended Wiring Practices:

- 1) For best grounding practices, isolate pin 7, supply ground, from pins 3 and 5, command, +5Vdc reference, and output grounds.
- 2) Use twisted or twisted shielded-pair cable for CAN per the applicable standard.
- 3) Confirm that the CAN network is properly terminated using 120-Ω resistors.
- 4) Make certain that the harness is designed and constructed to minimize induced interference resulting from EMI coupling between signal wires.
- 5) Keep high-voltage AC cables separate from low-voltage DC signal and supply cables.
- 6) Check ALL wire connections to and from this unit to ensure NO short or open circuits are present.
- 7) Ensure that any unused wires/connections are terminated safely and not shorted together.
- 8) Isolate the amplifier if any battery charging or battery boosting takes place on the installation.
- 9) Follow and abide by all applicable health and safety standards – protect yourself and others.
- 10) Never disconnect or connect wires to or from this unit unless it is isolated from the power supply.
- 11) Use best practice wiring standards

### Mechanical Installation:

The controller should be mounted on a flat surface. Provide sufficient clearance from moving parts.

- 1) Recommend mounting hardware: #8-32 x 1/2 T18-8 stainless screws, suggested torque 22 in-lbf
- 2) Do not mount in a location that will result in ambient temperatures greater than specified operational temperature limits.
- 3) The XMD is compatible with standard 35-mm DIN Rail.

**!** A 10A ATC or ATO fuse is required to be installed ahead of the equipment.

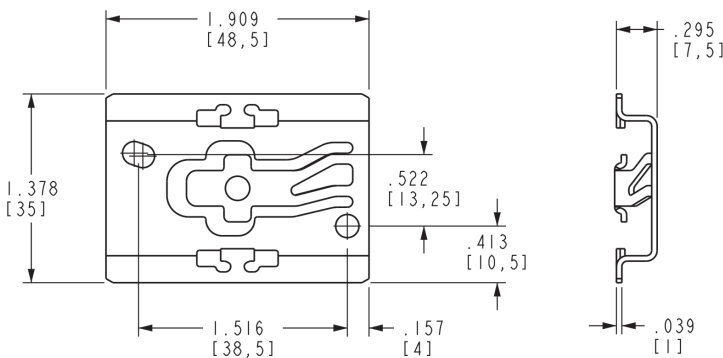

Installation Bracket

### Notes:

- 1) Use size 16 contact sockets for wire sizes: 16, 18, and 20 AWG.
- 2) Use crimp tool: HDT-48-00
- 3) Compatible with any DT06-12SA-XXX mating connector
- 4) Preferred mating connectors:
  - DT06-12SA
  - DT06-12SA-P012
- 5) Use standard Deutsch back shell for IP69K rating, DT12S-BT



### Warning: Prior to welding

In order to avoid damage to the product, ensure that all electrical connections are fully disconnected from the XMD driver prior to welding on the machine.

## LED Operation



Power LED Operation		
Mode of Operation	Status	Description
Normal Operating mode, no faults		ON GREEN
Supply Voltage Below 9VDC		ON Red
Supply Voltage Above 32VDC		Blink / Red - 1 blink ON/ pause OFF 500 ms

Comm / Fault LED Operation		
Mode of Operation	Status	Description
Normal Operating mode, OFF		OFF
Connected to mobile phone app / Configuration Mode		Blink/Green - 1 blink 125 ms ON/OFF 500 ms
Receiving CAN messages		Blink / Green – 2 blinks 125 ms ON/ pause OFF 500 ms
CAN Message Timeout		Blink / Red – 2 blinks 125 ms ON/pause OFF 500 ms
Coil Short, ON RED		ON/Red
Coil Open		Blink/Red - 3 blinks 125 ms ON/ pause OFF 500 ms
Command % out of range		Blink/Red - 1 blink ON/ pause OFF 500 ms

- If the equipment is used in a manner not specified by the manufacturer, the protection by the equipment may be impaired.
- This unit is intended only for connection to vehicle electrical systems and voltage above the identified ratings should never be connected to the unit.
- The +5V reference, pin 10, is intended to source stable voltage to external equipment and must not be connected to +Supply Power or Ground, or permanent damage to the XMD will result.
- This equipment has not been investigated as a safety rated component and shall not be relied upon as a safety device. Separate emergency stop equipment must be integrated on the machine in accordance with the machinery directive. The operator of the equipment shall always be in sight of the controlled machine and be prepared to use emergency stop equipment if any malfunction occurs.

## Performance Curves

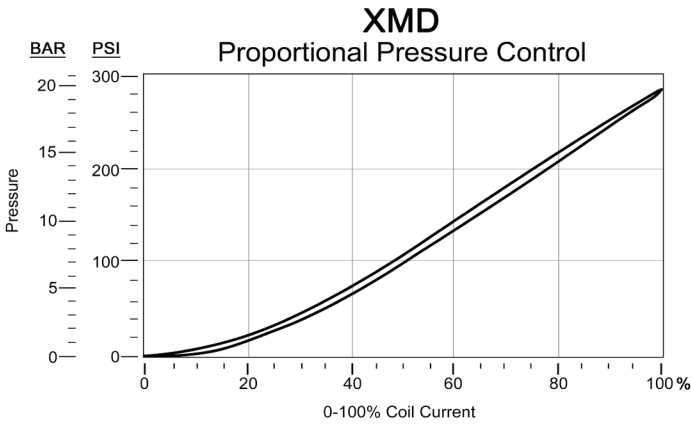

Example showing the PRDL pressure control valve combined with XMD precision.

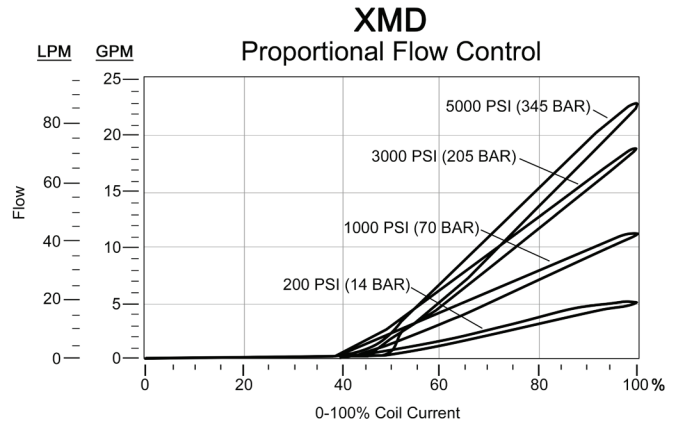

Example showing the FPBF FLeX flow control valve combined with XMD precision.

## XMD-01 Example Configuration: Motor Speed Control

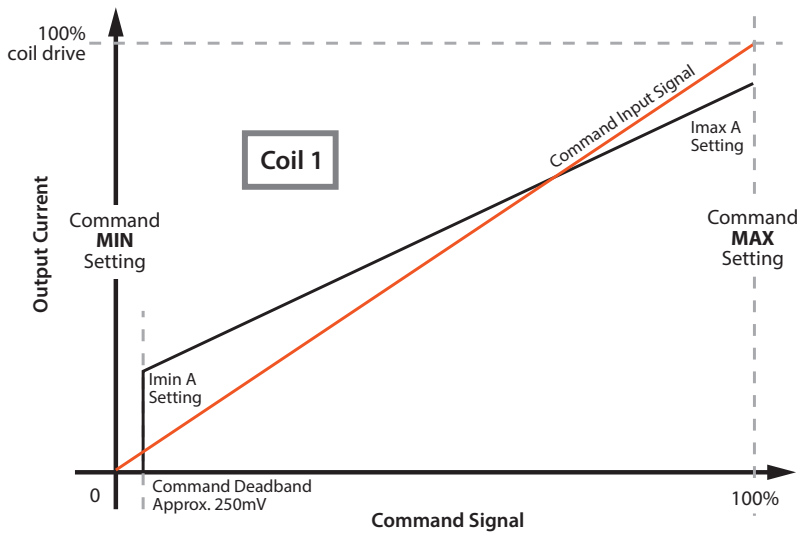

### Single-Coil Configuration

The XMD-01 is designed to control pressure or flow using a single output. This can be translated to control single-direction pumps, motor speed and torque, or single-acting cylinders.

Visit our website to download Sun's ["Electro-Hydraulic Terms and Definitions"](#).

NOTE: For best grounding practices, isolate pin 7, supply ground, from pins 3 and 5, command, +5Vdc reference, and output grounds.

**Warning:** Never use this unit without ensuring ALL work areas are clear of personnel.

\*Hydraulic schematic for reference only.

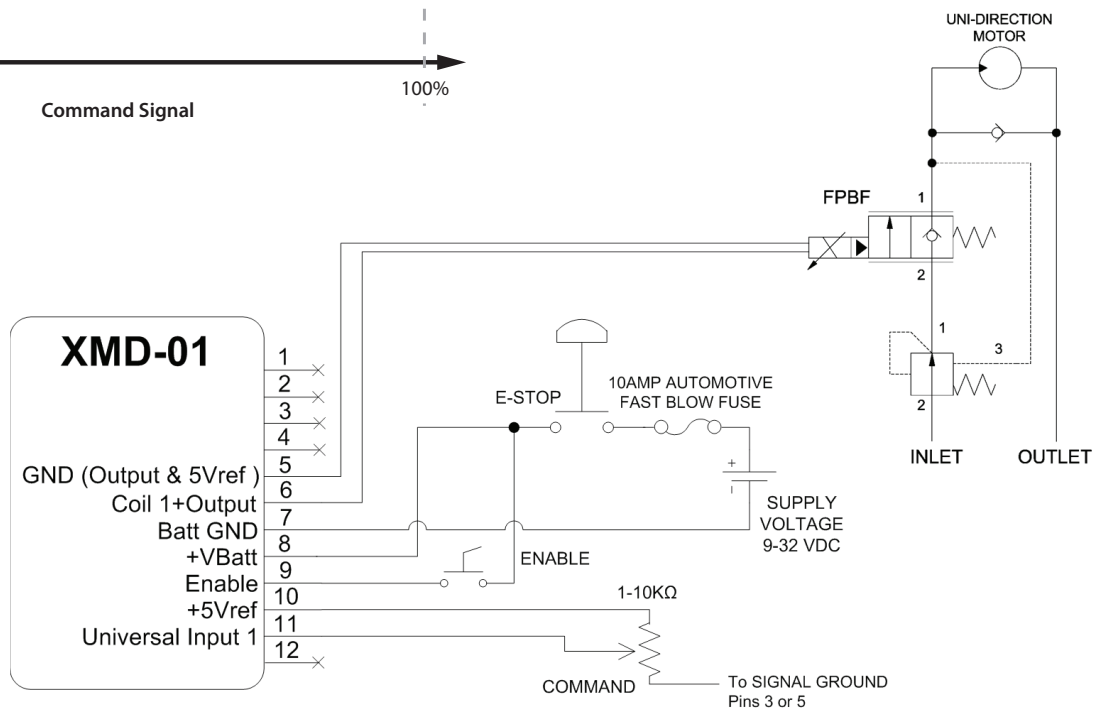



## XMD-02 Example Configuration: Cylinder Direction & Speed Control

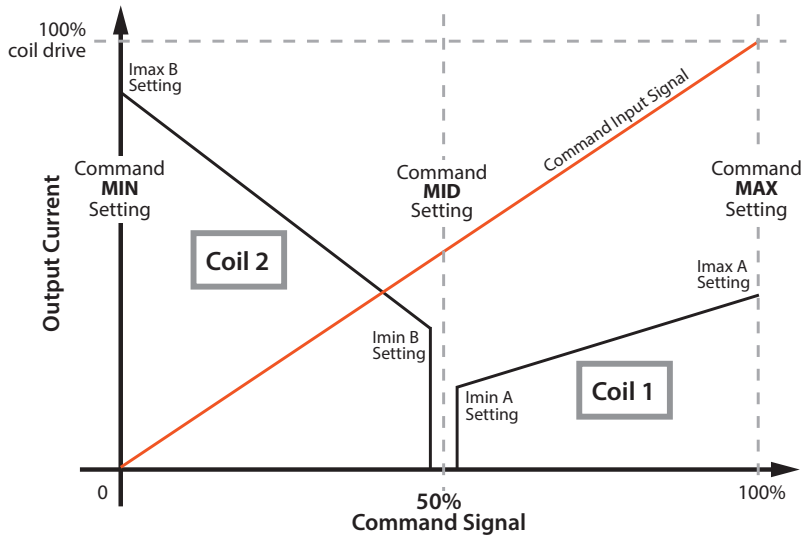

### Dual-Coil Configuration

The XMD-02 is designed to control pressure or flow using two outputs that can be configured for directional or independent use. This can be translated to control bi-directional variable speed pumps, bi-directional motors and bi-directional cylinders.

Visit our website to download Sun's ["Electro-Hydraulic Terms and Definitions"](#).

### XMD Mobile App Configuration

The XMD Mobile App is designed to offer single- and dual-output applications for the XMD-02. Both outputs can be configured to operate independently, simultaneously or inverted for directional control as shown here.

NOTE: For best grounding practices, isolate pin 7, supply ground, from pins 3 and 5, command, +5Vdc reference, and output grounds.



#### Warning:

Never use this unit without ensuring ALL work areas are clear of personnel.

\*Hydraulic schematic for reference only.

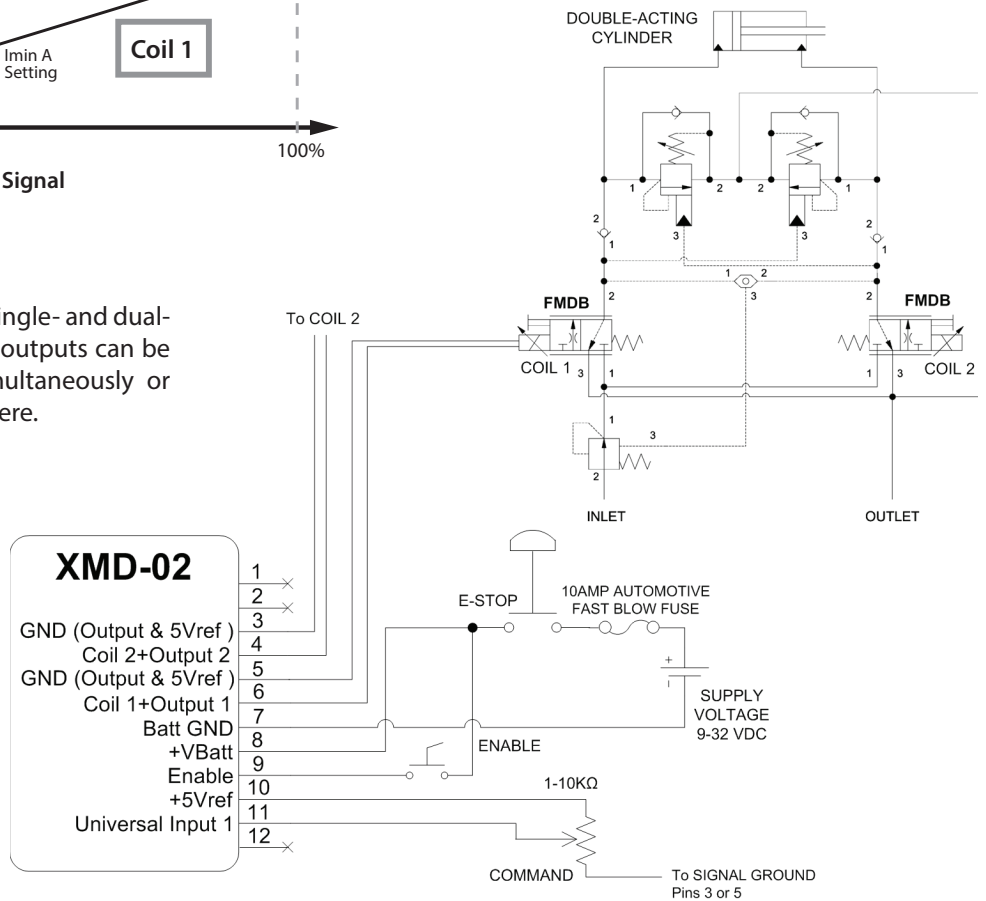

## Connections

The XMD open architecture offers a wide range of connection and coil compatibility. Connections include Deutsch, DIN 43650-A, Amp Junior Timer, twin-lead and metri-pack.





The XMD-01 and XMD-02 ship standard with the remote mount bracket.

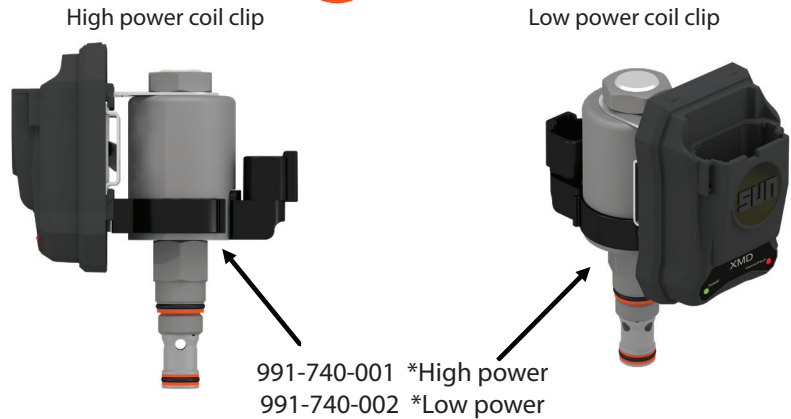

## Accessories

Item	Part Number	Description
1	XMD-01	XMD-01 assembly, includes standard mounting clip
2	XMD-02	XMD-02 assembly, includes standard mounting clip
3	991-711-300	12-pin Deutsch prototype harness, 3M, XMD-01
4	991-712-300	12-pin Deutsch prototype harness, 3M, XMD-02
5	991-713-030	2-pin Deutsch prototype harness, 30cm
6	991-740-001	FLeX high power coil clip assembly
7	991-740-002	FLeX low power coil clip assembly

Additional accessory options are available on Sun's website. Please visit [www.sunhydraulics.com](http://www.sunhydraulics.com) for more details.

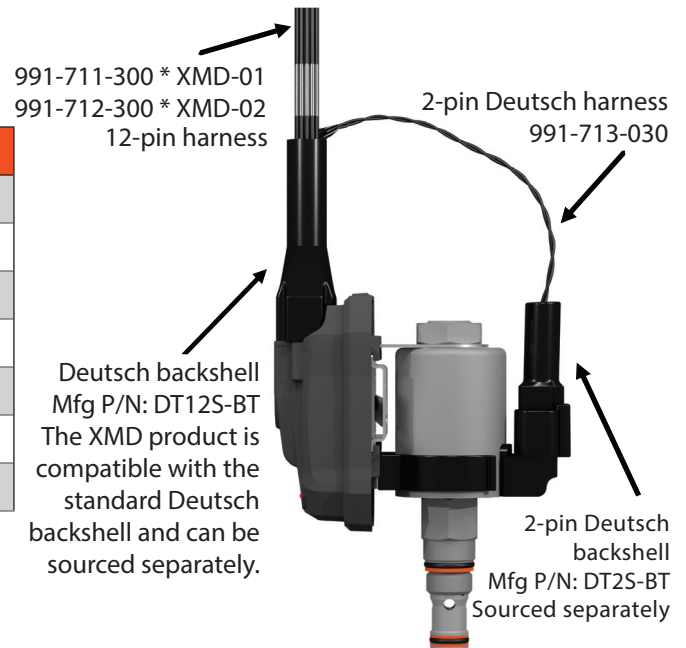

The Bluetooth® word mark and logos are registered trademarks owned by the Bluetooth SIG, Inc. Other trademarks and trade names are those of their respective owners.

Sun Hydraulics Headquarters  
Sarasota, Florida USA  
(1) 941 362 1200  
[suninfo@sunhydraulics.com](mailto:suninfo@sunhydraulics.com)

Sun Hydraulics Limited  
Coventry England  
+44 2476 217 400  
[sales@sunuk.com](mailto:sales@sunuk.com)

Sun Hydraulik GmbH  
Erkelenz Germany  
+49 2431 80910  
[sales@sunhydraulik.de](mailto:sales@sunhydraulik.de)

Sun Hydraulics Corp. (India)  
Bangalore India  
+91 8028 456325  
[sunindiainfo@sunhydraulics.com](mailto:sunindiainfo@sunhydraulics.com)

**ATP HYDRAULIK**  
available at:  
[sales@atphydraulik.ch](mailto:sales@atphydraulik.ch)  
[www.atphydraulik.ch](http://www.atphydraulik.ch)

Sun Hydraulics Korea Corp.  
Incheon Korea  
+82 3281 31350  
[sales@sunhydraulics.co.kr](mailto:sales@sunhydraulics.co.kr)

Sun Hydraulics China Co. Ltd.  
Shanghai P.R. China  
+86 2151 162862  
[sunchinainfo@sunhydraulics.com](mailto:sunchinainfo@sunhydraulics.com)

Sun Hydraulics Corp. (S.America)  
Rosario, Argentina  
+54 9 341 584 3075  
[ventas@sunhydraulics.com](mailto:ventas@sunhydraulics.com)