

SV13-10-O/OP/OS - Solenoid Valve

Poppet type, normally open solenoid valve (free reverse flow)
45 L/min (12 USgpm) • 350 bar (5000 psi)

A

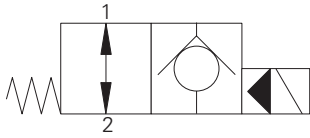

Operation

In the de-energized position the valve allows free flow in both directions.

When the solenoid is energized the pilot poppet closes the orifice and the valve closes blocking flow from port 2 to 1 while allowing free flow from port 1 to 2.

Features

Hardened and ground working parts. Lapped seat for low leakage. IP69K Tough coil compatibility. Continuously rated. Compact design with low pressure drop. 350 bar working pressure.

Sectional View

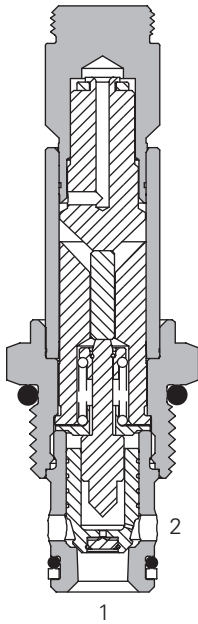

Performance

Ratings and Specifications

Performance data is typical with fluid at 21,8 cSt (105 SUS) and 49° C (120° F)

Typical application pressure (all ports)	350 bar (5000 psi)
Cartridge fatigue pressure (infinite life)	310 bar (4500 psi)
Rated flow	45 L/min (12 USgpm)
Internal leakage	less than 5 drops/min, max @ 350 bar (5000 psi)
Temperature range	-40° to 100°C (-40° to 212°F)
Coil duty	Continuous from 85% to 110% of nominal voltage
Cavity	C-10-2
Fluids	All general purpose hydraulics fluids such as: MIL-H-5606, SAE 10, SAE 20 etc.
Filtration	Cleanliness code 18/16/13
Housing material (standard)	Steel
Weight including coil	0,18 kg (0.39 lbs)
Seal kit	565803 (Buna-N), 566086 (Viton®)

Viton is a registered trademark of E.I. DuPont

Description

This is a 2-way, 2-position, poppet type, high pressure, pilot operated, normally open solenoid valve. This valve is used in applications requiring low leakage, such as load holding applications or as a general purpose diverter or dump valve.

Application Note:

This valve is pilot operated and requires a minimum flow of 1-2 L/min (0.3-0.5 USgpm) in order to shift. For operation at very low flow conditions contact your Eaton representative.

Pressure Drop

Cartridge only

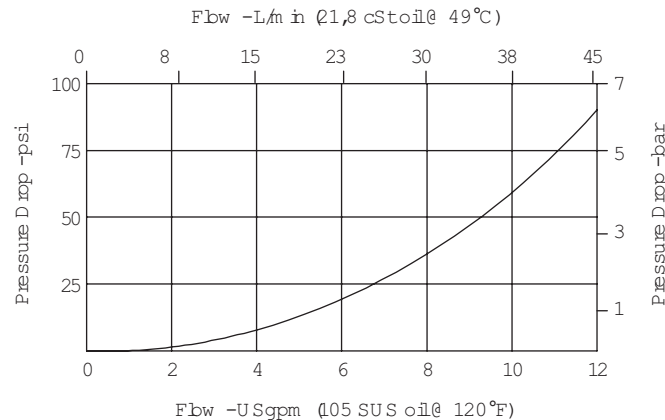

Port 1 to port 2 and port 2 to port 1 de-energized



available at:
ATP Hydraulik AG
Aahusweg 8
CH-6403 Küssnacht am Rigi
www.atphydraulik.com

Where measurements are critical request certified drawings. We reserve the right to change specifications without notice.

SV13-10-O/OP/OS - Solenoid Valve

Poppet type, normally open solenoid valve (free reverse flow)
45 L/min (12 USgpm) • 350 bar (5000 psi)

Model Code

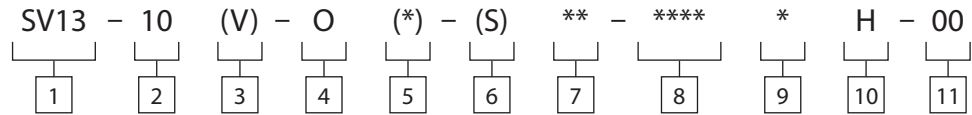

1 Function
SV13 - Solenoid valve

2 Size
10 - 10 size

3 Seal Material
Blank - Buna-N
V - Viton™

4 Style
O - Normally open

5 Manual Override Option
Blank - No manual override
P - Push type
S - Screw type
For valve dimensions with manual override option installed see page A-980.

6 Valve Housing Material

7 Port Size

Code	Port Size	Housing Number
0	Cartridge only	
2G	1/4" BSPP	02-075102
3G	3/8" BSPP	02-075103
6T	SAE 6	02-075100
8T	SAE 8	02-075101

See section J for housing details.

8 Voltage Rating

00 - No coil
12D - 12VDC
24D - 24VDC
36D - 36VDC
24A - 24VAC
115A - 115VAC
230A - 230VAC
12B - 12VDC/w diode*
24B - 24VDC/w diode*
*Optional arc suppression diode.

9 Connector Types

Blank - No coil
G - ISO 4400 DIN 43650
Q - Spade terminals
W - Flying lead
N - Deutsch (DC only)
Y - Amp JR (DC only)
D - Metripack 150 male (DC only)
J - Metripack 280 male (DC only)

10 Coil Series
H - 10 series, 29W
For coil part numbers and dimensions see section C.

11 Special Features
00 - None
(Only required if valve has special features, omitted if "00".)

Dimensions

mm (inch)

Cartridge Only

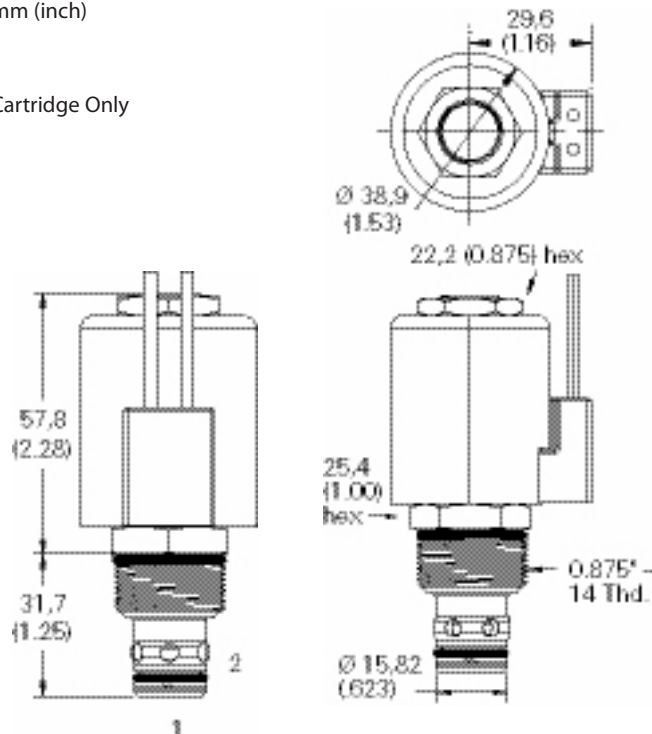

Torque cartridge in aluminum housing 68-75 Nm (50-55 ft lbs)

Note: When solenoid valve is ordered as cartridge only, nut is included.

Installation Drawing

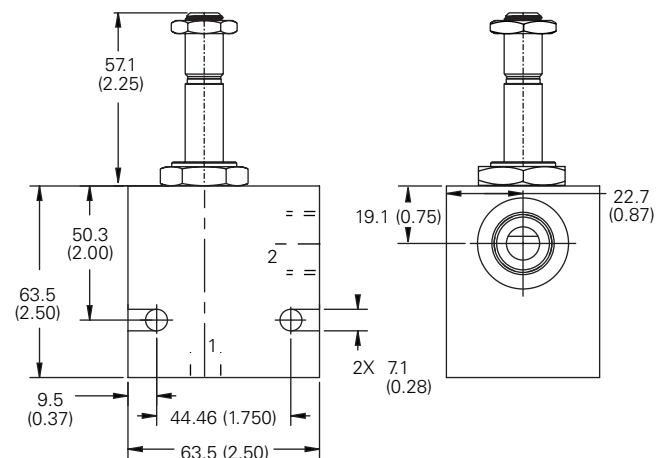

WARNING
Maintain 5-8 Nm (4-6 ft lbs) maximum torque on valve tube nut. Over tightening may cause valve failure.