

Technical Information

Low Speed, High Torque Hydraulic Motors

Xcel XLH, XLS, XL2, XL4 and XL6

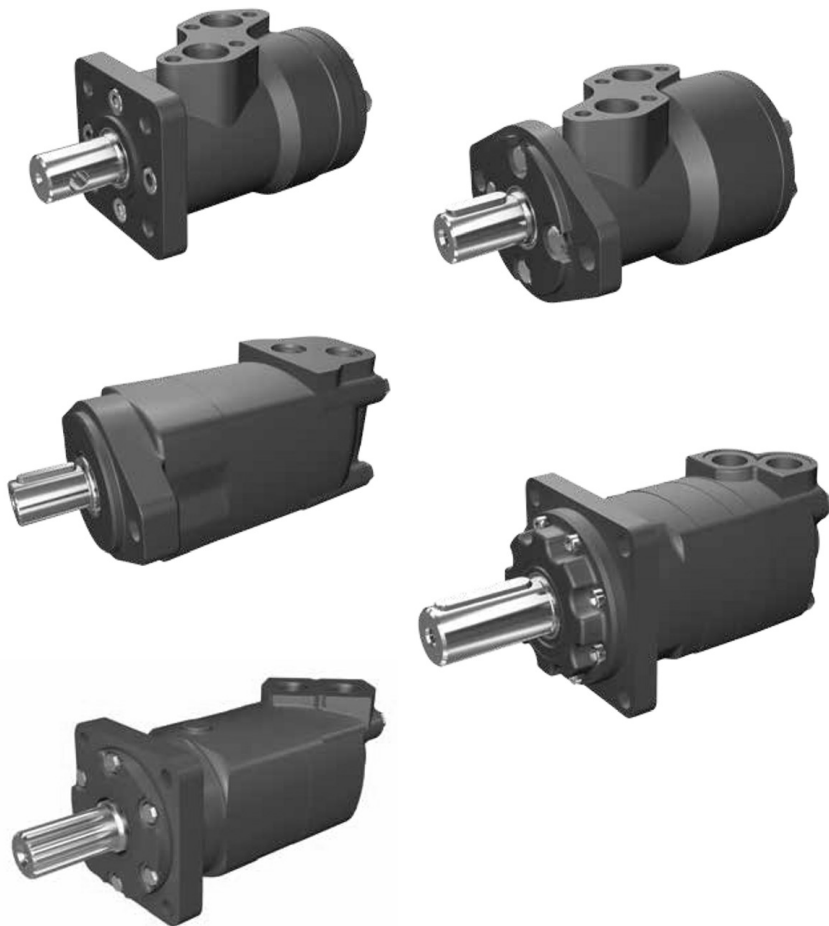

Revision history

Table of revisions

Date	Changed	Rev
March 2025	Updated for global launch	0301
November 2023	Quality updates and added new options for shaft and shaft seal	0201
October 2023	First edition	0101

Contents

XLH and XLS spool valve motor series

About the Xcel XLH and XLS.....	5
Features, benefits, and applications.....	5
Specifications overview.....	6
XLH series.....	6
Part identification.....	6
Technical data.....	7
Product numbers.....	9
Performance data.....	10
Dimensions.....	16
Model code.....	17
XLS series.....	20
Part identification.....	20
Technical data.....	20
Product numbers.....	22
Performance data.....	23
Dimensions.....	28
Model code.....	29
Mounting dimensions.....	31
Shaft dimensions.....	33
Ports.....	36
Side load capacity.....	37
Case pressure seal limitation.....	39
Shaft seal performance graphs.....	40

XL2 disc valve motor series

About the XL2 series motors.....	41
Features, benefits, and applications.....	41
Specifications overview.....	42
Part identification.....	43
Technical data.....	43
Product numbers.....	45
Performance data.....	46
Standard and wheel mount dimensions.....	51
Bearingless dimensions.....	54
Bearingless motor installation information.....	60
Bearingless motor EMEA (AZ) installation information.....	62
Mounting dimensions.....	64
Shaft dimensions.....	66
Port dimensions.....	70
Shaft side load capacity.....	75
Case pressure seal limitation.....	76
Model code.....	77

XL4 disc valve motor series

About the XL4 series.....	81
Features, benefits, applications.....	81
Specifications overview.....	82
Part identification.....	83
Technical data.....	83
Performance data.....	85
Mounting dimensions.....	88
Bearingless mount dimensions.....	90
Bearingless motor installation information.....	91
Shaft dimensions.....	93
Ports dimensions.....	95
Shaft side load capacity.....	96
Pressure seal limitation.....	98
Model code.....	99

XL6 disc valve motor series

Contents

About the XL6 series.....	102
Features, benefits, applications.....	102
Specifications overview.....	103
Part identification.....	104
Technical data.....	104
Performance data.....	106
Mounting dimensions.....	110
Bearingless mount dimensions.....	113
Bearingless installation information.....	115
Shaft dimensions.....	117
Ports dimensions.....	119
Side load capacity.....	120
Case pressure seal limitation.....	122
Model code.....	123

XLH and XLS spool valve motor series

About the Xcel XLH and XLS

The Danfoss Xcel™ series low speed, high torque spool valve motors offer the most popular features and are optimized to bring the highest value in medium duty applications.

Xcel spool valve motors distribute pressurized fluid into and out of the orbit gear set via valve slots integrated into the output shaft. The spool valve motors incorporate both valving and hydrodynamic journal bearings into a common shaft design. These motors incorporate the proven orbit motor principle to provide high torque at low speeds. Motor shaft rotation can be instantly reversed by changing direction of input/output flow while generating equal torque in either direction. The displacements available provide a wide variety of speeds and torque.

The XLS motor feature Danfoss' Geroler™ technology to minimize friction and increase operating efficiency, while internal check valves limit case pressure to that of the outlet port.

XLH and XLS features, benefits, and applications

Features

- Proven orbit motor principle
- Hydrodynamic journal bearings
- Three moving components (Gerotor-star, drive, and shaft)
- Three –zone pressure design
- Optimized drive running angle
- Variety of displacements and shafts
- Designed for medium and low duty

Benefits

- Compact, powerful package
- High efficiency
- Design flexibility
- Economically tailored solutions
- Long bearing life (at rated loads)

Applications

- Aerial work platform
- Augers
- Conveyors
- Food processing
- Harvesters
- Machine tools
- Spreaders
- Turf care equipment
- Winches

XLH and XLS spool valve motor series

XLH and XLS specifications overview

XLH motor specifications

Parameter	Data
Gerotor element	11 displacements
Flow l/min [US gal/min]	57 [15] continuous 68 [18] intermittent
Speed	Up to 800 rpm
Δ Pressure bar [psi]	124 [1800] continuous 138 [2000] intermittent
Torque N-m [in·lbs]	426 [3770] continuous 507 [4485] intermittent

XLS motor specifications

Parameter	Data
Gerotor element	9 displacements
Flow l/min [US gal/min]	61 [16.1] continuous 75 [19.8] intermittent
Speed	Up to 1193 rpm
Δ Pressure bar [psi]	175 [2538] continuous 207 [3002] intermittent
Torque N-m [in·lbs]	410 [3629] continuous 503 [4452] intermittent

Continuous motor may run continuously at the listed ratings

Intermittent 10% of every minute

XLH series

XLH part identification

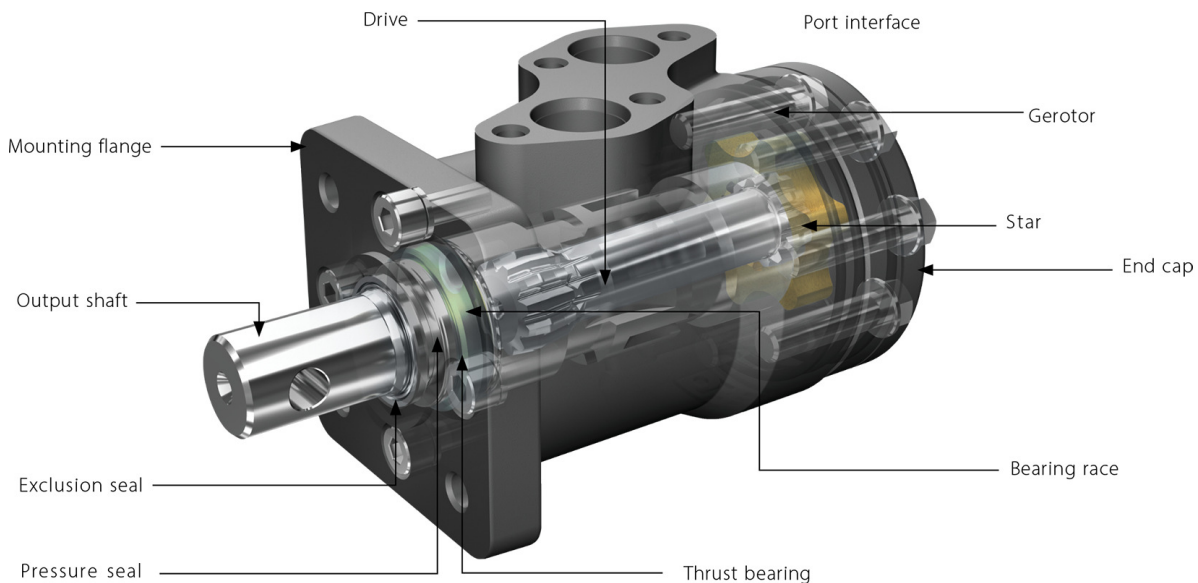

XLH and XLS spool valve motor series

XLH technical data

XLH 50cc-160cc technical data

Displacement cm ³ /r [in ³ /r]		53 [3.2]	63 [3.8]	80 [4.9]	100 [6.2]	125 [7.6]	160 [9.6]
Flow l/min [US gal/min]	Continuous	38 [10]	45 [12]	57 [15]	57 [15]	57 [15]	57 [15]
	Intermittent	45 [12]	53 [14]	68 [18]	68 [18]	68 [18]	68 [18]
Max speed rpm	Continuous	721	693	710	568	462	354
	Intermittent	864	806	848	678	551	421
Pressure Δ bar [psi]	Continuous	124 [1800]	124 [1800]	124 [1800]	124 [1800]	124 [1800]	115 [1650]
	Intermittent	138 [2000]	138 [2000]	138 [2000]	138 [2000]	138 [2000]	124 [1800]
Torque* N·m [in·lbs]	Continuous	83 [735]	104 [920]	130 [1150]	162 [1430]	200 [1770]	242 [2140]
	Intermittent	93 [825]	116 [1025]	145 [1285]	181 [1600]	223 [1975]	260 [2300]
Weight kg [lbs]		5 [11.0]	5.3 [11.6]	5.5 [12.1]	6.1 [13.4]	6.2 [13.6]	6.4 [14.1]

* See shaft torque ratings for limitations.

XLH 200cc-485cc technical data

Displacement cm ³ /r [in ³ /r]		200 [12.2]	245 [14.9]	315 [19.2]	390 [23.8]	485 [30.0]
Flow l/min [US gal/min]	Continuous	57 [15]	57 [15]	57 [15]	57 [15]	57 [15]
	Intermittent	68 [18]	68 [18]	68 [18]	68 [18]	68 [18]
Max speed rpm	Continuous	286	234	174	144	114
	Intermittent	341	282	209	171	138
Pressure Δ bar [psi]	Continuous	110 [1600]	100 [1450]	90 [1300]	83 [1200]	69 [1000]
	Intermittent	124 [1800]	124 [1800]	124 [1800]	110 [1600]	90 [1300]
Torque* N·m [in·lbs]	Continuous	287 [2540]	318 [2815]	377 [3340]	419 [3705]	426 [3770]
	Intermittent	324 [2870]	391 [3460]	508 [4495]	547 [4495]	507 [4485]
Weight kg [lbs]		6.7 [14.7]	7.1 [15.6]	7.4 [16.3]	7.7 [16.9]	8 [17.6]

* See shaft torque ratings for limitations.

Δ bar [psi] The true pressure difference between inlet port and outlet port.

Continuous rating Motor may be run continuously at these ratings.

Intermittent operation 10% of every minute.

For maximum case pressure, see the case pressure seal limitation graph.

A simultaneous maximum torque and maximum speed is not recommended. To ensure best motor life, run motor for approximately 1 hour at 30% of rated pressure before application to full load. Be sure motor is filled with fluid prior to any load applications.

XLH and XLS spool valve motor series

Recommended operating parameters

Data	Recommended
Max. inlet pressure	150 bar [2175 psi]  Caution <hr/> <u>Do not exceed Δ pressure rating</u>
Fluids	Premium quality, anti-wear type hydraulic oil with a viscosity of no less than 20-32 cSt at operating temperature.
Operating temperature	82 °C [180 °F]
Filtration	Per ISO cleanliness code 4406:20/18/13

XLH and XLS spool valve motor series

XLH product numbers

Design specifications

Flange	Sideport offset 2-hole oval mounting flange - A2 flange	
Specification	Ref. A1	Ref. A2
Flange pilot diameter	Ø 82.5 mm [3.25 in]	
Flange bolt diameter	Ø 106.4 mm [4.20 in]	
Shaft	Cyl. Ø25 mm (10)	6B splined 1 in (07)
Main port	G 1/2	G 1/2
Drain port	G 1/4	G 1/4
Check valve	No	No
Shaft seal	High pressure shaft seal	
Paint	Painted black	

Product numbers

Displacement	Ref. A1	Ref. A2
50cc	016-0543-003	016-0531-003
63cc	016-0544-003	016-0532-003
80cc	016-0545-003	016-0533-003
100cc	016-0546-003	016-0534-003
125cc	016-0547-003	016-0535-003
160cc	016-0548-003	016-0536-003
200cc	016-0549-003	016-0537-003
245cc	016-0550-003	016-0538-003
315cc	016-0551-003	016-0539-003
390cc	016-0552-003	016-0540-003
485cc	016-0553-003	016-0541-003

XLH and XLS spool valve motor series

XLH series performance data

Performance data is typical at 25 cSt (12 SUS). Actual data may vary slightly from unit to unit in production.

XLH motor 053cc

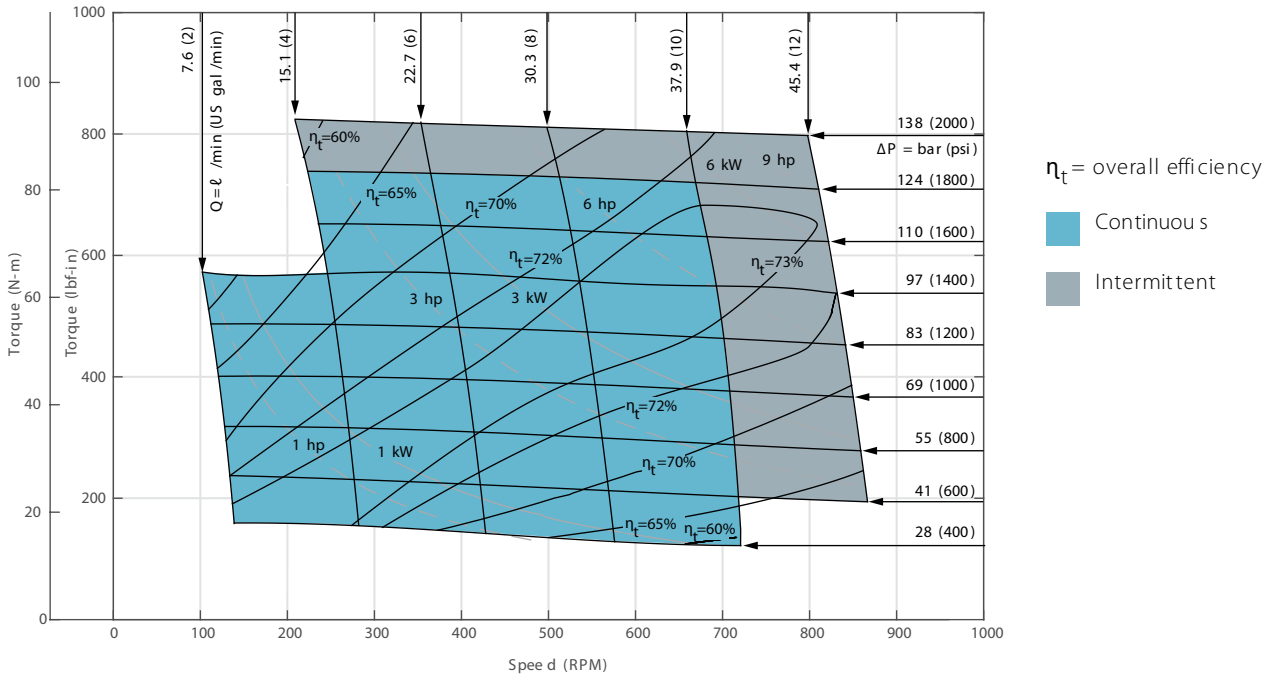

XLH motor 063cc

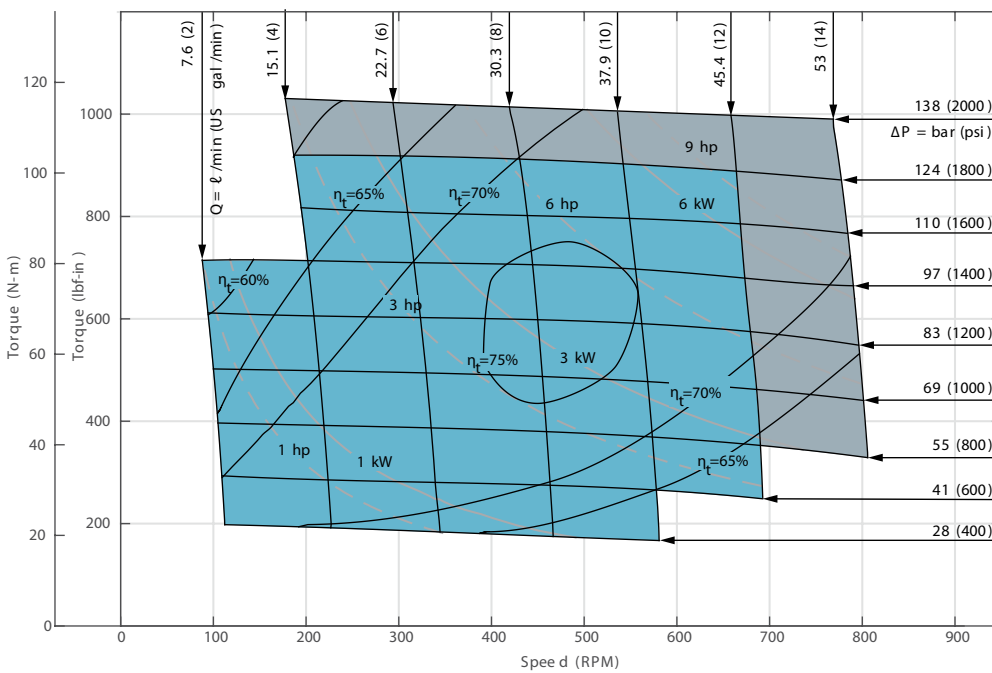

XLH and XLS spool valve motor series

XLH motor 080cc

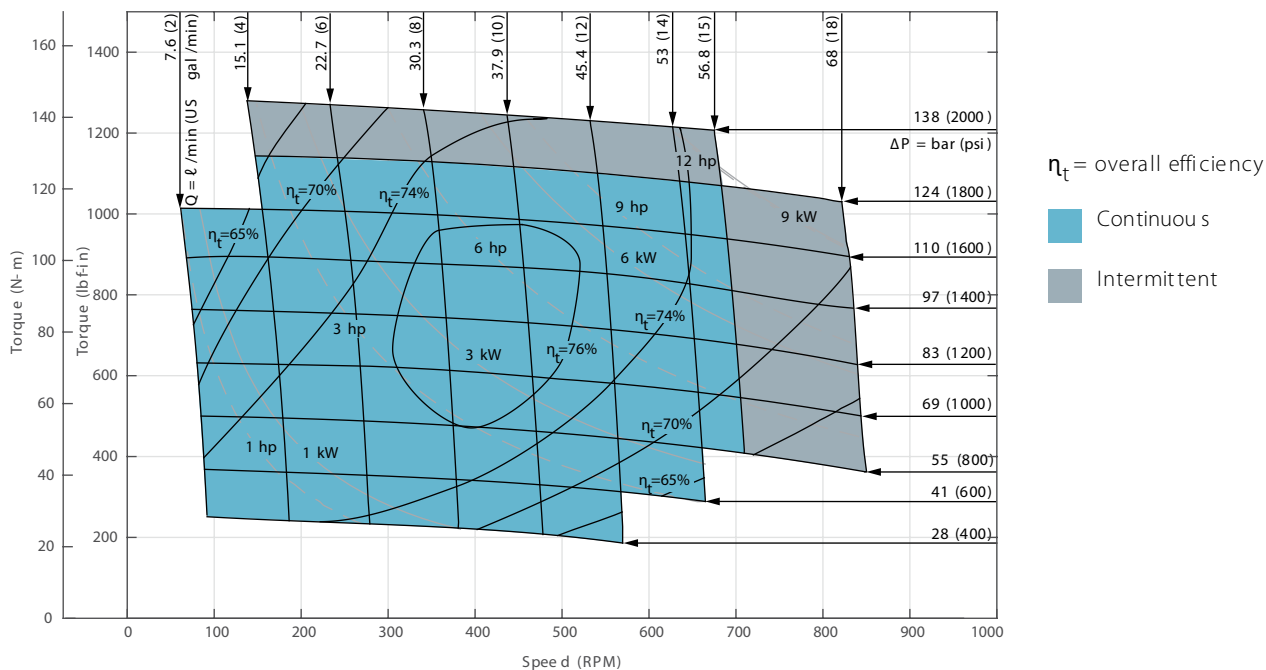

XLH motor 100cc

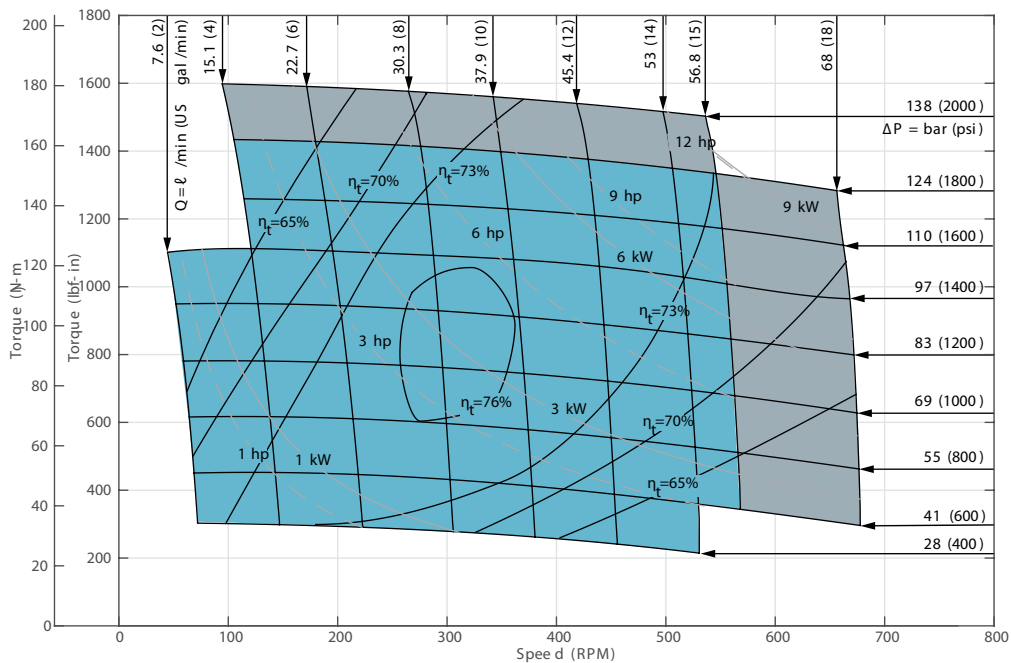

XLH and XLS spool valve motor series

XLH motor 125cc

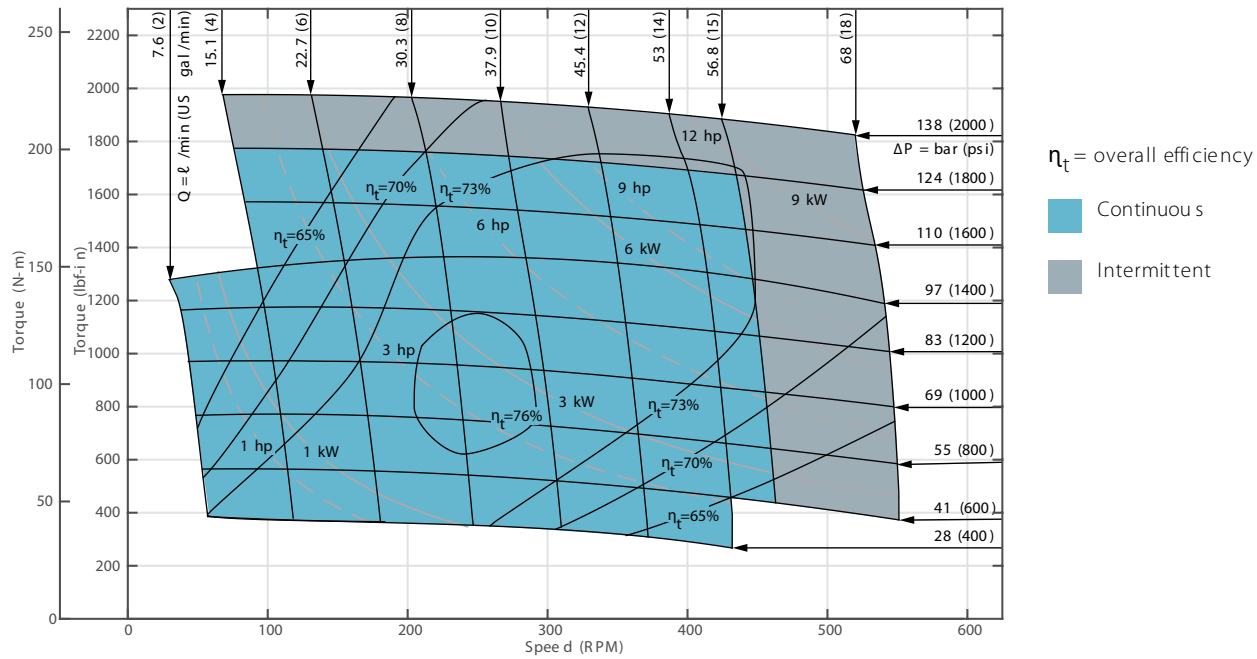

XLH motor 160cc

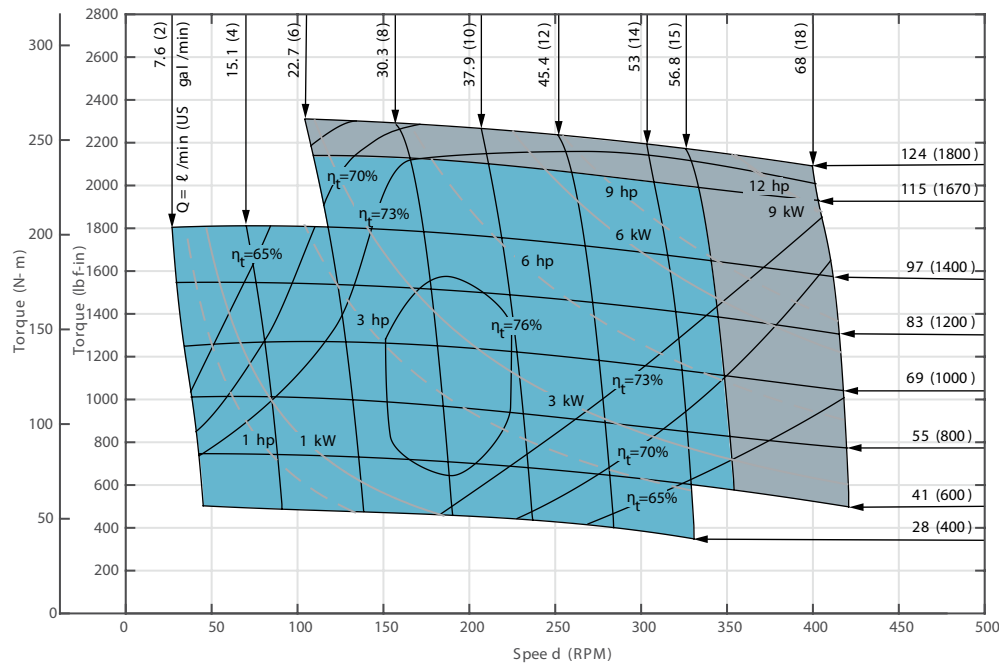

XLH and XLS spool valve motor series

XLH motor 200cc

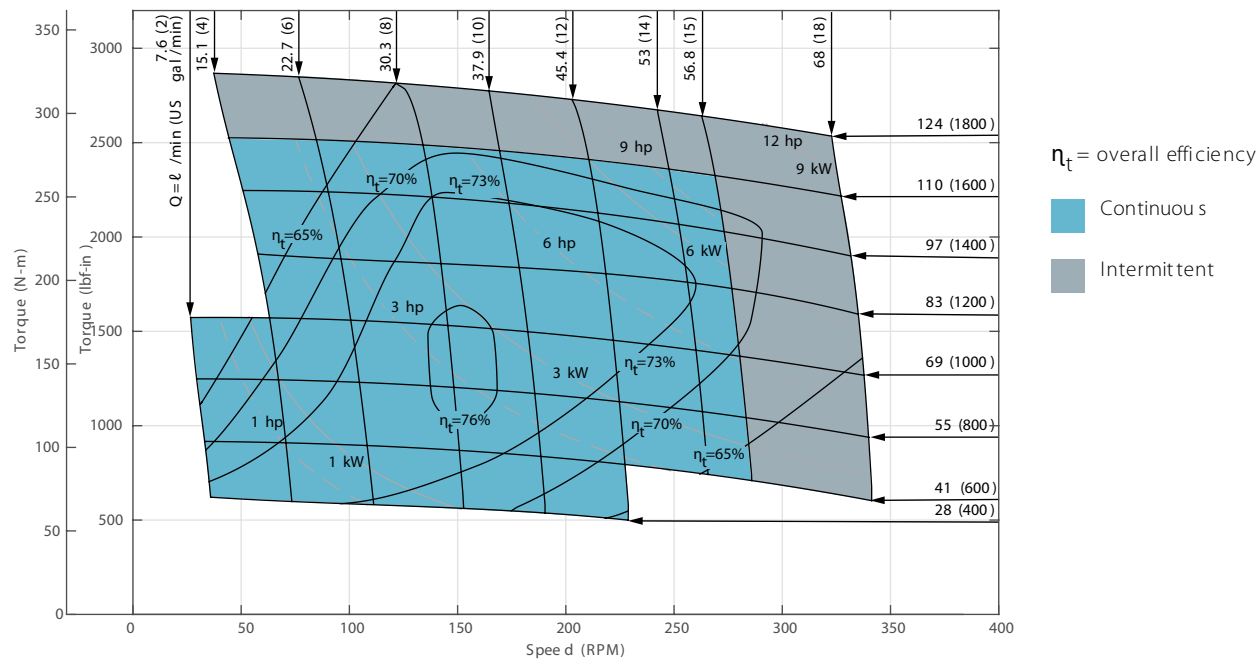

XLH motor 245cc

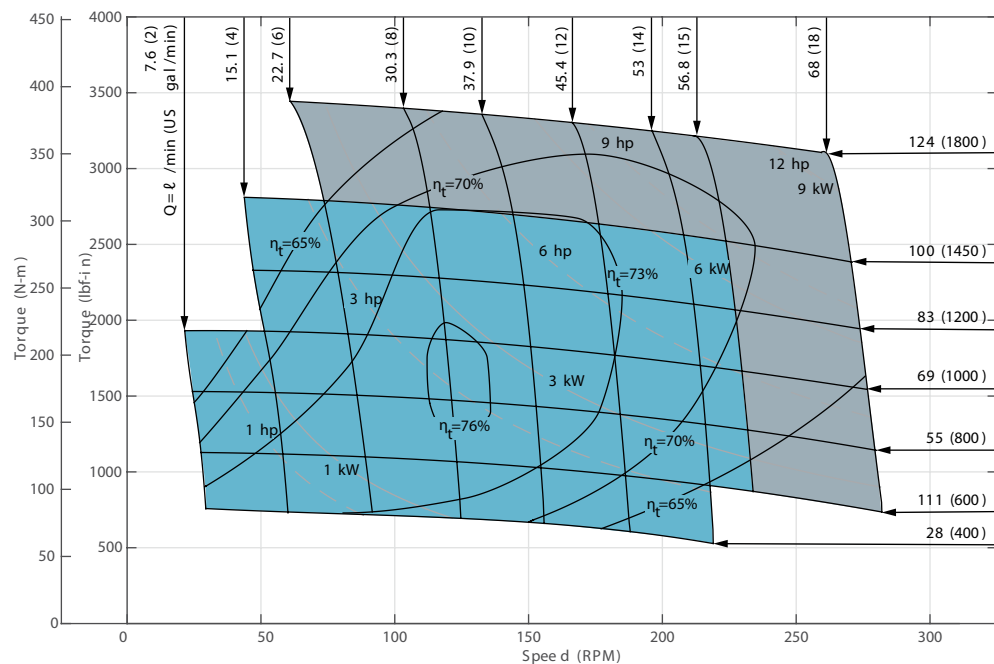

XLH and XLS pool valve motor series

XLH motor 315cc

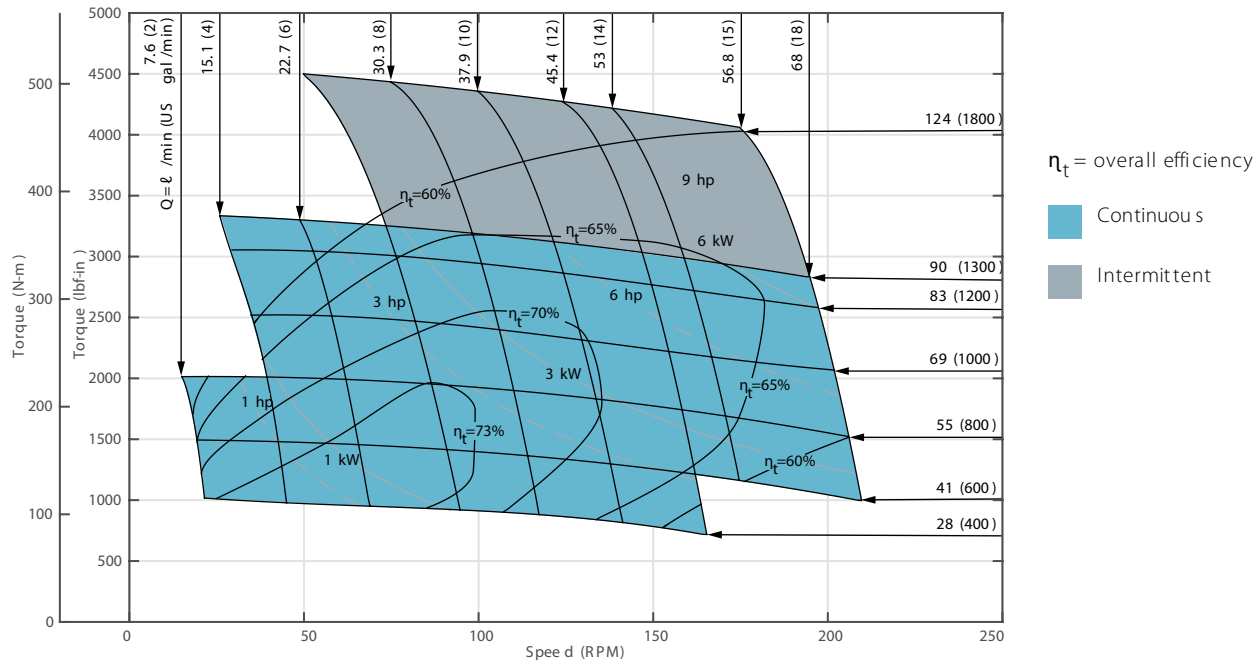

XLH motor 390cc

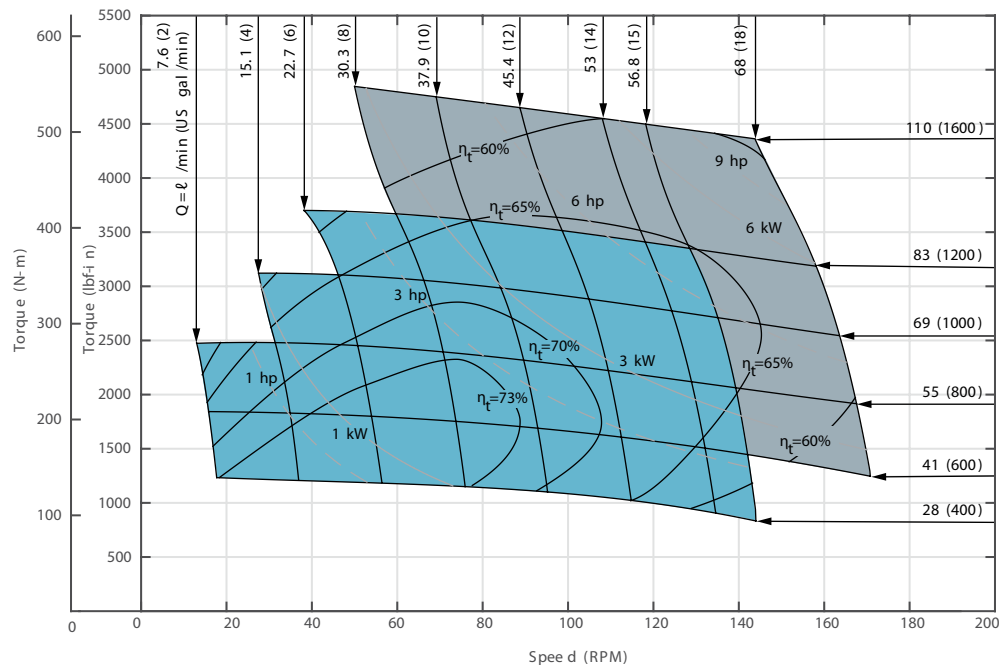

XLH and XLS spool valve motor series

XLH motor 485cc

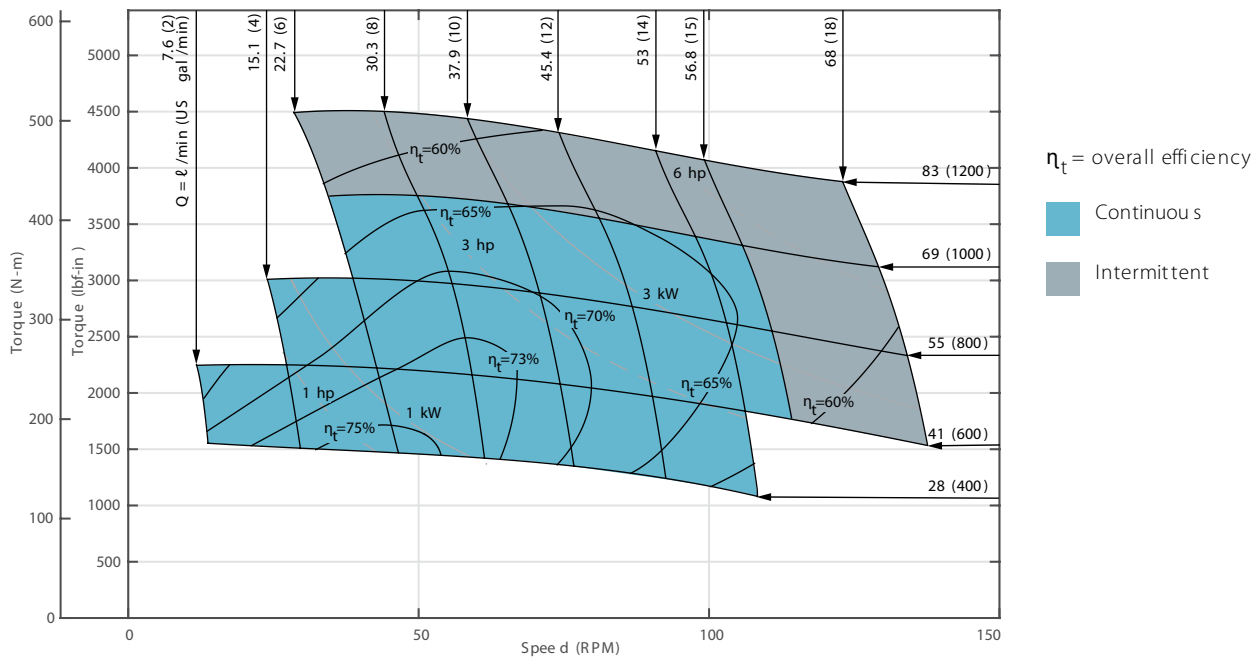

XLH and XLS spool valve motor series

XLH dimensions

Standard rotation viewed from shaft end

- Port A pressurized – CW
- Port B pressurized – CCW
- XLH standard shaft seal and section seal kit number: Z331-23
- XLH high pressure shaft seal and section seal kit number: Z331-41

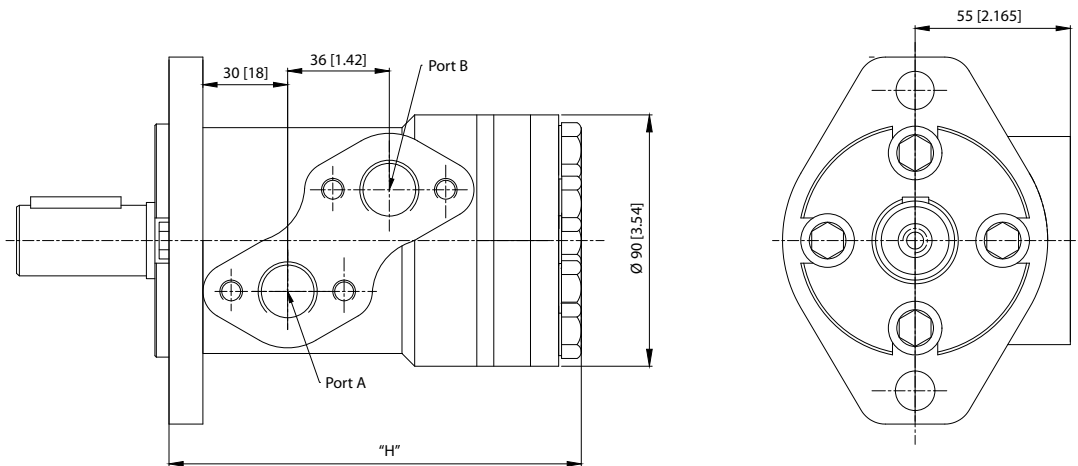

Dimension "H"

Displacement cm ³ /r [in ³ /r]	"H" mm [in]
53 [3.1]	144 [5.67]
63 [3.8]	146 [5.74]
80 [4.9]	148 [5.82]
100 [6.2]	150 [5.91]
125 [7.6]	153 [6.02]
160 [9.6]	158 [6.22]
200 [12.2]	163 [6.42]
245 [14.9]	169 [6.65]
315 [19.2]	179 [7.05]
390 [23.8]	189 [7.44]
485 [30.0]	201 [7.91]

Data is based on mounting flange SAE A.

XLH and XLS spool valve motor series

XLH model code

The reference number in the model code corresponds with the product components.

Model code identification

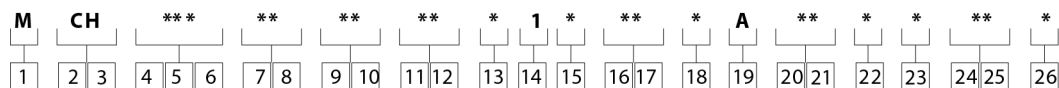

XLH product, series, displacement options

1 - product

Code	Description
M	Motor

2, 3 - series

Code	Description
CH	XLH series

3, 4, 5 - displacement cm^3/r [in^3/r]

Code	Description
053	53 [3.2]
063	63 [3.8]
080	80 [4.9]
100	100 [6.2]
125	125 [7.6]
160	160 [9.6]
200	200 [12.2]
245	245 [14.9]
315	315 [19.2]
390	390 [23.8]
485	485 [30.0]

XLH mounting flange and output shaft options

7, 8 - mounting flange

Code	Description
AA	2 bolt standard, SAE A, 82.55 x 5 pilot, pilot 2-13.5 dia. mounting holes on 106.4 dia.
AC	2 bolt standard, 82.55 x 2.8 pilot, 2-13.5 dia. mounting holes on 106.4 dia.
AD	4 bolt standard, 44.40 dia. x 3.05 pilot, 375-16 UNC-2B, mounting holes on 82.55 dia. B.C.
AE	4 bolt standard, 44.40 dia. x 3.05 pilot, M10x1 .5-6H mounting holes on 82.55 dia. B.C.

XLH and XLS spool valve motor series

9, 10 - output shaft

Code	Description
01	25 dia. straight, parallel key A8 x 7 x 32, M8 hole in shaft end, DIN 6885
02	25 dia. straight, 5mm extra length parallel key A8 x 7 x 32, M8 hole in shaft end, DIN 6885
03	25.4 dia. straight, parallel key ¼ x ¼ x 1¼, M8 hole in shaft end, BS46
04	25.4 dia. splined shaft, SAE 6B, .250-20 UNC-2B hole in the shaft end
05	25.4 dia. straight, parallel key, .250-20 UNC 2B hole in the shaft end
07*	25.4 dia. splined shaft, SAE 6B, M8 X 1.25-6H thread in shaft end Extended length (54 mm from flange)
08	25.4 dia. straight, 10.3 [.405] dia. cross hole 15.7 [.618] from .250-20 UNC-2B hole in the shaft end
10*	25 dia. straight, 5mm extra length parallel key A8 x 7 x 32, M8 thread in shaft end. Extended length (54 mm from flange)

* Only available for design code C

Main ports, case drain, gerotor options

11, 12 - main ports

Code	Description
AA	Staggered port 2-G1/2 ISO228/1 Manifold ports (4 x M8 mounting holes)
AE	Staggered port 2-0.875-14 UNF-2B O-ring or manifold ports (4-M 8-6H mounting holes)

13 - case drain

Code	Description
0	None
1	G1/4 ISO228/1
3	0.4375-20 UNF-2B

14 - gerotor

Code	Description
1	Standard gerotor

Shaft, seal, speed sensor, manifold options

15 - shaft

Code	Description
0	Standard shaft

XLH and XLS spool valve motor series

16, 17 - shaft seal

Code	Description
00	Standard seals
01	Seal guard
02	High pressure shaft seal

18 - speed sensor

Code	Description
0	None

19 - manifold block

Code	Description
A	None

Special features, assembly, identification options

20, 21 - special features

Code	Description
00	None

22 - special assembly instructions

Code	Description
0	None
1	Reverse rotation

23 - paint

Code	Description
C	Black primer

24, 25 - customer identification or nameplate

Code	Description
00	None

26 - design code

Code	Description
B	Second
C	Third

XLH and XLS spool valve motor series

XLS series

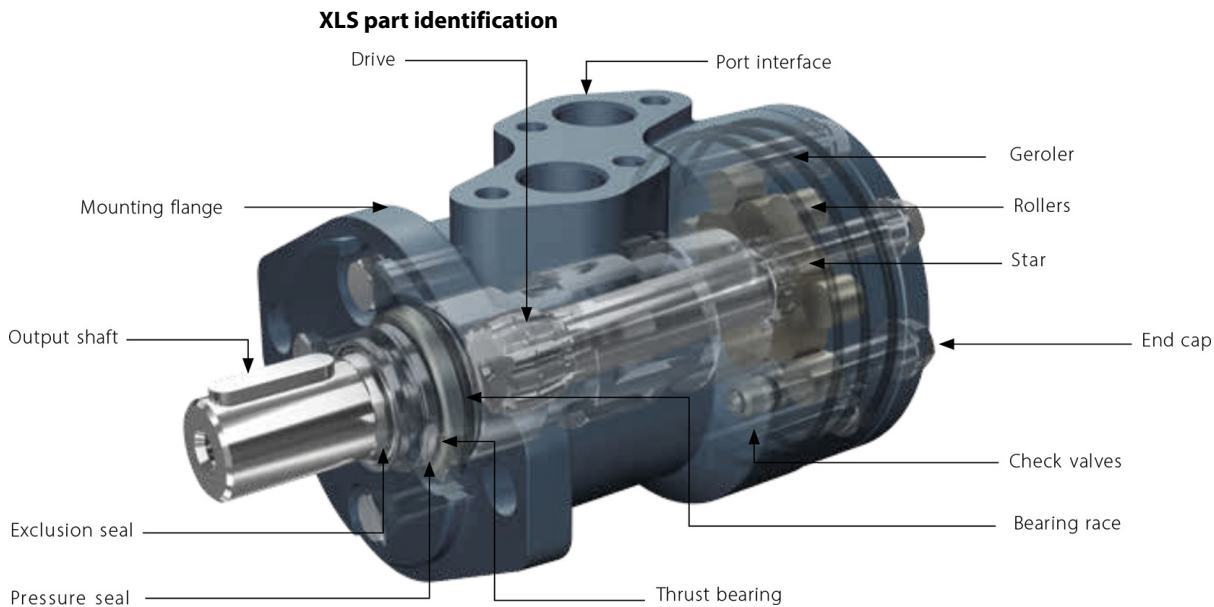

The XLS series features the same basic construction and layout as the XLH series. XLS uses geroler technology to further reduce friction and increase volumetric efficiency. XLS also has check valves as standard that drain the case chamber to the motor outlet port. In many applications, this feature enables the case drain to be omitted.

XLS series technical data

XLS 50cc-160cc technical data

Displacement cm³/r [in³]/r		50 [3.1]	80 [4.9]	100 [6.2]	130 [8.0]	160 [9.6]
Flow l/min [US gal/min]	Continuous	53 [14.0]	61 [16.1]	61 [16.1]	61 [16.1]	61 [16.1]
	Intermittent	61 [16.1]	75 [19.8]	75 [19.8]	75 [19.8]	75 [19.8]
Max speed rpm	Continuous	1037	757	600	467	386
	Intermittent	1193	931	738	574	474
Pressure Δ bar [psi]	Continuous	175 [2538]	175 [2538]	175 [2538]	175 [2538]	175 [2538]
	Intermittent	207 [3002]	207 [3002]	207 [3002]	207 [3002]	207 [3002]
Torque* N·m [in·lbs]	Continuous	127 [1124]	202 [1788]	248 [2195]	320 [2832]	380 [3363]
	Intermittent	150 [1328]	240 [2124]	290 [2567]	374 [3310]	454 [4018]
Max output kW [hp]	Continuous	13.8 [18.6]	16.0 [21.7]	15.6 [21.0]	15.7 [21.2]	15.4 [20.9]
	Intermittent	18.7 [25.4]	23.4 [34.5]	22.4 [30.4]	22.5 [30.6]	22.6 [30.7]
Weight kg [lbs]		6.3 [13.8]	7.0 [15.4]	7.5 [16.5]	7.7 [16.9]	7.1 [15.6]

* See shaft torque ratings for limitations.

XLS 195cc-395cc technical data

Displacement cm³/r [in³]/r		195 [11.9]	245 [14.9]	305 [18.7]	395 [24.0]
Flow l/min [US gal/min]	Continuous	61 [16.1]	61 [16.1]	61 [16.1]	61 [16.1]
	Intermittent	75 [19.8]	75 [19.8]	75 [19.8]	75 [19.8]

XLH and XLS spool valve motor series

XLS 195cc-395cc technical data (continued)

Displacement cm ³ /r [in ³]/r		195 [11.9]	245 [14.9]	305 [18.7]	395 [24.0]
Max speed rpm	Continuous	313	250	199	155
	Intermittent	385	307	245	190
Pressure Δ bar [psi]	Continuous	144 [2089]	120 [1740]	97 [1407]	78 [1131]
	Intermittent	175 [2538]	150 [2176]	120 [1740]	90 [1305]
Torque* N·m [in·lbs]	Continuous	387 [3425]	410 [3629]	405 [3585]	410 [3629]
	Intermittent	465 [4116]	503 [4452]	490 [4337]	483 [4275]
Max output kW [hp]	Continuous	12.7 [17.2]	10.7 [14.5]	8.4 [11.4]	6.7 [9.1]
	Intermittent	18.7 [25.4]	16.2 [22.0]	12.6 [17.1]	9.6 [13.1]
Weight kg [lbs]		8.0 [17.6]	8.4 [18.5]	9.4 [20.6]	9.6 [21.1]

* See shaft torque ratings for limitations.

Δ bar [psi]	The true pressure difference between inlet port and outlet port.
Continuous rating	Motor may be run continuously at these ratings.
Intermittent operation	10% of every minute.

For maximum case pressure, see the case pressure seal limitation graph.

A simultaneous maximum torque and maximum speed is not recommended. To ensure best motor life, run motor for approximately 1 hour at 30% of rated pressure before application to full load. Be sure motor is filled with fluid prior to any load applications.

Recommended operating parameters

Data	Recommended
Max. inlet pressure	225 bar [3263 psi] Caution Do not exceed Δ pressure rating
Fluids	Premium quality, anti-wear type hydraulic oil with a viscosity of no less than 20-32 cSt at operating temperature.
Operating temperature	82 °C [180 °F]
Filtration	Per ISO cleanliness code 4406:20/18/13

XLH and XLS spool valve motor series

XLS product numbers

Design specifications

Flange	Sideport offset 2-hole oval mounting flange - A2 flange (AA)			
	Ref. A1	Ref. A2	Ref. A3	Ref. A4
Flange pilot diameter	Ø 82.5 mm [3.25 in]			
Flange bolt circle diameter	Ø 106.4 mm [4.20 in]			
Shaft	Cyl. Ø 25 mm (10)	6B splined 1 in (Ø7)	Cyl. Ø 25 mm (10)	6B splined 1 in (Ø7)
Main port	G 1/2	G 1/2	G 1/2	G 1/2
Drain port	G 1/4	G 1/4	G 1/4	G 1/4
Check valve	Yes	Yes	Yes	Yes
Shaft seal	High pressure shaft seal		Standard pressure shaft seal	
Paint	Painted black			

Product numbers

Displacement	Ref. A1	Ref. A2	Ref. A3	Ref. A4
50cc	036-0515-003	036-0497-003	036-0524-003	036-0506-003
80cc	036-0516-003	036-0498-003	036-0525-003	036-0507-003
100cc	036-0517-003	036-0499-003	036-0526-003	036-0508-003
130cc	036-0518-003	036-0500-003	036-0527-003	036-0509-003
160cc	036-0519-003	036-0501-003	036-0528-003	036-0510-003
195cc	036-0520-003	036-0502-003	036-0529-003	036-0511-003
245cc	036-0521-003	036-0503-003	036-0530-003	036-0512-003
305cc	036-0522-003	036-0504-003	036-0531-003	036-0513-003
395cc	036-0523-003	036-0505-003	036-0532-003	036-0514-003

XLH and XLS spool valve motor series

XLS performance data

Performance data is typical at 25 cSt (12 SUS). Actual data may vary slightly from unit to unit in production.

XLS 050cc motor

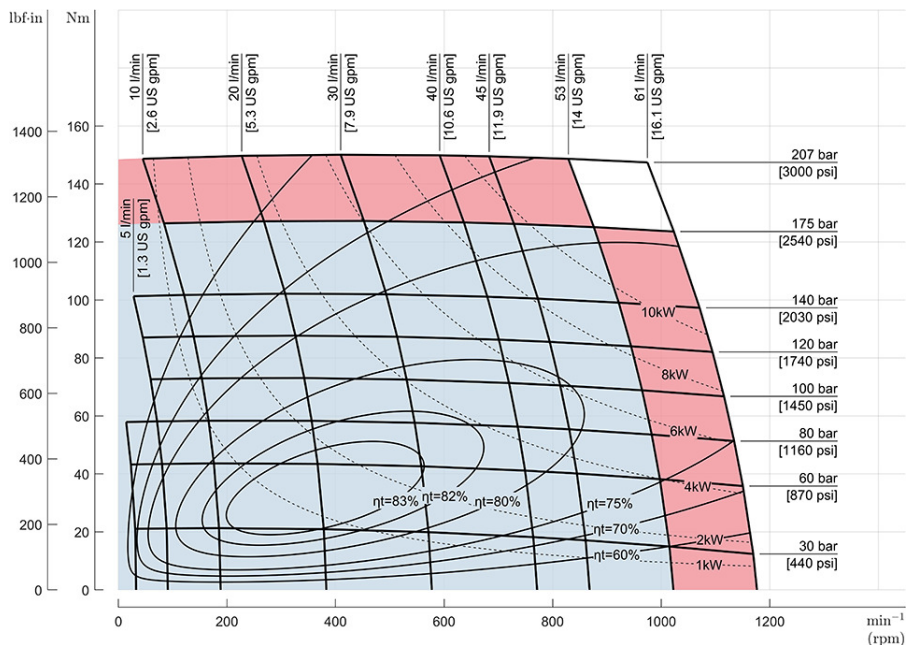

XLS 080cc motor

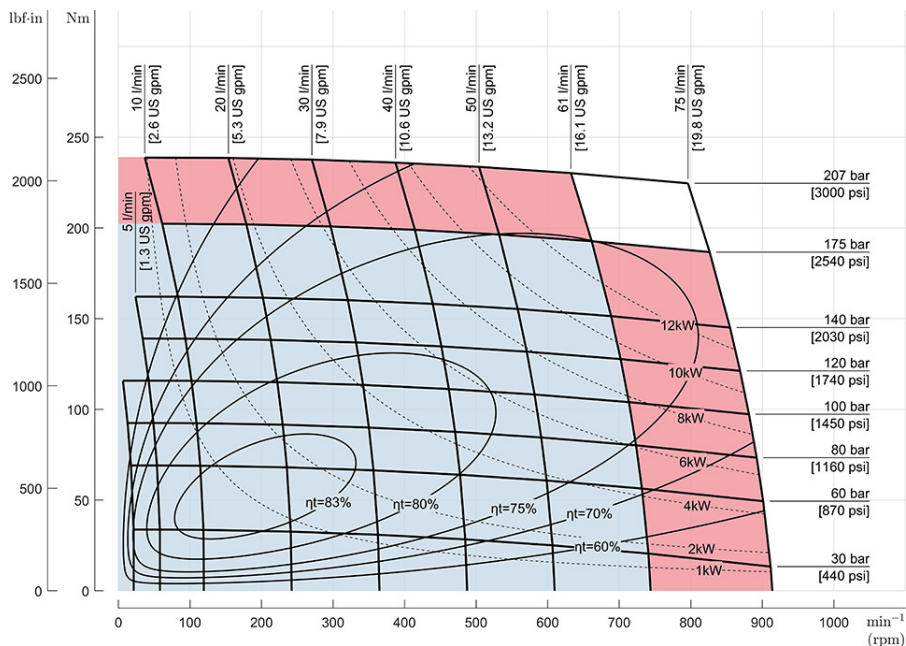

XLH and XLS spool valve motor series

XLS 100cc motor

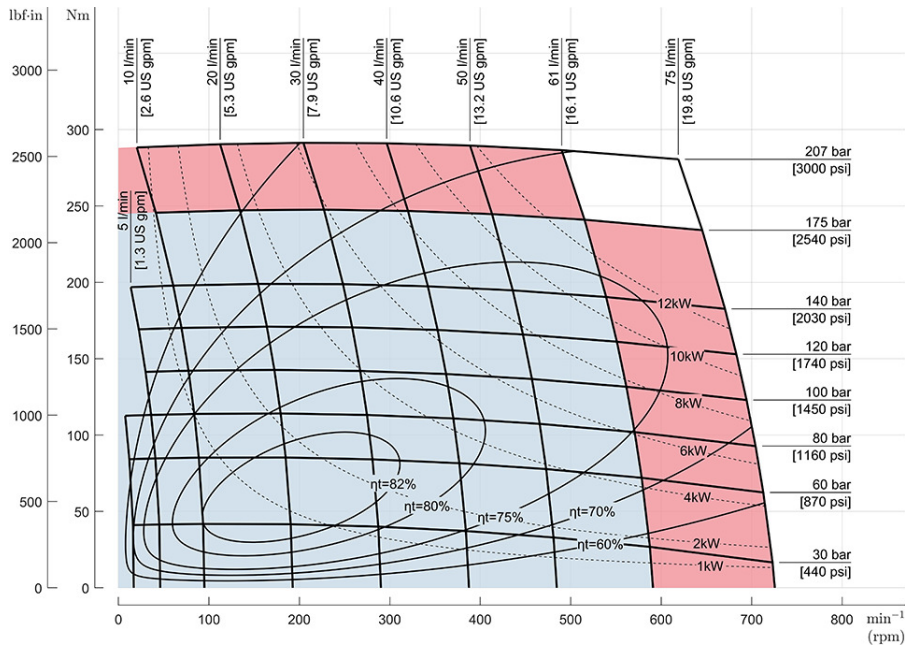

XLS 130cc motor

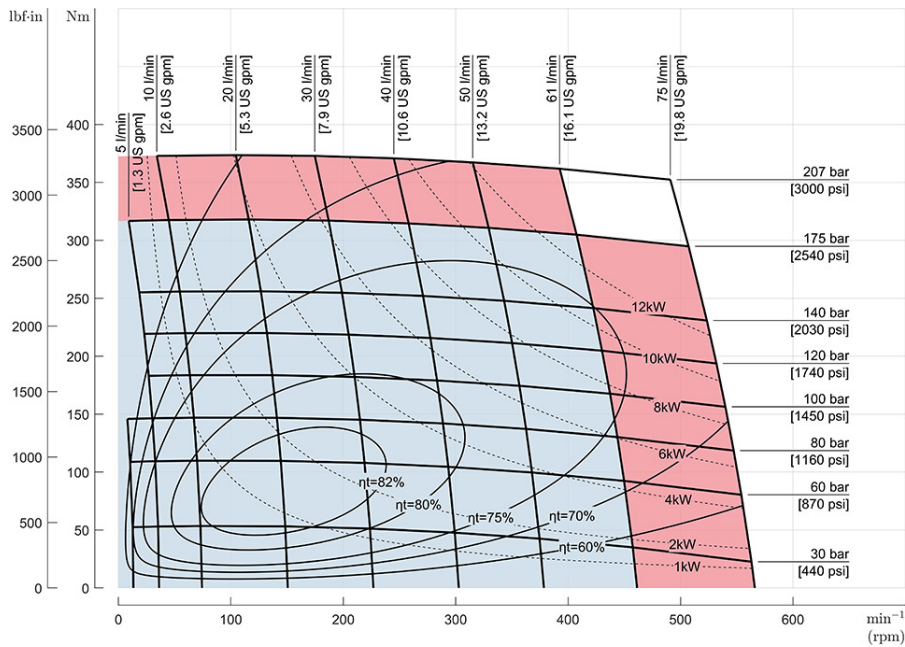

XLH and XLS spool valve motor series

XLS 160cc motor

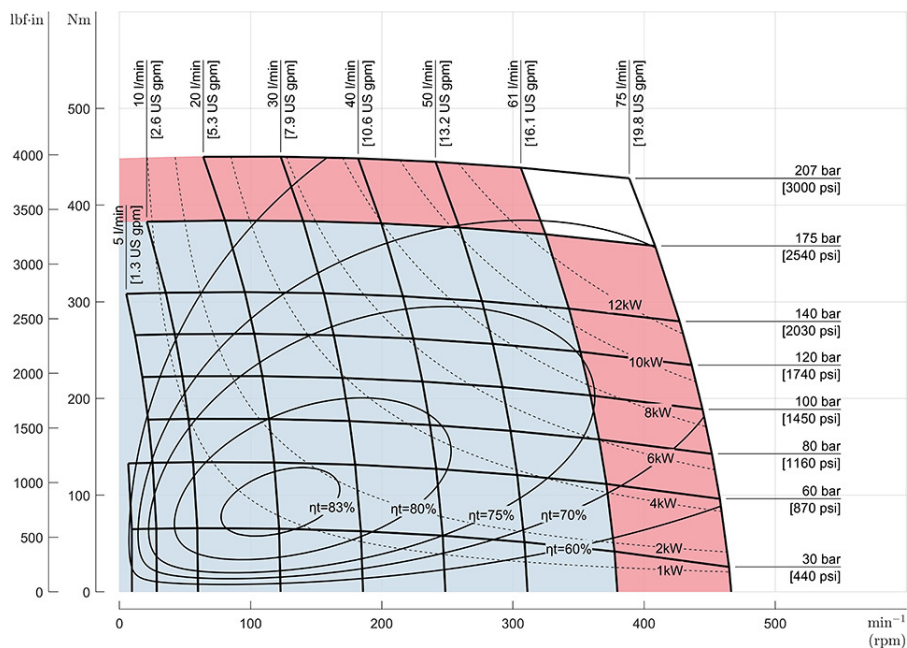

XLS 195cc motor

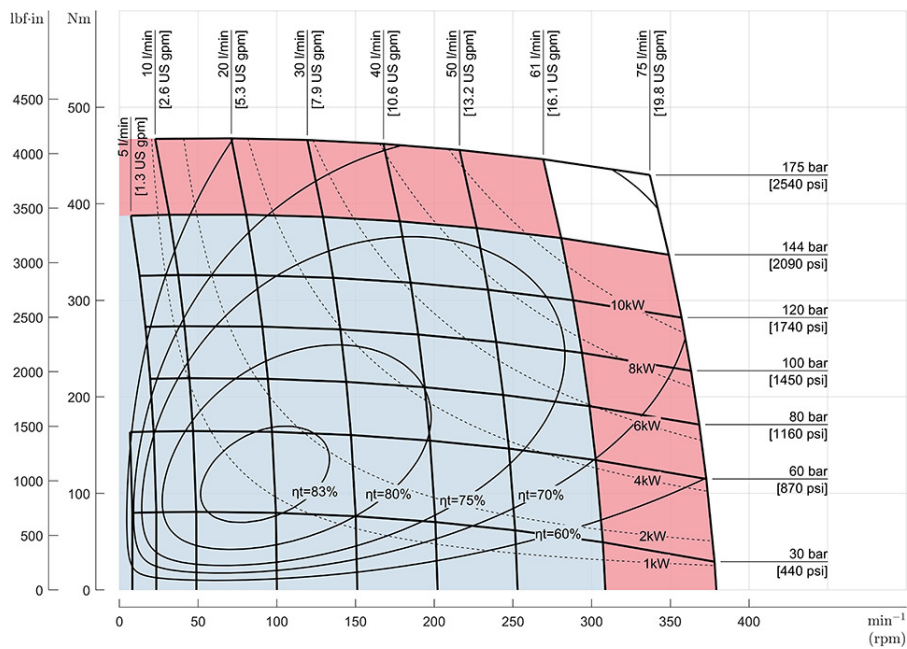

XLH and XLS spool valve motor series

XLS 245cc motor

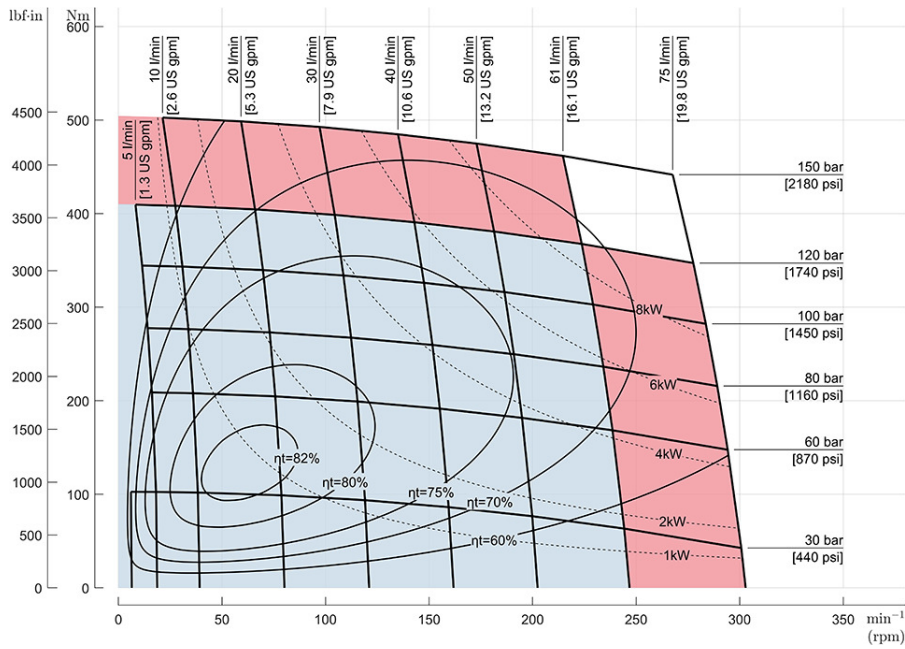

XLS 305cc motor

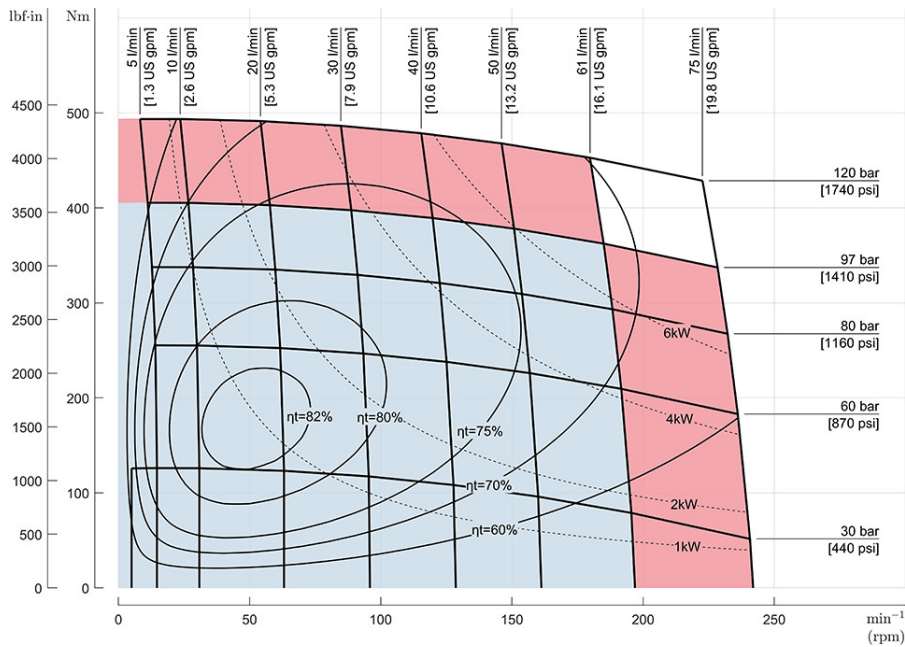

XLH and XLS spool valve motor series

XLS 395cc motor

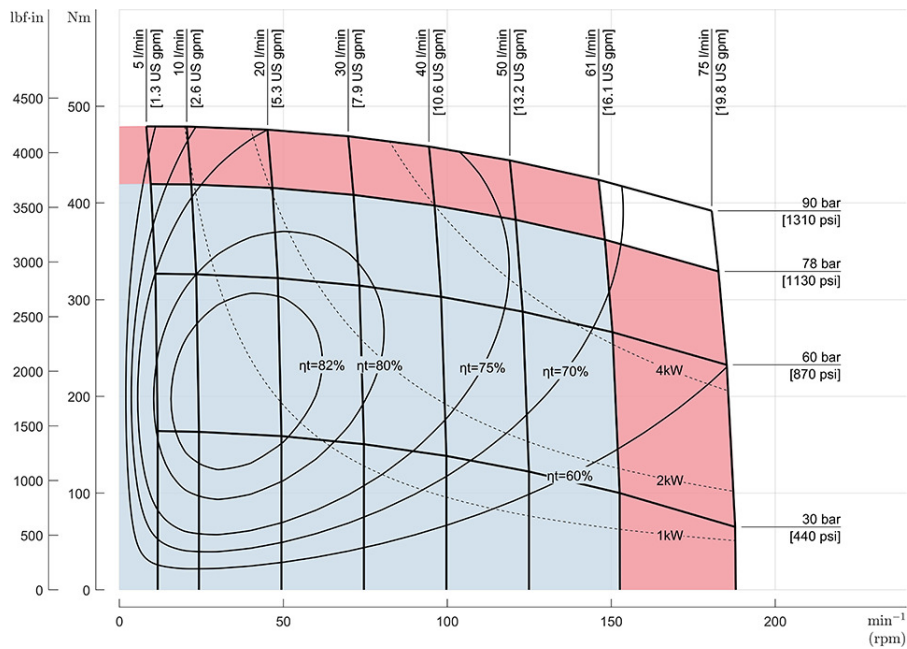

XLH and XLS spool valve motor series

XLS dimensions

Standard rotation viewed from shaft end

- Port A pressurized – CW
- Port B pressurized – CCW
- XLS standard shaft seal and section seal kit number: Z331-25
- XLS high pressure shaft seal and section seal kit number: Z331-59

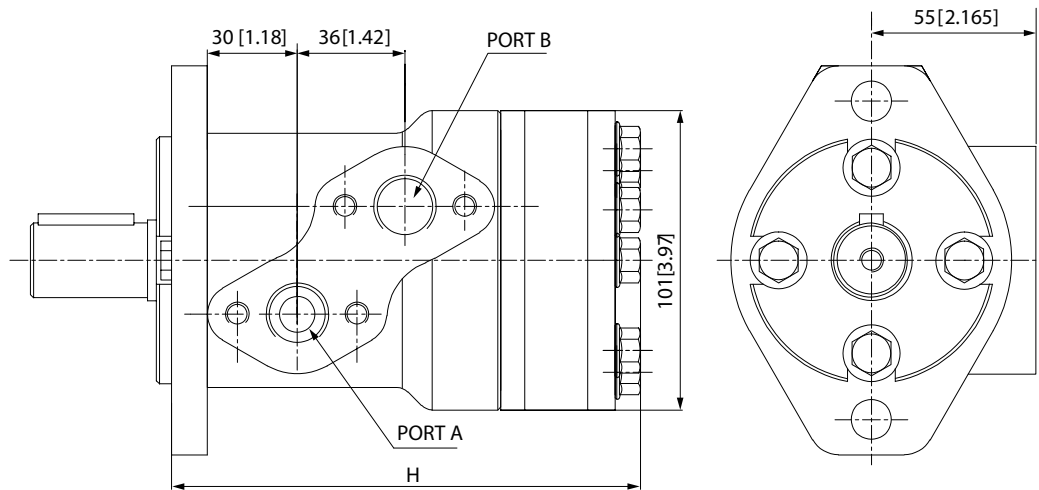

Dimension "H"

Displacement cm ³ /r [in ³ /r]	"H" mm [in]
53 [3.1]	151 [5.94]
80 [4.9]	158 [6.22]
100 [6.2]	163 [6.42]
130 [8.0]	169 [6.65]
160 [9.6]	169 [6.65]
195 [11.9]	176 [6.93]
245 [14.9]	185 [7.28]
305 [18.7]	196 [7.72]
395 [24.0]	196 [7.72]

Data is based on mounting flange SAE A.

XLH and XLS spool valve motor series

XLS model code

The reference number in the model code corresponds with the product components.

Model code identification

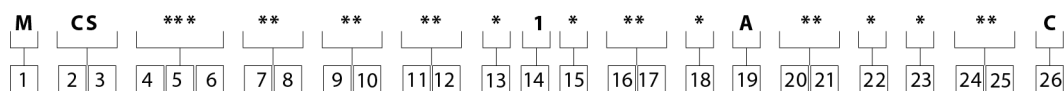

XLS product, series, displacement options

1 - product

Code	Description
M	Motor

2, 3 - series

Code	Description
CS	XLS series

4, 5, 6 - displacement

Code	Description
050	50 [3 .1]
080	80 [4 .9]
100	100 [6 .2]
130	130 [8 .0]
160	160 [9 .6]
195	195 [11 .9]
245	245 [14 .9]
305	305 [18 .7]
395	395 [24 .0]

XLS mounting flange and output shaft options

7, 8 - mounting flange

Code	Description
AA	2 bolt standard, SAE A, 82.55 x 5 pilot, pilot 2-13.5 dia. mounting holes on 106.4 dia.
AC	2 bolt standard, 82.55 x 2 .8 pilot, 2-13.5 dia. mounting holes on 106.4 dia.
AD	4 bolt standard, 44.40 dia. x 3.05 pilot, 375-16 UNC-2B, mounting holes on 82.55 dia. B.C.
AE	4 bolt standard, 44.40 dia. x 3.05 pilot, M10x1 .5-6H mounting holes on 82.55 dia. B.C.

XLH and XLS spool valve motor series

9, 10 - output shaft

Code	Description
05	25.4 dia. straight, parallel key, .250-20 UNC 2B hole in the shaft end
07	25.4 dia. splined shaft, SAE 6B, M8 X 1.25-6H thread in shaft end Extended length (54 mm from flange)
10	25 dia. straight, 5mm extra length parallel key A8 x 7 x 32, M8 thread in shaft end. Extended length (54 mm from flange)

Main ports, case drain, geroler options

11, 12 - main ports

Code	Description
AA	Staggered port 2-G1/2 ISO228/1 Manifold ports (4 x M8 mounting holes)
AE	Staggered port 2-0 .875-14 UNF-2B O-ring or manifold ports (4-M 8-6H mounting holes)

13 - case drain

Code	Description
1	G1/4 ISO228/1
3	0.4375-20 UNF-2B

14 - geroler

Code	Description
1	Standard geroler

Shaft, seal, speed sensor, manifold options

15 - shaft

Code	Description
1	Revision C design

16, 17 - shaft seal

Code	Description
00	Standard seals
02	High pressure shaft seal

18 - speed sensor

Code	Description
0	None

19 - manifold block

Code	Description
A	None

XLH and XLS spool valve motor series

Special features, assembly, identification options

20, 21 - special features

Code	Description
00	None

22 - special assembly instructions

Code	Description
0	None
1	Reverse rotation

23 - paint

Code	Description
C	Black primer

24, 25 - customer identification or nameplate

Code	Description
00	None

26 - design code

Code	Description
B	Second
C	Third

Mounting dimensions

XLH and XLS flange code AA

Dimensions in mm [in]

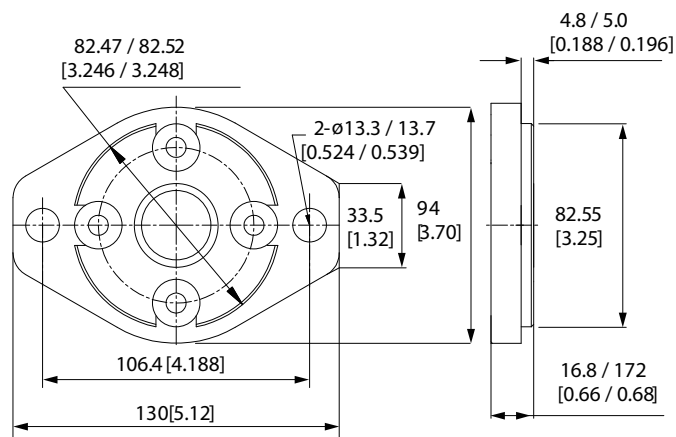

- SAE A
- 2 bolt
- Ø 82.55 x 5 [3.25 x 0.196] pilot

XLH and XLS spool valve motor series

XLH and XLS code AC

Dimensions in mm [in]

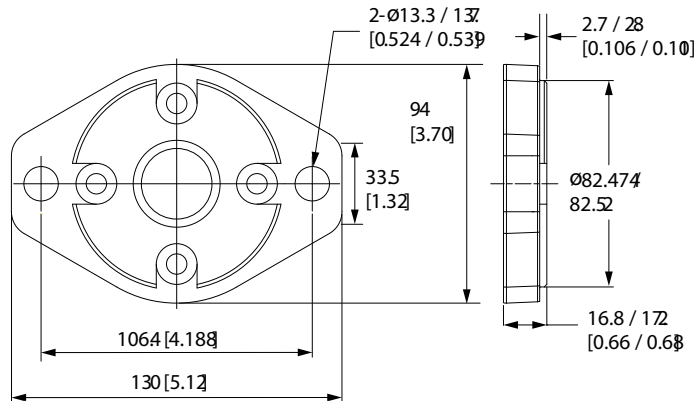

- SAE A
- 2 bolt
- Ø 82.55 x 2.5 [3.25 x 0.110] pilot

XLH and XLS flange code AD

Dimensions in mm [in]

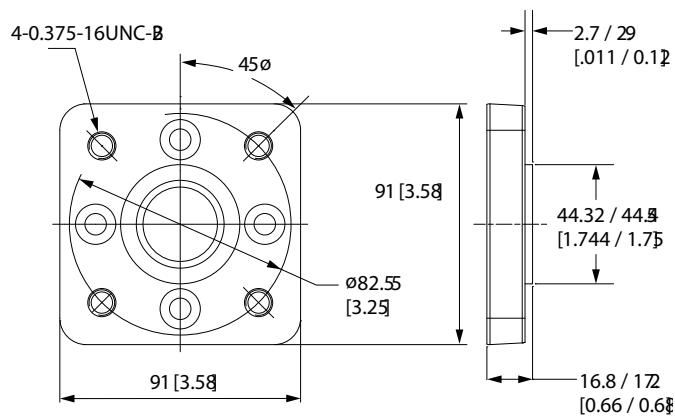

- SAE A
- 4 bolt
- Ø 44.40 [1.748] pilot

XLH and XLS spool valve motor series

XLH and XLS flange code AE

Dimensions in mm [in]

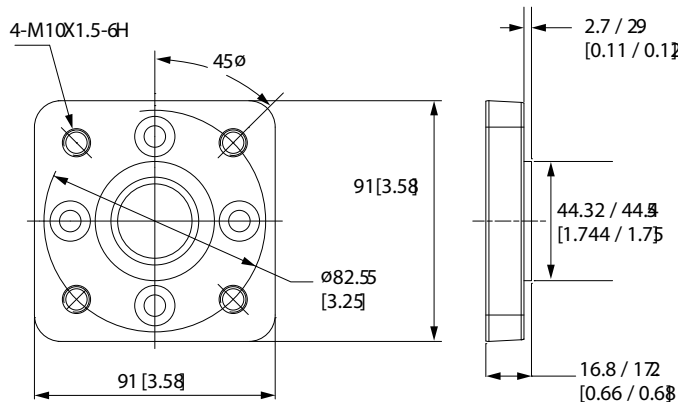

- SAE A
- 4 bolt
- $\varnothing 44.40$ [1.748] pilot
- Metric

XLH and XLS shaft dimensions

XLH shaft code 01

25mm straight shaft (code 01)

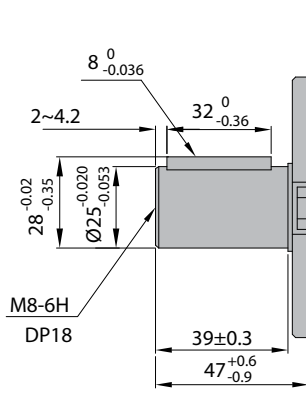

340 N·m [3008 in·lb] max. torque

XLH and XLS spool valve motor series

XLH shaft code 02

25mm straight shaft with 5mm extra length (code 02)

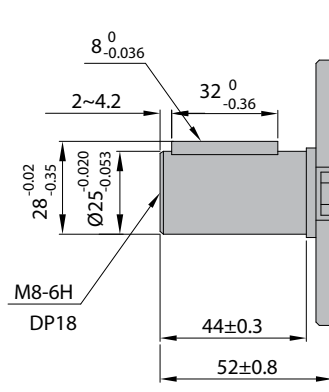

340 N·m [3008 in·lb] max. torque

XLH shaft code 03

Straight shaft (code 03)

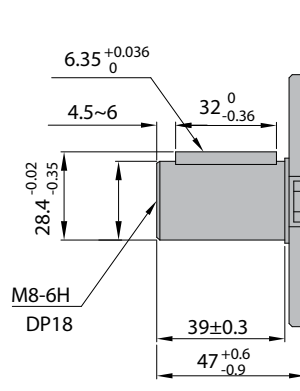

340 N·m [3008 in·lb] max. torque

XLH shaft code 04

SAE 6B spline (code 04)

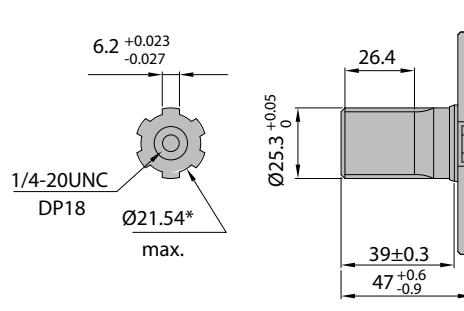

* Deviates from SAE J499

400 N·m [3540 in·lb] max. torque

XLH and XLS spool valve motor series

XLH and XLS shaft code 05

25.4 [1.00] straight shaft (code 05)

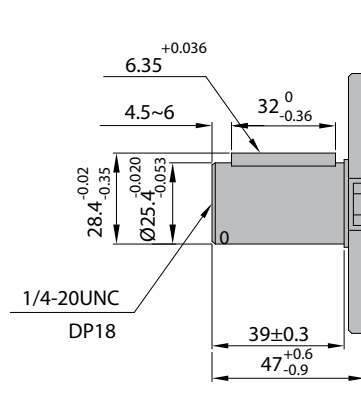

340 N·m [3008 in·lb] max. torque

XLH and XLS shaft code 07 dimensions

6B spline shaft 7mm extra length (code 07)

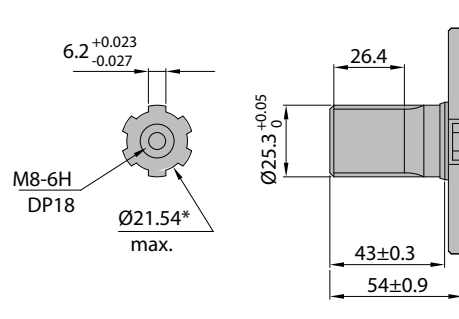

* Deviates from SAE J499

400 N·m [3540 in·lb] max. torque

XLH shaft code 08

25.4 [1.00] straight shaft with crosshole (code 08)

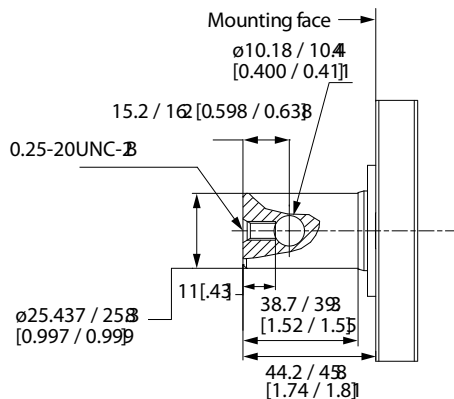

338 N·m [3000 in·lb] max. torque

XLH and XLS spool valve motor series

XLH and XLS shaft code 10

25mm straight shaft 7mm extra length (code 10)

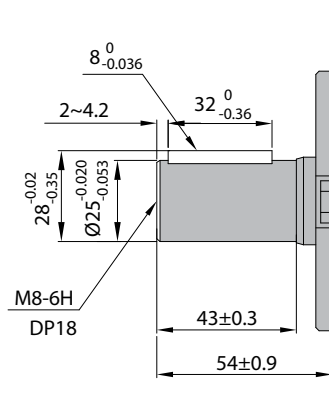

340 N·m [3008 in·lb] max. torque

Ports

XLH and XLS ports code AA

Code AA

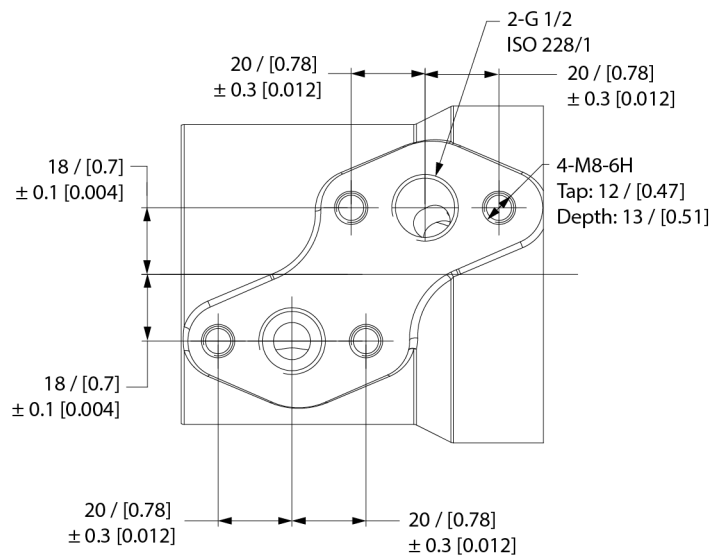

XLH and XLS spool valve motor series

XLH and XLS ports code AE

Code AE

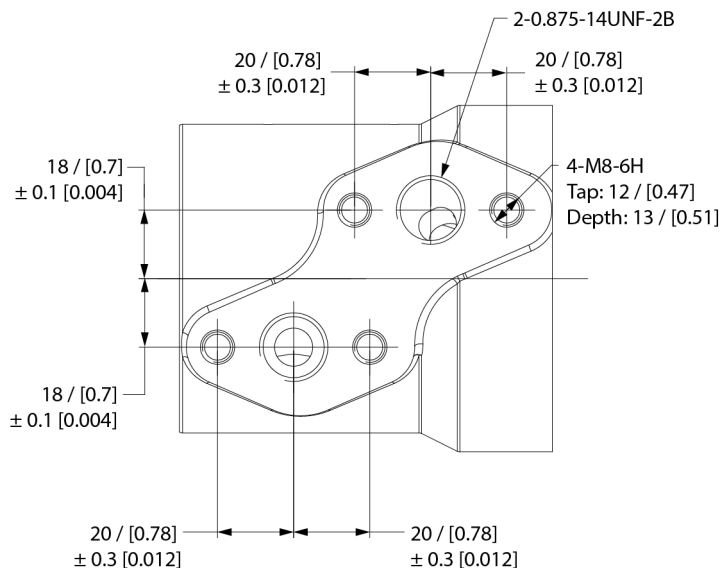

XLH and XLS side load capacity

Side load per rpm

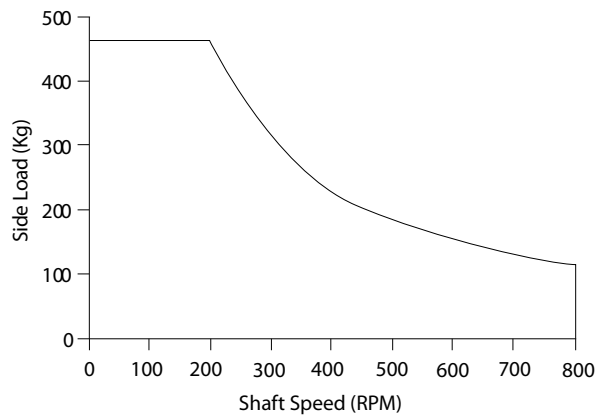

XLH and XLS spool valve motor series

Side load calculation

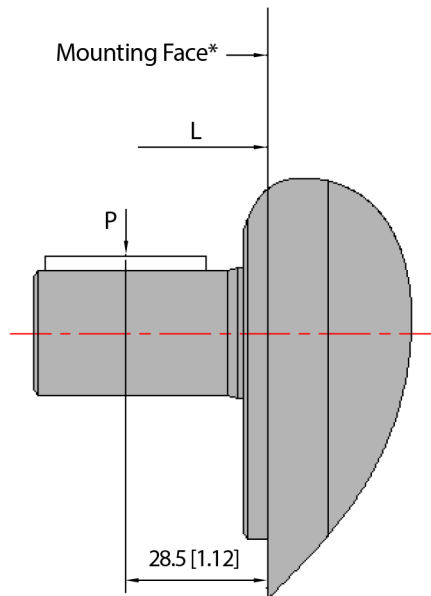

$P = 800/N (15000/L+100)$ from 200-800 rpm.

- N** Shaft speed (rpm)
- L** Distance from mounting surface
- P** Side load (kg)

XLH and XLS spool valve motor series

XLH and XLS case pressure seal limitation

Allowable case pressure is highest at low shaft speeds. Motor life will be shortened if case pressure exceeds recommended ratings.

Case pressure is as follows:

$$P_c = 0.6\Delta P + P_2 \quad \Delta P = P_1 - P_2$$

P_c	Case pressure
P₁	Inlet line pressure
P₂	Outlet pressure

The motor life is extended when using a case drain line. Case drain line with:

- Contamination control - flushing the motor case
- Motor cooling - exiting oil draws motor heat away
- Extends motor seal life - maintain low case pressure with a preset restriction installed in the case drain line.

When case drain line is used, make sure the motor is always filled with oil.

XLH series only

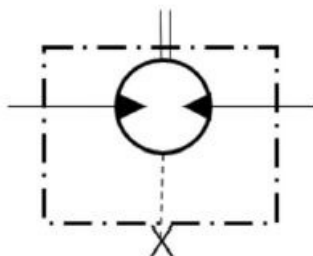

XLS series only

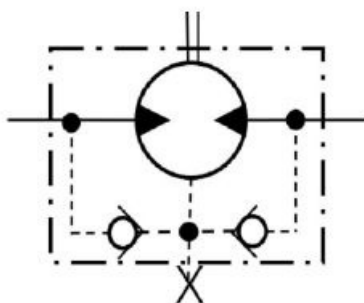

XLH and XLS spool valve motor series

XLH and XLS shaft seal performance graphs

Standard shaft seal

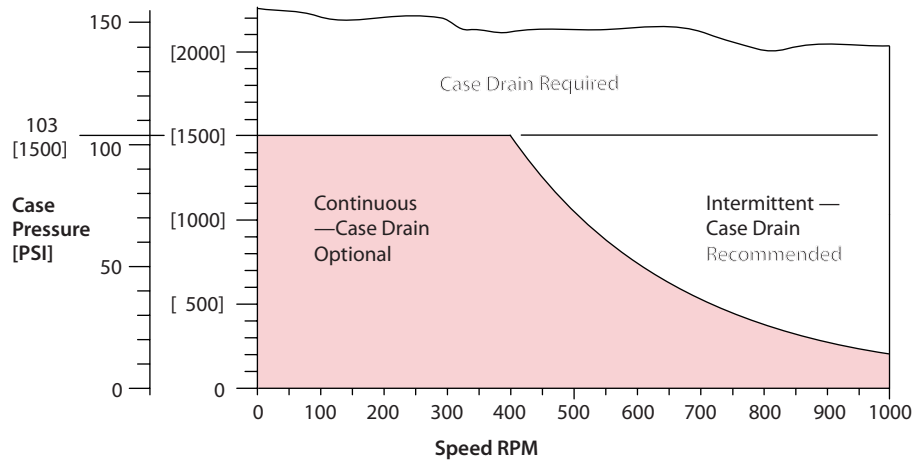

High pressure shaft seal

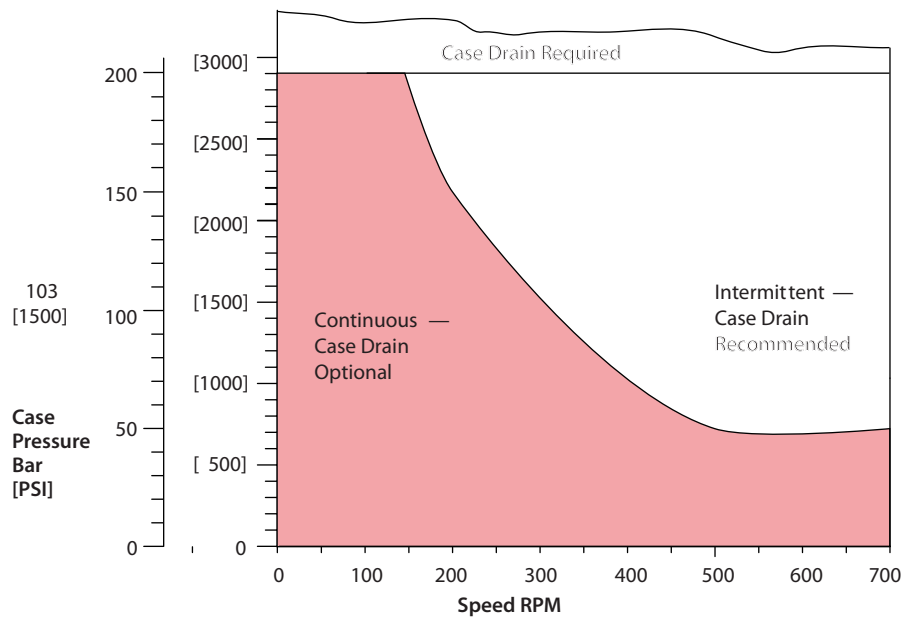

XL2 disc valve motor series

About the XL2 series motors

Danfoss' Xcel™ series low speed, high torque disc valve motors offer the most popular features and options from the Danfoss Char-Lynn range and are optimized to bring the highest value in medium duty applications.



XL2 series features, benefits, and applications

Features

- Three zone design for longer life and true bi-directionality
- Bearings that meet the highest standards of the industry
- Options to optimize performance in every application
- Integrated cross-over relief and counterbalance valve options

Benefits

- Easy to design in a system
- Reliability in multiple applications
- Integrated valve options to minimize installed size and weight

Applications

- Augers
- Sweepers
- Snow blowers
- Conveyors

XL2 disc valve motor series

XL2 specifications overview

XL2 series specifications

Parameter	Data
Geroler element	9 displacements
Flow l/min [US gal/min]	75 [20] continuous 115 [30] intermittent
Speed rpm	908 continuous 924 intermittent
Pressure bar [psi]	205 [3000] continuous 310 [4500] intermittent
Torque N·m [lb·in]	845 [7470] continuous 930 [8225] intermittent

Continuous motor may run continuously at the listed ratings

Intermittent 10% of every minute

XL2 disc valve motor series

XL2 part identification

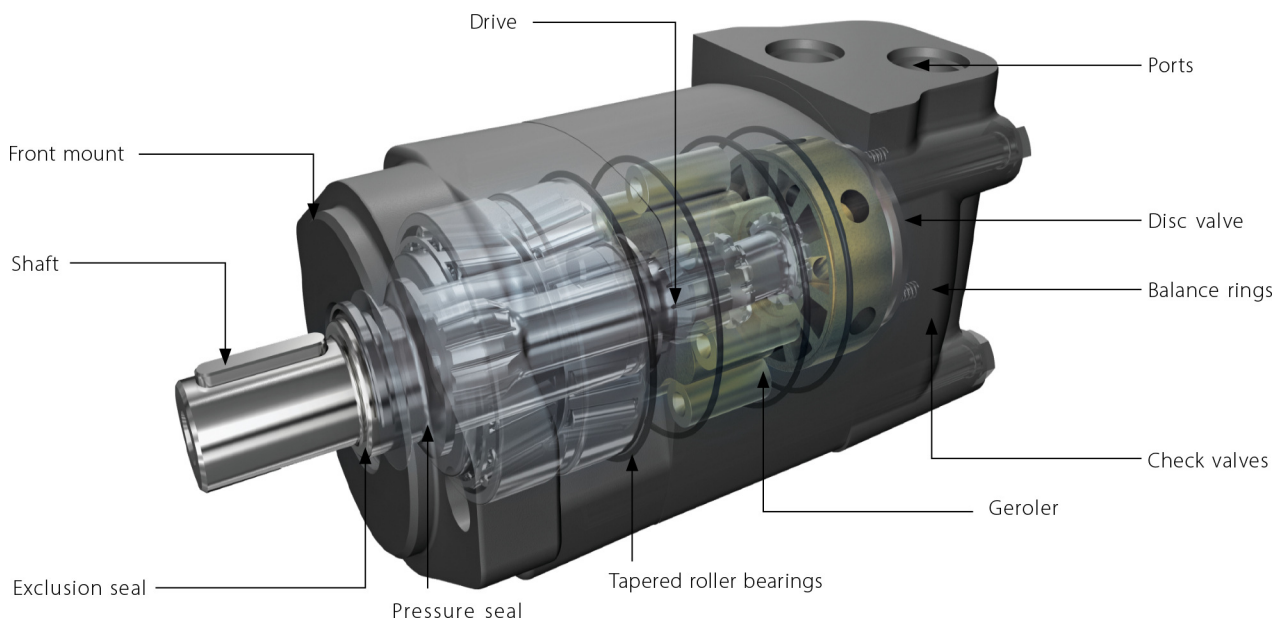

XL2 technical data

XL2 80cc-195cc technical data

Displacement cm³/r [in³/r]		80 [4.9]	100 [6.1]	130 [7.9]	160 [9.8]	195 [11.9]
Flow l/min [US gal/min]	Continuous	75 [20]	75 [20]	75 [20]	75 [20]	75 [20]
	Intermittent	75 [20]	95 [25]	95 [25]	115 [30]	115 [30]
Speed rpm	Continuous	908	739	575	477	385
	Intermittent	908	924	719	713	577
Pressure Δbar [Δpsi]	Continuous	205 [3000]	205 [3000]	205 [3000]	205 [3000]	205 [3000]
	Intermittent	310 [4500]	310 [4500]	310 [4500]	260 [3771]	260 [3771]
Torque N·m [lb·in]	Continuous	235 [2080]	295 [2611]	385 [3407]	455 [4027]	540 [4779]
	Intermittent	345 [3053]	445 [3938]	560 [4956]	570 [5045]	665 [5885]
Weight kg [lbs]	Standard or wheel mount	9.3 [20.5]	9.5 [20.9]	9.8 [21.6]	10.0 [22]	10.4 [22.9]
	Bearingless	7.3 [16.1]	7.5 [16.5]	7.7 [17]	7.9 [17.4]	8.4 [18.5]

XL2 245cc-490cc technical data

Displacement cm³/r [in³/r]		245 [15]	305 [18.6]	395 [24.1]	490 [29.9]
Flow l/min [US gal/min]	Continuous	75 [20]	75 [20]	75 [20]	75 [20]
	Intermittent	115 [30]	115 [30]	115 [30]	115 [30]
Speed rpm	Continuous	308	246	191	153
	Intermittent	462	365	287	230
Pressure Δbar [Δpsi]	Continuous	205 [3000]	205 [3000]	155 [2248]	120 [1740]
	Intermittent	260 [3771]	240 [3481]	170 [2466]	140 [2031]
Torque N·m [lb·in]	Continuous	660 [5841]	765 [6770]	775 [6859]	845 [7478]
	Intermittent	820 [7257]	885 [7832]	925 [8186]	930 [8231]
Weight kg [lbs]	Standard or wheel mount	10.8 [24]	11.3 [24.9]	11.8 [26]	12.2 [26.9]
	Bearingless	8.8 [19.4]	9.3 [20.5]	9.8 [21.6]	10.2 [22.5]

XL2 disc valve motor series

Δ bar [psi]	The true pressure difference between inlet port and outlet port.
Continuous rating	Motor may be run continuously at these ratings.
Intermittent operation	10% of every minute.

To ensure best motor life, run motor for approximately 1 hour at 30% of rated pressure before application to full load. Be sure motor is filled with fluid prior to any load applications.

XL2 recommended operating parameters

Data	Recommended
Max. inlet pressure	310 bar [4500 psi]  Caution Do not exceed Δ pressure rating
Fluids	Premium quality, anti-wear type hydraulic oil with a viscosity of no less than 13 cSt [70 SUS] at operating temperature.
Operating temperature	-34 to 82 °C [-30 to 180 °F]
Filtration	Per ISO cleanliness code 4406:20/18/13

XL2 disc valve motor series

XL2 product numbers

Design specification

Flange	Standard 4 bolt flange (AH)			Standard 2 bolt flange (AC)	Bearingless 4 bolt flange (AZ)
	Ref. A1	Ref. A2	Ref. A3	Ref. A4	Ref. A5
Flange pilot diameter	Ø 82.5 mm [3.25 in]			Ø 82.5 mm [3.25 in]	Ø 199 mm [3.94 in]
Flange bolt circle diameter	Ø 106.4 mm [4.20 in]			Ø 106.4 mm [4.20 in]	Ø 125 mm [4.92 in]
Shaft	Cyl. Ø32 mm (16)	Spline Ø31.75, 14T (99)	Tapered Ø35, cone 1:10 (41)	Cyl. Ø32 mm (16)	None, European splines (39)
Main port	G ½ (AS)	G ½ (AS)	G ½ (AS)	G ½ (AS)	G ½ (AS)
Drain port	G ¼	G ¼	G ¼	G ¼	G ¼
Shaft seal	Standard pressure shaft seal				None
Paint	Painted black				

Product numbers

Displacement	Ref. A1	Ref. A2	Ref. A3	Ref. A4	Ref. A5
80cc	629AG00715A	629AG00733A	629AG00724A	629AG00742A	631AG00056A
100cc	629AG00716A	629AG00734A	629AG00725A	629AG00743A	631AG00025A
130cc	629AG00717A	629AG00735A	629AG00726A	629AG00744A	631AG00026A
160cc	629AG00718A	629AG00736A	629AG00727A	629AG00745A	631AG00033A
195cc	629AG00719A	629AG00737A	629AG00728A	629AG00746A	631AG00057A
245cc	629AG00720A	629AG00738A	629AG00729A	629AG00747A	631AG00058A
305cc	629AG00721A	629AG00739A	629AG00730A	629AG00748A	*
395cc	629AG00722A	629AG00740A	629AG00731A	629AG00749A	631AG00060A
490cc	629AG00723A	629AG00741A	629AG00732A	629AG00750A	N/A

* Contact the Danfoss sales team

XL2 disc valve motor series

XL2 performance data

Performance data is typical at 25 cSt (120 SUS). Actual data may vary slightly from unit to unit in production.

XL2 80cc motor

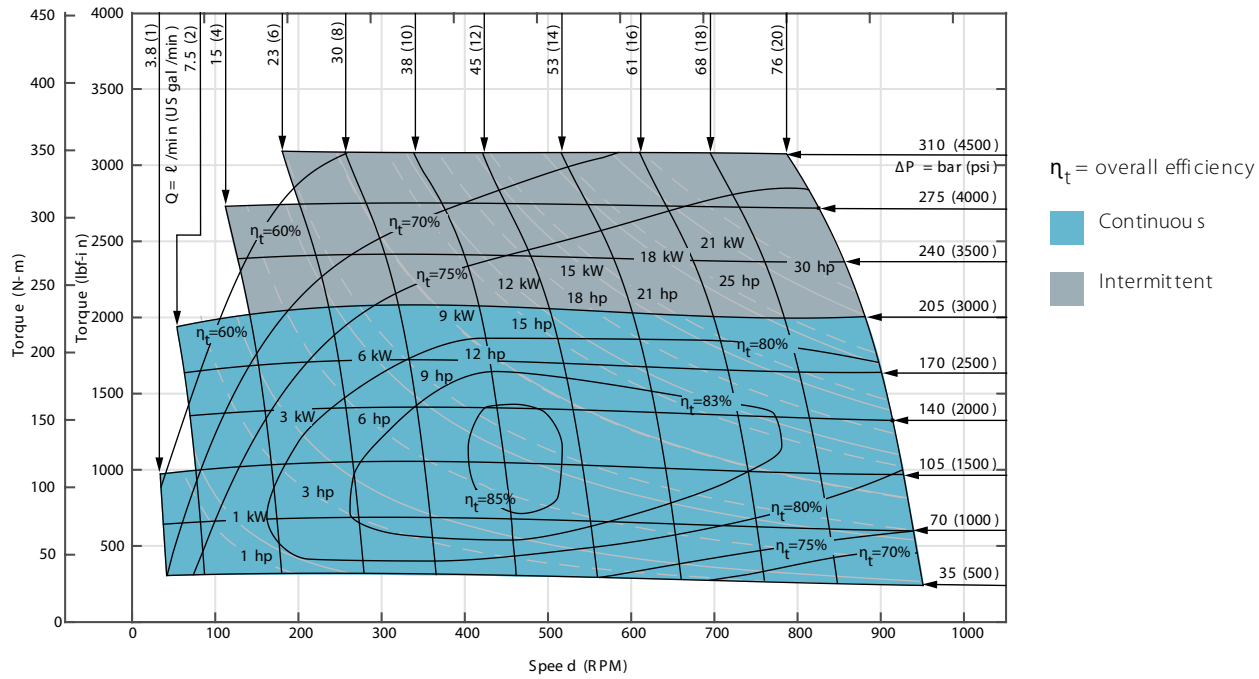

XL2 100cc motor

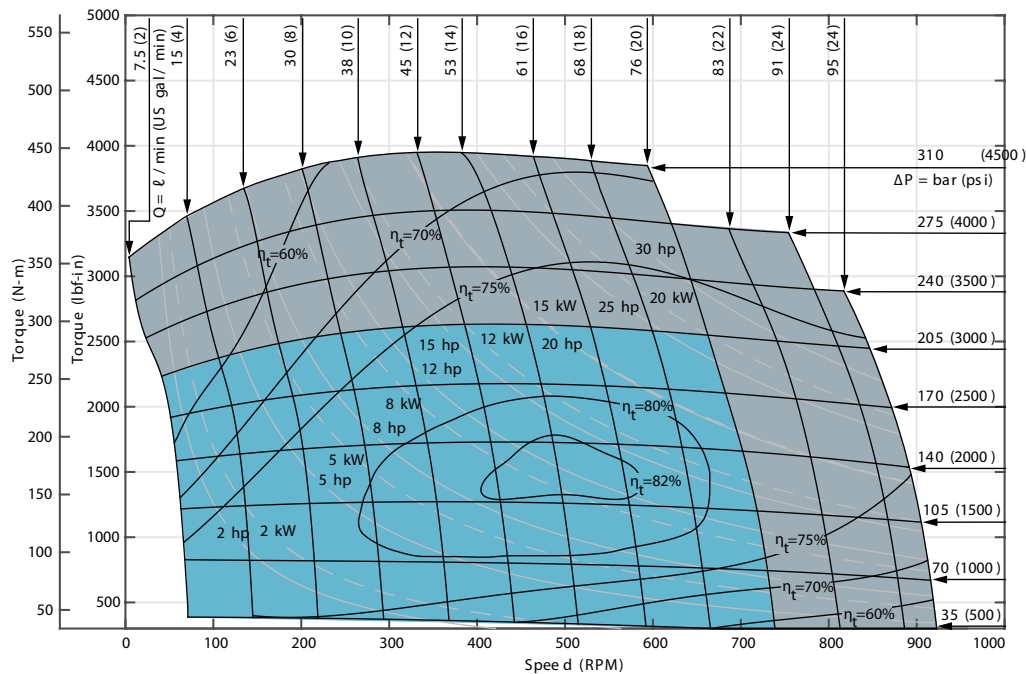

XL2 disc valve motor series

XL2 130cc motor

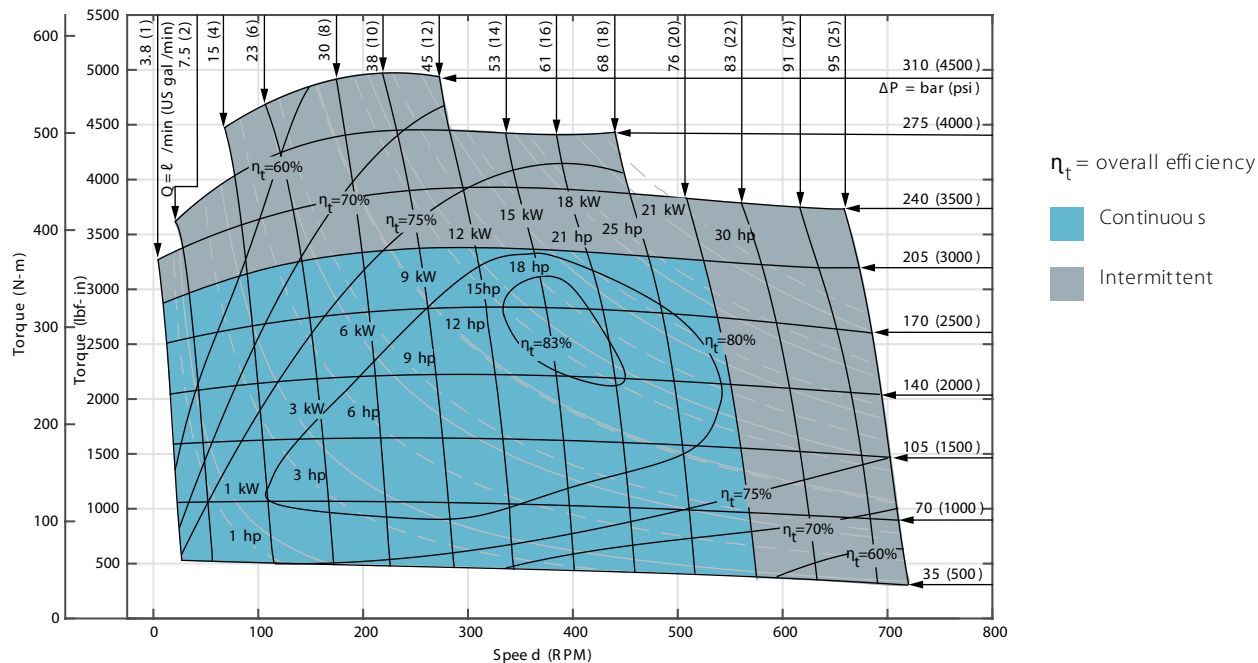

XL2 160cc motor

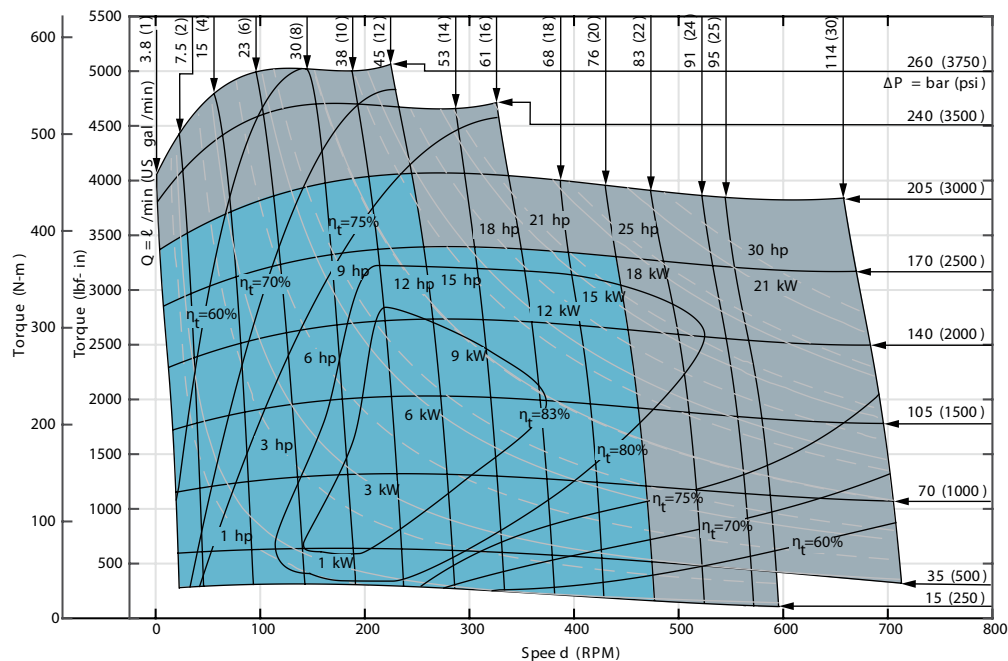

XL2 disc valve motor series

XL2 195cc motor

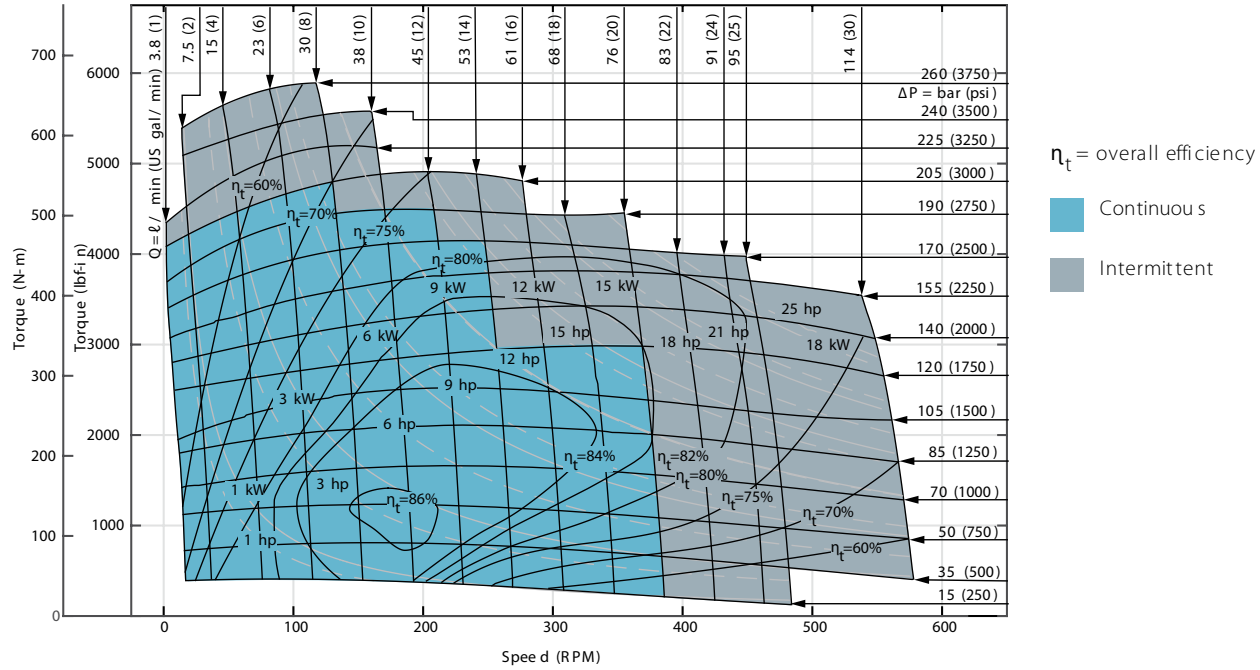

XL2 245cc motor

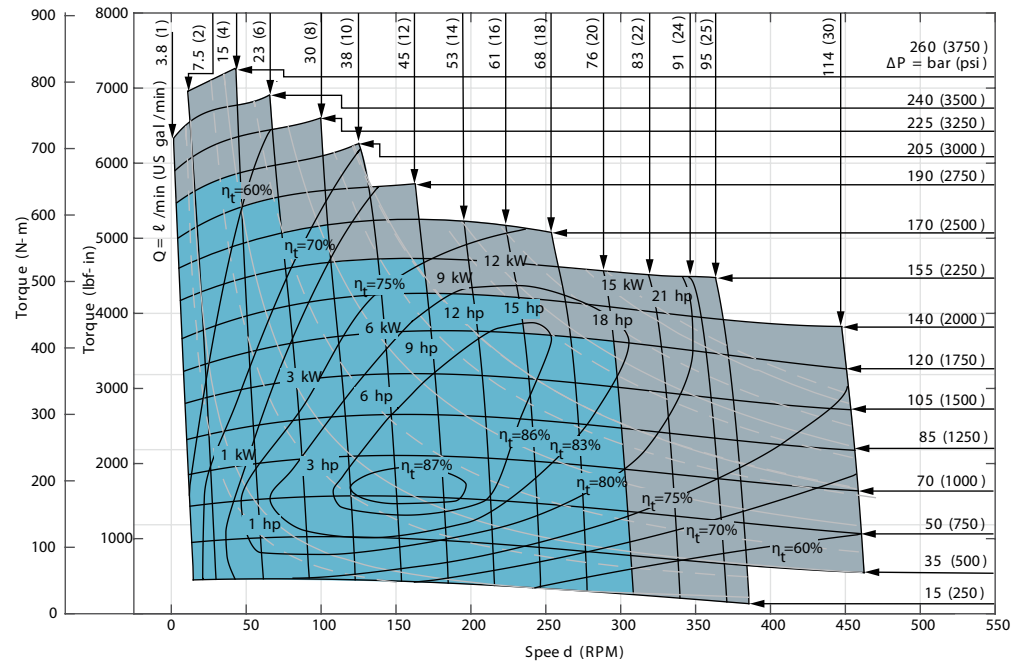

XL2 disc valve motor series

XL2 305cc motor

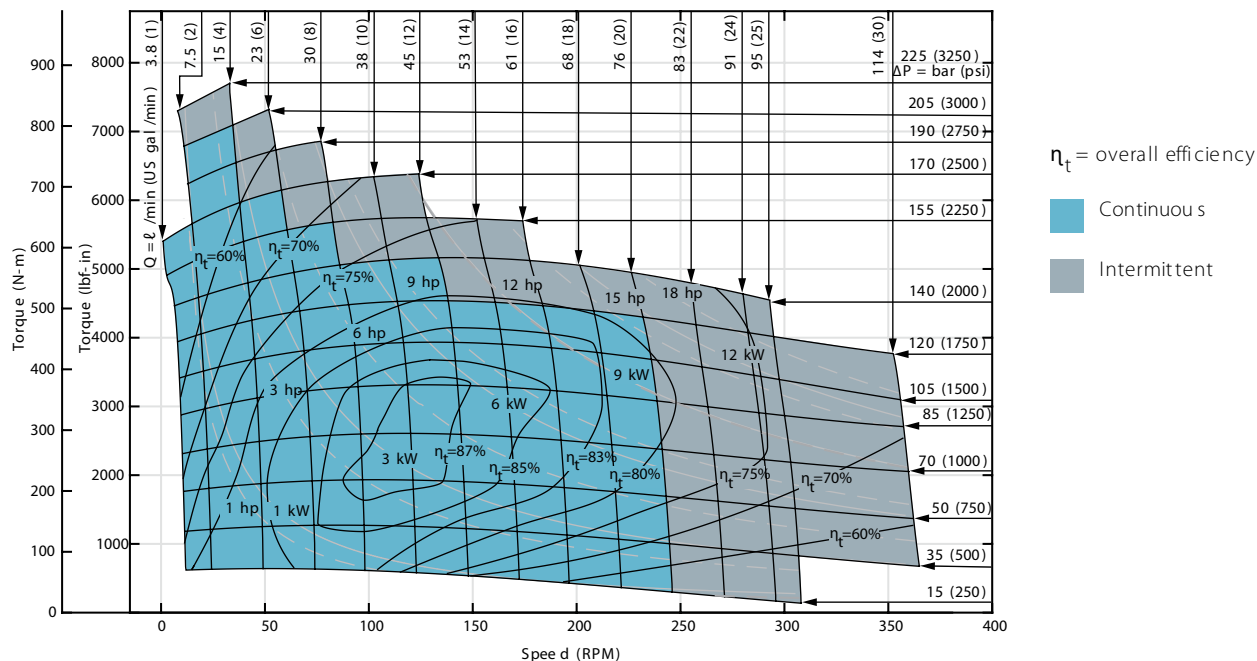

XL2 395cc motor

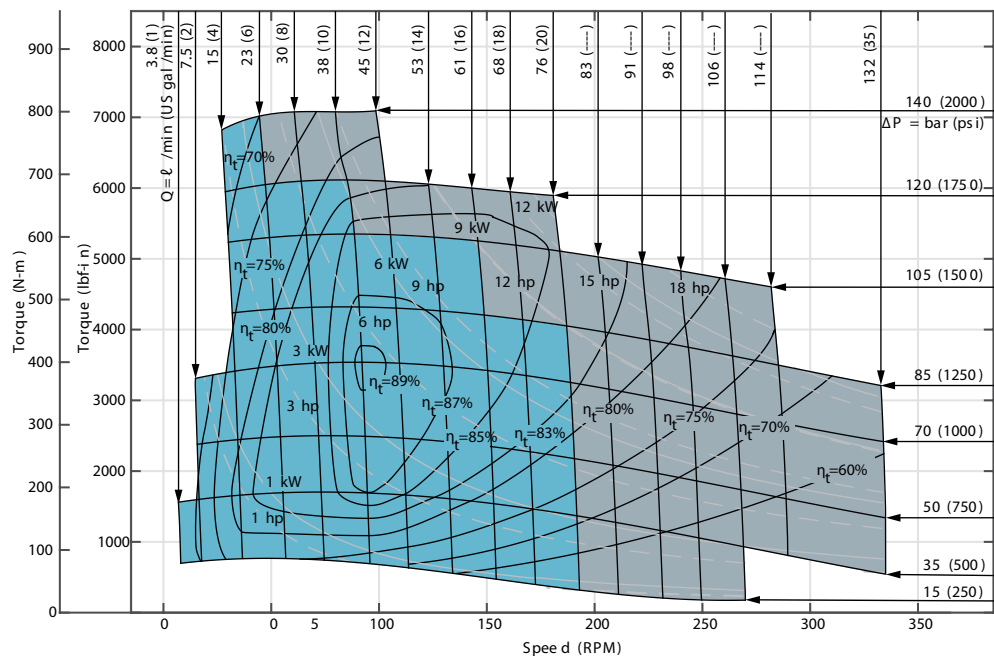

XL2 disc valve motor series

XL2 490cc motor

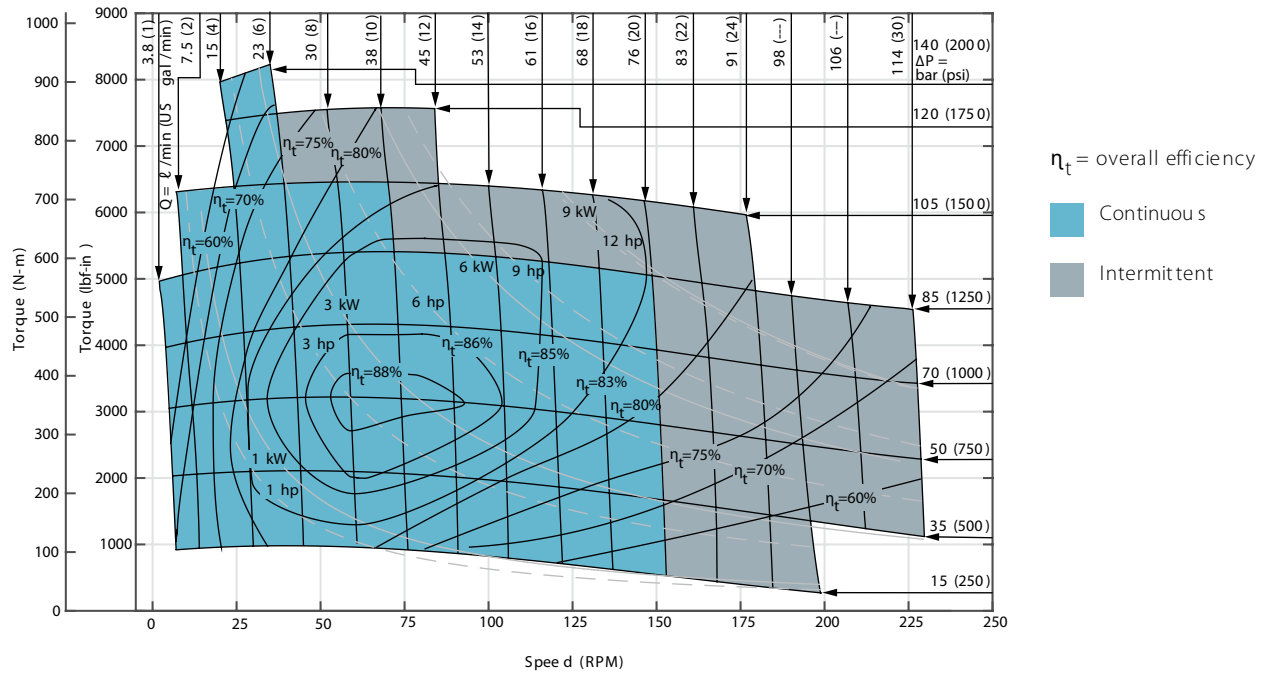

XL2 disc valve motor series

Standard and wheel mount dimensions

XL2 standard and wheel mount dimensions

Standard rotation viewed from shaft end

- Port A pressurized - CW
- Port B pressurized - CCW
- XL2 standard and wheel mount shaft seal and section seal kit number: Z331-02
- XL2 standard and wheel mount high pressure shaft seal and section seal kit number: Z331-51
- XL2 standard wheel mount high pressure shaft seal, seal guard, and section seal kit number: Z331-45

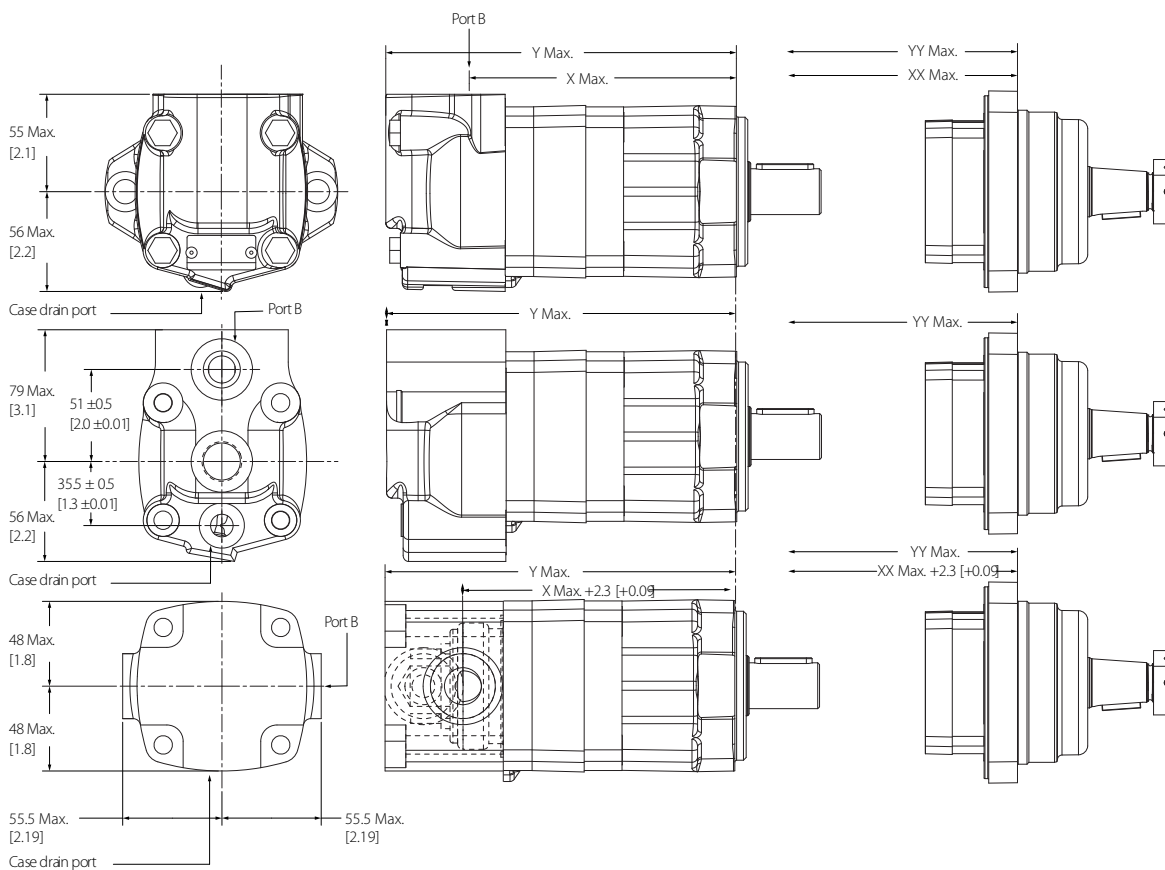

Dimensions

Displacement cm ³ /r [in ³ /r]	Dimension mm [in]			
	X	Y	XX	YY
80 [4.9]	136.9 [5.39]	184.2 [7.25]	96.9 [3.81]	144.3 [5.68]
100 [6.1]	141.5 [5.57]	189 [7.44]	101.4 [3.99]	148.9 [5.86]
130 [7.9]	147.9 [5.82]	195.4 [7.69]	107.8 [4.24]	155.2 [6.11]
160 [9.8]	147.9 [5.82]	195.4 [7.69]	107.8 [4.24]	155.2 [6.11]
195 [11.9]	154.7 [6.09]	202.2 [7.96]	114.6 [4.51]	162.1 [6.38]
245 [15]	163.7 [6.44]	211.1 [8.31]	123.5 [4.86]	171 [6.73]
305 [18.6]	175.1 [6.89]	222.3 [8.75]	135 [5.31]	182.4 [7.18]
395 [24.1]	191 [7.52]	238.6 [9.39]	151.5 [5.96]	198.4 [7.81]
490 [29.9]	208.4 [8.2]	255.8 [10.07]	168.2 [6.62]	215.7 [8.49]

XL2 disc valve motor series

XL2 standard and wheel mount with integral valve dimensions

Standard rotation viewed from shaft end

- Port A pressurized - CW
- Port B pressurized - CCW

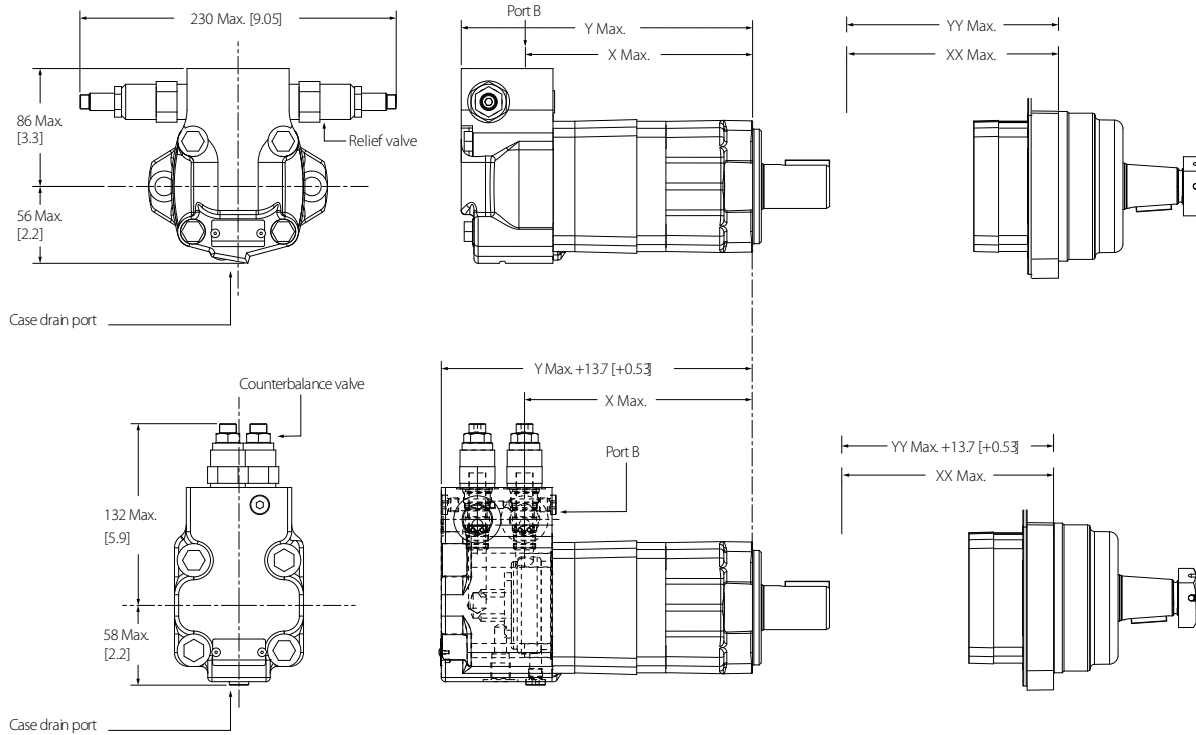

Dimensions

Displacement cm ³ /r [in ³ /r]	Dimensions mm [in]			
	X	Y	XX	YY
80 [4.9]	136.9 [5.39]	184.2 [7.25]	96.9 [3.81]	144.3 [5.68]
100 [6.1]	141.5 [5.57]	189 [7.44]	101.4 [3.99]	148.9 [5.86]
130 [7.9]	147.9 [5.82]	195.4 [7.69]	107.8 [4.24]	155.2 [6.11]
160 [9.8]	147.9 [5.82]	195.4 [7.69]	107.8 [4.24]	155.2 [6.11]
195 [11.9]	154.7 [6.09]	202.2 [7.96]	114.6 [4.51]	162.1 [6.38]
245 [15]	163.7 [6.44]	211.1 [8.31]	123.5 [4.86]	171 [6.73]
305 [18.6]	175.1 [6.89]	222.3 [8.75]	135 [5.31]	182.4 [7.18]
395 [24.1]	191 [7.52]	238.6 [9.39]	151.5 [5.96]	198.4 [7.81]
490 [29.9]	208.4 [8.2]	255.8 [10.07]	168.2 [6.62]	215.7 [8.49]

XL2 disc valve motor series

Relief valve and counterbalance valve schematics

Relief valve

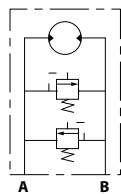

- RV3A-10-S -O-36
- CRV2-10-C-0-0-30

Counterbalance valve

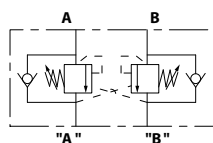

- 1CE30 (rated flow 30 l/min)

[Contact Danfoss for more detailed information about the relief valve and counterbalance valve.](#)

XL2 disc valve motor series

Bearingless dimensions

XL2 bearingless motor (AD) dimensions

Standard rotation viewed from shaft end

- Port A pressurized - CW
- Port B pressurized - CCW

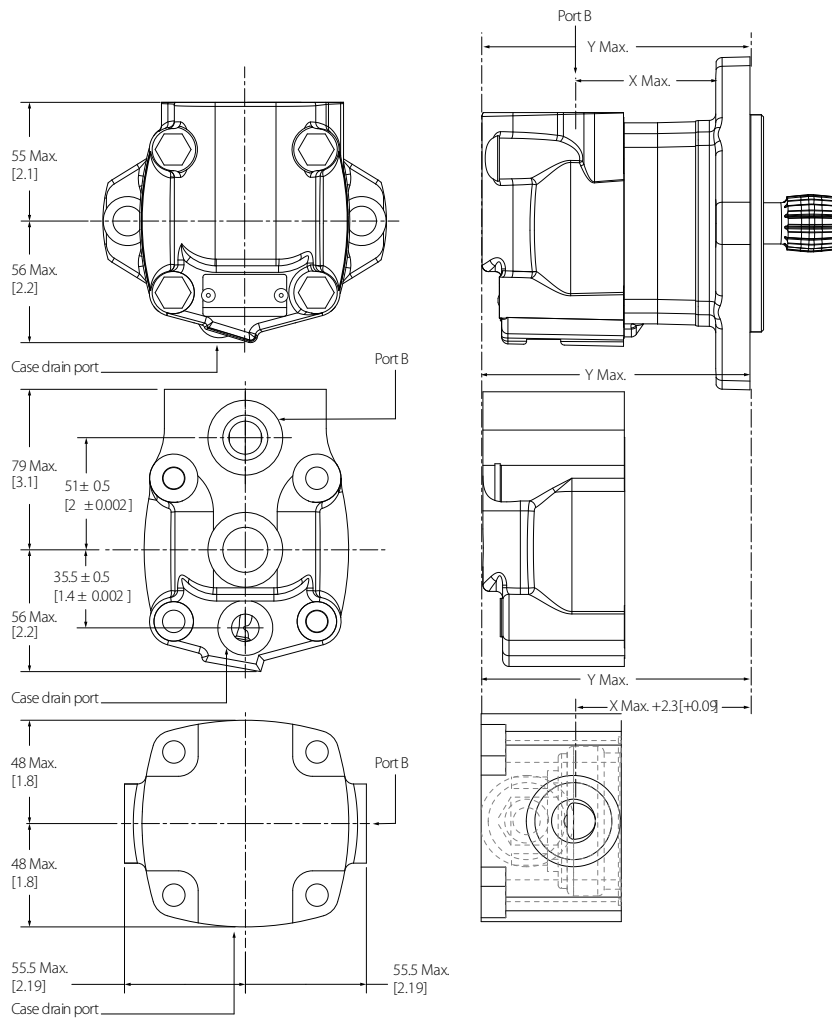

Dimensions

Displacement cm ³ /r [in ³ /r]	Dimensions mm [in]	
	X	Y
80 [4.9]	79 [3.11]	126.5 [4.98]
100 [6.1]	83.5 [3.29]	131.4 [5.17]
130 [7.9]	89.9 [3.54]	137.7 [5.42]
160 [9.8]	89.9 [3.54]	137.7 [5.42]
195 [11.9]	96.8 [3.81]	144.3 [5.68]
245 [15]	105.6 [4.16]	153.5 [6.04]
305 [18.6]	117.1 [4.61]	164.6 [6.48]

XL2 disc valve motor series

Dimensions (continued)

Displacement cm ³ /r [in ³ /r]	Dimensions mm [in]	
	X	Y
395 [24.1]	133.1 [5.24]	180.9 [7.12]
490 [29.9]	150.3 [5.92]	198.2 [7.8]

XL2 bearingless mount (AD) dimensions

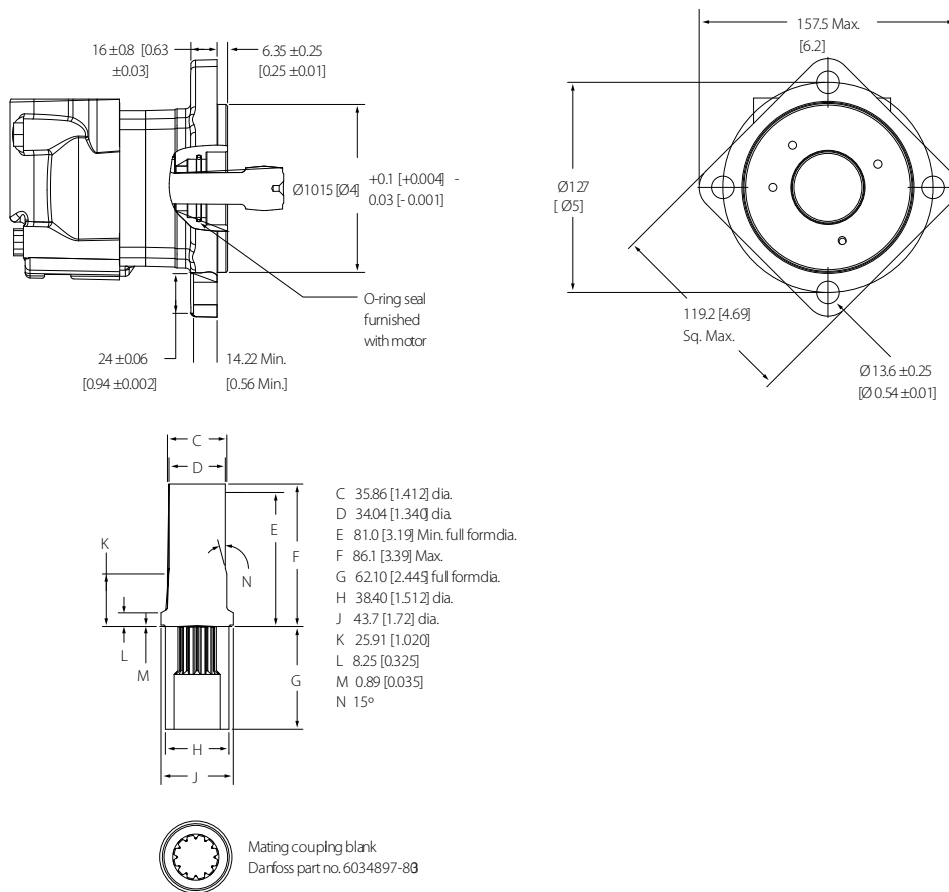

For Xcel XL2 series bearingless motor applications information, contact your Danfoss representative.

Mating coupling blanks available from Danfoss.

After machining blank, part must be hardened per Danfoss specification.

XL2 disc valve motor series

XL2 bearingless motor EMEA (AZ) dimensions

Standard rotation viewed from shaft end

- Port A pressurized - CW
- Port B pressurized - CCW

Bearingless motor EMEA (AZ)

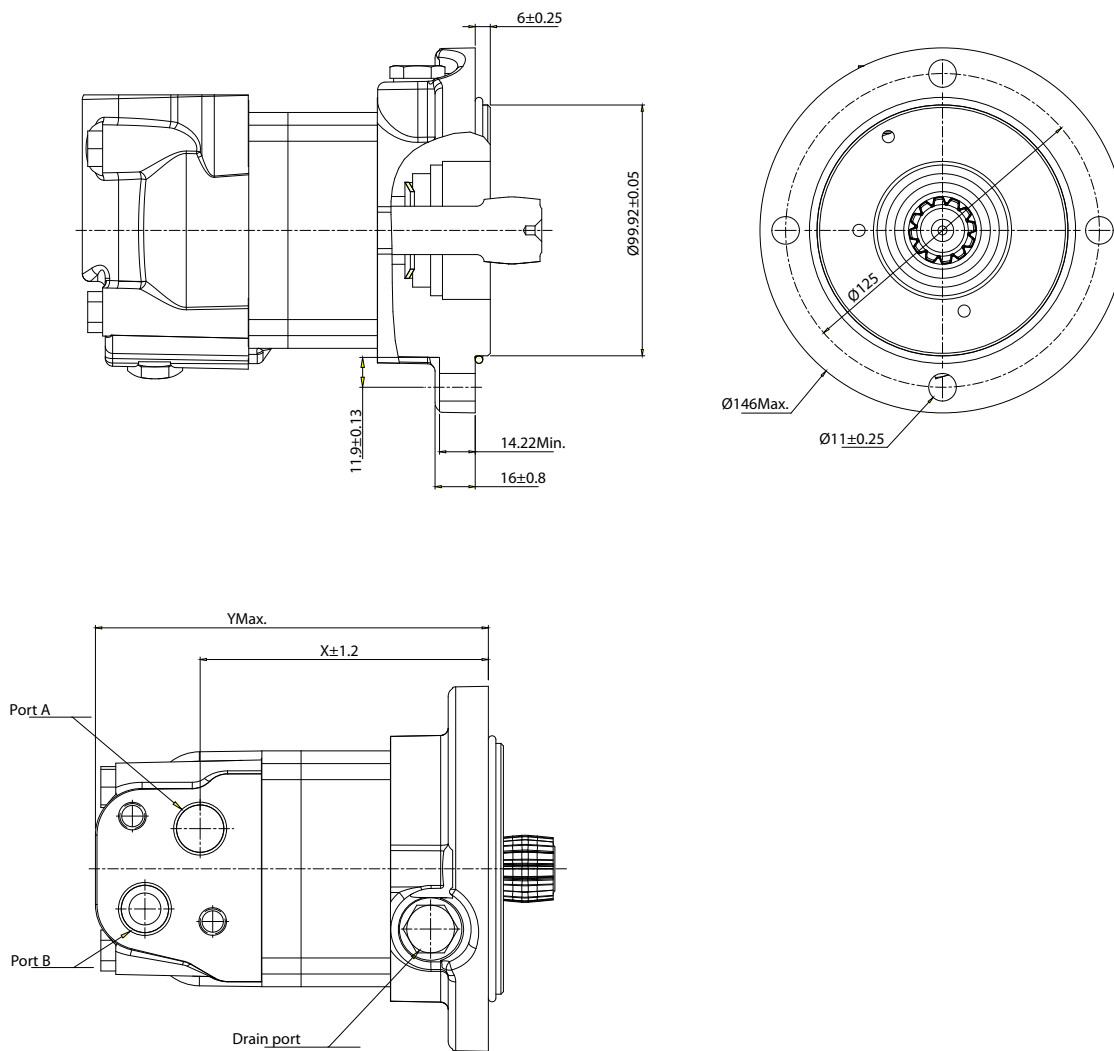

Dimensions

Displacement cm ³ /r [in ³ /r]	Dimensions mm [in]	
	X	Y
80 [4.9]	97 [3.82]	140.3 [5.52]
100 [6.1]	101.6 [4]	144.9 [5.7]
130 [7.9]	108.1 [4.26]	151.4 [5.96]
160 [9.8]	108.1 [4.26]	151.4 [5.96]
195 [11.9]	114.8 [4.52]	158.1 [6.22]
245 [15]	123.8 [4.87]	167.1 [6.58]
305 [18.6]	135.2 [5.32]	178.5 [7.03]
395 [24.1]	151.1 [5.95]	194.4 [7.65]

XL2 disc valve motor series

XL2 bearingless mount EMEA (AZ) dimensions

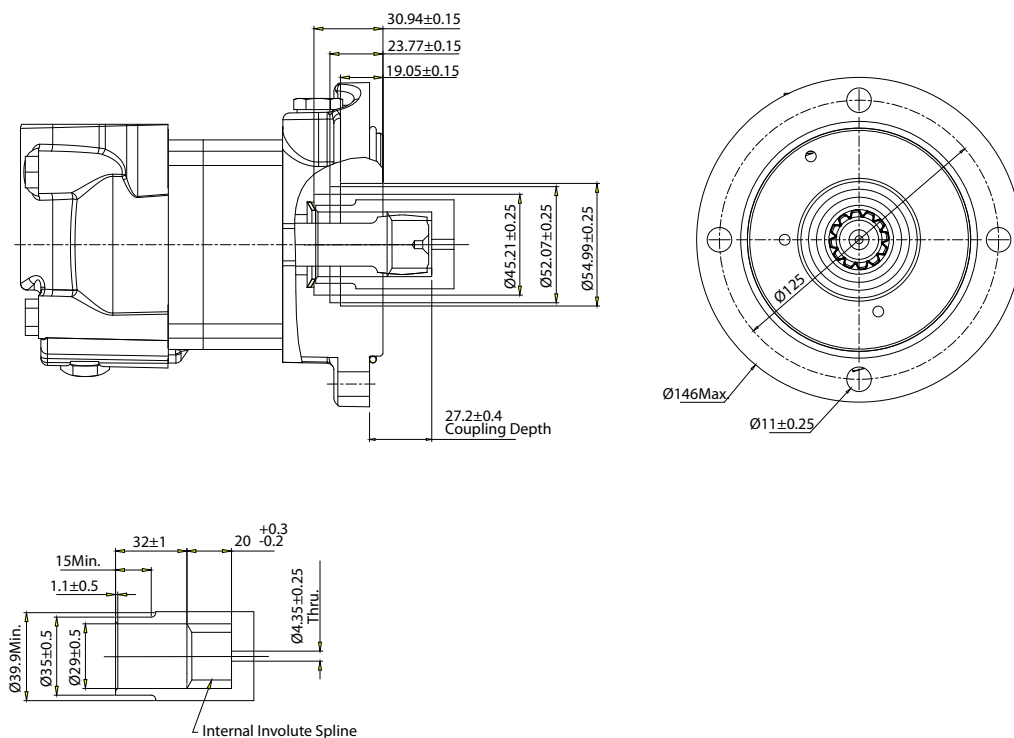

XL2 disc valve motor series

XL2 bearingless with integral valve dimensions

Standard rotation viewed from shaft end

- Port A pressurized - CW
- Port B pressurized - CCW

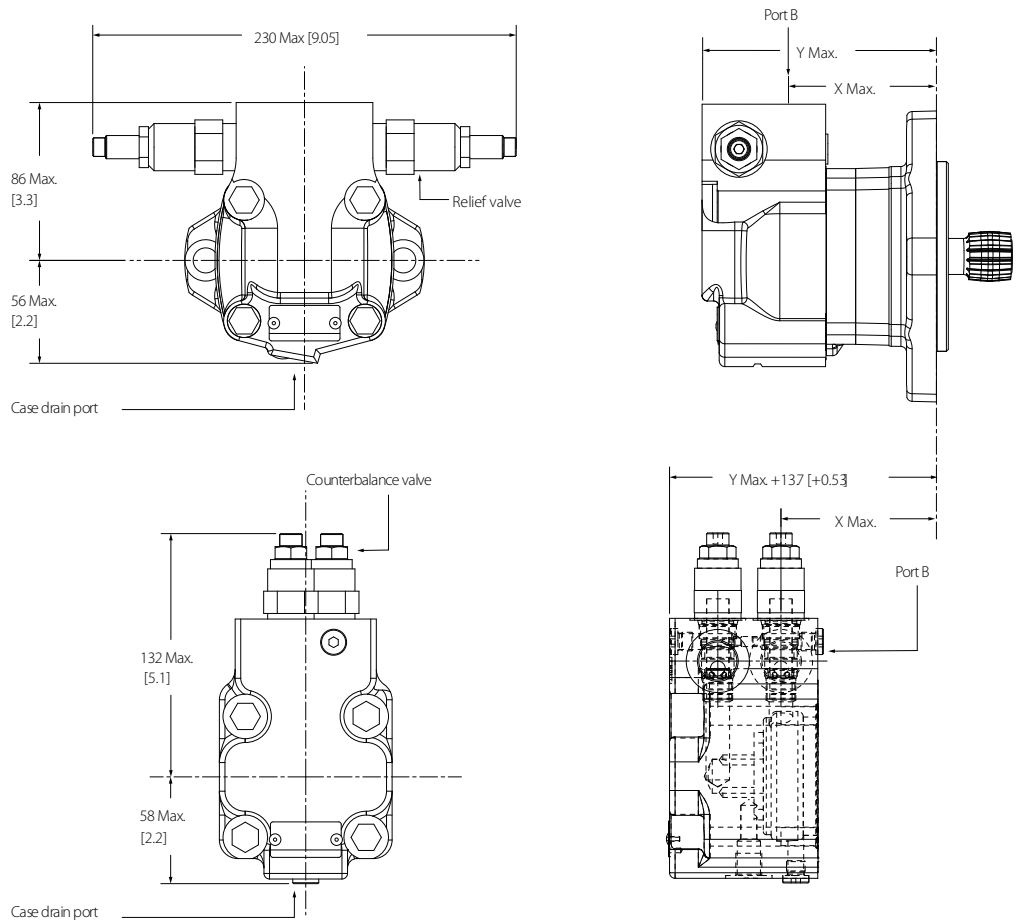

Dimensions

Displacement cm ³ /r [in ³ /r]	Dimensions mm [in]	
	X	Y
80 [4.9]	79 [3.11]	126.5 [4.98]
100 [6.1]	83.5 [3.29]	131.4 [5.17]
130 [7.9]	89.9 [3.54]	137.7 [5.42]
160 [9.8]	89.9 [3.54]	137.7 [5.42]
195 [11.9]	96.8 [3.81]	144.3 [5.68]
245 [15]	105.6 [4.16]	153.5 [6.04]
305 [18.6]	117.1 [4.61]	164.6 [6.48]
395 [24.1]	133.1 [5.24]	180.9 [7.12]
490 [29.9]	150.3 [5.92]	198.2 [7.8]

XL2 disc valve motor series

Relief valve and counterbalance valve schematics

Relief valve

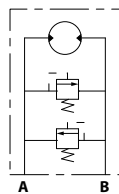

- RV3A-10-S -O-36
- CRV2-10-C-0-0-30

Counterbalance valve

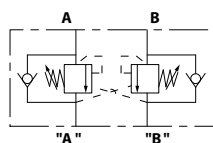

- 1CE30 (rated flow 30 l/min)

[Contact Danfoss for more detailed information about the relief valve and counterbalance valve.](#)

XL2 disc valve motor series

Bearingless motor installation information

- Internal spline in mating part to be per spline data. Specification material to be ASTM A304, 8620H vacuum degassed alloy steel carbonize to a hardness of 59-62 HRC with case depth (to 50HRC) of 0.076 -1.02 [0.030-0.040]. Dimensions apply after heat treat.
- Mating part to have critical dimensions as shown. Oil holes must be provided and open for proper oil circulation.
- Seal to be furnished with motor for proper oil circulation thru splines.
- Some means of maintaining clearance between shaft and mounting flange must be provided.
- Counterbore designed to adapt a standard sleeve bearing 35.010 -35.040 [1.3784 -1.3795] I.D. by 44.040 -44.070 [1.7339 -1.7350] O.D. (Oilite Bronze Sleeve Bearing AAM3544-22).

Bearingless motor installation dimensions

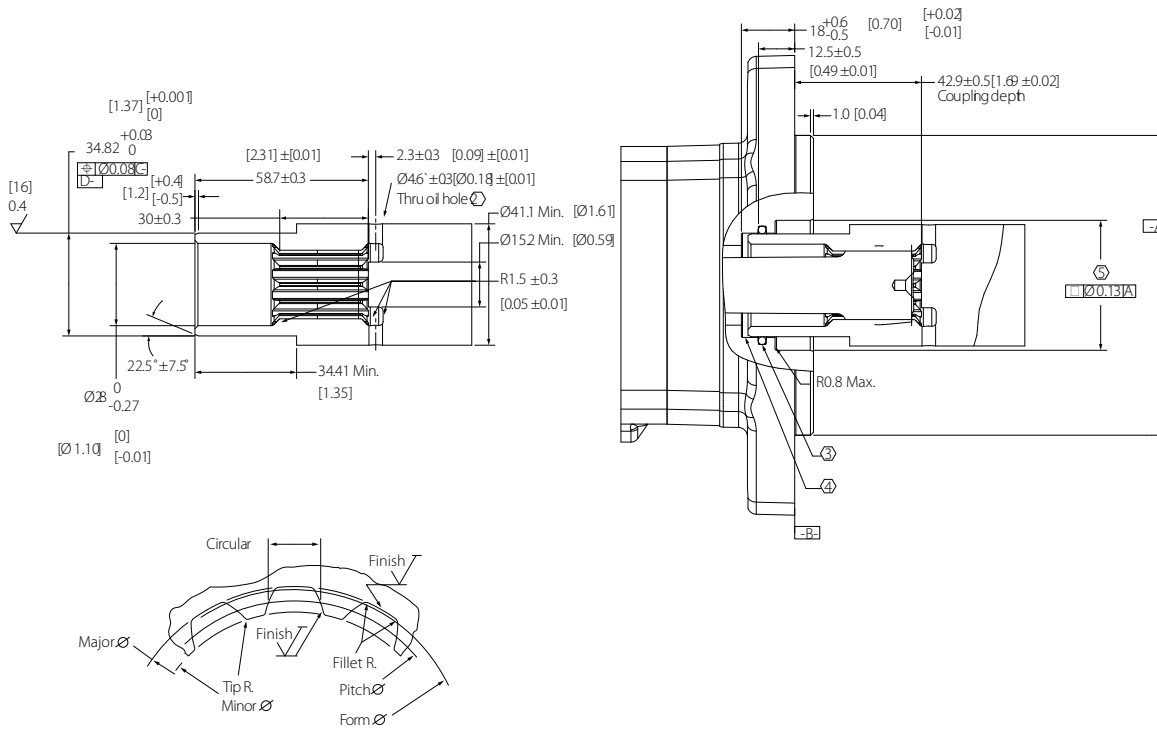

Installation information

Parameter	Data
Spline pitch	12/24
Pressure angle	30°
Number of teeth	12
Class of fit	Ref 5
Type of fit	Side
Pitch diameter	Ref. 25.400000 [1.0000000]
Base diameter	Ref. 21.997045 [0.8660254]
Major diameter	27.74 [1.092] max. 27.59 [1.086] min.
Minor diameter	23.097-23.224 [0.9093-0.9143]
Form diameter, min	29.93 [1.060]
Fillet radius	0.64-0.76 [0.0250-0.030]
Tip radius	0.25-0.38 [0.010-0.015]

XL2 disc valve motor series

Installation information (continued)

Parameter	Data
Finish	1.6 [63]
Involute profile variation	+0.000 -0.025 [+0.0000 -0.0010]
Total index variation	0.038 [0.0015]
Lead variation	0.013 [.0005]
Circular space width	Maximum actual: 4.318 [0.1700]
	Minimum effective: 4.216 [0.1660]
	Maximum effective: Ref. 4.270 [0.1681]
	Minimum actual: Ref. 4.247 [0.1672]
Dimension between two pins	Ref. 19.020-19.190 [0.7488-0.7555]
Pin diameter	4.496 [0.1770] Pins to Have 3.38 [0.133] Wide flat for root clearance

XL2 disc valve motor series

XL2 bearingless motor EMEA (AZ) installation information

- Internal spline in mating part to be per spline data. Specification material to be ASTM A304, 8620H vacuum degassed alloy steel carbonize to a hardness of 59-62 HRC with case depth (to 50HRC) of 0.076 -1.02 [0.030-0.040]. Dimensions apply after heat treat.
- Mating part to have critical dimensions as shown. Oil holes must be provided and open for proper oil circulation.
- Seal to be furnished with motor for proper oil circulation thru splines.
- Some means of maintaining clearance between shaft and mounting flange must be provided.
- Counterbore designed to adapt a standard sleeve bearing 35.010 -35.040 [1.3784 -1.3795] I.D. by 44.040 -44.070 [1.7339 -1.7350] O.D. (Oilite Bronze Sleeve Bearing AAM3544-22).

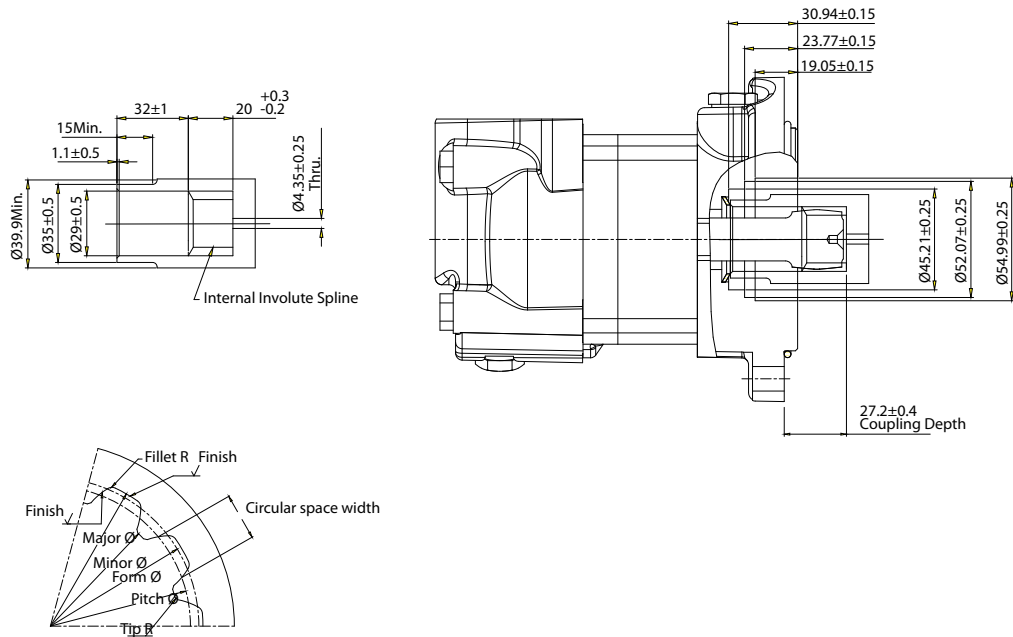

Installation information

Parameter	Data
Spline pitch	12/24
Pressure angle	30°
Number of teeth	12
Class of fit	Ref 5
Type of fit	Side
Pitch diameter	Ref. 25.400000 [1.0000000]
Base diameter	Ref. 21.997045 [0.8660254]
Major diameter	27.94 [1.1] max. 27.84 [1.096] min.
Minor diameter	23-23.033 [0.9055-0.9068]
Form diameter, min	27.69 [1.090]
Fillet radius	0.2-0.33 [0.00787-0.01299]
Tip radius	0.2-0.33 [0.00787-0.01299]

XL2 disc valve motor series

Installation information (continued)

Parameter	Data
Circular space width	Maximum actual: 4.328 [0.1704]
	Minimum effective: 4.247 [0.1672]
	Maximum effective: Ref. 4.277 [0.1684]
	Minimum actual: Ref. 4.288 [0.1688]
Dimension between two pins	Ref. 17.622-17.784 [0.6938-0.7002]
Pin diameter	4.8326-4.8346 [0.1903-0.19034]

XL2 disc valve motor series

Mounting dimensions

XL2 four bolt wheel mounting dimensions

Code AB

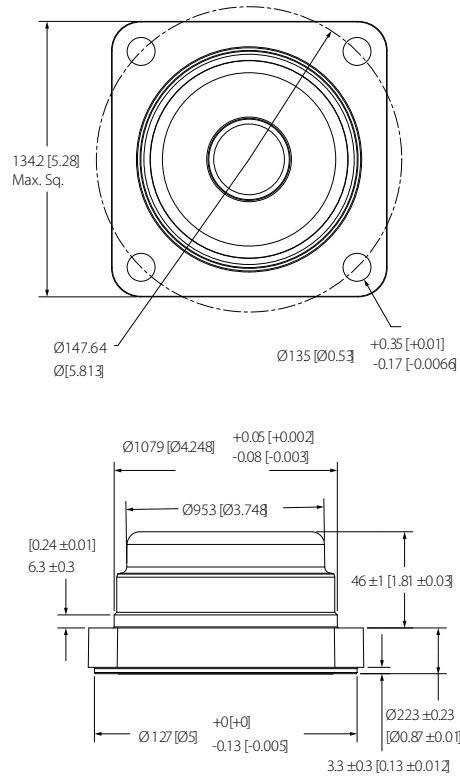

XL2 SAE A two bolt mounting dimensions

Code AC

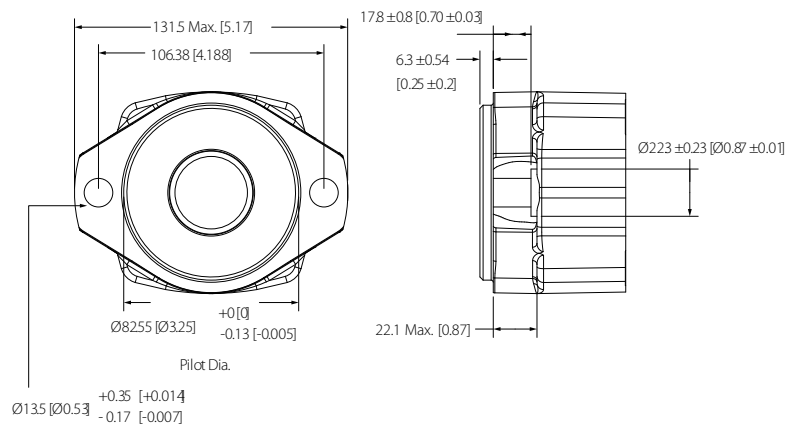

XL2 disc valve motor series

XL2 four bolt mounting dimensions

Code AH

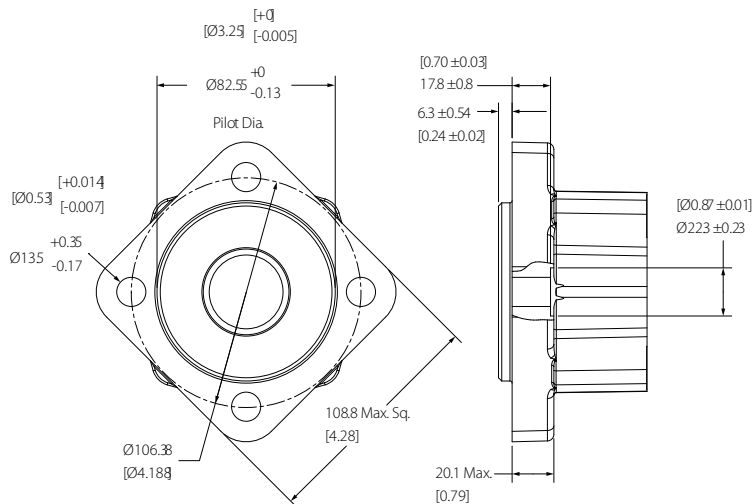

XL2 four bolt magneto mounting dimensions

Code AJ

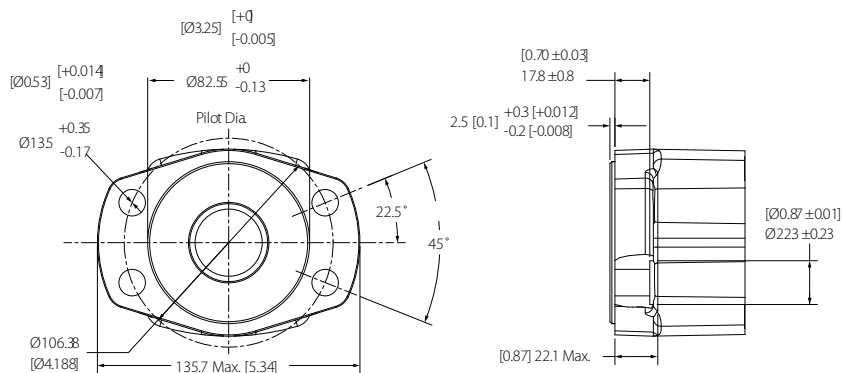

XL2 disc valve motor series

Shaft dimensions

XL2 shaft code 01 dimensions

25.4 [1] straight shaft (code 01)

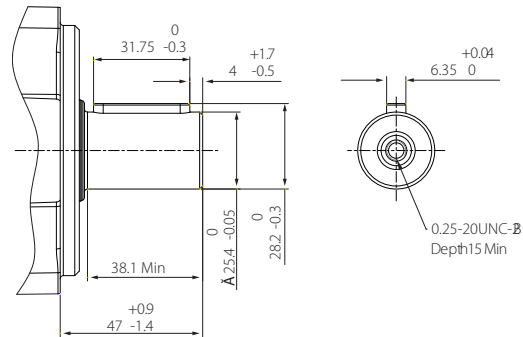

395 N·m [3500 in·lb] max. torque

XL2 shaft code 02 dimensions

31.75 [1.25] straight shaft (code 02)

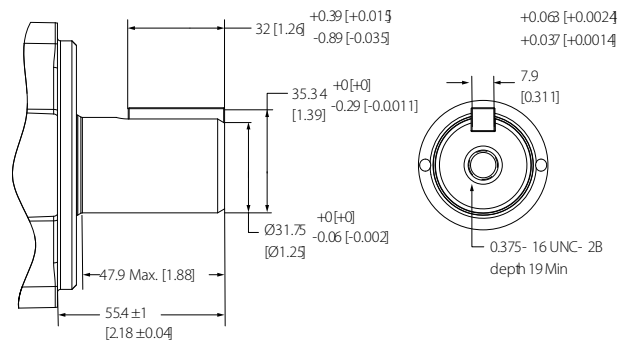

768 N·m [6800 in·lb] max. torque

XL2 disc valve motor series

XL2 shaft code 03 dimensions

31.75 [1.25] tapered shaft (code 03)

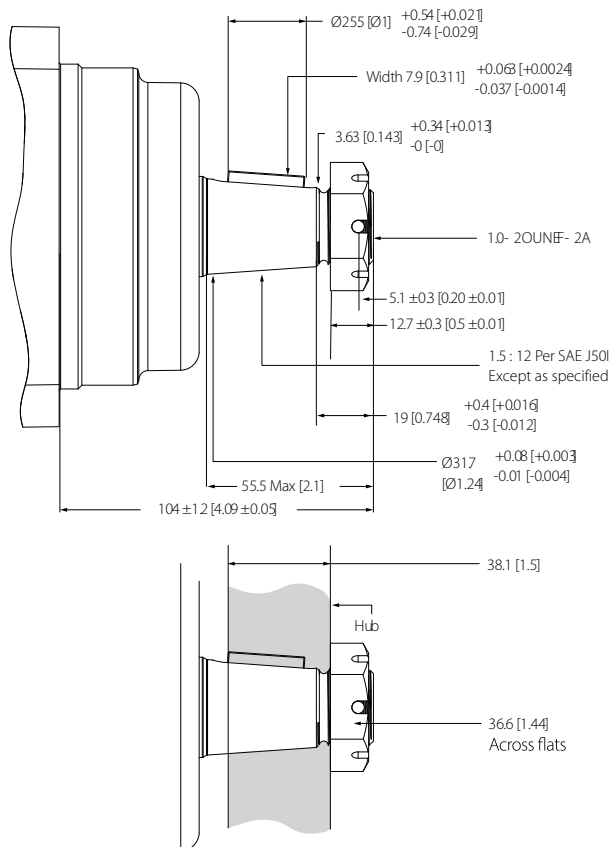

768 N-m [6800 in-lb] max. torque

Recommended torque on nut to align the slotted nut with the shaft crosshole:

- 373 N-m [275 lb-ft] dry
- 305 N-m [225 lb-ft] lub

XL2 shaft code 04 dimensions

31.75 [1.25] 14 tooth splined shaft (code 04)

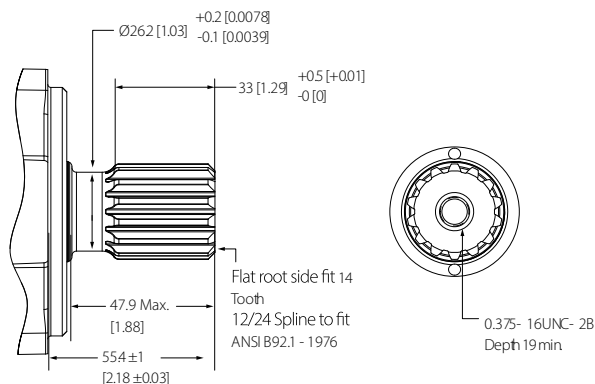

768 N-m [6800 in-lb] max. torque

XL2 disc valve motor series

XL2 shaft code 16 dimensions

32mm straight shaft (code 16)

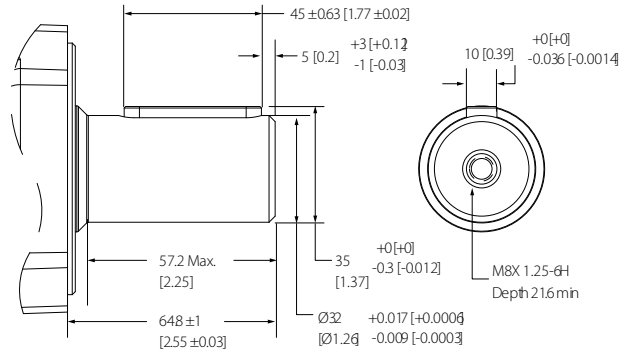

768 N·m [6800 in·lb] max. torque

XL2 shaft code 35 dimensions

SAE 6B splined shaft (code 35)

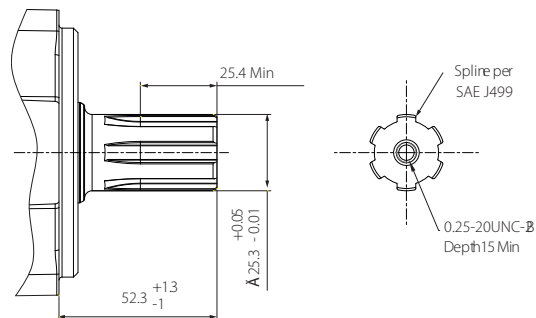

395 N·m [3500 in·lb] max. torque

XL2 shaft code 41 dimensions

35mm [1.38] tapered (code 41)

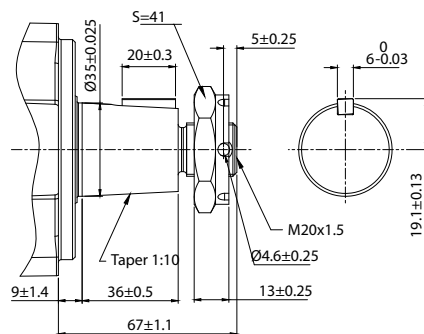

768 N·m [6800 lb·in] max. torque

XL2 disc valve motor series

XL2 shaft code 98 dimensions

25mm straight shaft (code 98)

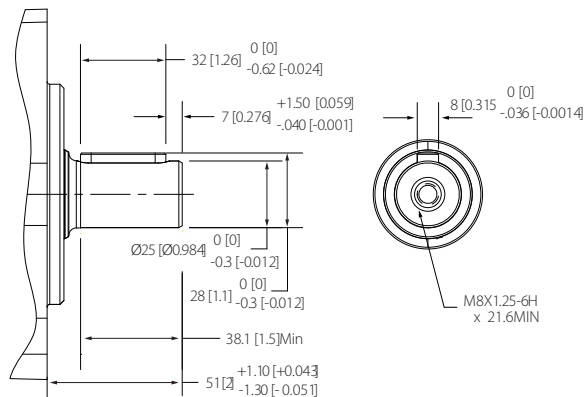

395 N·m [3500 in·lb] max. torque

XL2 shaft code 99 dimensions

31.75 [1.25] 14 tooth spline with extra length (code 99)

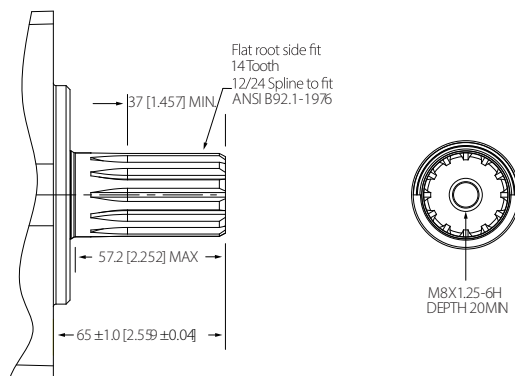

768 N·m [6800 in·lb] max. torque

XL2 disc valve motor series

Port dimensions

XL2 staggered ports AA, AG, 01, 02 dimensions

Dimensions

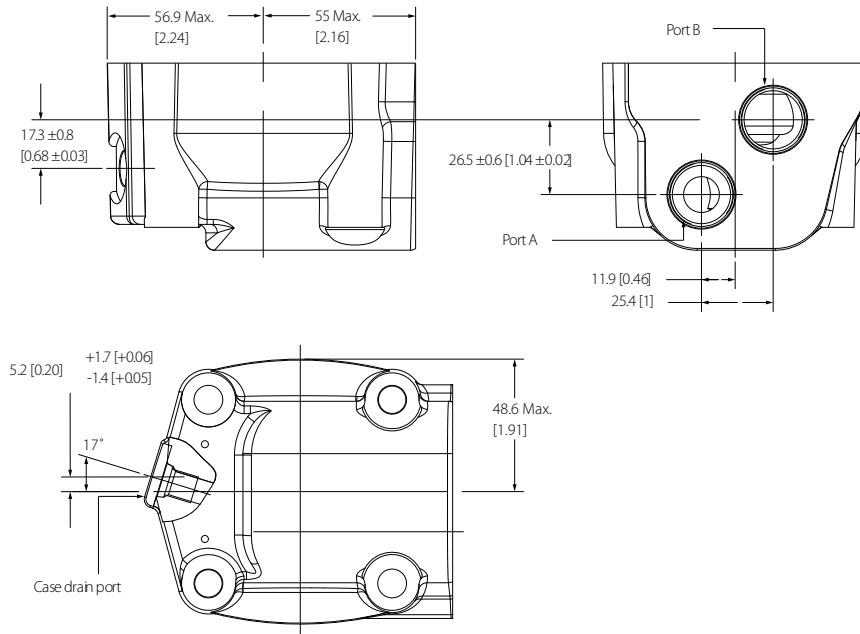

Port code numbers

Port	Code
Main ports (2) 7/8-14 UNF-2B SAE O-ring ports	AA
Main ports (2) G1/2 O-ring ports	AG
Case drain port (1) 7/16-20 UNF-2B SAE O-ring ports	01
Case drain port (1) G1/4 O-ring port	02

XL2 disc valve motor series

XL2 manifold port AE dimensions

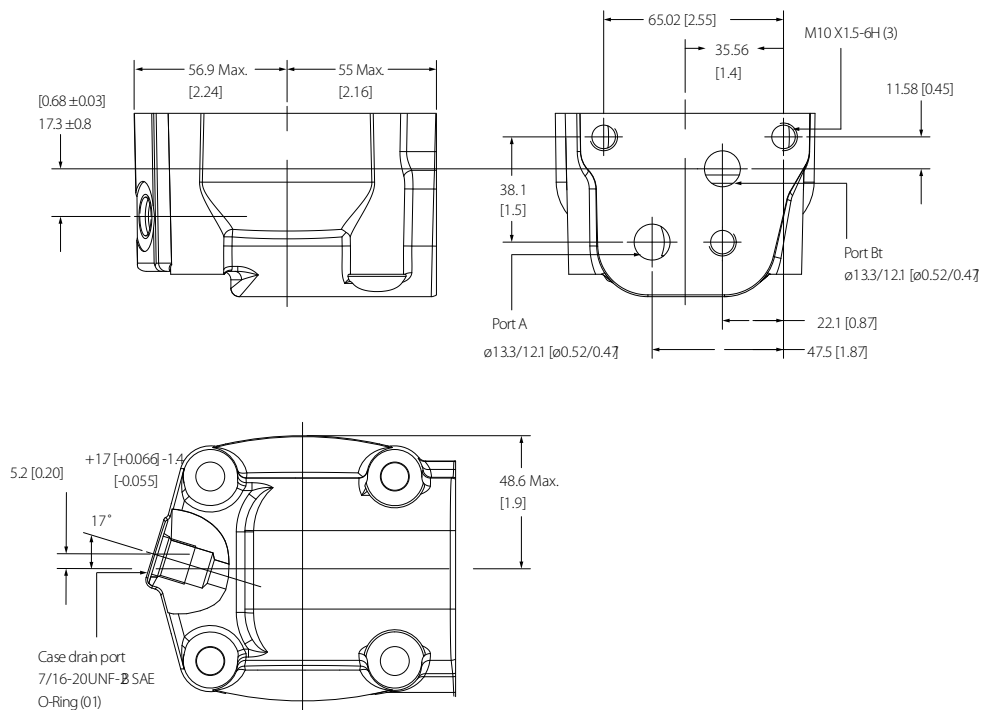

XL2 manifold ports AS, 02 dimensions

Dimensions

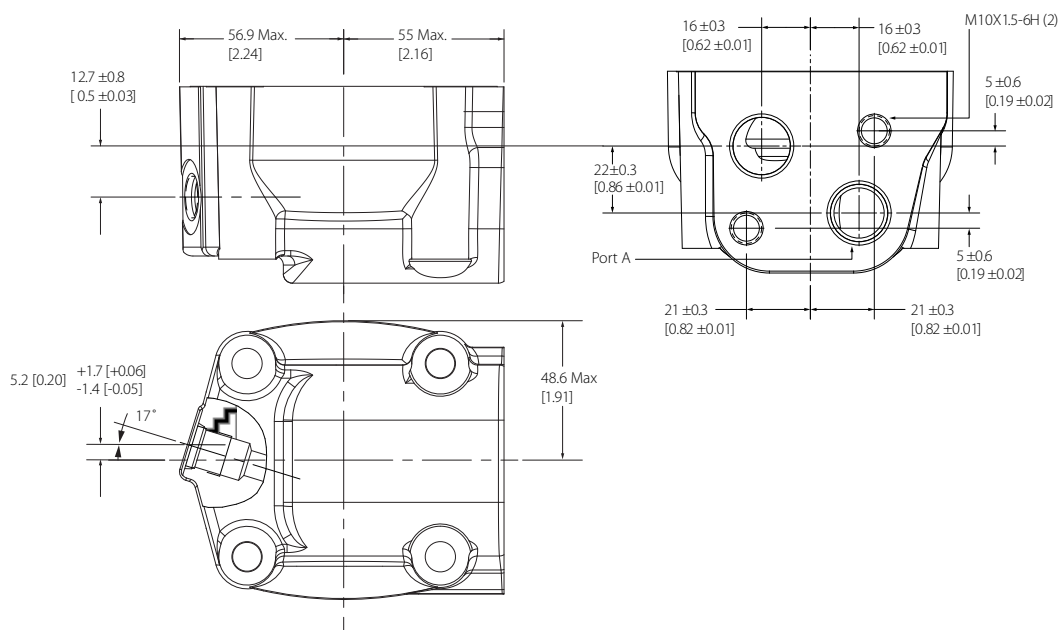

XL2 disc valve motor series

Port code numbers

Port	Code
G1/2 staggered port (2)	AS
G1/4 case drain port (1)	02

XL2 end port dimensions

Dimensions

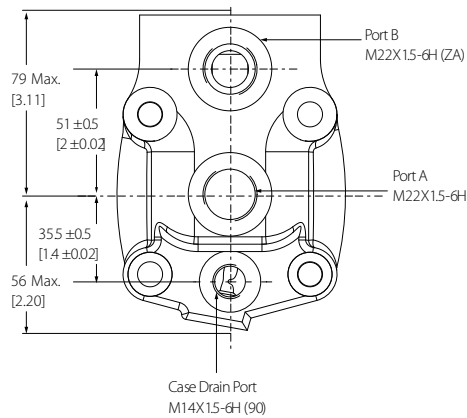

Port code numbers

Port	Code
Main ports (2) 22 x 1.5-6H end ports	ZA
Case drain port (1) M14 x 1.6-6H O-ring port	90

XL2 side ports dimensions

Dimensions

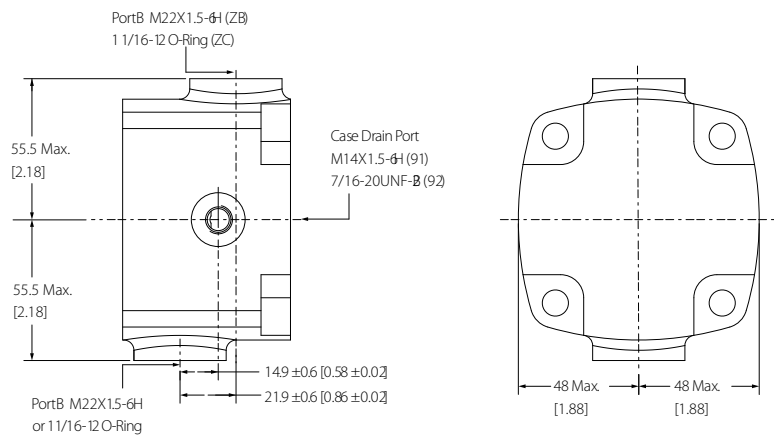

XL2 disc valve motor series

Ports code numbers

Port	Code
Main ports (2) M22x1.5-6H ports (positioned 180° apart)	ZB
M14x1.5-6H O-ring port	91

XL2 ports with relief valves dimensions

Dimensions

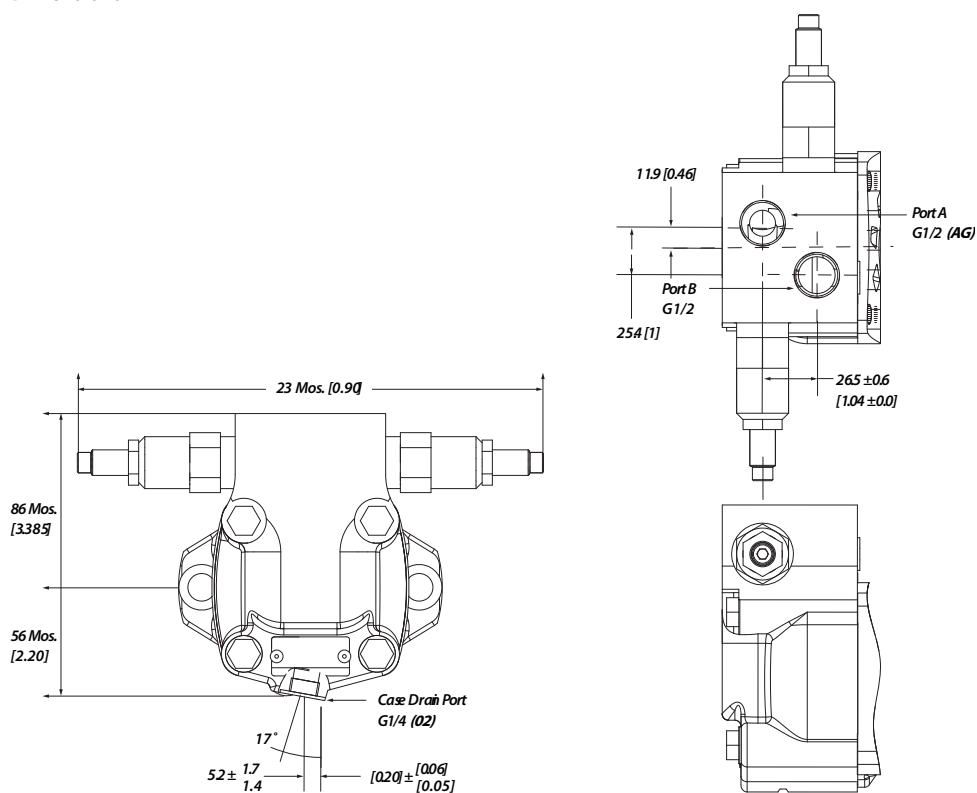

XL2 disc valve motor series

XL2 ports with counterbalance valve dimensions

Dimensions

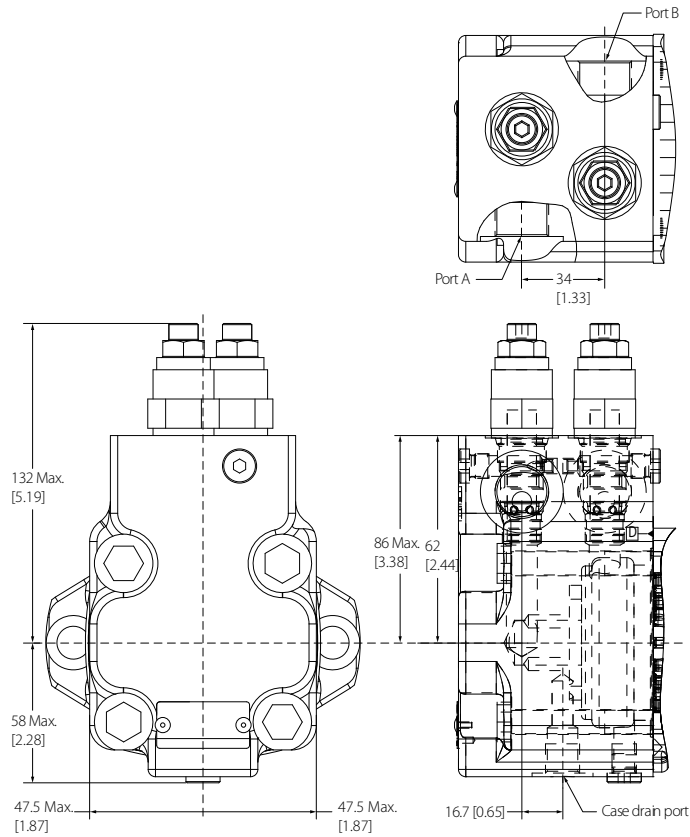

Ports code numbers

Port	Code
7/8-14UNF-2B SAE O-ring staggered ports (2)	AA
G1/2 staggered ports	AG
7/16-20UNF-2B SAE O-ring case drain Port (1)	01
G1/4 case drain port (1)	02

XL2 disc valve motor series

Shaft side load capacity

These curves indicate the radial load capacity on the motor shaft(s) at various locations with an allowable external thrust load of 454 kg [1000 lb].

Case pressure will increase the allowable inward thrust load and decrease the allowable outward thrust load. Case pressure will push outward on the shaft at 94 kg/7 bar [208 lb/100 psi].

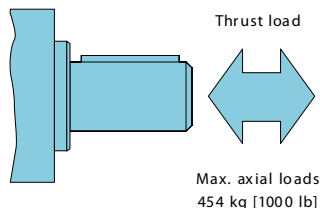

Each curve is based on a B10 bearing life of 2000 hours. The 12,000,000 revolution curve represents 100 RPM. The 3,000,000 revolution curve represents 25 RPM.

Standard motor straight and splined shafts

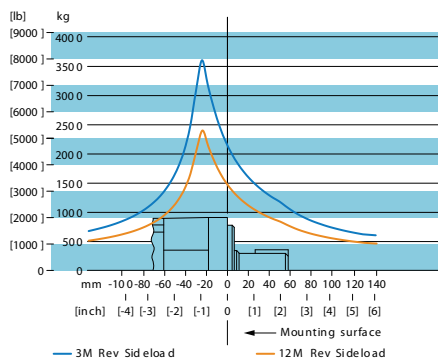

Wheel motor tapered shaft

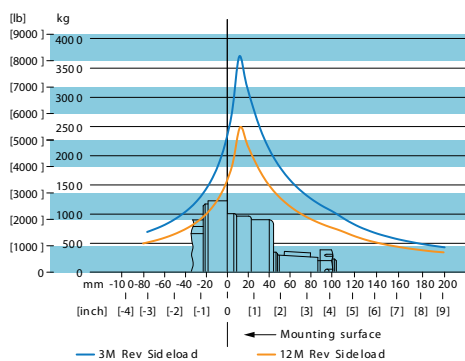

To determine radial load at speeds other than 25 RPM and 100 RPM, multiply the load values on the 12M revolution curve by the factors in the table below.

RPM	Multiplication factor
50	1.23
100	1.00
200	0.81
300	0.72
400	0.66
500	0.62
600	0.58

XL2 disc valve motor series

RPM	Multiplication factor
700	0.56
800	0.54

XL2 case pressure seal limitation

Xcel XL2 series case pressure seal limitation motors are durable and have long life as long as the recommended case pressure is not exceeded.

Allowable case pressure is highest at low shaft speeds. Consequently, motor life will be shortened if case pressure exceeds these ratings (acceptability may vary with application). Determine if an external case drain is required from the case pressure seal limitation chart.

Case porting advantage contamination control Flushing motor case

Cooler motor Exiting oil draws motor heat away

Extended motor seal life Maintain low case pressure with a preset restriction in the case drain line

Standard shaft seal

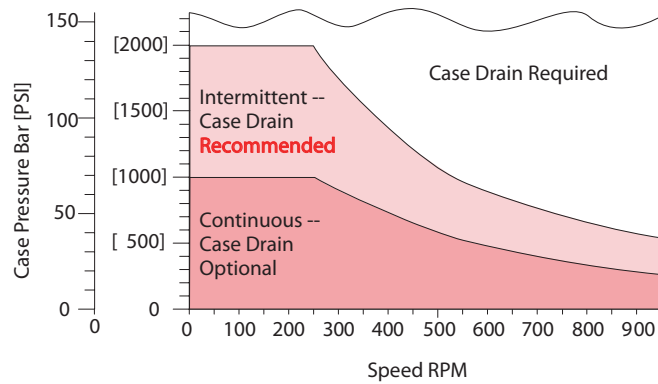

High pressure shaft seal

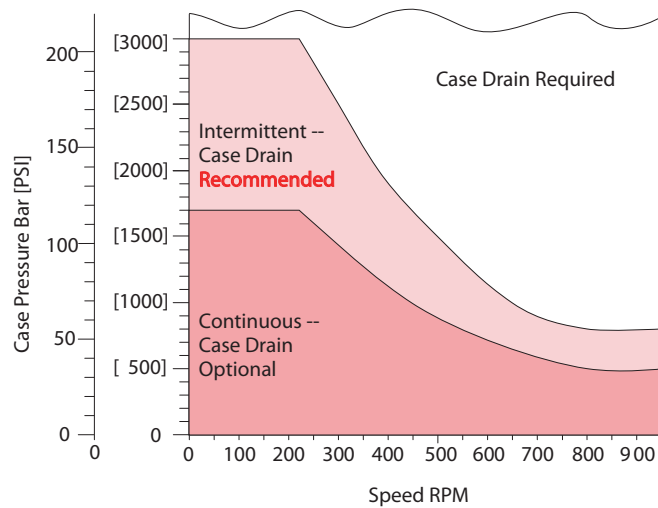

XL2 disc valve motor series

XL2 model code

Model code identification

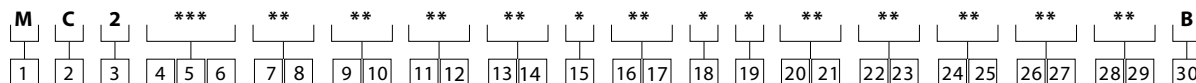

XL2 product, series, displacement options

1 - product

Code	Description
M	Motor

2, 3 - series

Code	Description
C2	Xcel XL2 series

4, 5, 6 - displacement

Code	Description
80	80.6 [4.92]
100	101.6 [6.20]
130	130.6 [7.97]
160	158.1 [9.65]
195	194.8 [11.89]
245	244.3 [14.91]
305	306.6 [18.71]
395	393.8 [24.03]
490	489.0 [29.8]

XL2 mounting flange and output shaft options

7, 8 - mounting flange

Code	Description
AB	Wheel, 4 bolt: 108.0 [4.25] pilot dia. 13.59 [0.535] dia. holes on 147.6 [5.81] dia. bolt circle. 127.0 [5.00] dia. rear mount pilot.
AC	Standard, 2 bolt: 82.6 [3.25] pilot dia. 13.59 [0.535] dia. holes on 106.4 [4.19] dia. bolt circle. SAE A.
AH	Standard, 4 bolt: 82.6 [3.25] pilot dia. 13.59 [0.535] dia. holes on 106.4 [4.19] dia. bolt circle.
AJ	Standard (magneto), 4 bolt: 82.6 [3.25] pilot dia. 13.59 [0.535] dia. holes on 106.4 [4.19] dia. bolt circle. 2.79 [0.110] pilot length.
AZ	Bearingless - European (w/o leakage slots), 4 bolt: 100.0 [3.94] pilot dia. 11.0 [0.43] dia. holes on 125.0 [4.92] dia. bolt circle.

9, 10 - output shaft

Code	Description
01	25.4 [1.000] dia. straight shaft with 0.250-20 UNC-2B hole in shaft end, woodruff key
02	31.75 [1.250] dia. straight shaft with 0.375 -16 UNC-2b thread in end, 7.938 [0.3125] Sq. x 31.75 [1.250] straight key

XL2 disc valve motor series

9, 10 - output shaft (continued)

Code	Description
03	31.75 [1.250] dia. 0.125:1 tapered shaft per SAE J501 with 1.000-20 UNEF-2A threaded shaft end and slotted hex nut, 7.938 [0.3125] sq. x 25.40 [1.000] straight key
04	31.75 [1.250] dia. flat root side fit, 14 tooth, 12/24 dp 30 deg. involute spline with 0.375-16UNC-2B thread in end, 33.0 [1.30] minimum full spline length
16	32.00 [1.260] dia. straight shaft with M8 x 1.25-6H thread in end, 9.982 [.3930] W x 7.995 [0.3132] H x 45.00 [1.772] L key
35	25.40 [1.000] dia. 6B spline per SAE J 499 with 0.250-20 UNC-2B thread in end, 25.40 [1.000] minimum full spline length
39	None (bearingless) European spline
41	35.00 [1.378] dia. 1:10 tapered shaft per ISO R775 with M20x1.5-6g thread shaft end and slot hex nut, 6.00 [0.236] sq x 20.0 [0.787] key
98	25.00 [0.984] dia. straight shaft with M8 x 1.25-6H thread in end, 7.982 [0.3142] W x 6.954 [0.2738] H x 32 [1.260] L key
99	31.75 [1.250] dia. flat root side fit, 14 tooth, 12/24 DP 30 deg. involute spline with M8 x 1.25-6H thread in end, 37.0 [1.46] minimum full spline length, 139 [5.471] oal shaft length

XL2 ports, case flow, relief valve, geroler options

11, 12 - port description

Code	Description
AA	7/8-14UNF-2B SAE O-ring ports - staggered ports
AE	13.0 [0.512] dia. manifold ports with 3 x M10 x 1.5-6H port block mounting holes
AG	G 1/2 B SP straight THD ports - staggered ports
AS	G 1/2 B SP straight THD ports - staggered port with 2 x M10 x 1.5-6H port block mounting holes - European
BA	M22 x 1.5-6H ports per ISO9974-1 - staggered ports
ZA	M22 x 1.5-6H ports per ISO9974-1- end ports
ZB	M22 x 1.5-6H ports per ISO9974-1- side ports (position 180° apart)
ZC	1 1/16-12 O-ring ports -side ports (position 180° apart)

13, 14 - case flow

Code	Description
00	None
01	7/16-20UNF-2B SAE O-ring port
02	G 1/4 B SP straight THD port
10	G 1/4 B S P straight THD port with optional G 1/4 B SP straight THD port in mounting flange
90	M14X 1 .5-6H ports per ISO9974-1- end ports
91	M14X 1 .5-6H ports per ISO9974-1- side ports (Position 180° apart)
92	7/16-20 O-ring ports -side ports (position 180° apart)

15 - low pressure relief

Code	Description
0	None

XL2 disc valve motor series

16, 17 - pressure/flow setting

Code	Description
00	None
17	Relief valve set @ 170.0 bar [2465 lbf/in ²]

18 - geroler

Code	Description
1	Standard

XL2 shaft seal, accessories, special feature options

19 - shaft seal

Code	Description
0	Standard
3	High pressure shaft seal
4	Seal guard
6	High pressure shaft seal, seal guard

20, 21 - accessories

Code	Description
00	None
AE	M12 threaded connector, long body digital speed and direction pickup, two 30 pulse signals in quadrature per revolution: <ul style="list-style-type: none"> • pin 1 = power supply • pin 2 = output signal 1 • pin 3 = common • pin 4 = output signal 2 Supply voltage: 8 to 28 VDC output voltage low: 0.5 V DC max at 10 mA.

22, 23 - special features (hardware)

Code	Description
00	None (standard)
52	Drain outtake through spacer plate

24, 25 - special features (assembly)

Code	Description
00	None (standard)
AA	Flange rotated 90°
AB	Reverse rotation
AC	Flange rotated 90° reverse rotation

XL2 paint, identification, design code

26, 27 - paint/packaging

Code	Description
AA	Blue
AB	Black

XL2 disc valve motor series

28, 29 - customer identification or nameplate

Code	Description
AA	Standard

30 - design code

Code	Description
B	Second

[For additional special feature options, contact your Danfoss representative.](#)

XL4 disc valve motor series

About the XL4 series

Danfoss' Xcel™ series low speed high torque disc valve motors offer the most popular features and options from the parallel Danfoss Char-Lynn range and are optimized to bring the highest value in medium duty applications.



XL4 features, benefits, applications

Features

- 6 displacements, a variety of mounting flanges and output shafts
- Reliable, proven design
- High efficiency

Benefits

- Flexibility in designing this motor into a system
- Options that fit well into tough applications

Applications

- Mowers
- Snow Removal
- Sprayers
- Trenching machines
- Wood Processing Machines

XL4 disc valve motor series

XL4 specifications overview

Specification	Data
Geroler element	6 displacements
Flow l/min [US gal/min]	95 [25] continuous 150 [40] intermittent
Speed RPM	582 continuous 693 intermittent
Pressure bar [psi]	205 [3000] continuous 310 [4500] intermittent
Torque N·m [lb·in]	945 [8400] continuous 1170 [10350] intermittent

Continuous motor may run continuously at the listed ratings

Intermittent 10% of every minute

XL4 disc valve motor series

XL4 part identification

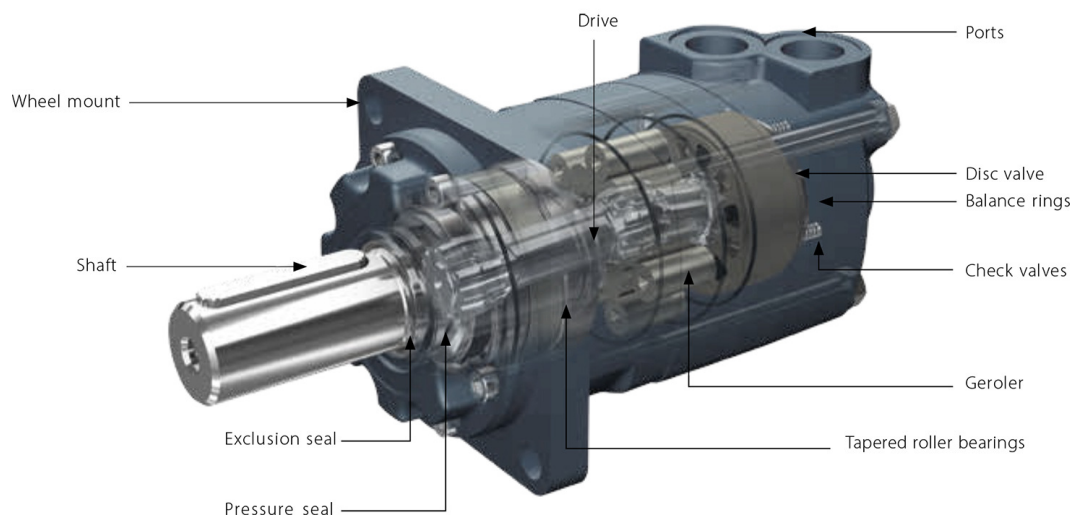

XL4 technical data

XL4 160cc-490cc technical data

Displacement cm³/r [in³/r]		160 [9.8]	205 [12.5]	245 [15.0]	310 [19.0]	395 [24.0]	495 [30]
Flow l/min [US gal/min]	Continuous	95 [25]	95 [25]	95 [25]	95 [25]	95 [25]	95 [25]
	Intermittent	115 [30]	115 [30]	130 [35]	130 [35]	150 [40]	150 [40]
Max speed RPM	Continuous	582	459	383	303	239	191
	Intermittent	693	546	532	422	376	305
Pressure Δ bar [Δ psi]	Continuous	205 [2973]	205 [2973]	205 [2973]	205 [2973]	190 [2750]	140 [2000]
	Intermittent	310 [4500]	310 [4500]	310 [4500]	260 [3750]	240 [3500]	170 [2500]
Torque N·m [lb·in]	Continuous	485 [4292]	600 [5310]	705 [6239]	850 [7523]	930 [8240]	945 [8375]
	Intermittent	705 [6239]	800 [7080]	845 [7478]	1065 [9425]	1185 [10470]	1170 [10350]
Weight kg [lbs]	Standard or wheel mount	18.1 [39.9]	18.4 [40.6]	18.6 [41]	19.5 [43]	20.4 [45]	21.8 [48.1]
	Bearingless	14.1 [31.1]	14.5 [32]	14.7 [32.4]	15.6 [34.4]	16.6 [36.6]	17.9 [39.5]

For maximum case pressure, see case pressure seal limitation graph.

Δ bar [psi] The true pressure difference between inlet port and outlet port.



Continuous rating Motor may be run continuously at these ratings.

Intermittent operation 10% of every minute.

To ensure best motor life, run motor for approximately 1 hour at 30% of rated pressure before application to full load. Be sure motor is filled with fluid prior to any load applications.

XL4 disc valve motor series

Recommended operating parameters

Data	Recommended
Max. inlet pressure	310 bar [4500 psi]  Caution <hr/> Do not exceed Δ pressure rating
Max. return pressure	310 bar [4500 psi] with case drain line installed  Caution <hr/> Do not exceed Δ pressure rating
Fluids	Premium quality, anti-wear type hydraulic oil with a viscosity of no less than 13 cSt [70 SUS] at operating temperature.
Operating temperature	-34 to 82 °C [-30 to 180 °F]
Filtration	Per ISO cleanliness code 4406:20/18/13

XL4 disc valve motor series

XL4 performance data

Performance data is typical at 25 cSt (120 SUS). Actual data may vary slightly from unit to unit in production.

XL4 160cc motor

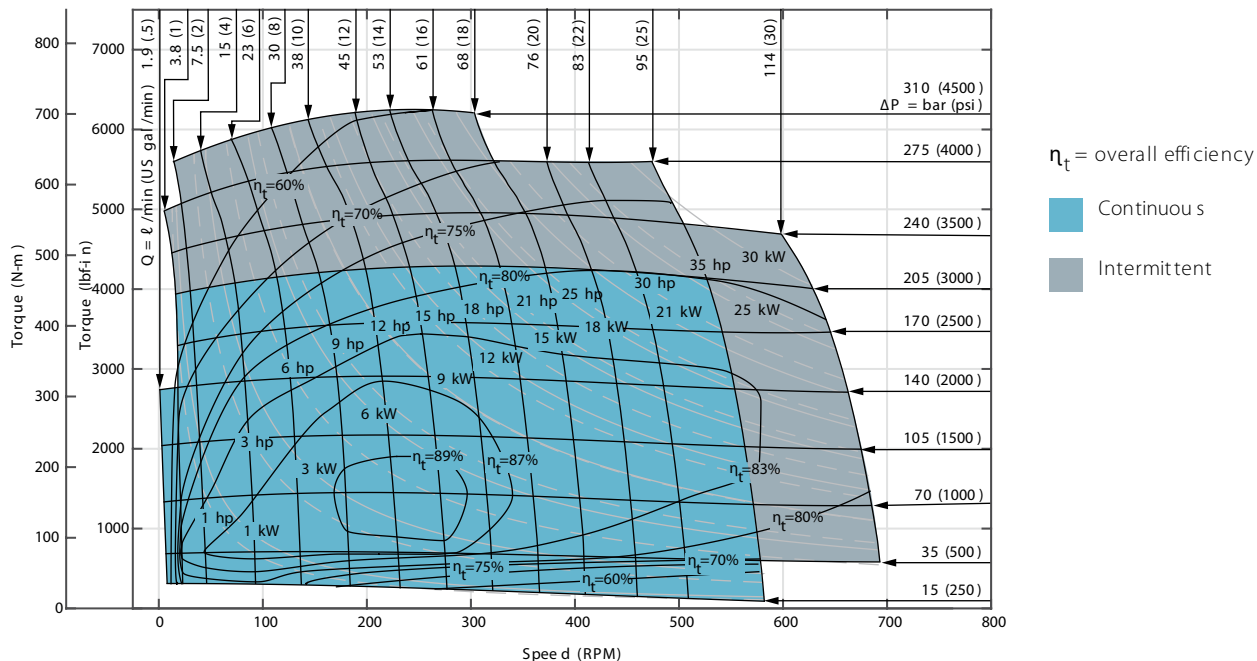

XL4 205cc motor

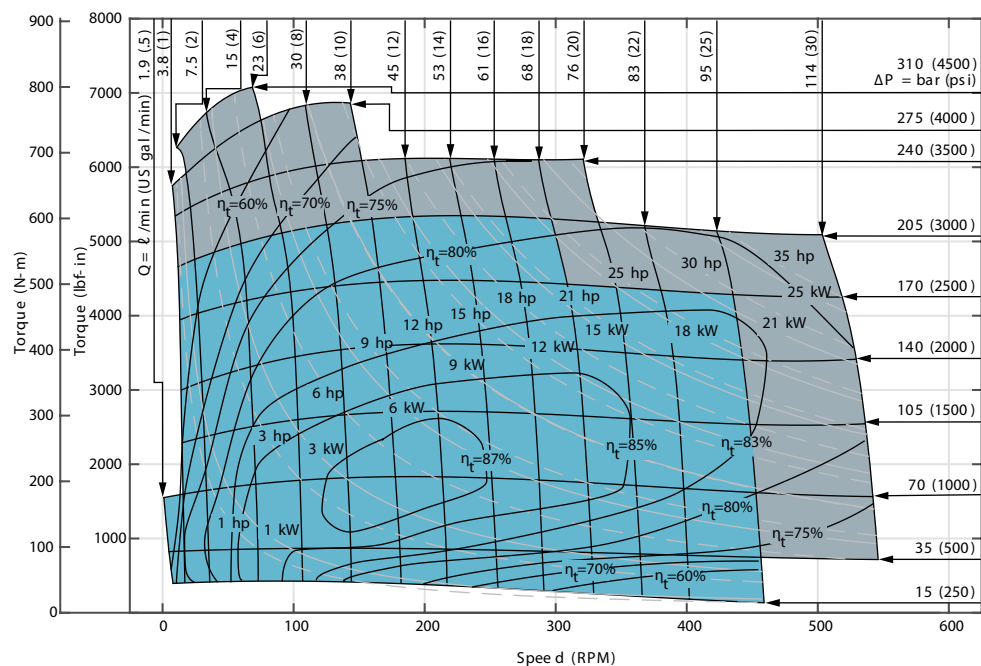

XL4 disc valve motor series

XL4 245cc motor

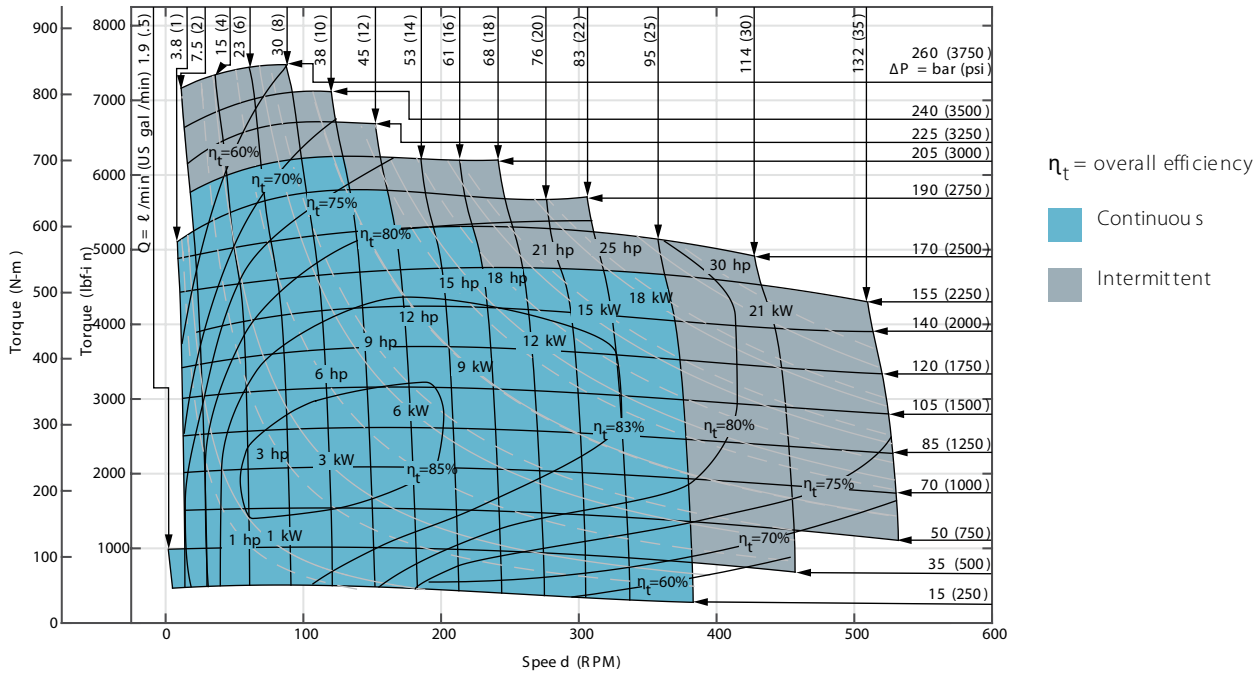

XL4 310cc motor

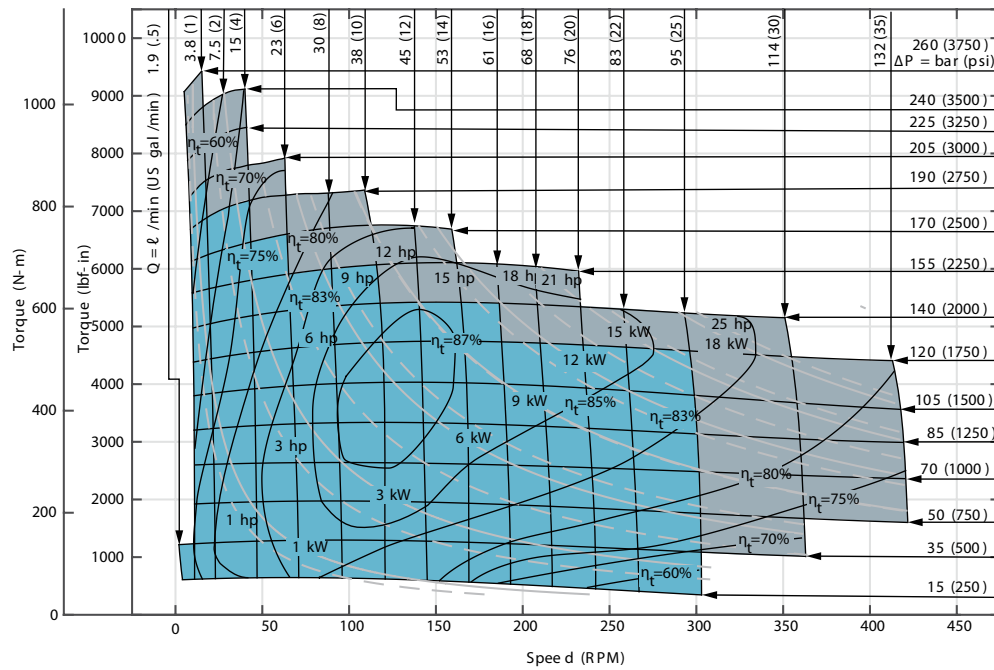

XL4 disc valve motor series

XL4 395cc motor

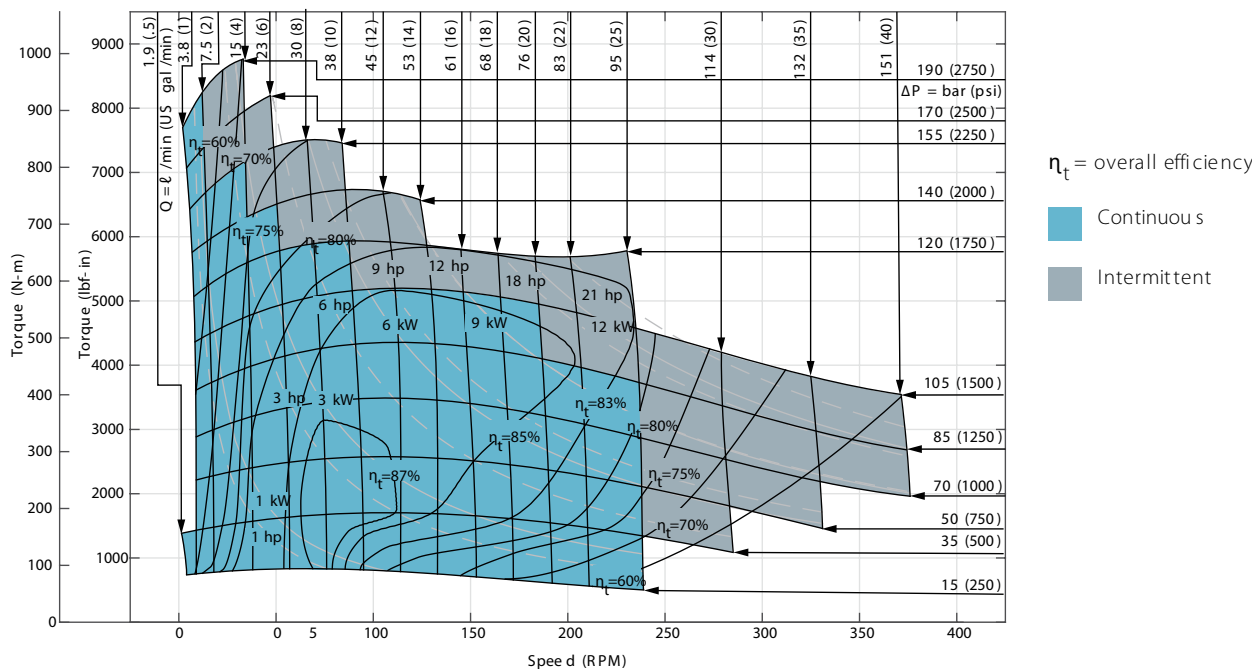

XL4 495cc motor

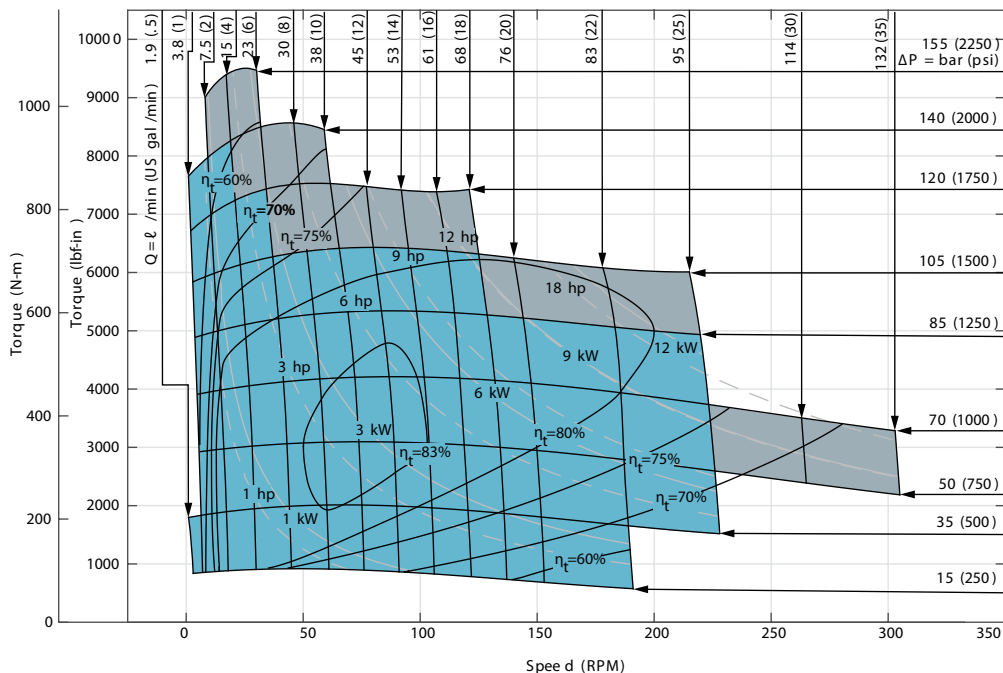

XL4 disc valve motor series

Mounting dimensions

XL4 standard and wheel mount dimensions

Standard rotation viewed from shaft end

- Port A pressurized - CW
- Port B pressurized - CCW
- XL4 standard shaft seal and section seal kit number: Z331-32

Standard mount (code AB)

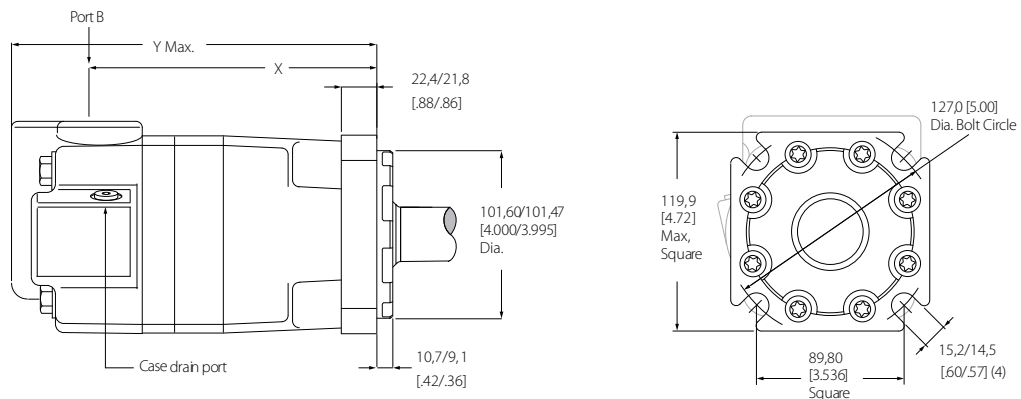

XL4 SAE C flange dimensions

SAE C flange (code AC)

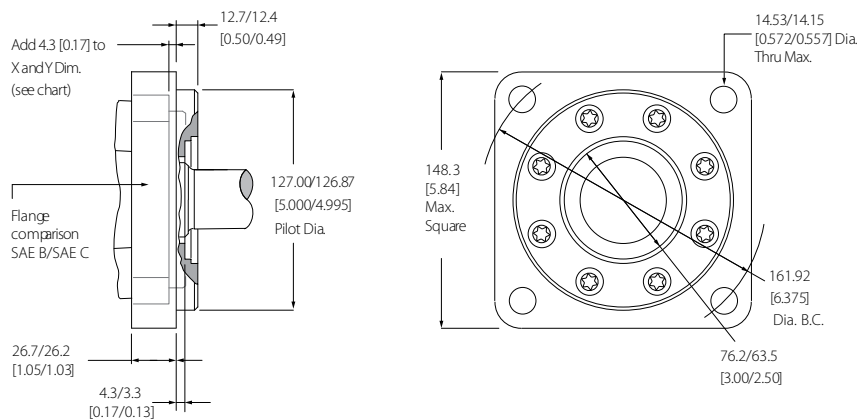

Standard mount motor dimensions

Displacement cm ³ /r [in ³ /r]	Dimensions in mm [in]	
	X	Y
160 [9.9]	168.7 [6.64]	224.7 [8.85]
205 [12.5]	177.2 [6.98]	233.2 [9.18]
245 [15.0]	168.7 [6.64]	224.7 [8.85]
310 [19.0]	177.2 [6.68]	233.2 [9.18]
395 [24.0]	187.9 [7.40]	243.9 [9.60]
495 [30.0]	200.7 [7.90]	256.8 [10.11]

XL4 disc valve motor series

XL4 ISO 125 B4HW flange dimensions

Standard rotation viewed from shaft end

- Port A pressurized - CW
- Port B pressurized - CCW

ISO 125 B4HW flange (code AD)

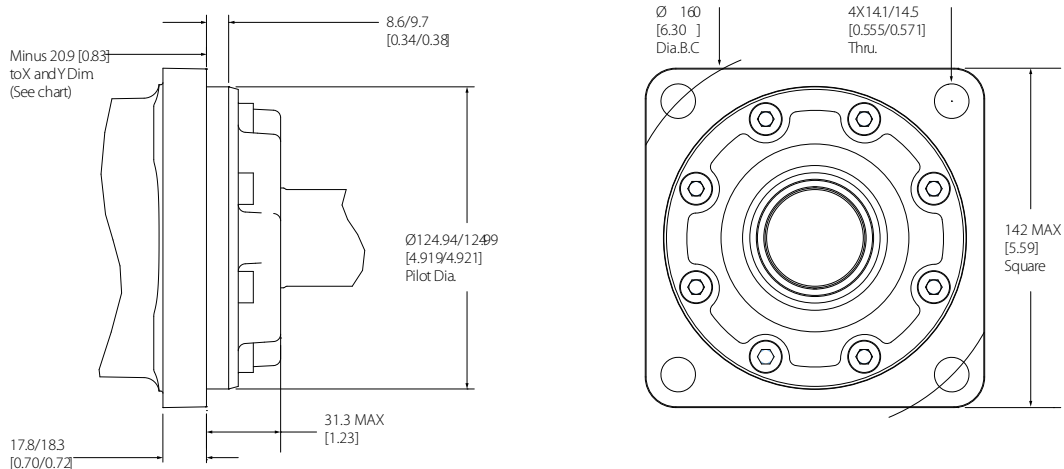

Dimensions

Displacement cm ³ /r [in ³ /r]	Dimensions in mm [in]	
	X	Y
160 [9.9]	168.7 [6.64]	224.7 [8.85]
205 [12.5]	177.2 [6.98]	233.2 [9.18]
245 [15.0]	168.7 [6.64]	224.7 [8.85]
310 [19.0]	177.2 [6.68]	233.2 [9.18]
395 [24.0]	187.9 [7.40]	243.9 [9.60]
495 [30.0]	200.7 [7.90]	256.8 [10.11]

XL4 disc valve motor series

XL4 bearingless mount dimensions

Standard rotation viewed from shaft end

- Port A pressurized - CW
- Port B pressurized - CCW

Bearingless mount (code AA)

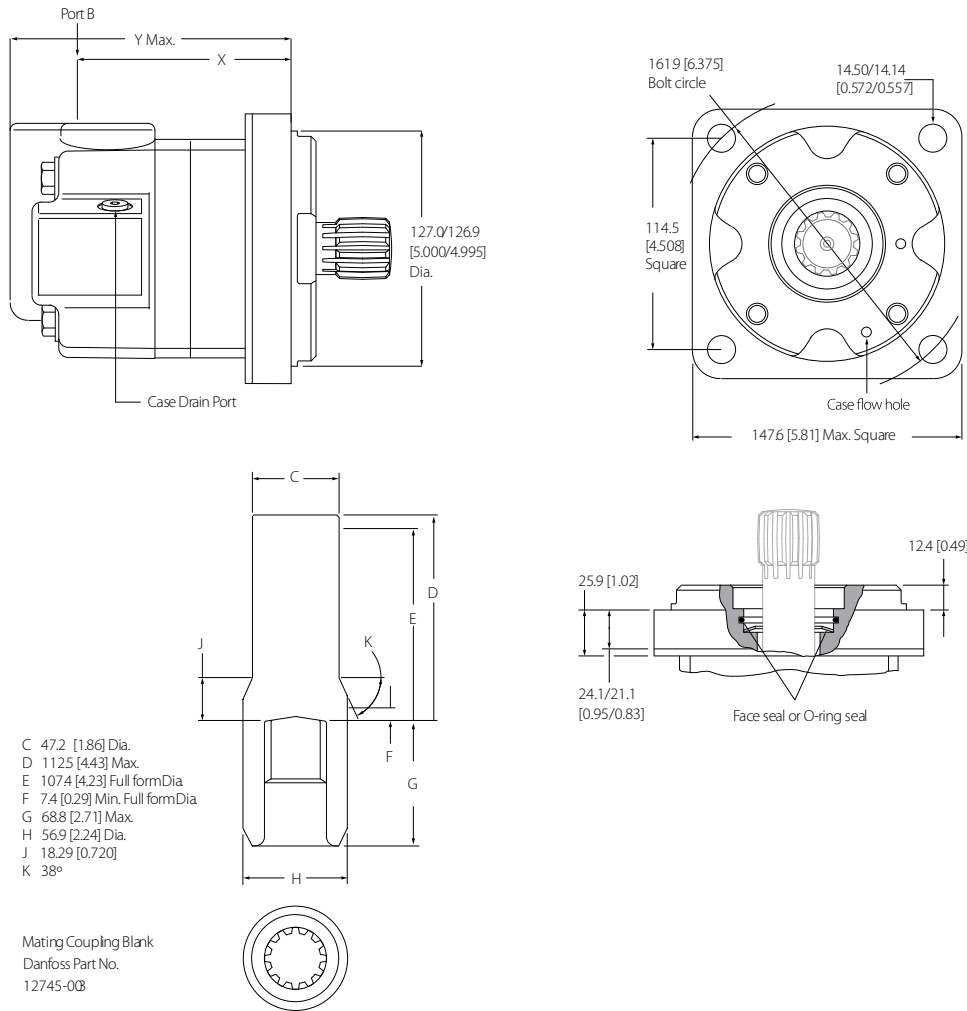

Dimensions

Displacement cm ³ /r [in ³ /r]	Dimensions in mm [in]	
	X	Y
160 [9.9]	101.4 [4.00]	157.1 [6.19]
205 [12.5]	109.9 [4.33]	165.7 [6.52]
245 [15.0]	101.4 [4.00]	157.1 [6.19]
310 [19.0]	109.9 [4.33]	165.7 [6.52]
395 [24.0]	120.6 [4.75]	176.3 [6.94]
495 [30.0]	133.5 [5.26]	189.2 [7.45]

For Xcel XL4 Series bearingless motor application information contact your Danfoss representative.
 Mating coupling blanks are available from Danfoss.

After machining blank, part must be hardened per Danfoss specification.

XL4 disc valve motor series

XL4 bearingless motor installation information

- Internal spline in mating part to be as follows: Material to be ASTM A304, 8620H. Carbonize to a hardness of 60-64 HRC with case depth (to 50HRC) of 0.076 - 1.27 [0.030 - 0.050] (dimensions apply after heat treat).
- Mating part to have critical dimensions as shown. Oil holes must be provided and open for proper oil circulation.
- Seal to be furnished with motor for proper oil circulation thru splines.
- Some means of maintaining clearance between shaft and mounting flange must be provided.
- Counterbore designed to adapt to a standard sleeve bearing 50.010 - 50.040 [1.9689 - 1.9700] ID by 60.050 - 60.080 [2.3642 - 2.3653] (Oilite bronze sleeve bearing).
- Similar to SAE C four bolt flange.
- 52.8 [2.08] M ax . dimension to be maintained when assembling shipping and installing unit to insure valve drive engagement with valve.

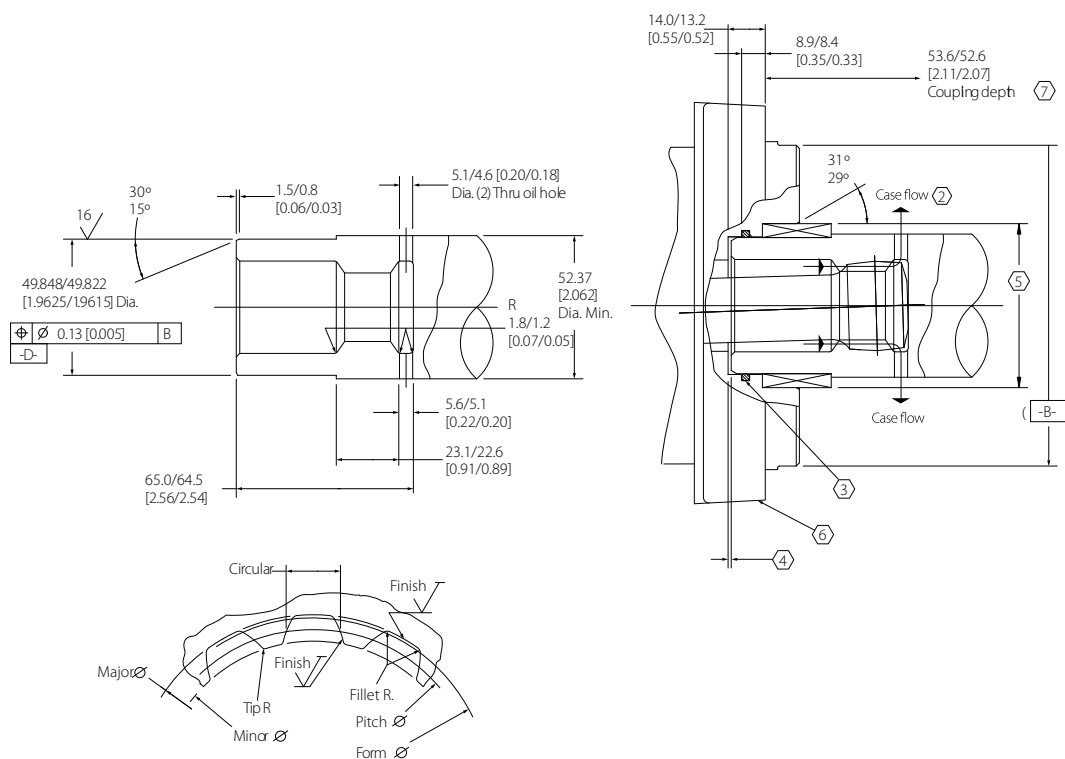

Installation information

Specification	Data
Spline pitch	10/20
Pressure angle	30°
Number of teeth	12
Class of fit	Ref. 5
Type of fit	Side
Pitch diameter	Ref. 30.480000 [1.2000000] 0,0 [0.008] D
Base diameter	Ref. 26.396455 [1.0392305]
Major diameter	33.43 [1.316] Max. 33.23 [1.308] min.
Minor diameter	28.40 - 28.58 [1.118 - 1.125]
Form diameter, min	32.59 [1.283]

XL4 disc valve motor series

Installation information (continued)

Specification	Data
Fillet radius	0.63 - 0.76 [0.025 - 0.030]
Tip radius	0.26 - 0.51 [0.010 - 0.020]
Finish	1.6 (63)
Involute profile variation	+0.000 -0.025 [+0.0000 -0.0010]
Total index variation	0.038 [0.0015]
Lead variation	0.013 [0.0005]
Circular space width	Maximum actual: 5.045 [0.1986]
	Minimum effective: 4.995 [0.1951]
	Maximum effective: Ref. 5.009 [0.1972]
	Minimum actual: Ref. 4.986 [0.1963]
Dimension between two pins	Ref. 22.783 - 22.929 [0.8970 - 0.9027]
Pin diameter	5.334 [0.2100] pins to have 3.73 [0.147] Wide flat for root clearance

XL4 disc valve motor series

Shaft dimensions

XL4 14 tooth splined (code 02) dimensions

31.75 [1.25] 14 tooth splined (code 02)

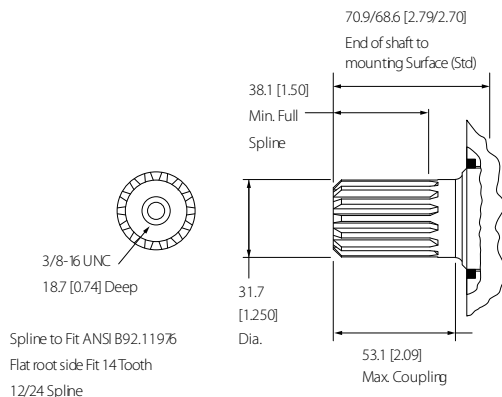

768 N·m [6800 in·lb] max. torque

XL4 17 tooth splined (code 03) dimensions

38.1 [1.50] 17 tooth splined (code 03)

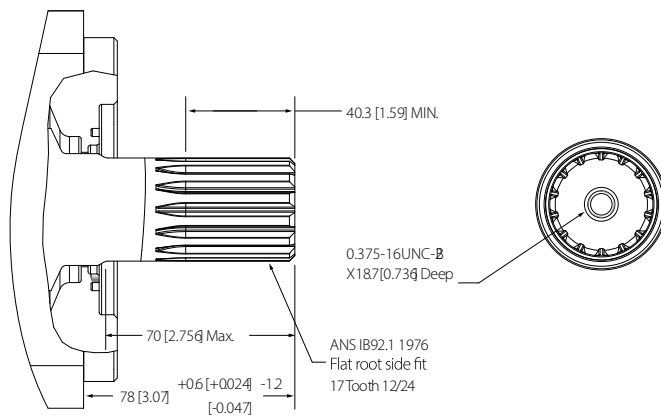

972 N·m [8600 in·lb] max. torque

XL4 disc valve motor series

XL4 40mm straight (code 04) dimensions

40mm straight (code 04)

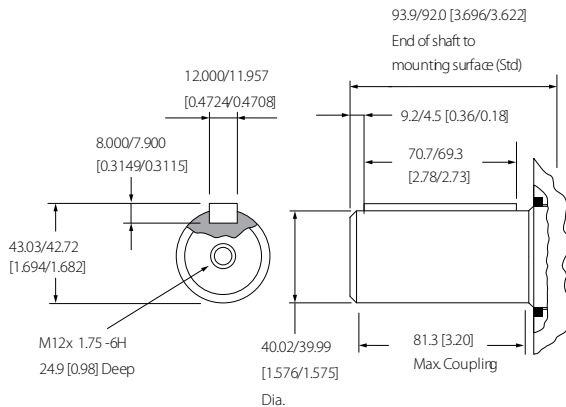

972 N·m [8600 in·lb] max. torque

XL4 17 tooth splined (code 05) dimensions

38.1 [1.50] 17 tooth splined (code 05)

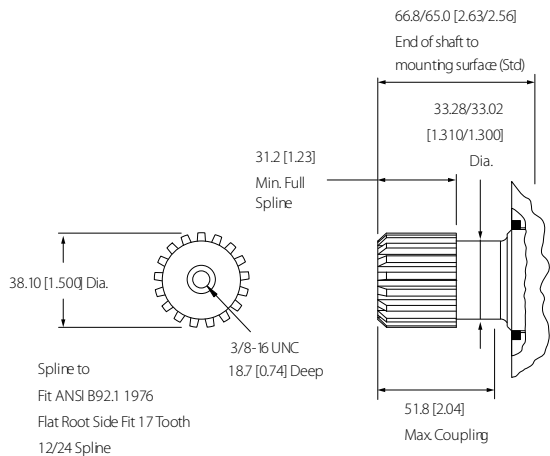

972 N·m [8600 in·lb] max. torque

XL4 disc valve motor series

XL4 ports dimensions

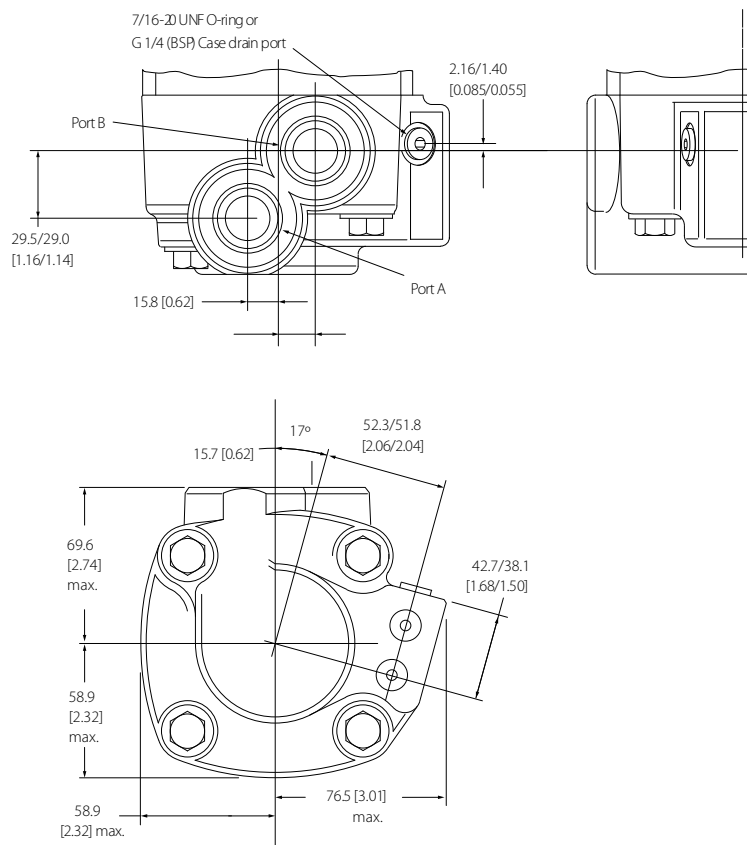

Preferred ports

Option	Description
AC and 03	AC: 1 1/16 -12 UN-2B SAE O-ring staggered ports (2) 03: 7/16 -20 UNF-2B SAE O-ring case drain port (1)
AB and 02	AB: G3/4 (B SP) staggered ports (2) 02: G1/4 (B SP) case drain port (1)
AA and 01	AA: M 27x2 staggered ports (2) 01: M14x1.5 case drain port (1)

XL4 disc valve motor series

Shaft side load capacity

These curves indicate the radial load capacity on the motor shaft(s) at various locations with an allowable external thrust load of 454 kg [1000 lb].

Case pressure will increase the allowable inward thrust load and decrease the allowable outward thrust load. Case pressure will push outward on the shaft at 94 kg/7 bar [208 lb/100 psi].

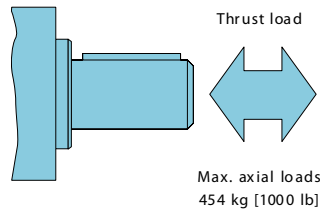

Each curve is based on a B10 bearing life of 2000 hours. The 12,000,000 revolution curve represents 100 RPM. The 3,000,000 revolution curve represents 25 RPM.

Standard motor straight and splined shafts

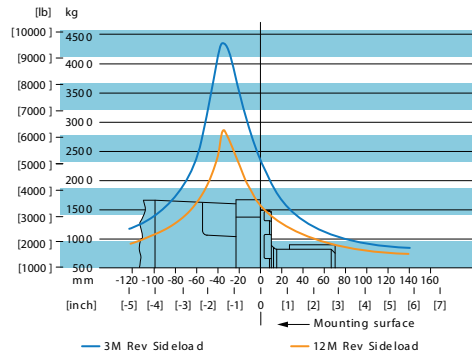

Wheel motor tapered shaft

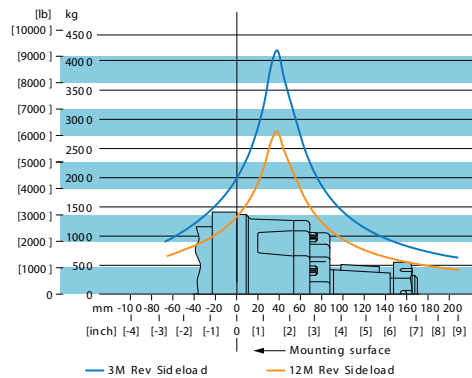

To determine radial load at speeds other than 25 RPM and 100 RPM, multiply the load values on the 12M revolution curve by the factors in the table below.

RPM	Multiplication factor
50	1.23
100	1.00
200	0.81
300	0.72
400	0.66
500	0.62

XL4 disc valve motor series

RPM	Multiplication factor
600	0.58
700	0.56
800	0.54

XL4 disc valve motor series

XL4 pressure seal limitation

Xcel XL4 Series motors are durable and have long life as long as the recommended case pressure is not exceeded.

Allowable case pressure is highest at low shaft speeds. Consequently, motor life will be shortened if case pressure exceeds these ratings (acceptability may vary with application). Determine if an external case drain is required from the case pressure seal limitation chart.

Case porting advantage contamination control Flushing motor case

Cooler motor Exiting oil draws motor heat away

Extended motor seal life Maintain low case pressure with a preset restriction in the case drain line

Case pressure seal limitation

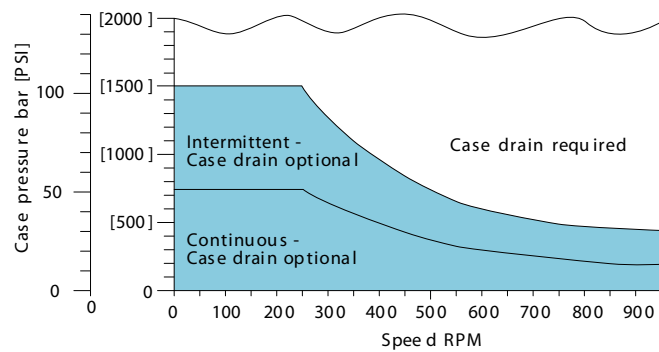

XL4 disc valve motor series

XL4 model code

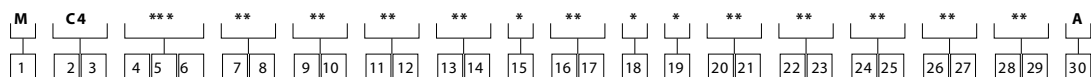

XL4 product, series, displacement options

1 - product

Code	Description
M	Motor

2, 3 - series

Code	Description
C4	Xcel XL4 series

4, 5, 6 - displacement

Code	Description
160	162.2 [9.90]
205	205.5 [12.54]
245	246.3 [15.03]
310	311.8 [19.03]
395	393.9 [24.04]
495	492.6 [30.06]

XL4 mounting flange and output shaft options

7, 8 - mounting flange

Code	Description
AA	Bearingless, 4 bolt: 127.00 [5.000] pilot dia. 14.27 [0.562] dia. holes on 161.92 [6.375] dia. bolt circle
AB	Standard, 4 bolt: 101.60 [4.000] pilot dia. 14.7 [0.58] slots on 127.00 [5.000] dia. bolt circle (SAE B)
AC	Standard, 4 bolt: 127.00 [5.000] pilot dia. 14.27 [0.562] dia. holes on 161.92 [6.375] dia. bolt circle (SAE C)
AD	Standard: ISO flange 125 B 4HW (ISO 3019/2) 124.97 [4.920] pilot dia. 14.27 [0.562] dia. holes on 160.00 [6.299] dia. bolt circle

9, 10 - output shaft

Code	Description
00	None (bearingless)
02	31.75 [1.250] dia. flat root side fit, 14 tooth, 12/24 DP 30° involute spline, 38.1 [1.50] minimum full spline length, with 0.375-16UNC-2B thread in end
03	38.10 [1.500] dia. flat root side fit, 17 tooth, 12/24 DP 30° involute spline, 40.3 [1.59] minimum full spline length, with 0.375-16 UNC-2B thread in end
04	40.00 [1.575] dia. straight with M12 x 1.75-6H thread, 7.955 [0.3132] x 11.979 [0.4716] wide x 69.98 [2.755] straight key
05	38.10 [1.500] dia. flat root side fit, 17 tooth, 12/24 DP 30° involute spline, 31.2 [1.23] minimum full spline length, with 0.375-16 UNC-2B thread in end

XL4 disc valve motor series

XL4 ports, case flow, pressure relief options

11, 12 - ports

Code	Description
AA	M 27x2- staggered ports
AB	G 3/4 ports -staggered ports
AC	1 1/16-12UN-2B SAE O-ring ports - staggered ports

13, 14 - case flow

Code	Description
01	M 14x1 .5 straight thread with check valve
02	G 1/4 B SP straight thread with check valve
03	7/16-20UNF-2B SAE O-ring port with check valve

15 - low pressure relief

Code	Description
0	None

16, 17 - pressure/flow setting

Code	Description
00	None

XL4 geroler, seal, accessories, special feature options

18 - geroler

Code	Description
0	Standard

19 - seal

Code	Description
0	Standard

20, 21 - accessories

Code	Description
00	None

22, 23 - special features (hardware)

Code	Description
00	None

24, 25 - special features (assembly)

Code	Description
00	None (standard)

XL4 disc valve motor series

XL4 paint, identification, design code options

26, 27 - paint/packaging

Code	Description
AA	Blue
AB	Black

28, 29 - customer identification or nameplate

Code	Description
00	None

30 - design code

Code	Description
A	First

XL6 disc valve motor series

About the XL6 series

Danfoss' Xcel™ series low speed, high torque disc valve motors offer the most popular features and options from the parallel Danfoss Char-Lynn range and are optimized to bring the highest value in medium duty applications.

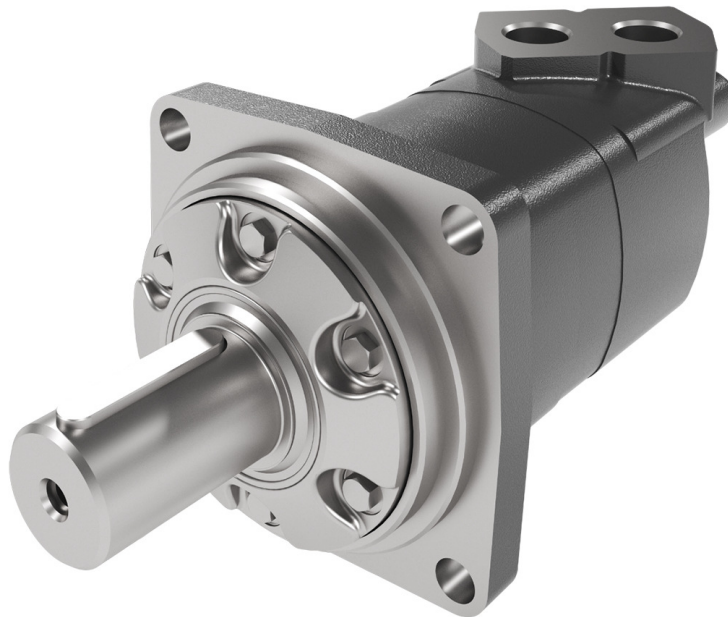

XL6 features, benefits, applications

Features

- 8 displacements, a variety of mounting flanges and output shafts
- Reliable, proven design
- High efficiency

Benefits

- Flexibility in designing this motor into a system
- Options that fit well into tough applications

Applications

- Mobile equipment
- Snow removal, mowing
- Sprayers
- Trenching machines
- Wood processing machines

XL6 disc valve motor series

XL6 specifications overview

Specification	Data
Geroler element	8 displacements
Flow l/min [US gal/min]	150 [40] continuous 225 [60] intermittent
Speed RPM	775 continuous 866 intermittent
Pressure bar [psi]	205 [3000] continuous 310 [4500] intermittent
Torque N-m [lb-in]	1685 [14920] continuous 1875 [16580] intermittent

Continuous motor may run continuously at the listed ratings

Intermittent 10% of every minute

XL6 disc valve motor series

XL6 part identification

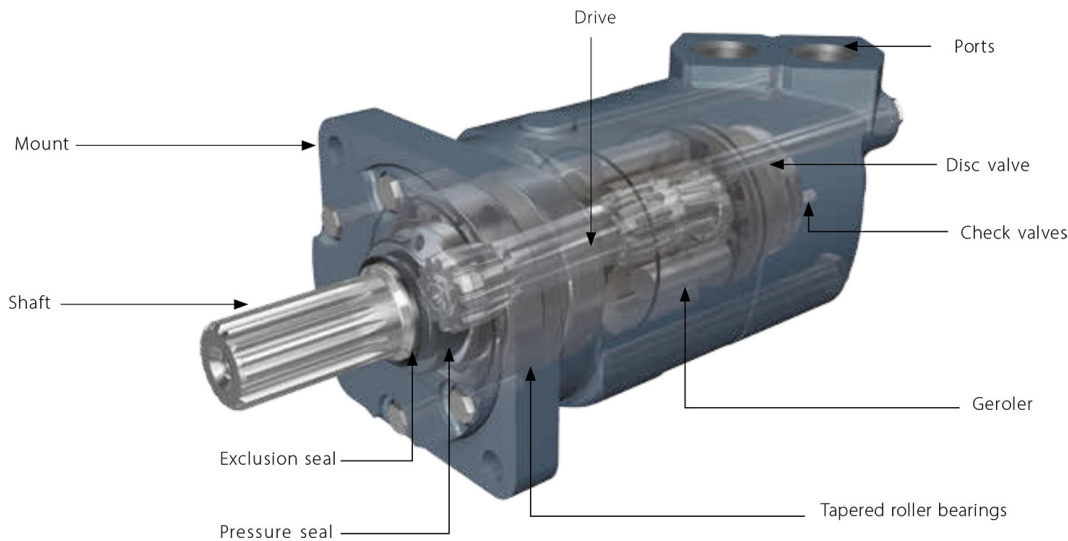

XL6 technical data

XL6 195cc-390cc technical data

Displacement cm³/r [in³]		195 [11.9]	245 [15.0]	310 [19.0]	390 [23.9]
Flow l/min [US gal/min]	Continuous	150 [40]	150 [40]	150 [40]	150 [40]
	Intermittent	170 [45]	210 [55]	225 [60]	225 [60]
Max. speed RPM	Continuous	775	615	485	387
	Intermittent	866	834	698	570
Pressure Δbar [Δpsi]	Continuous	205 [3000]	205 [3000]	205 [3000]	205 [3000]
	Intermittent	310 [4500]	310 [4500]	310 [4500]	310 [4500]
Torque* Nm [lb-in]	Continuous	575 [5100]	735 [6510]	930 [8230]	1155 [10230]
	Intermittent	860 [7620]	1100 [9740]	1355 [11990]	1635 [14490]
Weight	Standard or wheel mount	24.9 [55.0]	25.2 [55.5]	25.6 [56.5]	26.3 [58.0]
	Bearingless	20.2 [44.5]	20.4 [45.0]	20.9 [46.0]	21.5 [47.5]

* See shaft torque ratings for limitations.

XL6 490cc-985cc technical data

Displacement cm³/r [in³]		490 [30.0]	625 [38.0]	805 [49.0]	985 [60.0]
Flow l/min [US gal/min]	Continuous	150 [40]	150 [40]	150 [40]	150 [40]
	Intermittent	225 [60]	225 [60]	225 [60]	225 [60]
Max. speed RPM	Continuous	307	241	187	153
	Intermittent	454	355	289	230
Pressure Δbar [Δpsi]	Continuous	205 [3000]	170 [2500]	140 [2000]	140 [2000]
	Intermittent	275 [4000]	221 [3200]	170 [2500]	140 [2000]
Torque* Nm [lb-in]	Continuous	1445 [12800]	1480 [13100]	1582 [14004]	1685 [14920]
	Intermittent	1885 [16670]	1898 [16800]	1850 [16377]	1875 [16580]
Weight	Standard or wheel mount	27.0 [59.5]	27.9 [61.5]	29.0 [64.0]	30.4 [67.0]
	Bearingless	22.2 [49.0]	23.1 [51.0]	24.5 [53.5]	25.7 [56.5]

* See shaft torque ratings for limitations.

XL6 disc valve motor series

For maximum case pressure, see case pressure seal limitation graph.

- Δ bar [psi]** The true pressure difference between inlet port and outlet port.
- Continuous rating** Motor may be run continuously at these ratings.
- Intermittent operation** 10% of every minute.

To ensure best motor life, run motor for approximately 1 hour at 30% of rated pressure before application to full load. Be sure motor is filled with fluid prior to any load applications.

Recommended operating parameters

Data	Recommended
Max. inlet pressure	310 bar [4500 psi] <div style="color: red; font-weight: bold; font-size: 1.2em;">! Caution</div> <hr style="border: 1px solid red;"/> Do not exceed Δ pressure rating
Max. return pressure	310 bar [4500 psi] with case drain line installed <div style="color: red; font-weight: bold; font-size: 1.2em;">! Caution</div> <hr style="border: 1px solid red;"/> Do not exceed Δ pressure rating
Fluids	Premium quality, anti-wear type hydraulic oil with a viscosity of no less than 13 cSt [70 SUS] at operating temperature.
Operating temperature	-34 to 82 °C [-30 to 180 °F]
Filtration	Per ISO cleanliness code 4406:20/18/13

XL6 disc valve motor series

XL6 performance data

Performance data is typical at 25 cSt (120 SUS). Actual data may vary slightly from unit to unit in production.

XL6 195cc motor

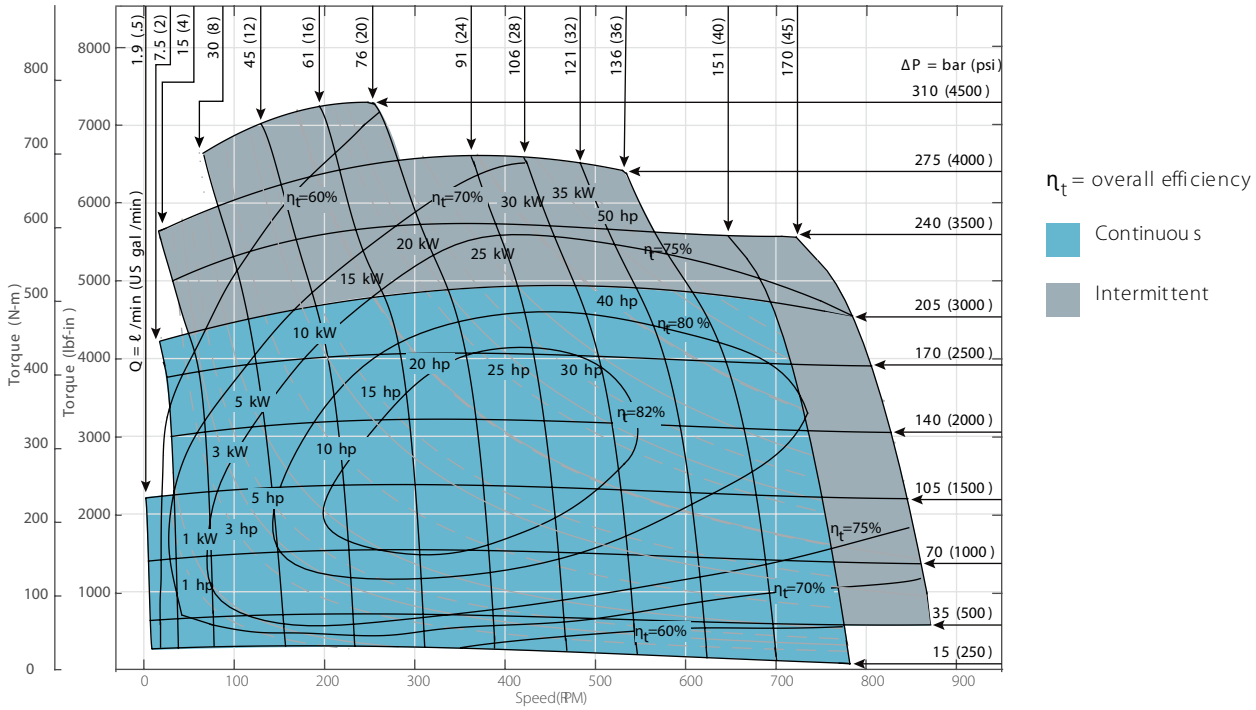

XL6 245cc motor

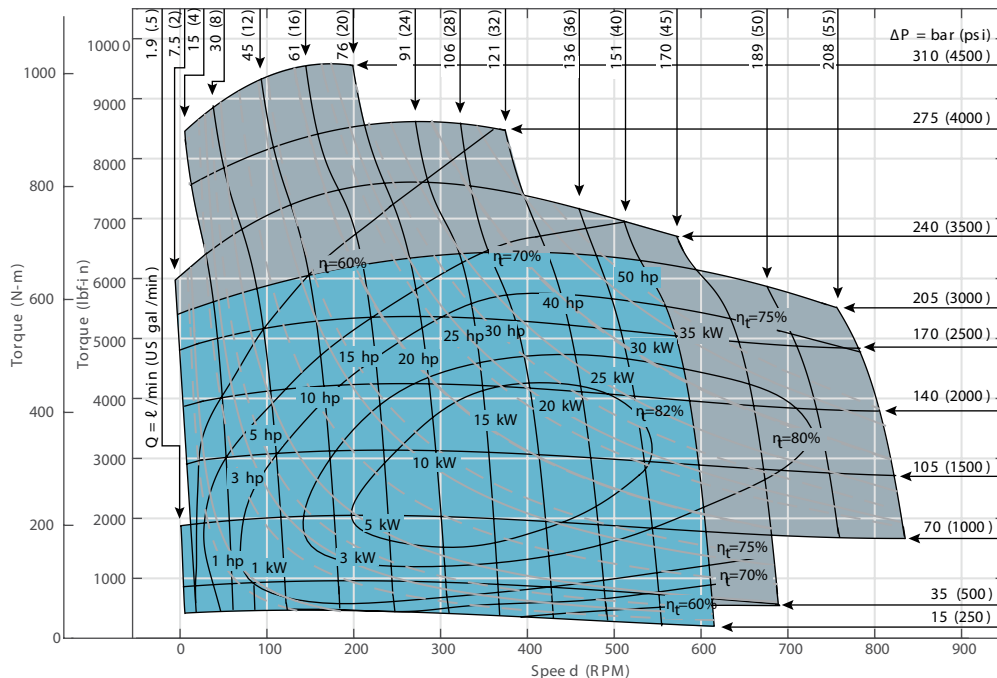

XL6 disc valve motor series

XL6 310cc motor

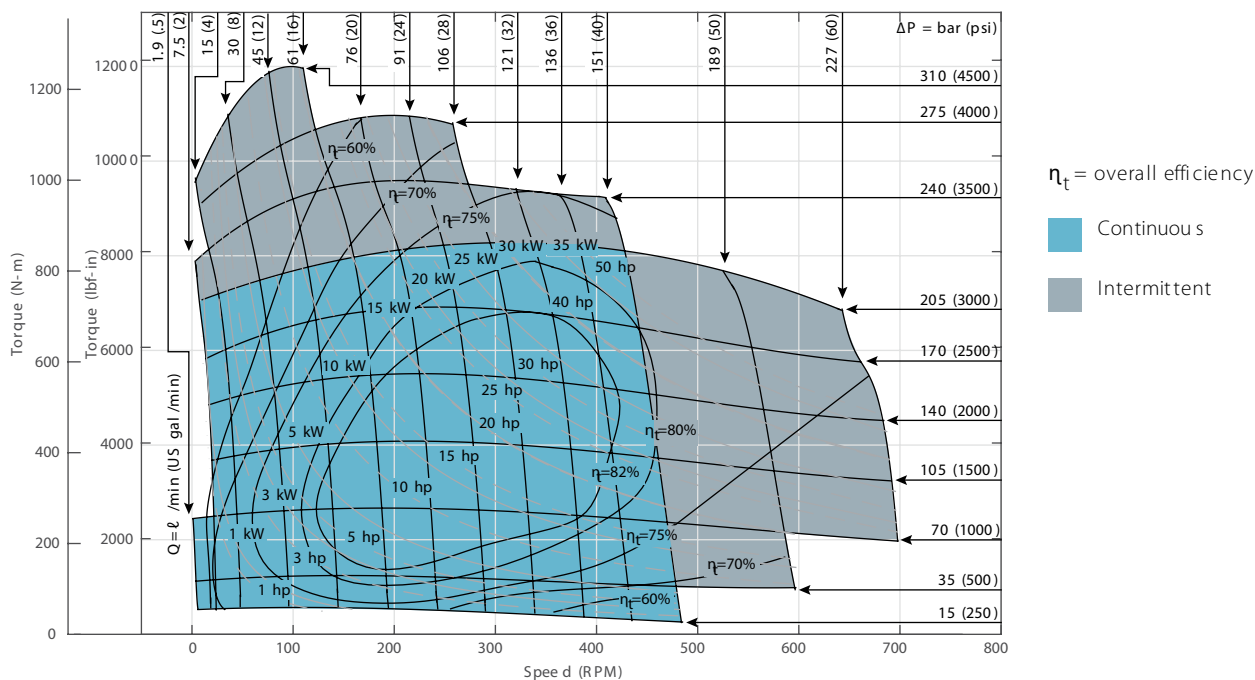

XL6 390cc motor

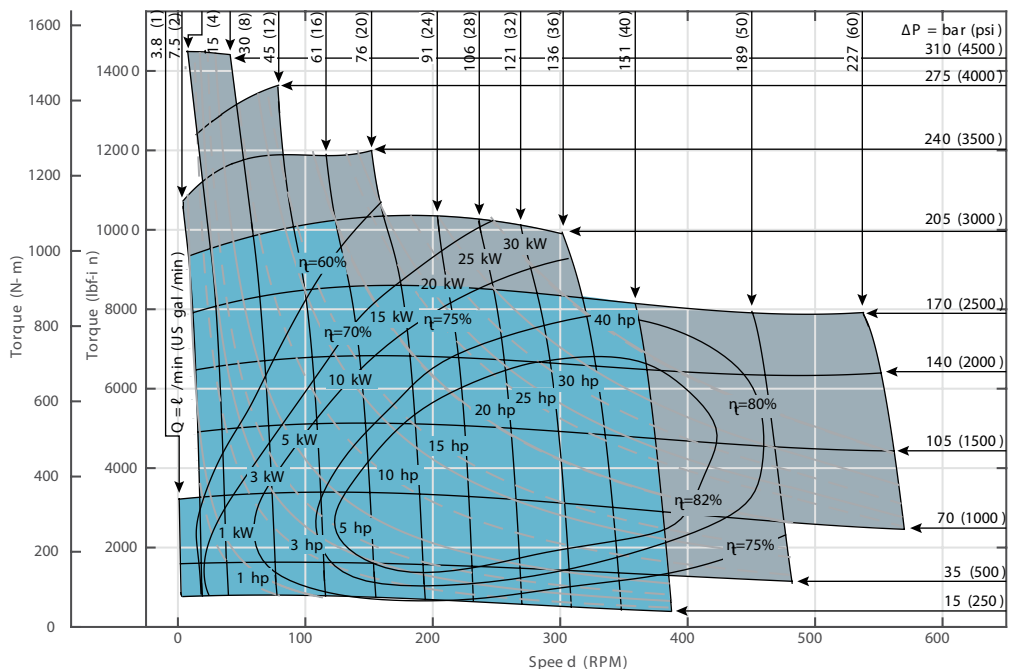

XL6 disc valve motor series

XL6 490cc motor

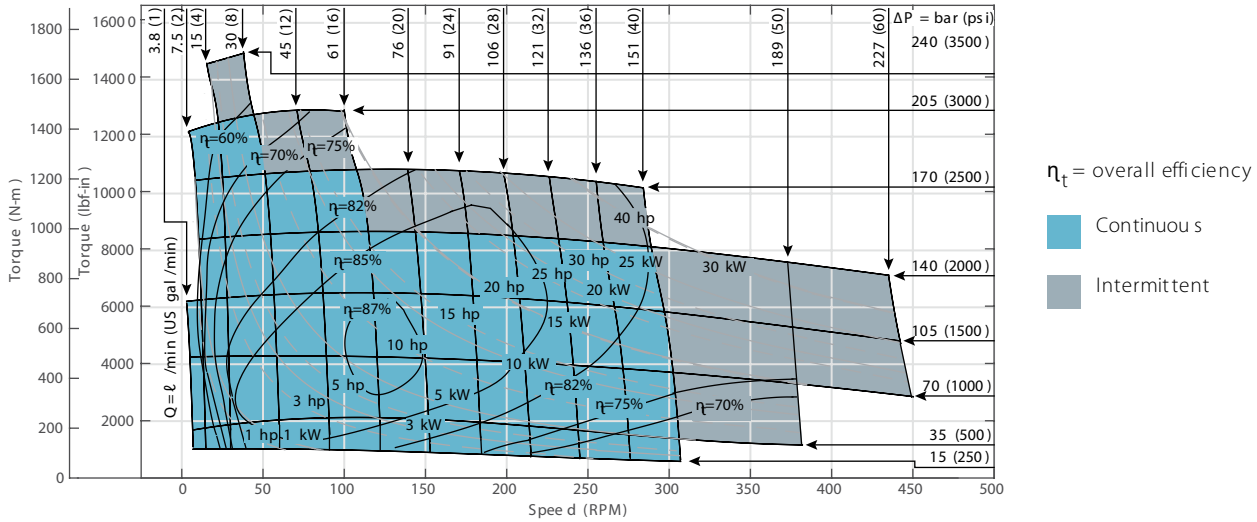

XL6 625cc motor

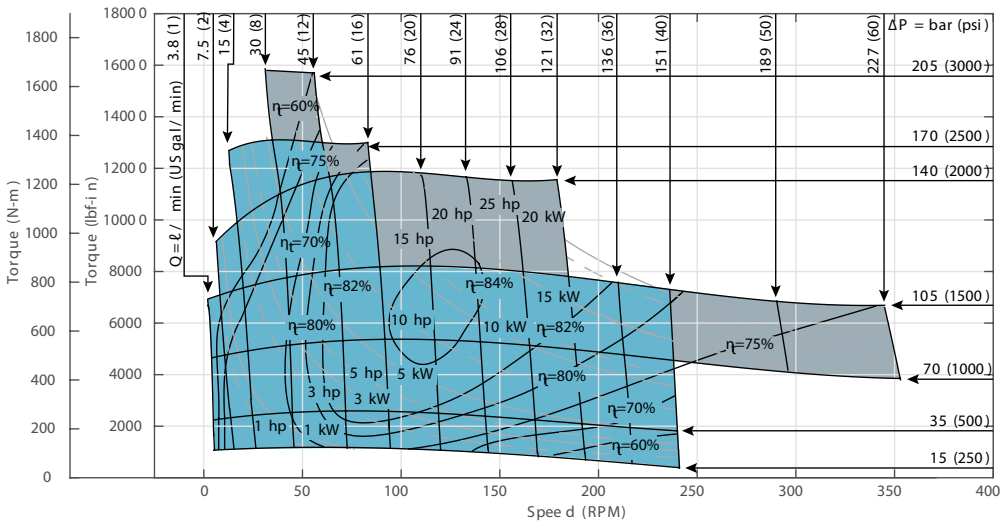

XL6 disc valve motor series

XL6 805cc motor

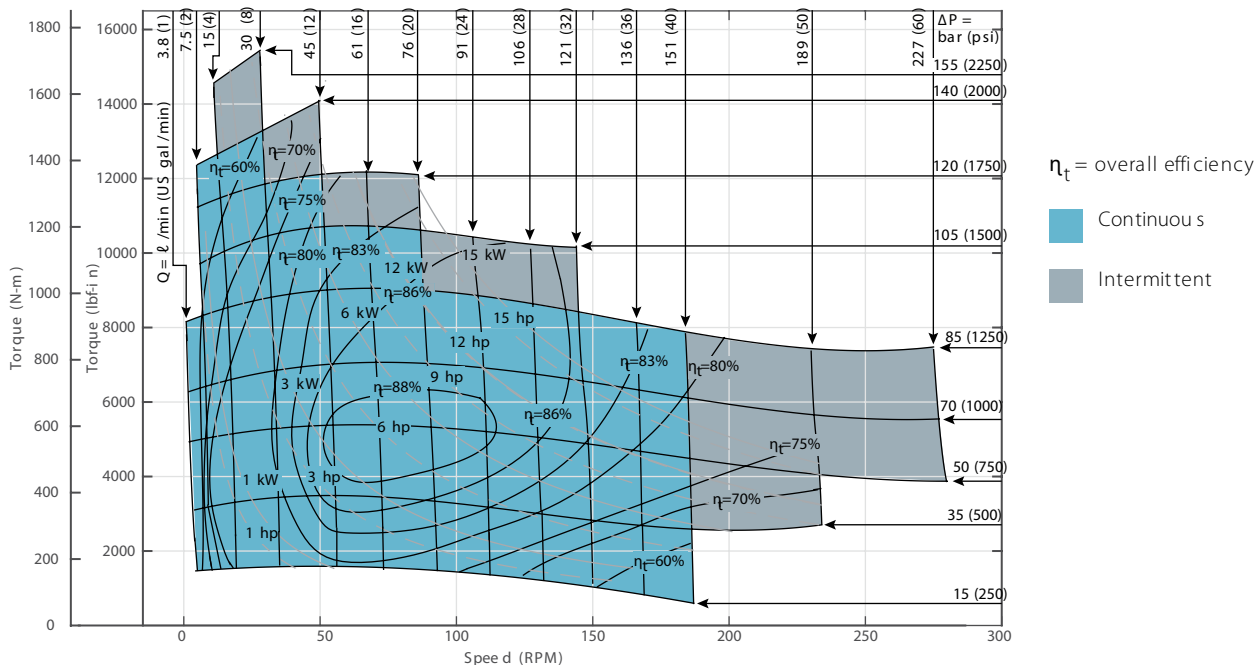

XL6 985cc motor

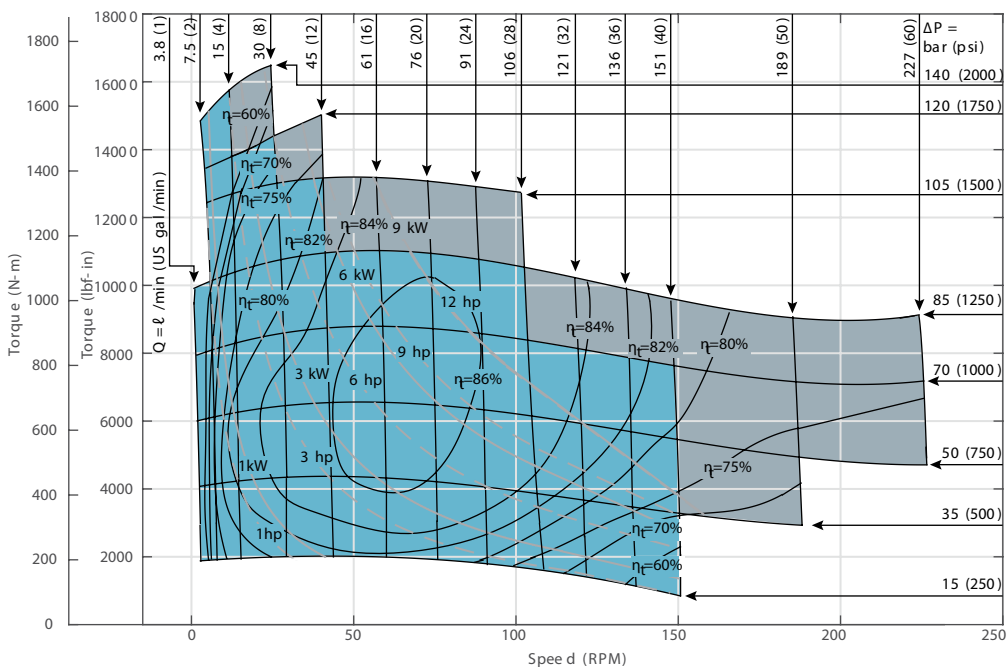

XL6 disc valve motor series

Mounting dimensions

XL6 standard mount dimensions

Ports

- 1 5/16 -12 UN-2B SAE O-ring staggered ports (2)
- 7/16 -20 UNF-2B SAE O-ring case drain port (1) or
- G 1 (BSP) staggered ports (2)
- G 1/4 (B SP) case drain port (1)

Standard rotation viewed from shaft end

- Port A pressurized - CW
- Port B pressurized - CCW

Standard mount (AB)

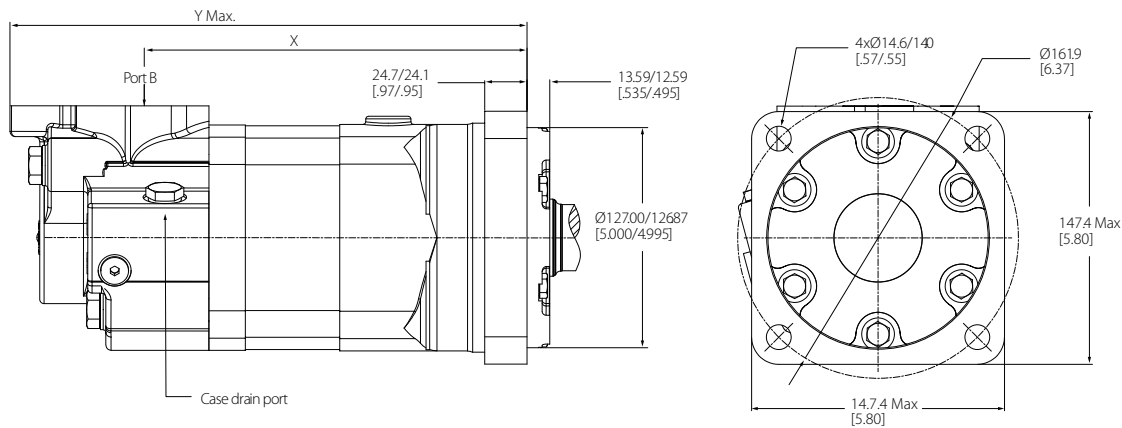

Dimensions

Displacement cm ³ /r [in ³ /r]	Dimensions in mm [in]	
	X	Y
195 [11.9]	187.5 [7.38]	270.0 [10.63]
245 [15.0]	193.0 [7.60]	275.6 [10.85]
310 [19.0]	200.1 [7.89]	283.0 [11.14]
390 [23.9]	209.0 [8.23]	291.6 [11.48]
490 [30.0]	220.2 [8.67]	302.8 [11.93]
625 [38.0]	235.0 [9.25]	317.5 [12.50]
805 [49.0]	254.8 [10.03]	337.3 [13.28]
985 [60.0]	274.6 [10.81]	357.1 [14.06]

XL6 disc valve motor series

XL6 wheel mount dimensions

Ports

- 1 5/16 -12 UN-2B SAE O-ring staggered ports (2)
- 7/16 -20 UNF-2B SAE O-ring case drain port (1) or
- G 1 (BSP) staggered ports (2)
- G 1/4 (B SP) case drain port (1)

Standard rotation viewed from shaft end

- Port A pressurized - CW
- Port B pressurized - CCW

Wheel mount (AC)

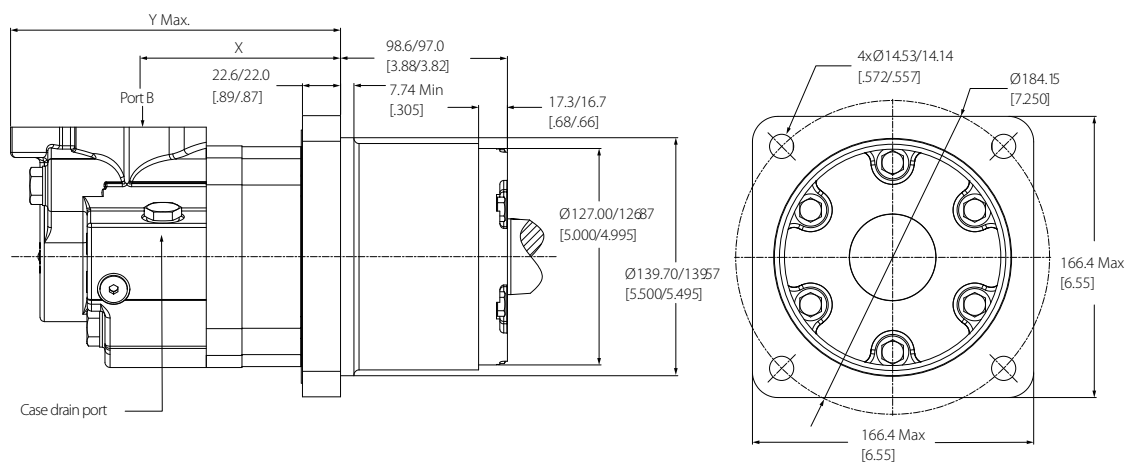

Dimensions

Displacement cm ³ /r [in ³ /r]	Dimensions in mm [in]	
	X	Y
195 [11.9]	102.6 [4.04]	185.2 [7.29]
245 [15.0]	108.2 [4.26]	190.8 [7.51]
310 [19.0]	115.6 [4.55]	198.1 [7.80]
390 [23.9]	124.5 [4.90]	207.1 [8.15]
490 [30.0]	135.4 [5.33]	217.9 [8.58]
625 [38.0]	150.1 [5.91]	232.7 [9.16]
805 [49.0]	169.9 [6.69]	252.7 [9.95]
985 [60.0]	189.7 [7.47]	272.5 [10.73]

XL6 disc valve motor series

XL6 global mount ISO dimensions

Ports

- 1 5/16 -12 UN-2B SAE O-ring staggered ports (2)
- 7/16 -20 UNF-2B SAE O-ring case drain port (1) or
- G 1 (BSP) staggered ports (2)
- G 1/4 (B SP) case drain port (1)

Standard rotation viewed from shaft end

- Port A pressurized - CW
- Port B pressurized - CCW

Global mount ISO (AH)

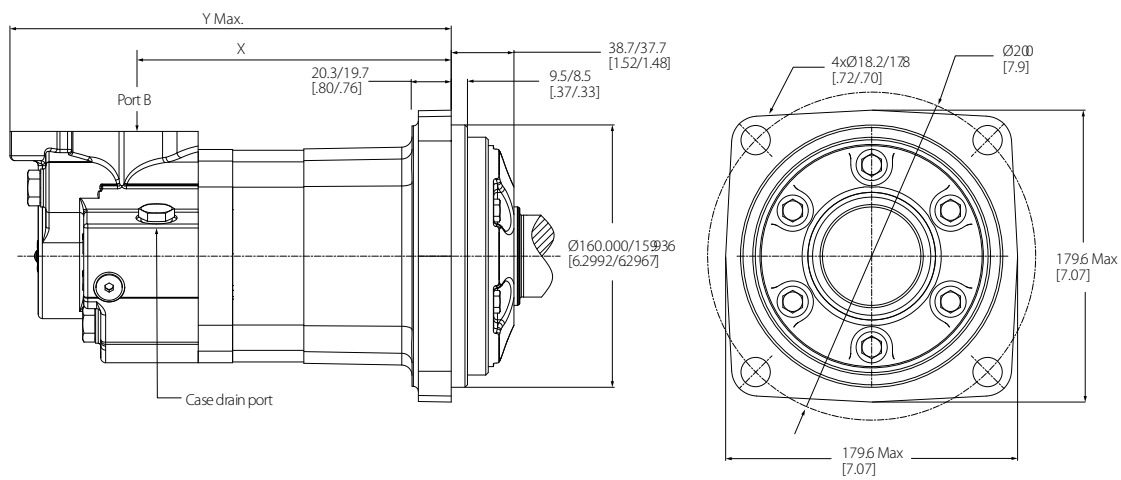

Dimensions

Displacement cm ³ /r [in ³ /r]	Dimensions in mm [in]	
	X	Y
310 [19.0]	182.4 [7.18]	264.9 [10.43]
390 [23.9]	191.0 [7.52]	273.6 [10.77]
490 [30.0]	202.2 [7.96]	284.7 [11.12]
625 [38.0]	216.9 [8.54]	299.5 [11.79]
805 [49.0]	236.7 [9.32]	319.3 [12.57]
985 [60.0]	256.5 [10.10]	339.1 [13.35]

XL6 disc valve motor series

XL6 bearingless mount dimensions

Ports

- 1 5/16-12 UN-2B SAE O-ring staggered ports (2)
- 7/16-20 UNF-2B SAE O-ring case drain port (1) or
- G 1 (BSP) staggered ports (2)
- G 1/4 (B SP) case drain port (1)

Standard rotation viewed from shaft end

- Port A pressurized - CW
- Port B pressurized - CCW

Bearingless mount (AA)

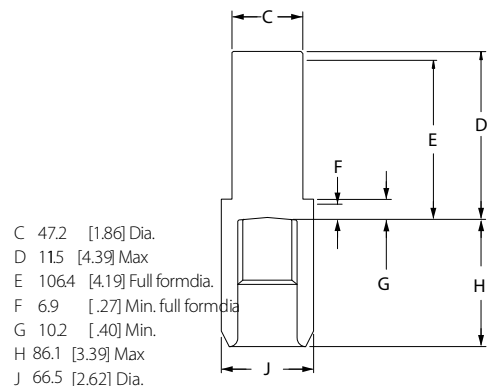
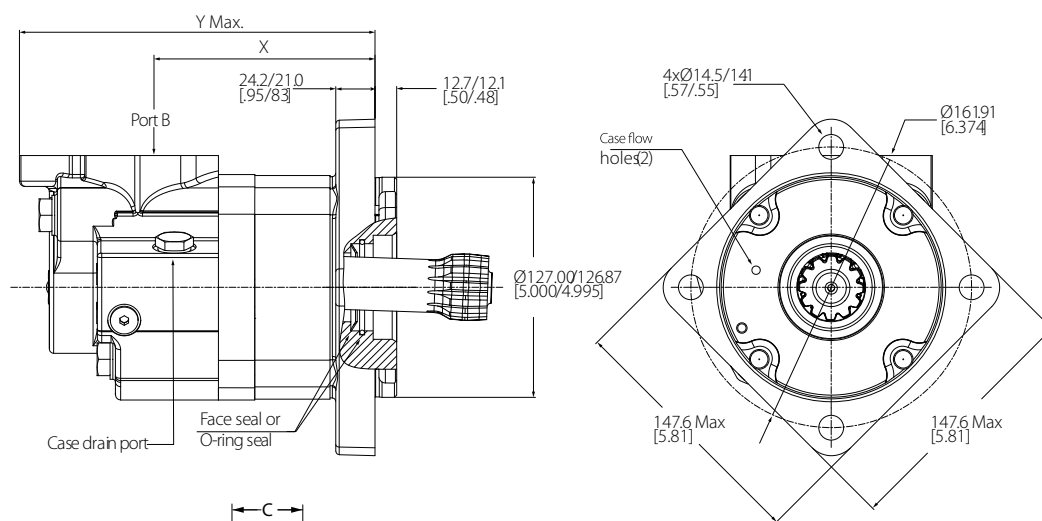

Mating Coupling Blank
 Danfoss Part No. 12778-00



Dimensions

Displacement cm ³ /r [in ³ /r]	Dimensions in mm [in]	
	X	Y
195 [11.9]	105.4 [4.15]	188.0 [7.40]
245 [15.0]	111.0 [4.37]	193.5 [7.62]
310 [19.0]	118.4 [4.66]	200.9 [7.91]
390 [23.9]	127.3 [5.01]	209.6 [8.25]
490 [30.0]	138.2 [5.44]	220.7 [8.69]

XL6 disc valve motor series

Dimensions (continued)

Displacement cm ³ /r [in ³ /r]	Dimensions in mm [in]	
	X	Y
625 [38.0]	152.9 [6.02]	235.5 [9.27]
805 [49.0]	173.0 [6.81]	255.3 [10.05]
985 [60.0]	192.8 [7.59]	275.1 [10.83]

For Xcel XL6 Series bearingless motor application information, contact your Danfoss representative.
Mating coupling blanks are available from Danfoss.

After machining blank, part must be hardened per Danfoss specification.

XL6 disc valve motor series

XL6 bearingless installation information

- Internal spline in mating part to be as follows: material to be ASTM A304, 8620H. Carbonize to a hardness of 60-64 HRC with case depth (to 50HRC) of 0.076 - 1.02 [0.030 - 0.040] (dimensions apply after heat treat).
- Mating part to have critical dimensions as shown. Oil holes must be provided and open for proper oil circulation.
- Seal to be furnished with motor for proper oil circulation.
- Some means of maintaining clearance between shaft and mounting flange must be provided.
- Similar to SAE "C" four bolt flange.
- Counterbore designed to adapt to a standard sleeve bearing 50.010 - 50.038 [1.9689 - 1.9700] ID by 60.051 - 60.079 [2.3642 - 2.3653] OD (Oilite bronze sleeve bearing).

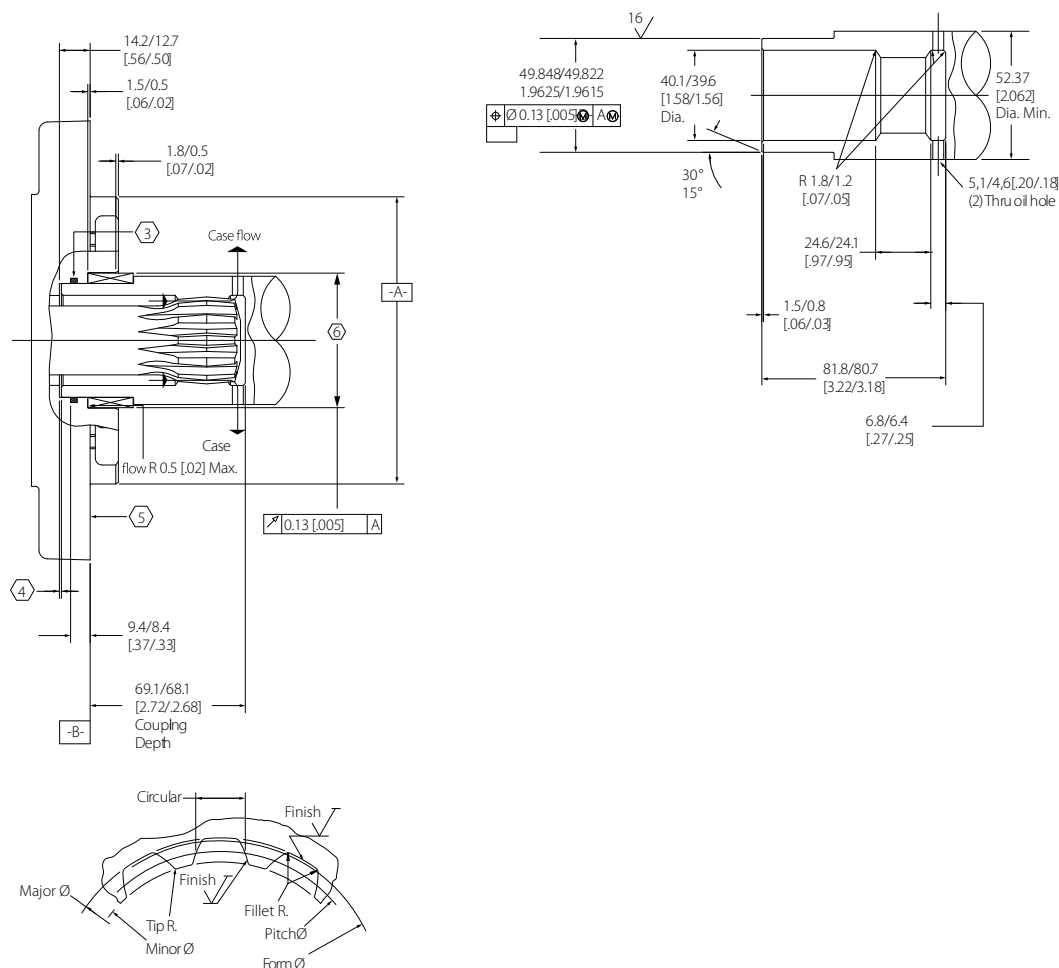

Installation information

Specification	Data
Spline pitch	8.5/17
Pressure angle	30°
Number of teeth	12
Class of fit	Ref. 5
Type of fit	Side
Pitch diameter	Ref. 35.858823 [1.4117647] 0.20 [0.008] D

XL6 disc valve motor series

Installation information (continued)

Specification	Data
Base diameter	Ref. 31.054652 [1.2226241]
Major diameter	39.17 [1.542] Max. 38,97 [1.534] min.
Minor diameter	33.30 - 33.48 [1.311 - 1.318]
Form diameter, min	38.33 [1.509]
Fillet radius	0.64 - 0.76 [0.025 - 0.030]
Tip radius	0.25 - 0.51 [0.010 - 0.020]
Finish	1.6 (63)
Involute profile variation	+0.000 -0.025 [+0.0000 -0.0010]
Total index variation	0.038 [0.0015]
Lead variation	0.013 [0.0005]
Circular space width	Maximum actual: 5.898 [0.2322]
	Minimum effective: 5.804 [0.2285]
	Maximum effective: Ref. 5.857 [0.2306]
	Minimum actual: Ref. 5.834 [0.2297]
Dimension between two pins	Ref. 26.929 - 27.084 [1.0602 - 1.0663]
Pin diameter	6.223 [0.2450] Pins to have 4.0 [0.160] Wide flat for root clearance

XL6 disc valve motor series

Shaft dimensions

XL6 straight (code 01) dimensions

38.1 [1.50] straight (code 01)

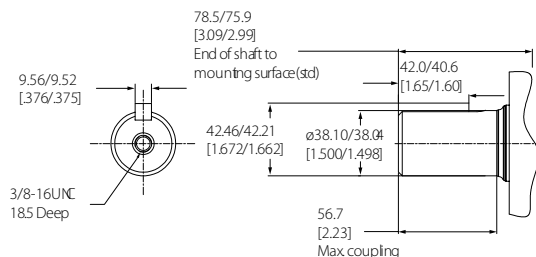

1328 N-m [11750 lb-in] max. torque

XL6 tapered (code 02) dimensions

44.4 [1.75] tapered (code 02)

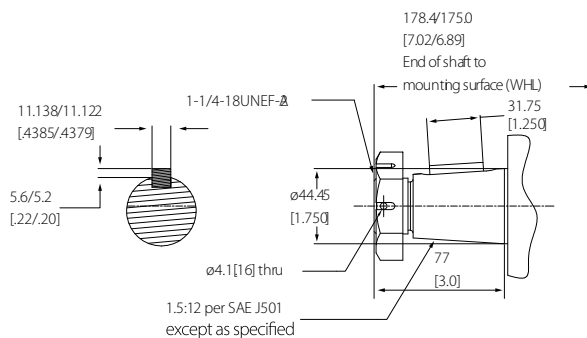

2107 N-m [18650 lb-in] max. torque

XL6 17 tooth splined (code 03) dimensions

38.1 [1.50] 17 tooth splined (03)

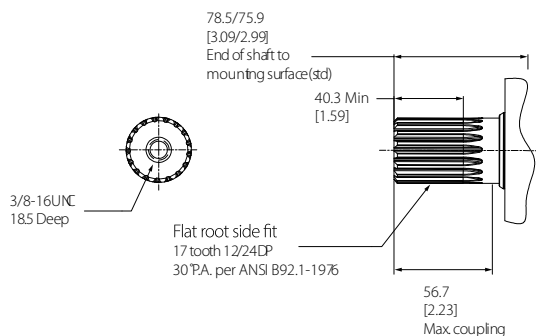

1328 N-m [11750 lb-in] max. torque

XL6 disc valve motor series

XL6 40mm straight (code 04) dimensions

40mm straight (code 04)

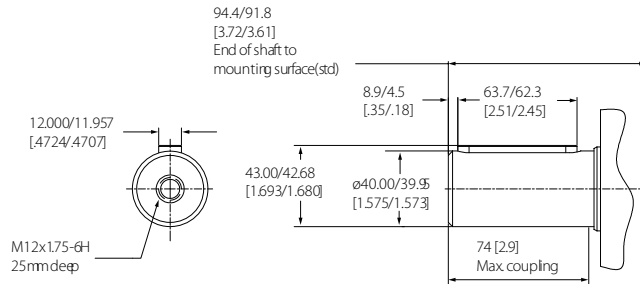

1328 N·m [11750 lb-in] max. torque

XL6 50mm straight (code 05) dimensions

50mm straight (code 05)

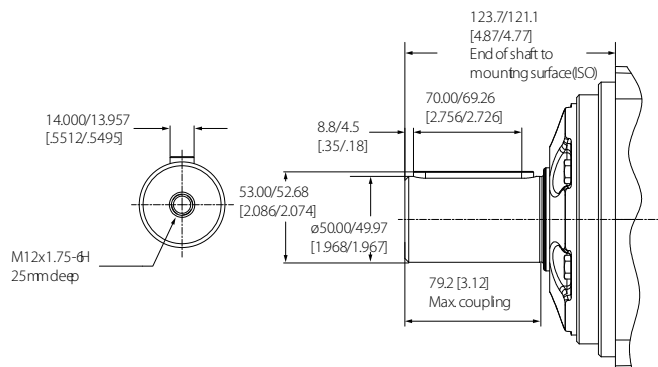

2107 N·m [18650 lb-in] max. torque

Only for use with mounting option AH.

XL6 disc valve motor series

XL6 ports dimensions

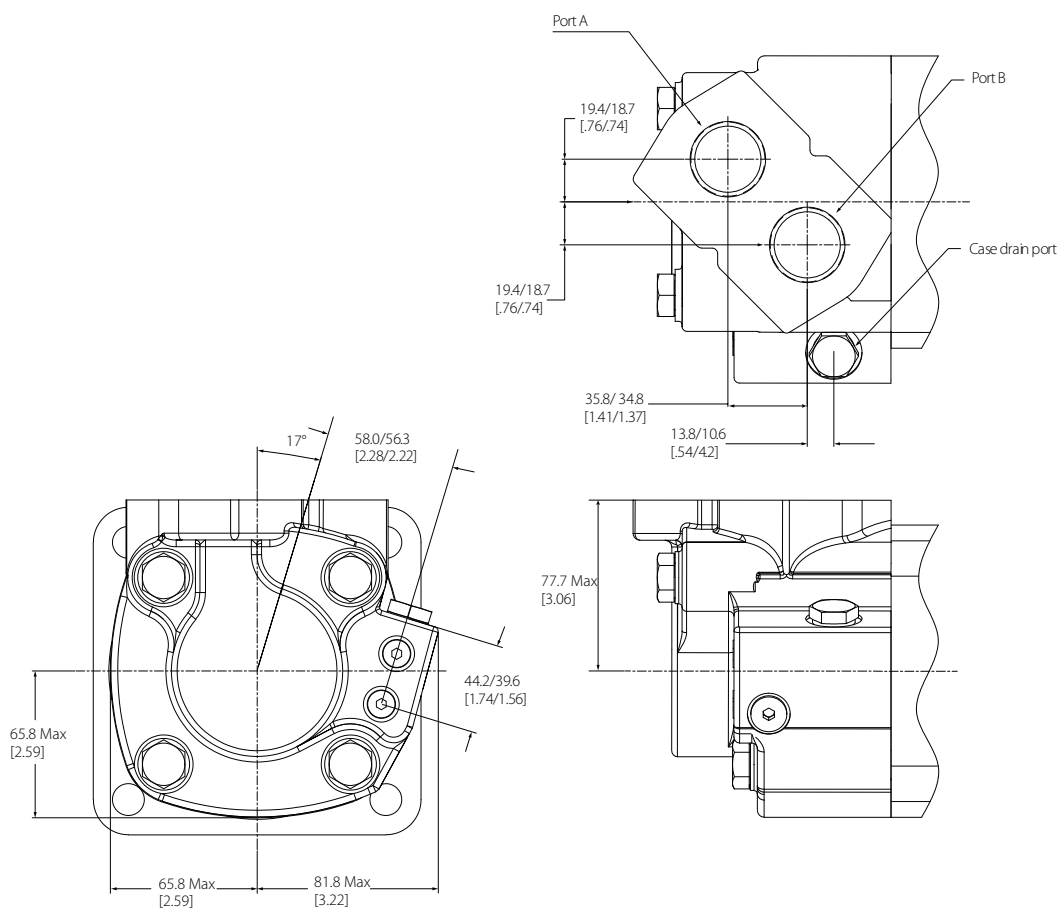

Ports

Option	Description
AA and 02	AA: 1 5/16-12 UN-2B SAE O-ring staggered ports (2) 02: 7/16-20 UNF-2B SAE O-ring case drain port (1)
AC and 03	AC: G 1 (BSP) staggered ports (2) 03: G 1/4 (BSP) case drain port (1)

XL6 disc valve motor series

XL6 side load capacity

These curves indicate the radial load capacity on the motor shaft(s) at various locations with an external thrust load of 454 kg [1000 lb]. The maximum allowable thrust load is 908 kg [2000 lb].

Case pressure will increase the allowable inward thrust load and decrease the allowable outward thrust load. Case pressure will push outward on the shaft at 109 kg/7 Bar [241 lb/100 PSI] .

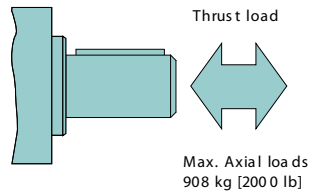

Standard motor with straight and splined shafts

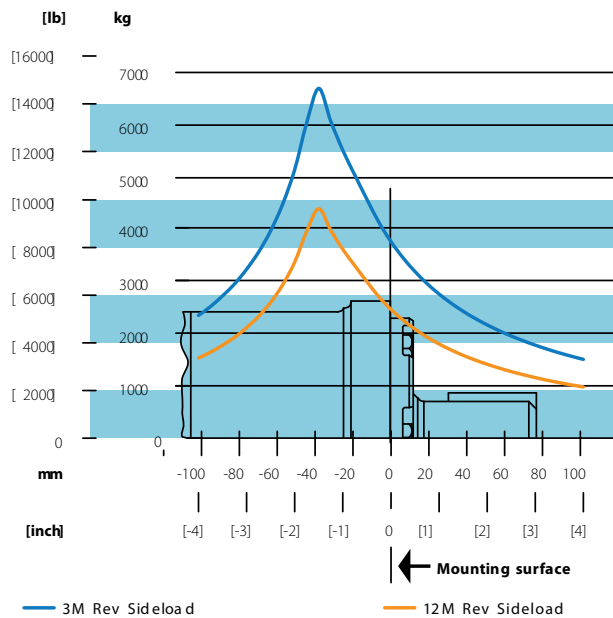

XL6 disc valve motor series

Wheel motor with tapered shaft

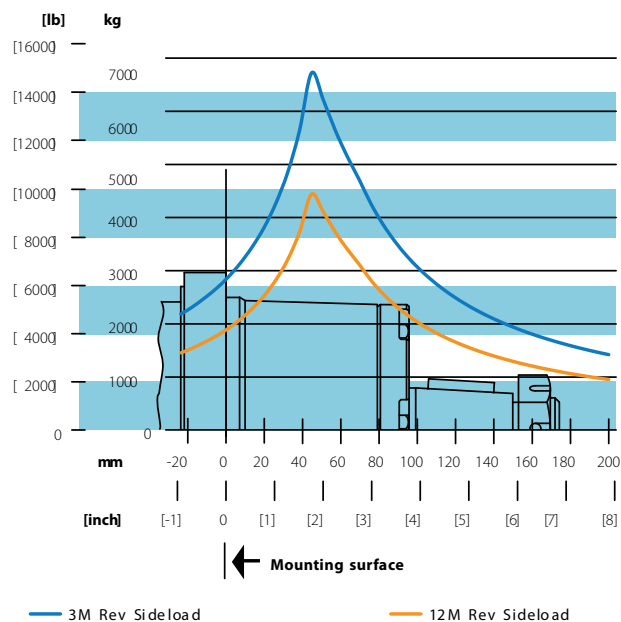

Each curve is based on B 10 bearing life (2000 hours of 12,000,000 shaft revolutions at 100 RPM) at rated output torque. To determine radial load at speeds other than 100 R P M, multiply the load values given on the bearing curve by the factors in the chart below.

RPM	Multiplication factor
50	1.23
100	1.00
200	0.81
300	0.72
400	0.66
500	0.62
600	0.58
700	0.56
800	0.54

XL6 disc valve motor series

XL6 case pressure seal limitation

Xcel XL6 series motors are durable and have long life as long as the recommended case pressure is not exceeded. Allowable case pressure is highest at low shaft speeds. Consequently, motor life will be shortened if case pressure exceeds these ratings (acceptability may vary with application). Determine if an external case drain is required from the case pressure seal limitation chart.

Case porting advantage contamination control Flushing motor case

Cooler motor Exiting oil draws motor heat away

Extended motor seal life Maintain low case pressure with a preset restriction in the case drain line

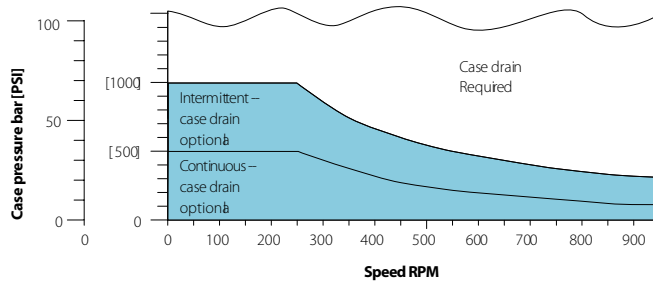

XL6 disc valve motor series

XL6 model code

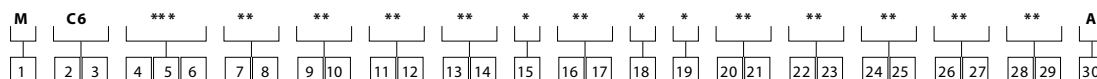

XL6 product, series, displacement options

1 - product

Code	Description
M	Motor

2, 3 - series

Code	Description
C6	Xcel XL6 series

4, 5, 6 - displacement

Code	Description
195	195 [11.9]
245	245 [15.0]
310	310 [19.0]
390	390 [23.9]
490	490 [30.0]
625	625 [38.0]
805	805 [49.0]
985	985 [60.0]

XL6 mounting flange and output shaft options

7, 8 - mounting

Code	Description
AA	Bearingless, 4 bolt: 127.0 [5.00] pilot dia. 14.35 [0.565] dia. holes on 162.0 [6.38] dia. bolt circle
AB	Standard, (SAE C), 4 bolt: 127.0 [5.00] pilot dia. 14.35 [0.565] dia. holes on 162.0 [6.38] dia. bolt circle
AC	Wheel, 4 bolt: 139.7 [5.50] pilot dia. 14.35 [0.565] dia. holes on 184.2 [7.25] dia. bolt circle
AH	Standard, 4 bolt: 160.0 [6.30] pilot dia. 18.01 [0.709] dia. holes on 200.0 [7.87] dia. bolt circle

9, 10 - output shaft

Code	Description
00	None (bearingless)
01	38.10 [1.500] dia. straight shaft with 0.375 - 16 UNC-2B thread in end, 9.52 [0.375] sq x 41.28 [1.625] straight key
02	44.45 [1.750] dia. 0.125:1 tapered shaft per SAE J501 with 1.250-18 UNEF-2A threaded shaft end, 11.11 [0.4375] sq. x 31.8 [1.25] straight key
03	38.10 [1.500] dia. flat root side fit, 17 tooth, 12/24 DP 30° involute spline with 0.375-16 UNC-2B thread in end 40.4 [1.59] minimum full spline length

XL6 disc valve motor series

9, 10 - output shaft (continued)

Code	Description
04	40.00 [1.575] dia. straight shaft with M12 x 1.75-6 H thread in end, 12 W x 8 H x 63 L [0.472 W x 0.313 H x 2.480 L] key
05	49.99 [1.968] dia. straight shaft with M12 x 1.75-6 H thread in end, 14 W x 9 H x 70 L [0.550 W x 0.354 H x 2.756 L] key

XL6 port, case flow, pressure relief options

11, 12 - ports

Code	Description
AA	1.3125-12 UN-2B SAE O-ring staggered ports
AC	G 1 staggered ports

13, 14 - case flow

Code	Description
02	0.4375-20 UNF-2B SAE O-ring port with check valve
03	G 1/4 BSP straight thread port with check valve

15 - low pressure relief

Code	Description
0	None

16, 17 - pressure/flow

Code	Description
00	None

XL6 geroler, seal, accessory, special feature options

18 - geroler

Code	Description
0	None

19 - seal

Code	Description
0	Standard

20, 21 - accessories

Code	Description
00	None

22, 23 - special features (hardware)

Code	Description
00	None

XL6 disc valve motor series

24, 25 - special features (assembly)

Code	Description
00	None (standard)

XL6 paint, identification, design code options

26, 27 - paint/packaging

Code	Description
AA	Blue
AB	Black

28, 29 - customer identification or nameplate

Code	Description
00	None

30 - design code

Code	Description
A	First

[For additional special features, contact your Danfoss representative.](#)

Products we offer:

- Cylinders
- Electric converters, machines, and systems
- Electronic controls, HMI, and IoT
- Hoses and fittings
- Hydraulic power units and packaged systems
- Hydraulic valves
- Industrial clutches and brakes
- Motors
- PLUS+1[®] software
- Pumps
- Steering
- Transmissions

Danfoss Power Solutions designs and manufactures a complete range of engineered components and systems. From hydraulics and electrification to fluid conveyance, electronic controls, and software, our solutions are engineered with an uncompromising focus on quality, reliability, and safety.

Our innovative products makes increased productivity and reduced emissions a possibility, but it's our people who turn those possibilities into reality. Leveraging our unsurpassed application know-how, we partner with customers around the world to solve their greatest machine challenges. Our aspiration is to help our customers achieve their vision — and to earn our place as their preferred and trusted partner.

Go to www.danfoss.com or scan the QR code for further product information.

**Hydro-Gear**

www.hydro-gear.com

Daikin-Sauer-Danfoss

www.daikin-sauer-danfoss.com

**Danfoss
Power Solutions (US) Company**
2800 East 13th Street
Ames, IA 50010, USA
Phone: +1 515 239 6000

**Danfoss
Power Solutions GmbH & Co. OHG**
Krokamp 35
D-24539 Neumünster, Germany
Phone: +49 4321 871 0

**Danfoss
Power Solutions ApS**
Nordborgvej 81
DK-6430 Nordborg, Denmark
Phone: +45 7488 2222

**Danfoss
Power Solutions Trading
(Shanghai) Co., Ltd.**
Building #22, No. 1000 Jin Hai Rd
Jin Qiao, Pudong New District
Shanghai, China 201206
Phone: +86 21 2080 6201

Danfoss can accept no responsibility for possible errors in catalogues, brochures and other printed material. Danfoss reserves the right to alter its products without notice. This also applies to products already on order provided that such alterations can be made without subsequent changes being necessary in specifications already agreed. All trademarks in this material are property of the respective companies. Danfoss and the Danfoss logotype are trademarks of Danfoss A/S. All rights reserved.