

MONOBLOCK DIRECTIONAL  
CONTROL VALVE

**D5**

## Features

Simple, compact and heavy duty designed monoblock valves from 1 to 7 sections for open and closed centre hydraulic systems..

- Fitted with a main pressure relief valve and a load check valve.
- Available with parallel, series or tandem circuit.
- Optional carry-over port (only for parallel or tandem circuit).
- Diameter 16 mm - 0.63 in interchangeable spools.
- A wide variety of service port valve options.
- Actuation is manual, pneumatic, electro-pneumatic, hydraulic, electro-hydraulic, with solenoid and remote with flexible cables spool control kits.

### Additional information

This catalogue shows the product in the most standard configurations.  
Please contact Sales Dpt. for more detailed information or special request.

### WARNING!

All specifications of this catalogue refer to the standard product at this date.  
Walvoil, oriented to a continuous improvement, reserves the right to discontinue, modify or revise the specifications, without notice.

**WALVOIL IS NOT RESPONSIBLE FOR ANY DAMAGE CAUSED BY AN  
INCORRECT USE OF THE PRODUCT.**

3<sup>rd</sup> edition September 2012:

**This edition supercedes all prior documents.**

<b>Working condition</b> .....	<b>4</b>
<b>Performance data</b> .....	<b>5</b>
<b>Directional valve with left inlet</b> .....	<b>7</b>
<b>Directional valve with right inlet</b> .....	<b>77</b>
<b>Installation and maintenance</b> .....	<b>126</b>
<b>Accessories</b> .....	<b>129</b>

## Working conditions

This catalogue shows technical specifications and diagrams measured with mineral oil of 46 mm<sup>2</sup>/s - 46 cSt viscosity at 40°C temperature.

Nominal flow rating		45 l/min	
Operating pressure (max.)	<i>parallel pr tandem circuit</i>	315 bar	4600 psi
	<i>series circuit</i>	250 bar	3600 psi
Max. back pressure	<i>on outlet port T</i>	25 bar	360 psi
Internal leakage A(B)→T	$\Delta p=100 \text{ bar} - 1450 \text{ psi}$ with fluid and valve at 40 °C	3 cm <sup>3</sup> /min	0.18 in <sup>3</sup> /min
Hydraulic fluid		Mineral base oil	
Fluid temperature	<i>with NBR seals</i>	from -20° to 80°C	
	<i>with FPM seals</i>	from -20° to 100°C	
Viscosity	<i>operating range</i>	from 15 to 75 mm <sup>2</sup> /s	from 15 to 75 cSt
	<i>minimum</i>	12 mm <sup>2</sup> /s	12 cSt
	<i>maximum</i>	400 mm <sup>2</sup> /s	400 cSt
Max. level of contamination		19/16 - ISO 4406	
Ambient temperature	<i>with mechanical, pneumatic and hydraulic devices</i>	from -40° to 60°C	
	<i>with electric devices</i>	from -20° to 60°C	

NOTE - For different conditions please contact Sales Dept.

## Standard threads

### REFERENCE STANDARDS

		BSP	UN-UNF	METRIC	NPTF
THREAD ACCORDING TO		ISO 228/1	ISO 263	ISO 262	ANSI B1.20.3
		BS 2779	ANSI B1.1 unified		
CAVITY ACCORDING TO	ISO	1179	11926	9974-1	
	SAE		J1926	J2244	J476a
	DIN	3852-2 shape X o Y		3852-1 shape X o Y	

### PORTS THREAD

MAIN PORTS	BSP	UN-UNF	METRICA
Inlet <b>P</b> and carry-over <b>C</b>	G 3/8	3/4-16 (SAE 8)	M18x1,5
Ports <b>A</b> and <b>B</b>	G 3/8	9/16-18 (SAE 6)	M18x1,5
Outlet <b>T</b>	G 3/8 G 1/2 *	3/4-16 (SAE 8)	M18x1,5 M22x1,5 *
CONTROL PILOT PORTS			
Pneumatics	NPTF 1/8-27	NPTF 1/8-27	NPTF 1/8-27
Hydraulics	G 1/4	9/16-18 (SAE 6)	G 1/4

(\*) - Only for series circuit..

Performance data (pressure drop vs. flow)

Open centre

From side inlet to side outlet.

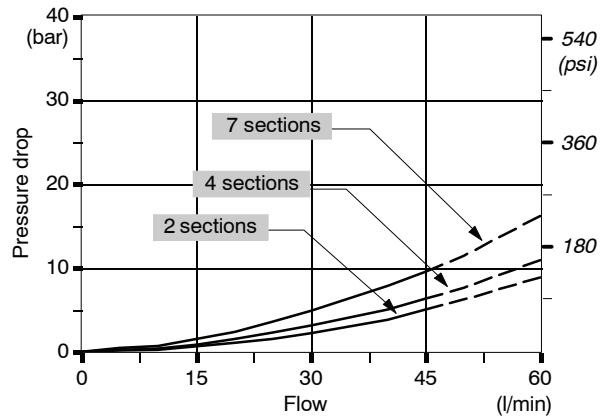
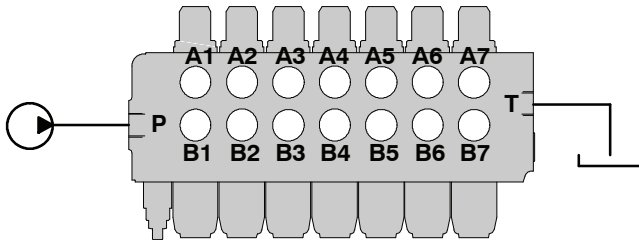

Inlet to work port

From side inlet to A port (spool in position 1) or B port (spool in position 2).

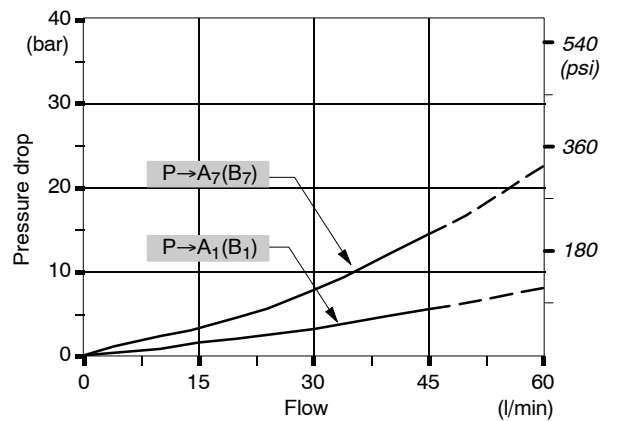
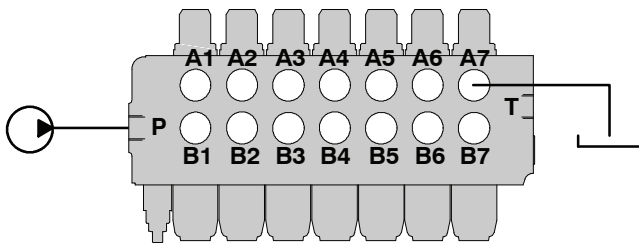

Work port to outlet

From A port (spool in position 2) or B port (spool in position 1) to side outlet.

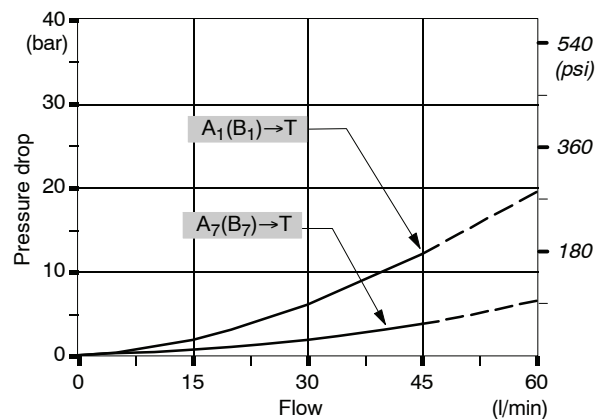
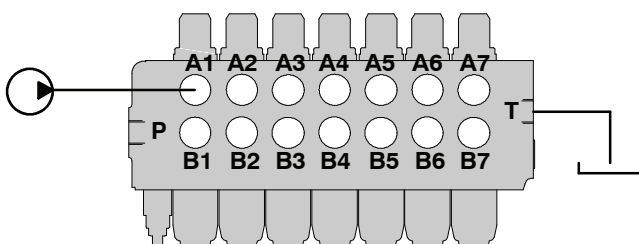

NOTE - Measured with spool type 1.





### Directional valve with parallel circuit

Dimensional data .....	8
Hydraulic circuit .....	9
Ordering codes .....	10
Inlet relief options .....	12
Spools .....	13
“A” side spool positioners .....	20
“B” side options .....	39
Complete controls .....	44
Outlet port options .....	49
Service and auxiliary valves	
ordering codes .....	52
port relief valves .....	54
pilot check valves .....	56
flange mounted relief valves .....	55
antishock valves .....	57
fixed setting antishock and anticavitation valves .....	59
adjustable setting antishock and anticavitation valves .....	61
flow control valves .....	65
<b>Other executions</b>	
Main features .....	69
Directional valve SD5/1-N .....	70
Directional valve SD5/1-D .....	71
Directional valve SD5-S with series circuit .....	72
Directional valve SD5-SP with tandem circuit .....	74

Dimensional data (parallel circuit)

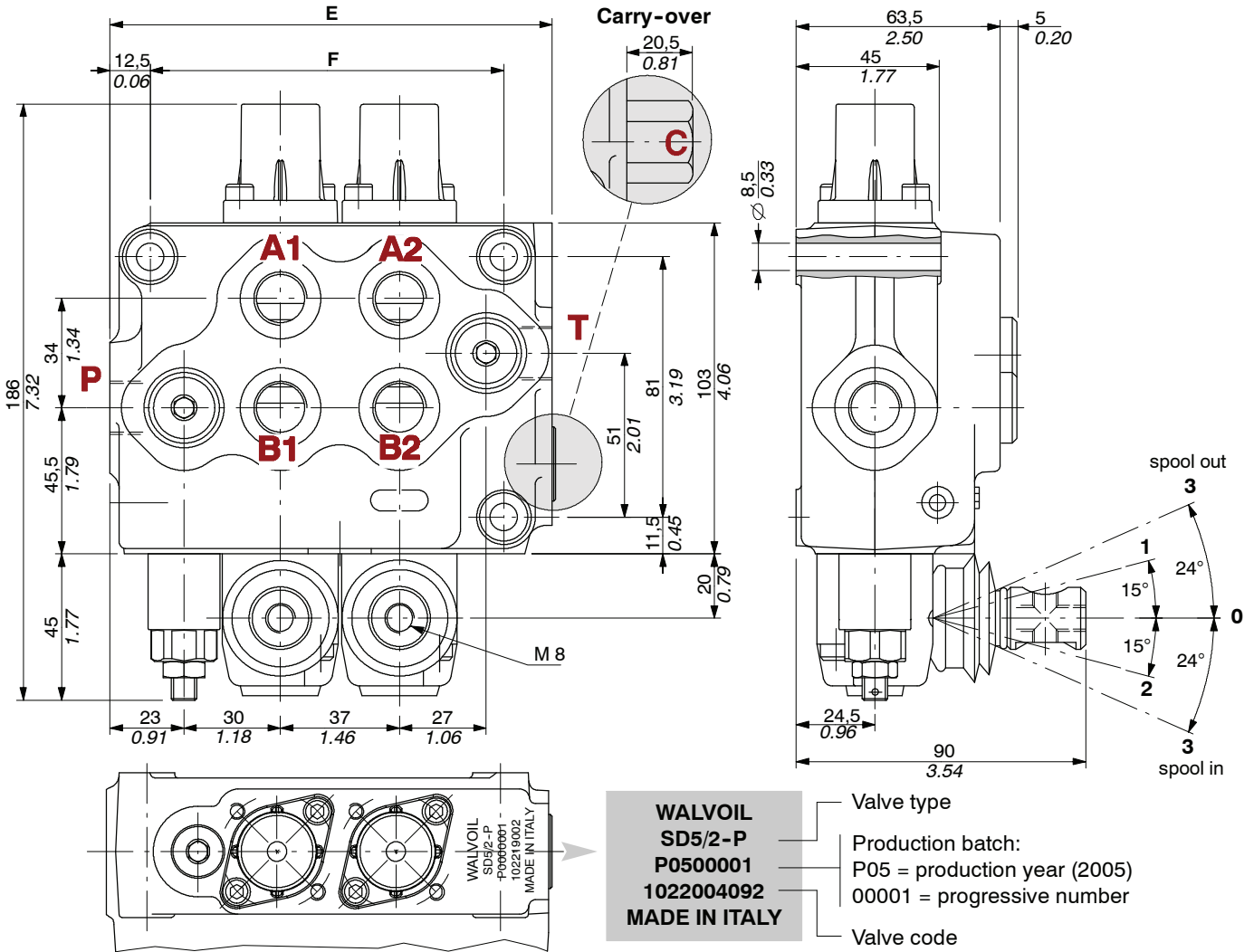

TYPE	E		F		Weight	
	mm	in	mm	in	kg	lb
SD5/1-P	100.5	3.96	73	2.87	3.5	7.7
SD5/2-P	137.5	5.41	110	4.33	5.2	11.5
SD5/3-P	174.5	6.87	147	5.79	6.9	15.2
SD5/4-P	211.5	8.33	184	7.24	8.1	17.9

TYPE	E		F		Weight	
	mm	in	mm	in	kg	lb
SD5/5-P	248.5	9.78	221	8.70	10.1	22.3
SD5/6-P	285.5	11.24	258	10.16	11.7	25.8
SD5/7-P	322.5	12.70	295	11.61	13.2	29.1



**Parallel**

Standard configuration with side inlet and outlet and open centre (AET execution).

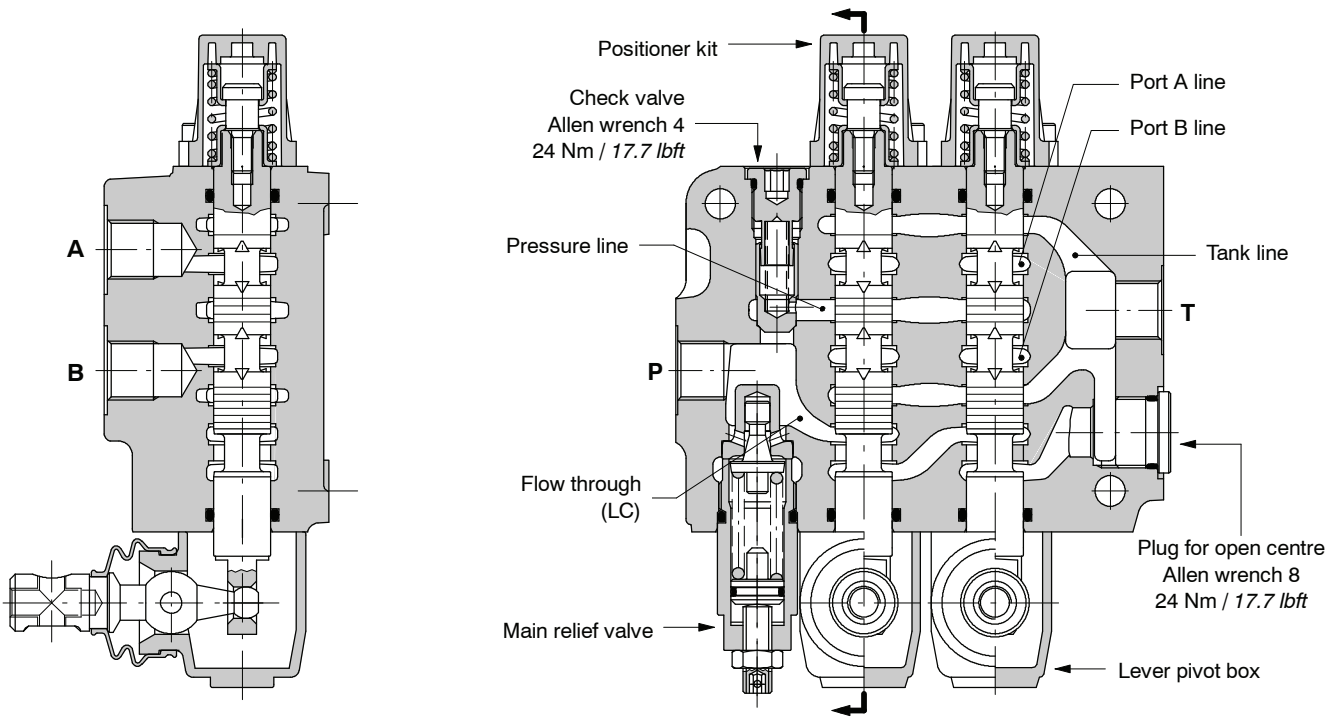

**Standard configuration**

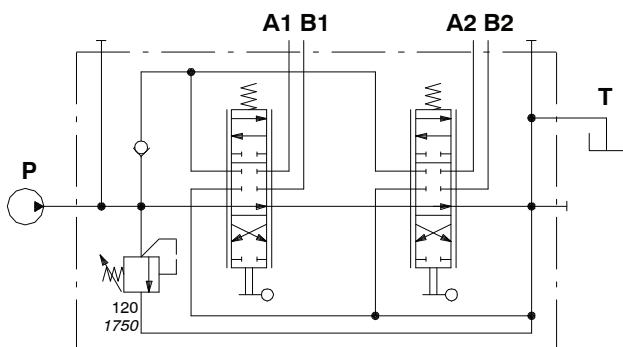

Description example  
SD5/2-P(JG3-120)/18L/18L/AET

**Configuration with upper inlet and outlet**

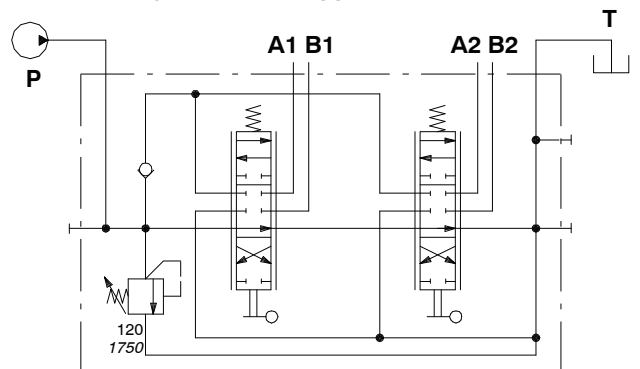

Description example:  
SD5/2-P(JG3-120)/18L/18L/AET-PSA

## Ordering codes

### Description example:

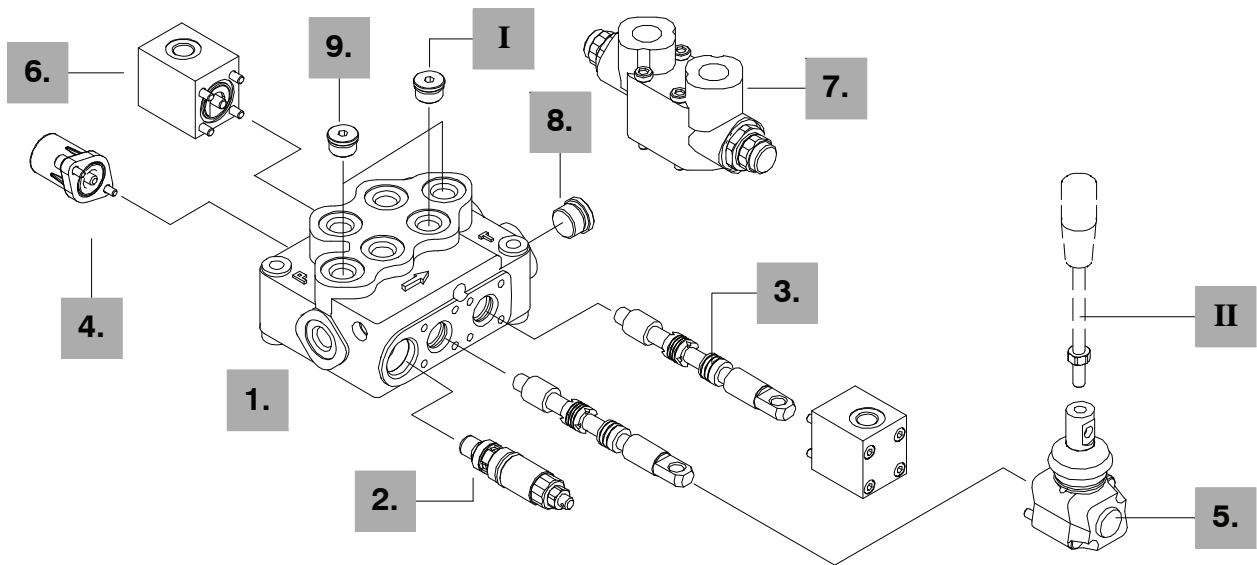
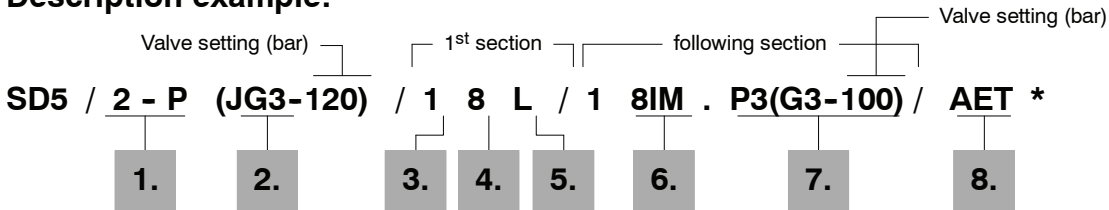

### 1. Body kits \*

TYPE	CODE	DESCRIPTION
1-P	5KC1193000	Parallel, 1 section
2-P	5KC1223000	Parallel, 2 sections
3-P	5KC1243000	Parallel, 3 sections
4-P	5KC1273000	Parallel, 4 sections
5-P	5KC1313000	Parallel, 5 sections
6-P	5KC1353000	Parallel, 6 sections
7-P	5KC13E3000	Parallel, 7 sections

Include body, seals and load check valve.

### 2. Inlet relief options page 12

TYPE	CODE	DESCRIPTION
<u>VMD5 direct pressure relief valve type J</u>		
Standard setting is referred to 10 l/min flow.		
(JG2-63)	5KIT105412	Range 40 to 63 bar / 580 to 900 psi standard setting 63 bar / 900 psi
(JG3-120)	5KIT105413	Range 50 to 200 bar / 725 to 2900 psi standard setting 120 bar / 1750 psi
(JG4-220)	5KIT105414	Range 160 to 315 bar / 2300 to 4600 psi standard setting 220 bar / 3200 psi
SV	XTAP623282	Relief valve blanking plug

### 3. Spool options page 13

TYPE	CODE	DESCRIPTION
1	3CU1210130	Double acting, 3 positions, with A and B closed in neutral position
1A	3CU1221130	Double acting, 3 positions, with A open to tank in neutral position
1B	3CU1222130	Double acting, 3 positions, with B open to tank in neutral position
2	3CU1225130	Double acting, 3 positions, with A and B open to tank in neutral position
2H	3CU1225225	Double acting, 3 positions, with A e B partially open to tank in neutral position
3	3CU1231130	Single acting on A, 3 positions, B plugged requires G3/8 plug (see part I)
<u>Special spools for particular positioner kits</u> ..... page 16		
5DY	3CU1242220	Double acting, 4 positions, floating circuit in 4 <sup>th</sup> position with spool in
5PY	3CU1245620	Double acting, 4 positions, floating circuit in 4 <sup>th</sup> position with spool out, with check valve
8	3CU1262120	Double acting, 4 positions, regenerative circuit in 4 <sup>th</sup> position with spool in
<u>Special spools for standard positioner kits</u> ..... page 19		
8F	3CU1261100	Double acting, 3 positions, regenerative circuit in 2 <sup>nd</sup> position with spool out

NOTE (\*) - Codes are referred to **BSP** threads.

**4. "A" side spool positioners page 20**

TYPE	CODE	DESCRIPTION
<b>8</b>	5V08105000	With spring return in neutral position
<b>8D</b>	5V08105200	With spring return in neutral position and pin with M6 female thread for dual control
<b>8D2</b>	5V08105220	With spring return in neutral position and pin with M8 male thread for dual control
<b>8F2</b>	5V08105101	With spring return in neutral position and adjustable flow limiter
<b>19</b>	5V19105000	2 positions, with spring return in neutral position from position 1
<b>20</b>	5V19105000	2 positions, with spring return in neutral position from position 2
<b>9</b>	5V09105010	With detent in position 1 and spring return in neutral position
<b>10</b>	5V10105010	With detent in position 2 and spring return in neutral position
<b>11</b>	5V11105000	Detent in positions neutral, 1 and 2
<b>12</b>	5V12105000	Detent in positions 1 and 2
<b>15</b>	5V15105000	2 positions, detent in positions 1 and neutral
<b>16</b>	5V16105000	2 positions, detent in positions 2 and neutral
<b>9BZ</b>	5V09202010	With detent in position 1 and spring return in neutral position
<b>10BZ</b>	5V10202010	With detent in position 2 and spring return in neutral position
<b>11BZ</b>	5V11202010	Detent in positions 1 and 2 and spring return in neutral position
<b>8K</b>	5V08705112	With spring return in neutral position and 12 VDC spool solenoid lock device
	5V08705124	As previous, 24VDC
<b>8RM2</b>	5V08105590	With spring return in neutral position and 12VDC electromagnetic detent in pos. 2
	5V08105595	As previous, 24VDC
<b>8MHE3(NO)</b>	5V08105541	With spring return in neutral position and spool positioning ON/OFF electric signal circuit normally closed
<b>8MHE3(NO)</b>	5V08105540	As previous, with circuit normally open
<b>8MS3</b>	5V08105553	With spring return in neutral position, operation signalling in position 1 and 2, prearranged for centralized microswitch control: need KM connection kit
<b>8MG3(NO)</b>	5V08105660	With spring return in neutral position and microswitch in positions 1 and 2
<b>8P</b>	5V08105701	ON/OFF pneumatic kit
<b>8EP3</b>	5V08105735	ON/OFF 12 VDC electro-pneumatic kit
	5V08105740	ON/OFF 24 VDC electro-pneumatic kit
<b>8ED3</b>	5V08105350	ON/OFF 12 VDC electro-hydraulic kit
	5V08105351	ON/OFF 24 VDC electro-hydraulic kit

**I "A" and "B" ports plugs \***

TYPE	CODE	DESCRIPTION
<b>G3/8</b>	3XTAP722160	for single acting spool type 3

**4. "A" side spool positioners**

Particular positioner kits for special spools ..... page 36

<b>13NZ</b>	5V13305010	4 pos. with spring return in neutral pos. and detent in 4 <sup>th</sup> pos.: <b>for spool 5DY</b>
<b>13QN</b>	5V13405020	4 pos. with spring return in neutral pos. and detent in 4 <sup>th</sup> pos.: <b>for spool 5PY</b>
<b>13FZ</b>	5V13505400	4 positions with spring return in neutral position: <b>for spool 8</b>
<b>13QNMG3(NO)</b>	5V13405660	As type 13QN with microswitch in positions 1 and 2: <b>for spool 5PY</b>

**5. "B" side options page 39**

TYPE	CODE	DESCRIPTION
<b>L</b>	5LEV105000	Standard lever box
<b>LM10</b>	5LEV205000	Lever box for M10 handlever
<b>LF1</b>	5LEV105102	Lever box with adjustable flow limiter
<b>LEB</b>	5LEV605000	Safety lever box, vertical configuration
<b>LUP</b>	5LEV805005	Safety lever box, horizontal configuration
<b>SLP</b>	5COP105000	Without lever box, with dust-proof plate
<b>SLC</b>	5COP205000	Without lever box, with endcap
<b>TQ</b>	5TEL105110	Flexible cable connection
<b>LCB</b>	5CLO205100	Joystick lever for 2 sections operation

**6. Complete controls page 44**

Proportional hydraulic control type **8IM** and ON/OFF solenoid controls type **8ES** and **8ESN**.

**7. Service valves page 52**

Port relief, anti-shock, pilot operated check and flow regulation valves.

**8. Outlet port option page 49**

TYPE	CODE	DESCRIPTION
<b>AET</b>	XTAP623170	Open centre plug
<b>AEK</b>	3XTAP522282	Closed centre plug
<b>AE</b>	3XGIU522460*	G3/8 carry-over sleeve
<b>AET-L</b>	XCAR405300	With hydraulic pilot unloader valve
<b>AET-LT</b>	XTAP523370	Unloader valve blanking plug

**Electric control unloader valve:** for valves and coils list see page 50.

**9. Inlet and outlet selection \* page 9**

TYPE	CODE	DESCRIPTION
<b>PSL</b>	3XTAP722160	Side ports; need n.2 G 3/8 plugs, standard configuration (omit in valve description)
<b>PSA</b>	3XTAP722160	Upper ports; need n.2 G 3/8 plugs

**II Optional handlevers**

TYPE	CODE	DESCRIPTION
<b>AL01/M8x120</b>	170011012	For lever L: height 120 mm / 4.72 in
<b>AL01/M10x150</b>	170012015	For lever LM10: height 150 mm / 5.91 in
<b>AL08/M12x150</b>	170013115	For joystick LCB: height 150 mm / 5.91 in

Inlet relief options

Direct pressure relief vave

VMD5 ( J G 3 - 120 )

- Standard setting in bar (for value see page 8)
- Adjustable spring type (2, 3, 4).
- Adjustment type (G, H)

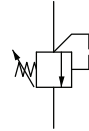

Adjustment type

G: with screw

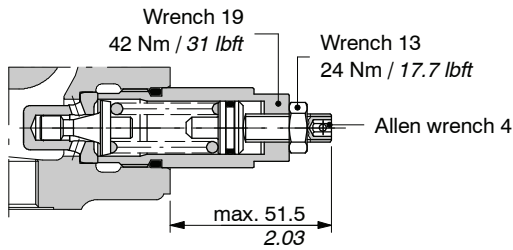

H: valve set and locked

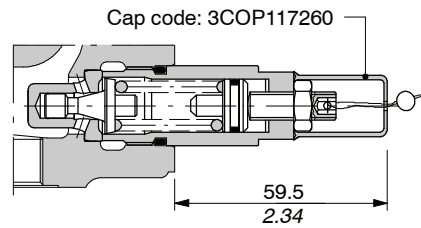

Performance data

Spring nr. 2 (green band)

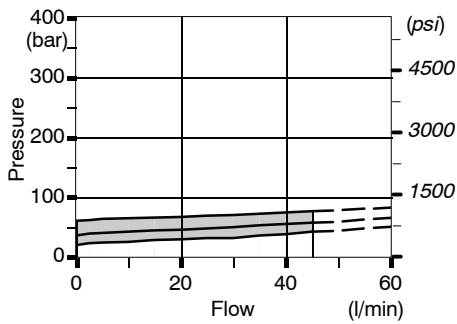

Spring nr. 3 (blue band)

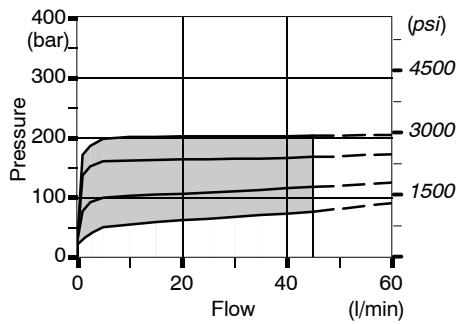

Spring nr. 4 (red band)

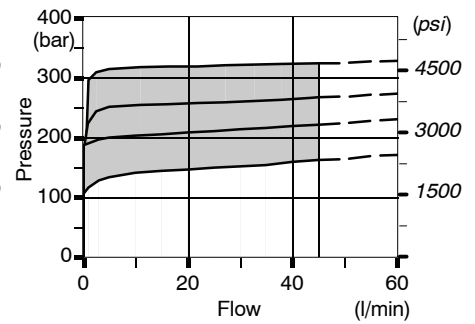

SV: relief valve blanking plug

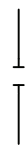
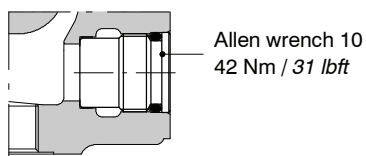

Time response

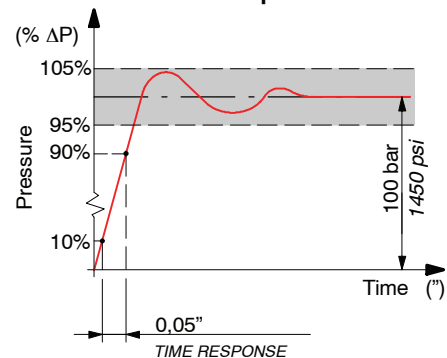

Type 1

For special requirement, spool 1CS code 3CU1210200 suggested for flow from 15 to 30 l/min and spool 1CEX code 3CU1210230 suggested for flow up to 15 l/min, are available.

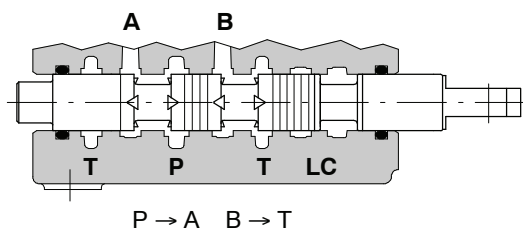

stroke:  
+ 5.5 mm / 0.22 in

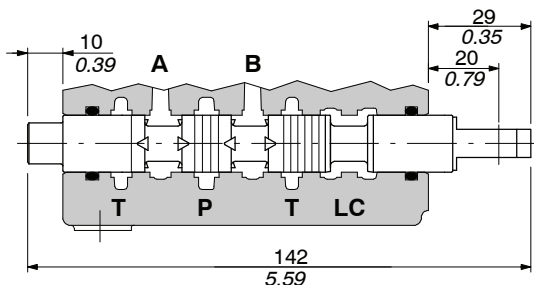
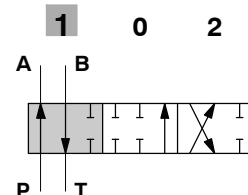

P-A-B-T closed, with flow through line (LC) open

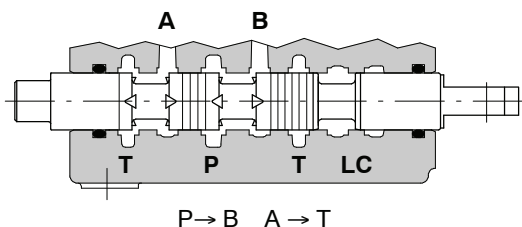
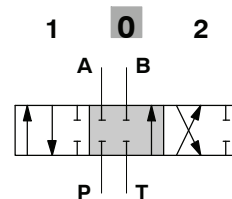

stroke:  
+ 5.5 mm / 0.22 in

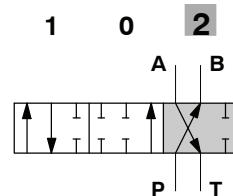

Performance data

Spool metering P→A(B)

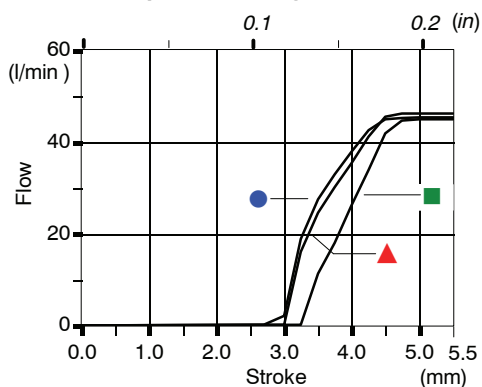

Q<sub>in</sub> = 45 l/min

- P (on ports) = 63bar / 900 psi
- ▲ P (on ports) = 100bar / 1450 psi
- P (on ports) = 250bar / 3600 psi

Spool metering A(B)→T

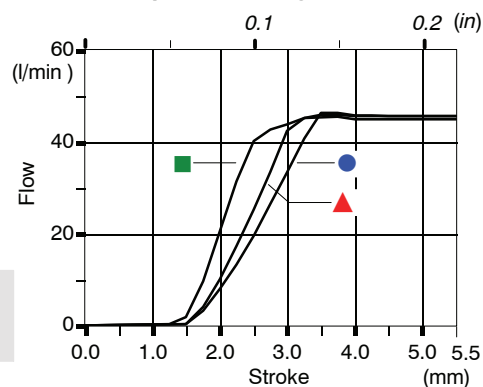

## Spool options

## Type 1A

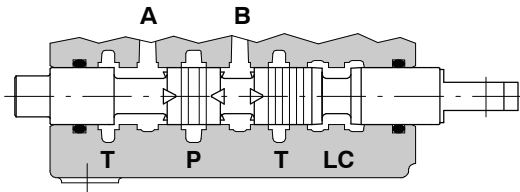

P-B closed, A→T, flow through line (LC) open

+ 5,5 mm / 0.22 in  
 (1) ▶  
 ◀▶ (0)  
 ◀ (2)  
 - 5,5 mm / 0.22 in

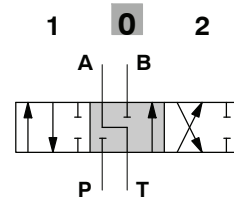

## Type 1B

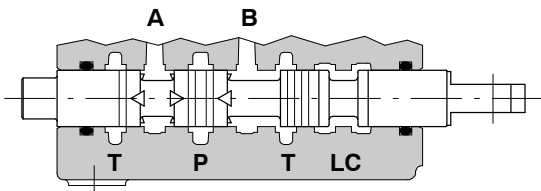

P-A closed, B→T, flow through line (LC) open

+ 5,5 mm / 0.22 in  
 (1) ▶  
 ◀▶ (0)  
 ◀ (2)  
 - 5,5 mm / 0.22 in

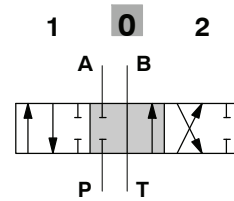

## Type 2

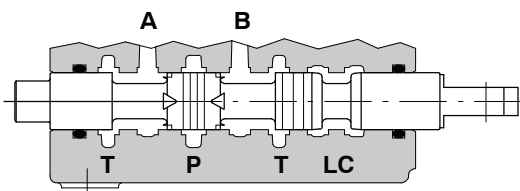

P closed, A-B→T, flow through line (LC) open

+ 5,5 mm / 0.22 in  
 (1) ▶  
 ◀▶ (0)  
 ◀ (2)  
 - 5,5 mm / 0.22 in

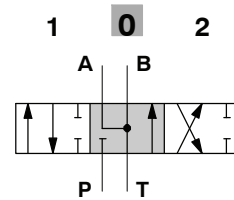

## Type 2H

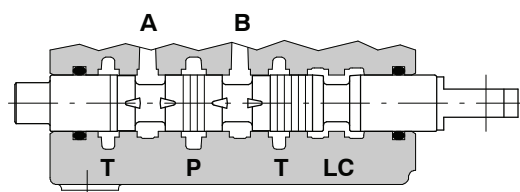

P closed, A-B partially open to tank,  
 flow through line (LC) open

+ 5,5 mm / 0.22 in  
 (1) ▶  
 ◀▶ (0)  
 ◀ (2)  
 - 5,5 mm / 0.22 in

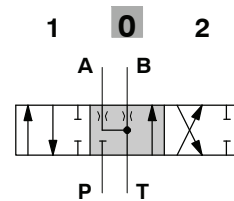

Type 3

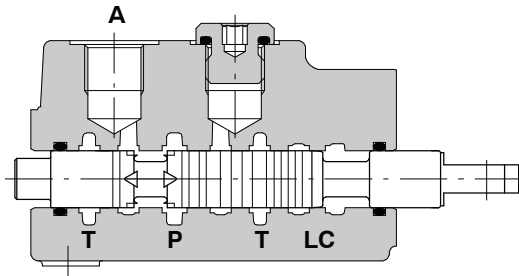

stroke:  
+ 5.5 mm / 0.22 in

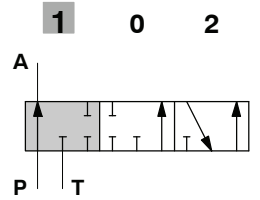

P → A

Port B plugged  
Allen wrench 6 - 24 Nm / 17.7 lbf

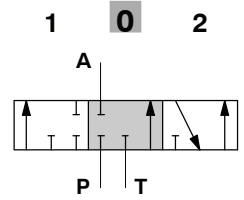
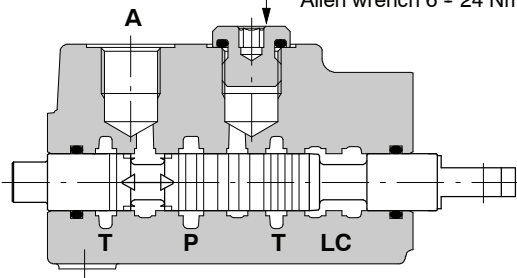

P-B-T closed, flow through line (LC) open

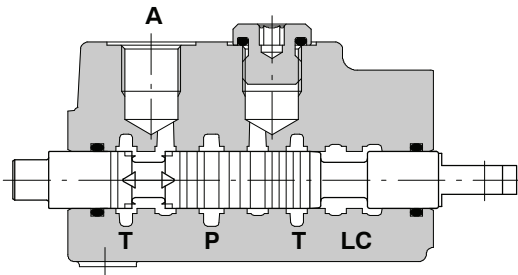

stroke:  
- 5.5 mm / 0.22 in

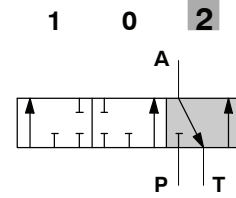

A → T

Performance data

Spool metering P→A

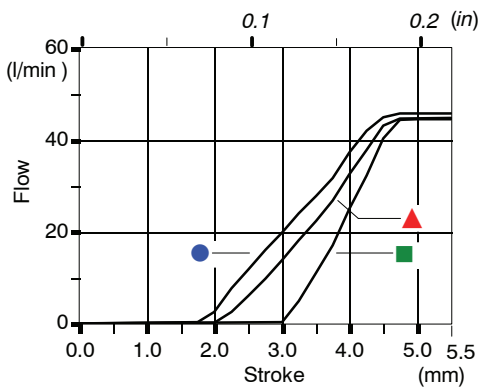

Qin = 45 l/min

- P(on ports) = 63bar / 900 psi
- ▲ P(on ports) = 100bar / 1450 psi
- P(on ports) = 250bar / 3600 psi

Spool metering A→T

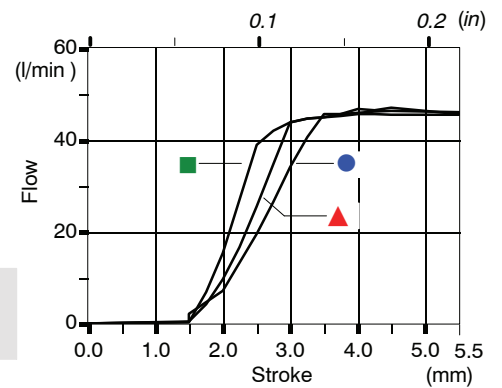

Spools

Type 5DY

It needs special body with extra machining: for information please contact Sales Department.

This spool must be coupled with positioner type 13NZ (see page 36).

Also available spool with check valve on A port; type 5WY code 3CU1242320.

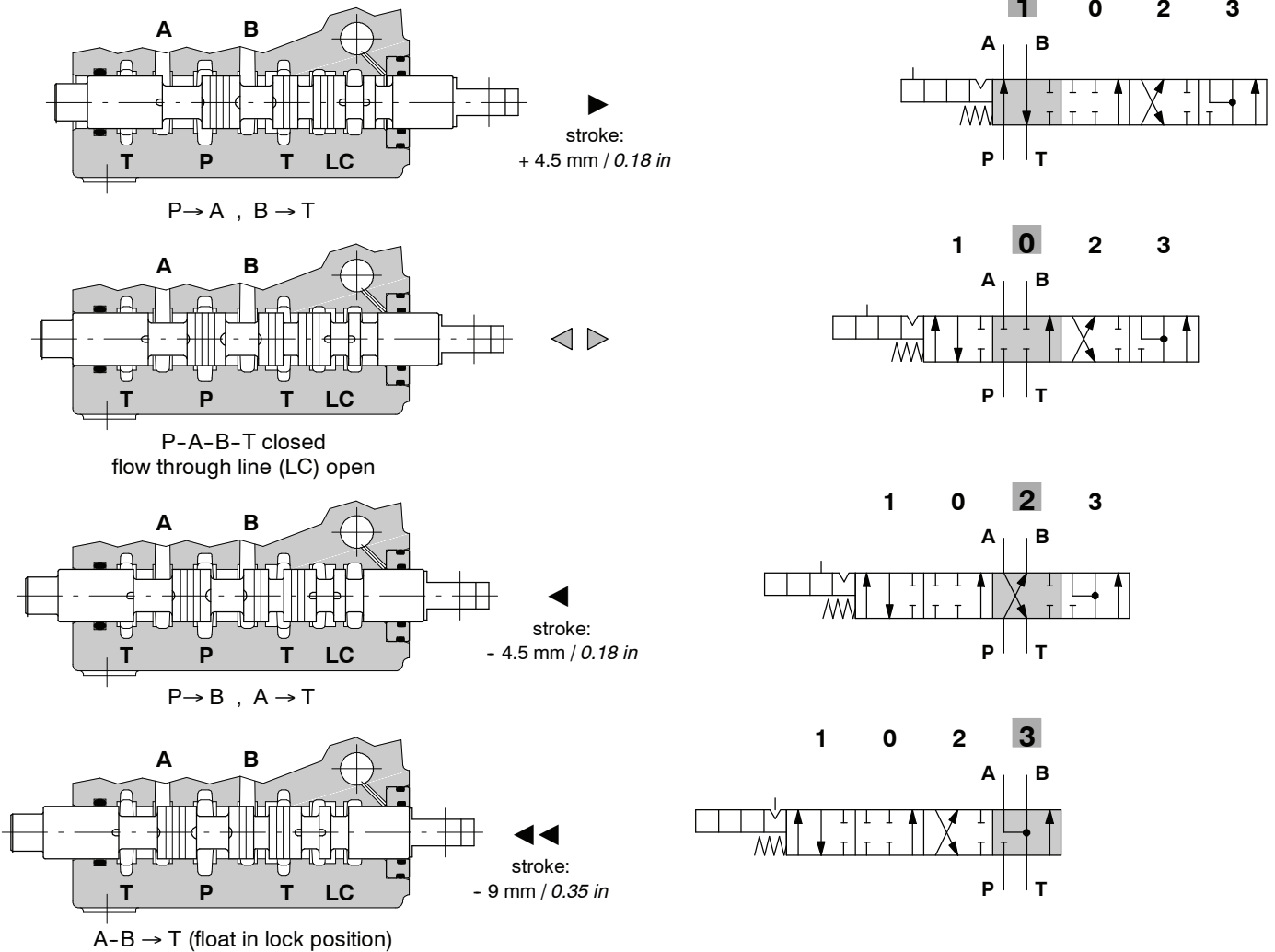

Performance data

Spool metering

Q<sub>in</sub> = 45 l/min / P<sub>(on ports)</sub> = 100 bar - 1450 psi  
0.1 0.2 (in)

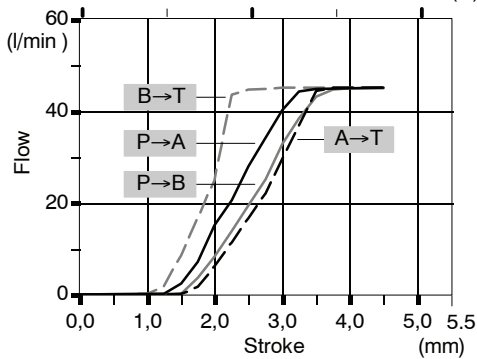

Pressure drop in position 3

(last section)

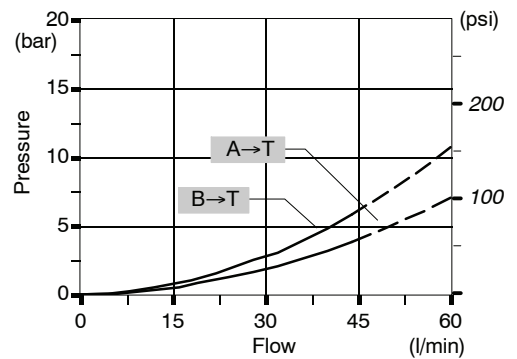



**Type 5PY**

It needs special body with extra machining: for information please contact Sales Department.

This spool must be coupled with positioner type **13QN** (see page 36) and **13QNMG3** (see page 37).

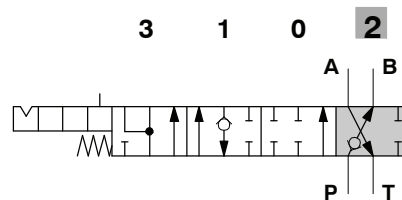
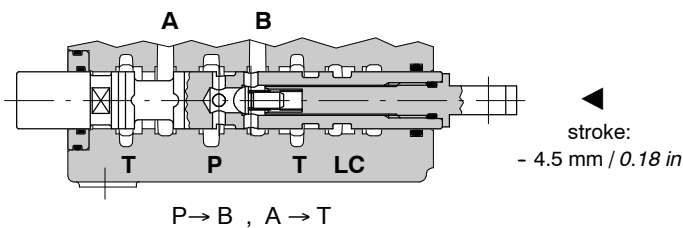
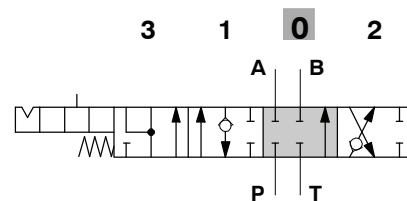
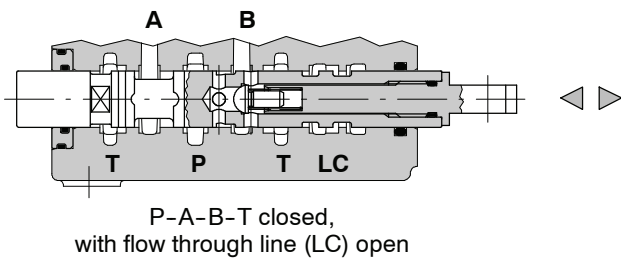
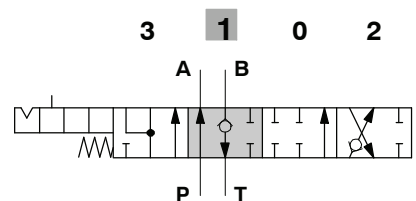
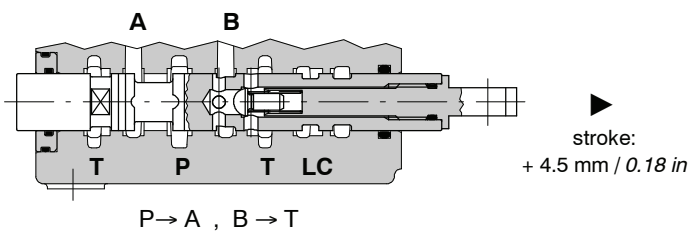
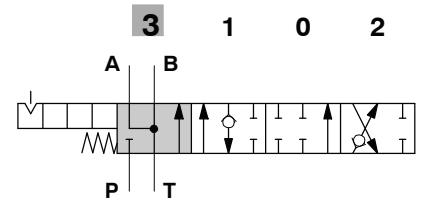
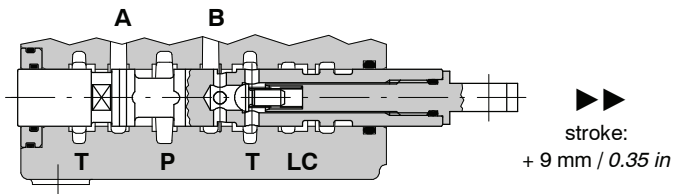

**Performance data**

**Spool metering**

$Q_{in} = 45 \text{ l/min} / P_{(on ports)} = 100 \text{ bar} - 1450 \text{ psi}$   
0.1 0.2 (in)

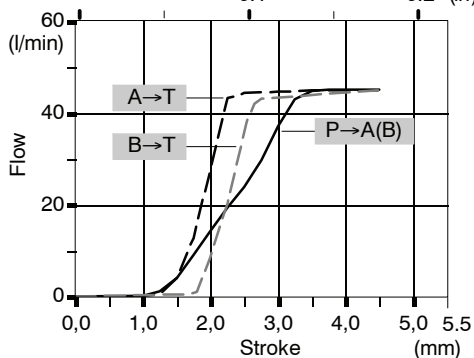

**Pressure drop in position 3**

(last section)

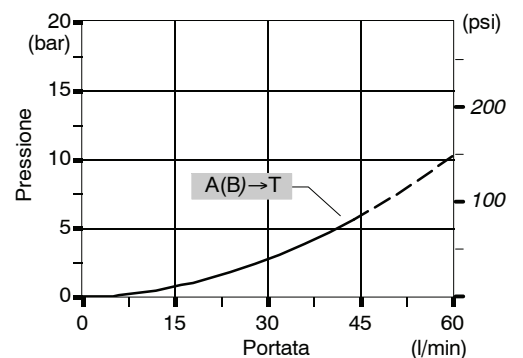

Spools

Type 8

It needs special body with extra machining: for information please contact Sales Department.

This spool must be coupled with positioner type 13FZ (see page 37).

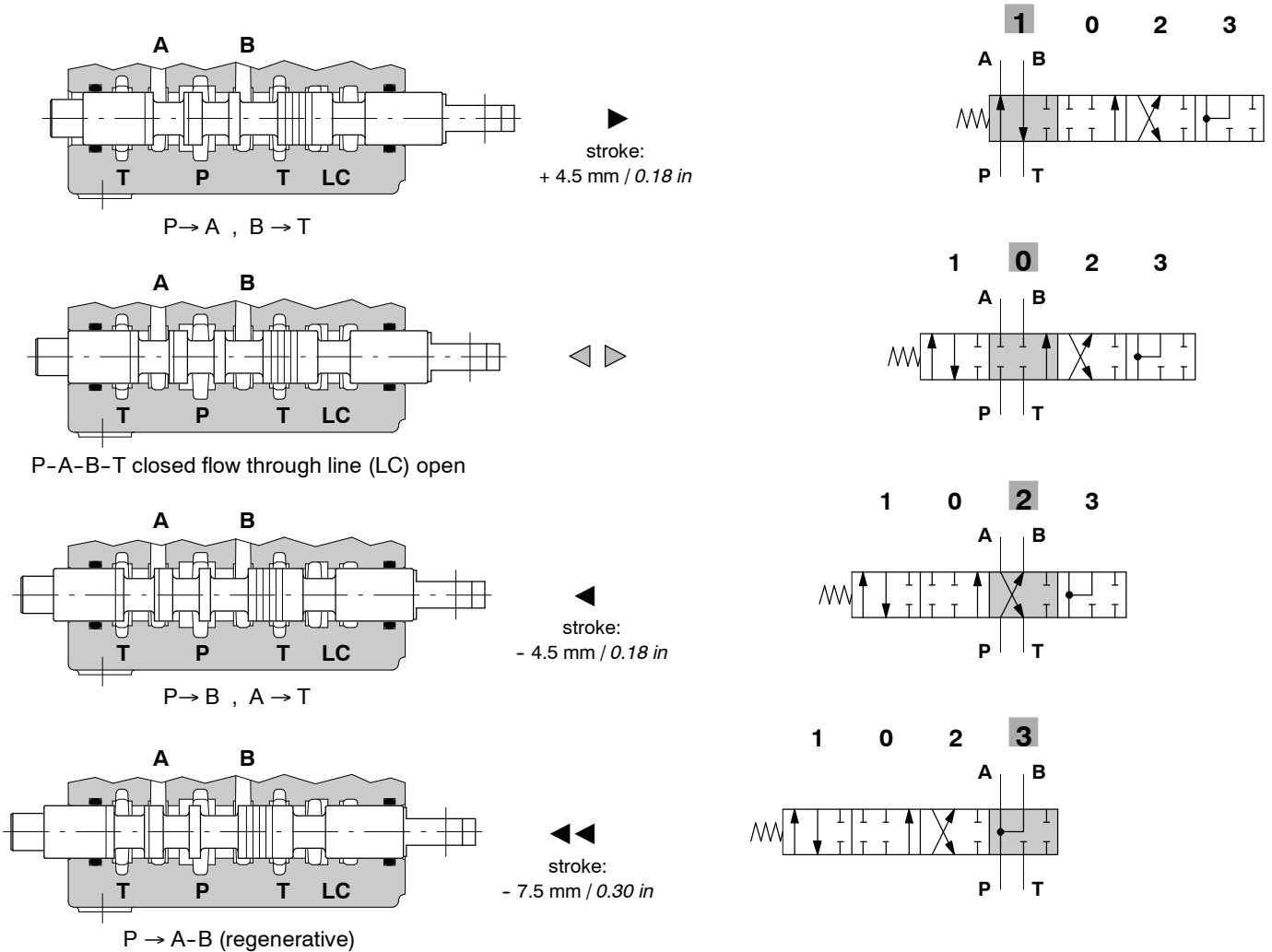

Performance data

Spool metering

$Q_{in} = 45 \text{ l/min} / P_{(on ports)} = 100 \text{ bar} - 1450 \text{ psi}$   
 0.1 0.2 (in)

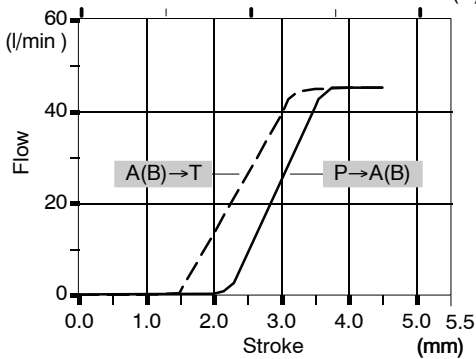

Pressure drop in position 3

(last section)

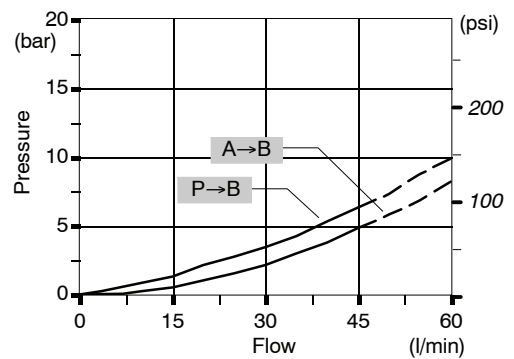

Type 8F

It needs special body with extra machining: for information please contact Sales Department.

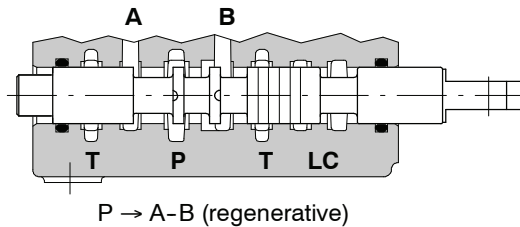

stroke:  
+ 5.5 mm / 0.22 in

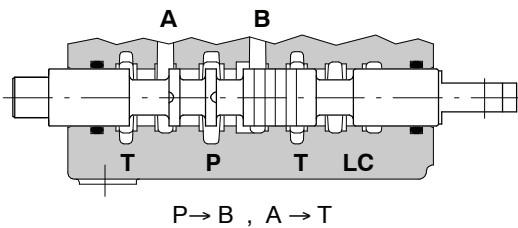
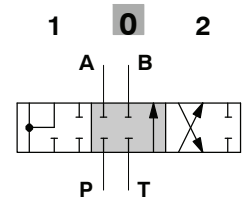
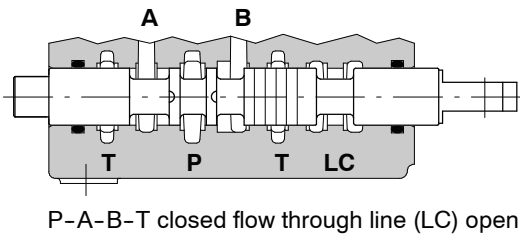
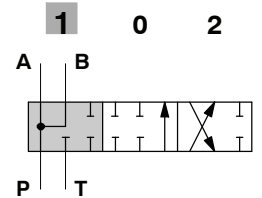

stroke:  
- 5.5 mm / 0.22 in

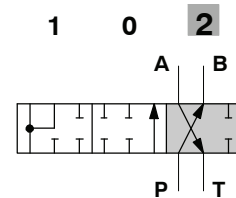

Performance data

Spool metering

$Q_{in} = 45 \text{ l/min} / P_{(on ports)} = 100 \text{ bar} - 1450 \text{ psi}$   
0.1 0.2 (in)

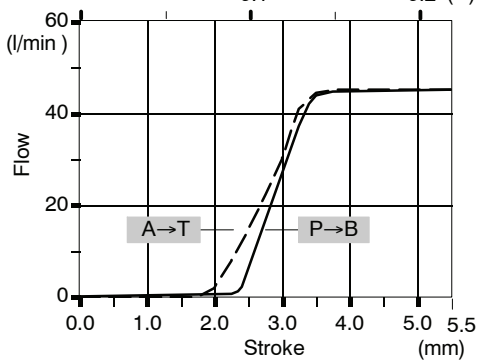

Pressure drop in position 1

(in first section)

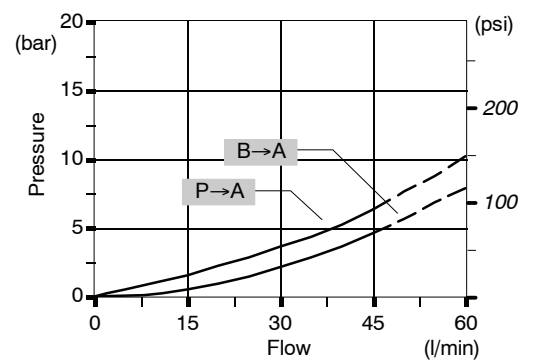

"A" side spool positioners

With spring return in neutral position

8 kit

It's supplied with standard spring type D (see force-stroke diagram) and available with lighter spring type C (8MC code: 5V08205000) or heavier type E (8ME code: 5V08405000).

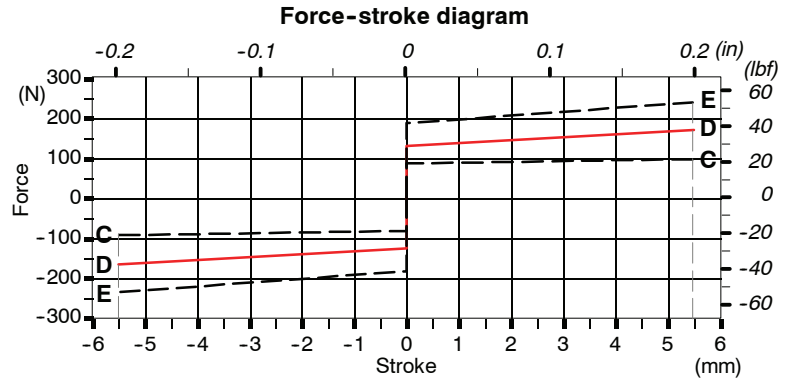
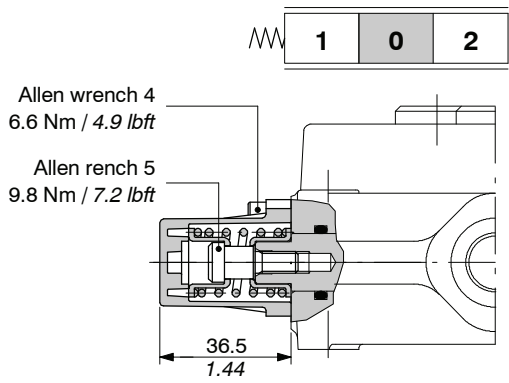

8D kit

Spool end joint code XPER315400, is available on request in order to screw onto pin.

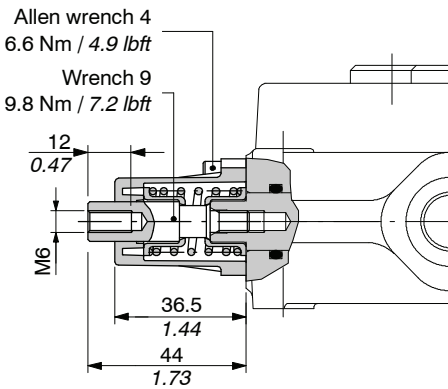

Spool end joint dimensions

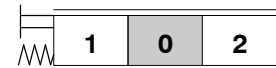
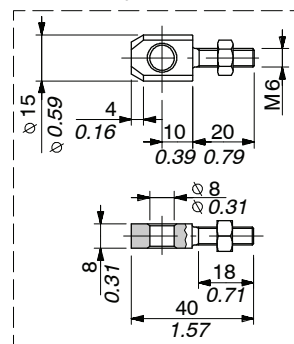

8D2 kit

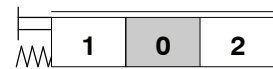
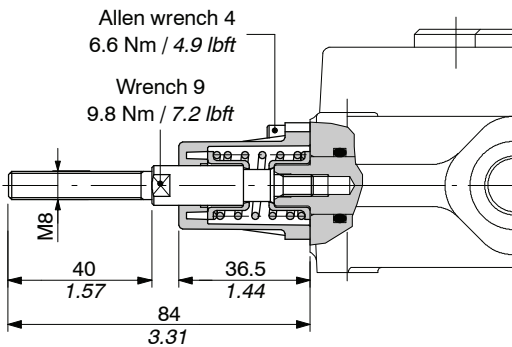

With spring return in neutral position

8F2 kit

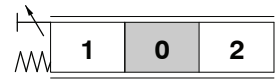
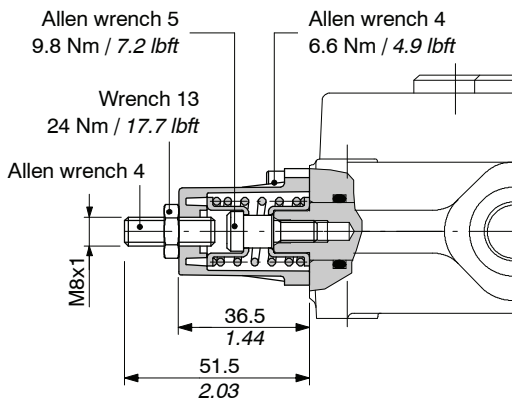

19 kit

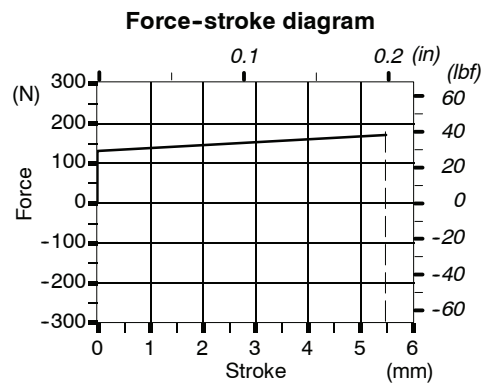
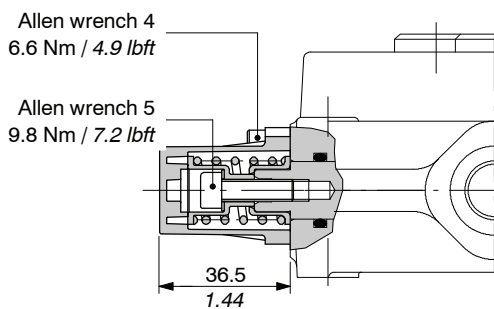
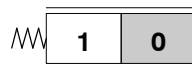

20 kit

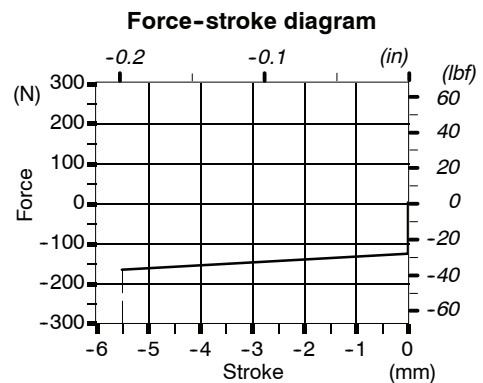
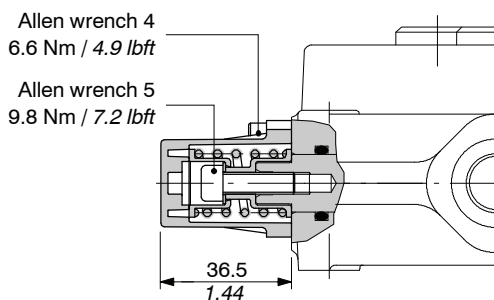
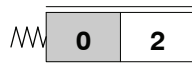

"A" side spool positioners

With detent

9 kit

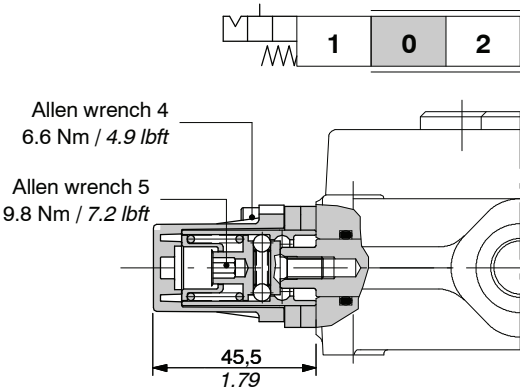

Operating features

Locking force (from pos. 0 to 1) . . . : 150 N / 33.7 lbf ±10%  
 Release force (from pos. 1 to 0) . . . : 140 N / 31.5 lbf ±10%

10 kit

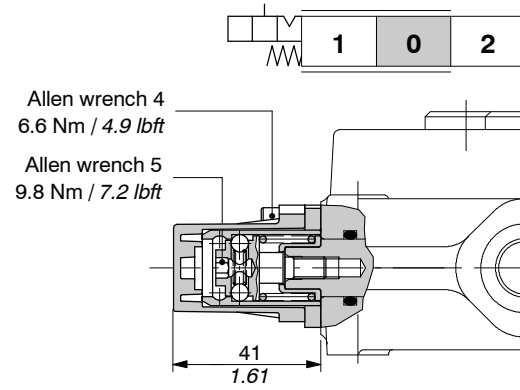

Operating features

Locking force (from pos. 0 to 2) . . . : 150 N / 33.7 lbf ±10%  
 Release force (from pos. 2 to 0) . . . : 140 N / 31.5 lbf ±10%

11 kit

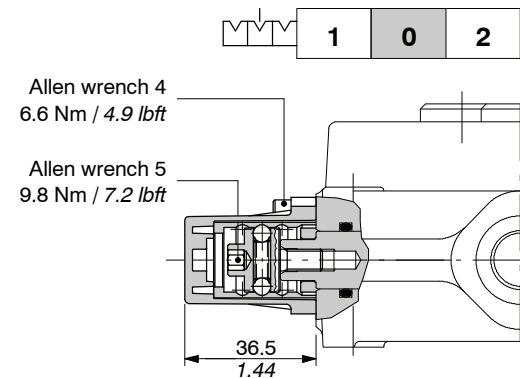

Operating features

Locking and release force . . . . . : 120 N / 27 lbf ±10%

12 kit

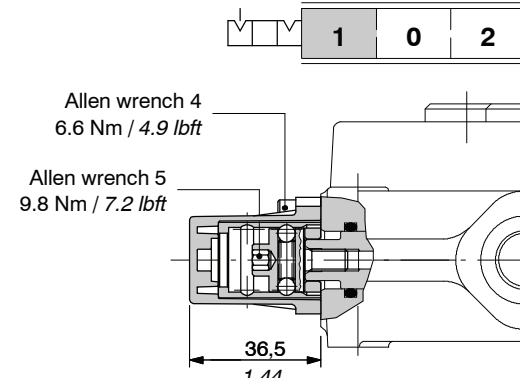

Operating features

Locking and release force . . . . . : 100 N / 22.5 lbf ±10%

15 kit

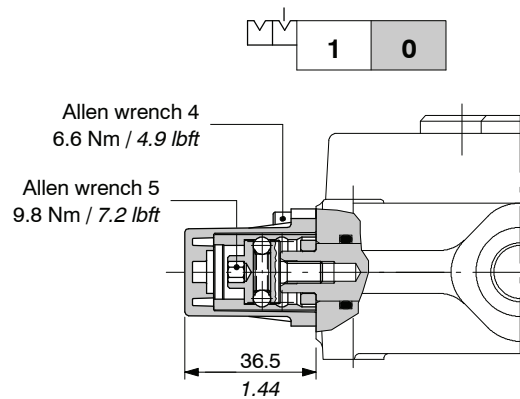

Operating features

Locking and release force . . . . . : 100 N / 22.5 lbf ±10%

16 kit

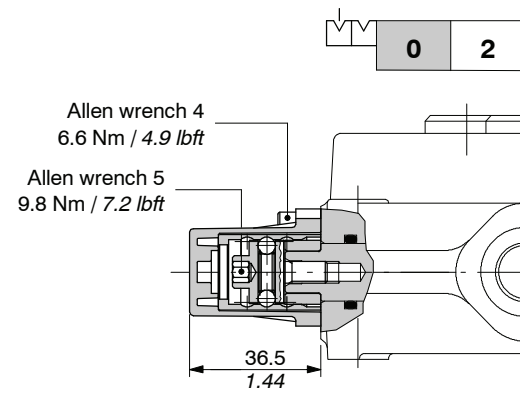

Operating features

Locking and release force . . . . . : 100 N / 22.5 lbf ±10%

With detent and spring return to neutral position from either directions

9BZ kit

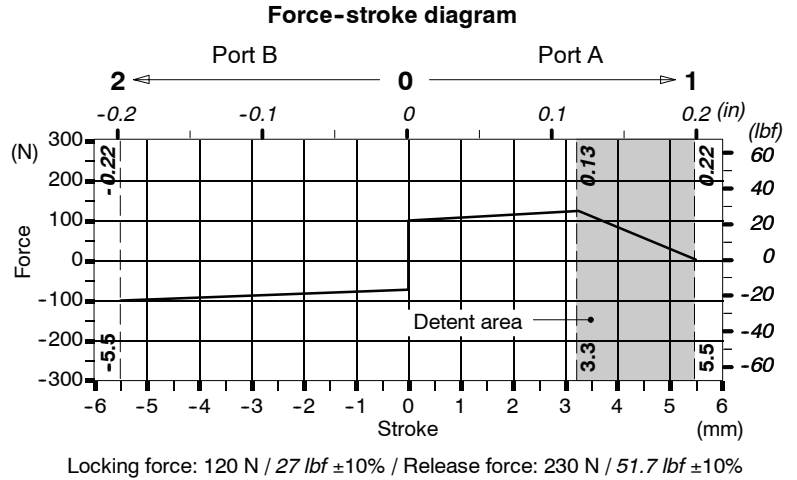
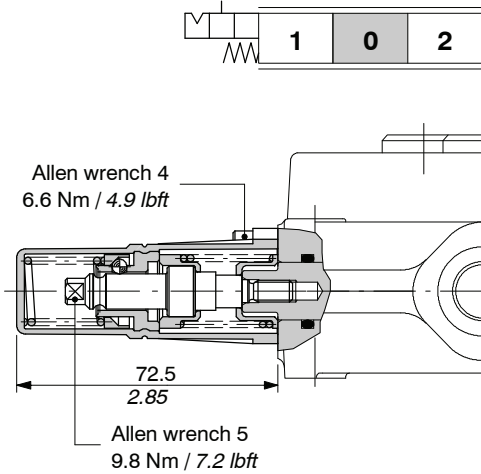

10BZ kit

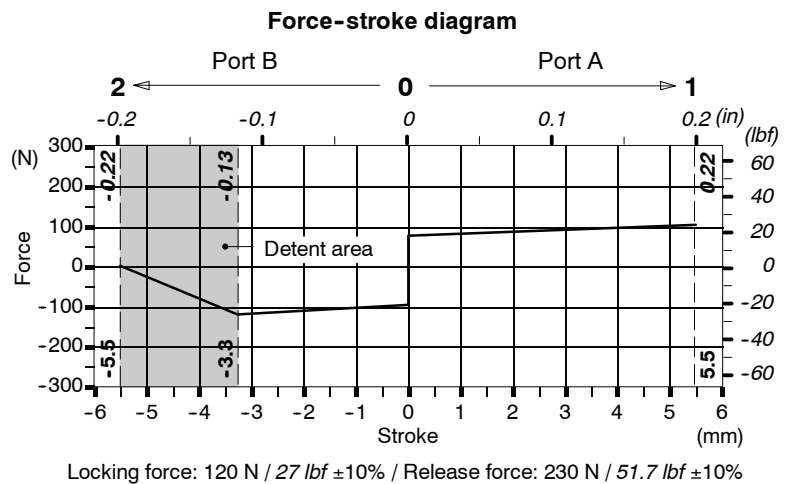
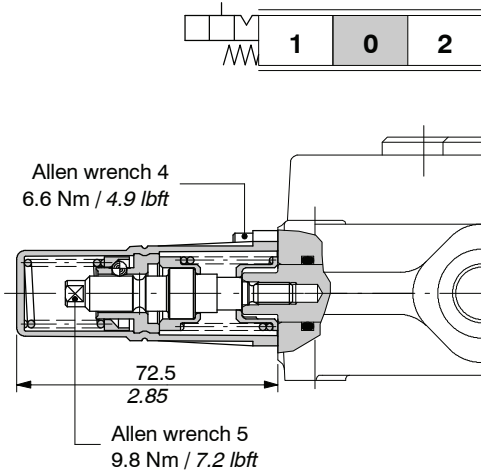

11BZ kit

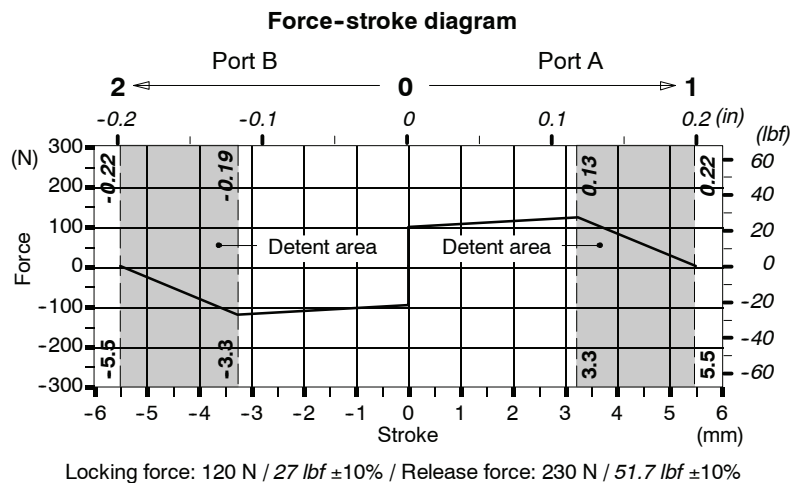
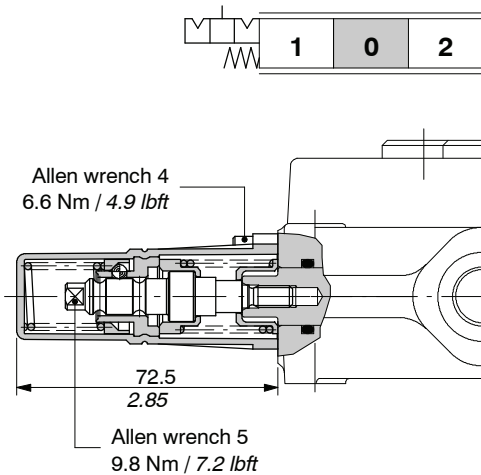

“A” side spool positioners

Solenoid lock device type 8K

With spring return and spool electromechanical lock in neutral position; when coil is feeded the spool can be moved.

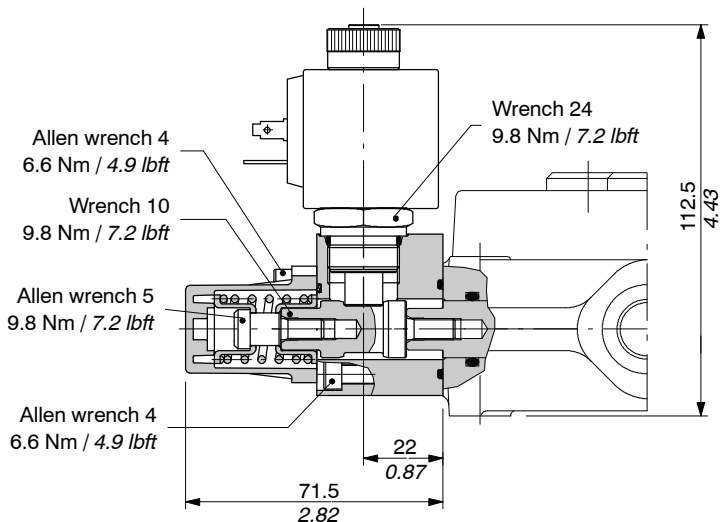
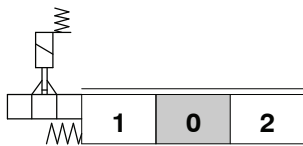

NOTE - The kit control must be turned at 180°. when pilot operated check valves are fitted.

COMPLETE CONTROLS CODES

Voltage	CONNECTION TYPE		
	ISO4400	Deutsch DT	Packard M-Pack
	CONTROL TYPE		
	8K	8K4	8K6
12 VDC	5V08705112	5V08705412	5V08705612
24 VDC	5V08705124	5V08705424	5V08705624
Need connector (see page 129)	C02	C19	C20

Operating features

ACTUATOR

Lock stroke ..... : 3.5 mm / 0.14 in

COIL

Depending on model: see following features

Coil with ISO4400 connector

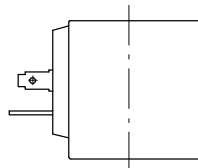

Nom. voltage tolerance ..... : ±10%  
 Power rating ..... : 18 W  
 Nominal current ..... : 1.58 A - 12 VDC  
 : 0.81 A - 24VDC  
 Coil insulation ..... : Class F  
 Weather protection ..... : IP65  
 Duty cycle ..... : 100%

Coil with Deutsch DT connector

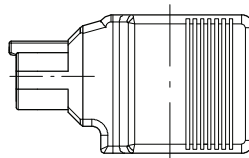

Nom. voltage tolerance ..... : ±10%  
 Power rating ..... : 22 W  
 Nominal current ..... : 1.9 A - 12 VDC  
 : 0.95 A - 24VDC  
 Coil insulation ..... : Class H  
 Weather protection ..... : IP65  
 Duty cycle ..... : 100%

Coil with Packard M-Pack connector

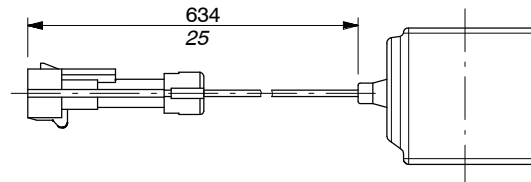

Nom. voltage tolerance ..... : ±10%  
 Power rating ..... : 18 W  
 Nominal current ..... : 1.58 A - 12 VDC  
 : 0.81 A - 24VDC  
 Coil insulation ..... : Class F  
 Weather protection ..... : IP65  
 Duty cycle ..... : 100%



“A” side spool positioner

Solenoid lock device type 8K

More configurations and spare parts

It's possible to obtain further configurations of complete control, using the K kit, coils and 3 positions “A” side spool positioner, as following draw: for information contact Sales Department.

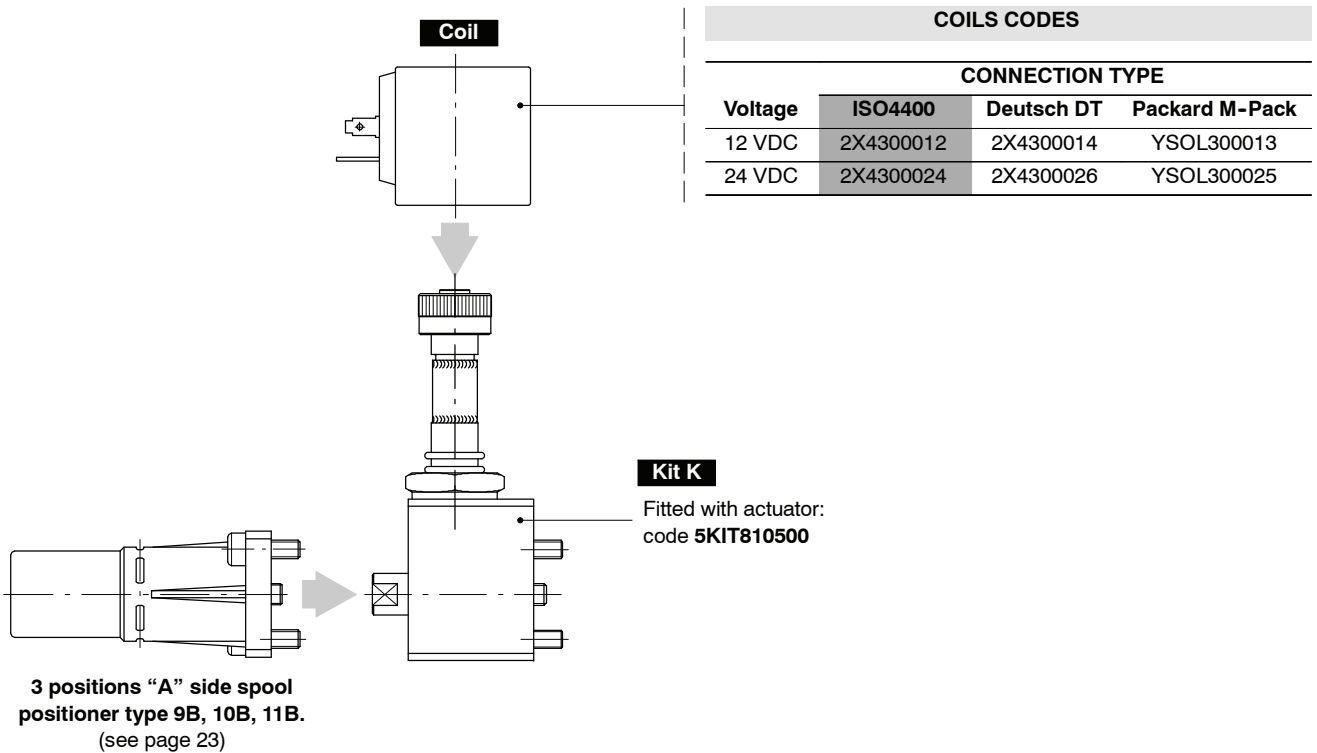

“A” side spool positioners

Electromagnetic detent type 8RM2

With electromagnetic detent in position 2 and spring return to neutral position.

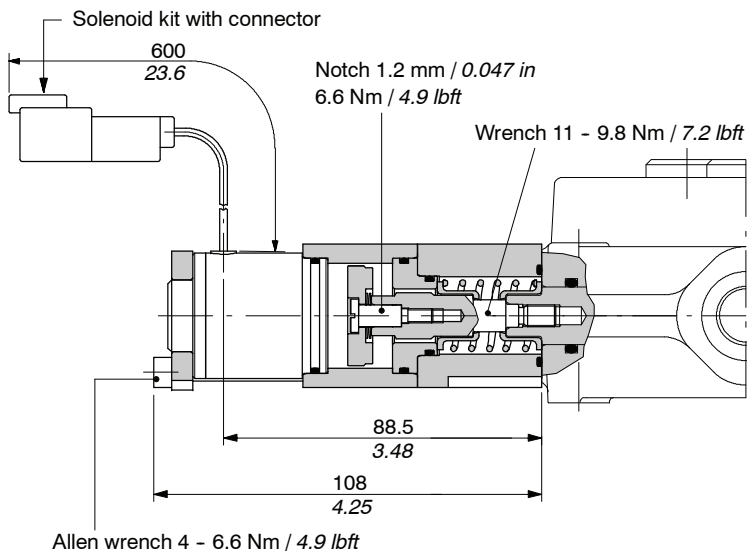
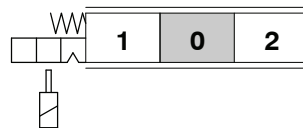

Operating features

- COIL**
- Nominal voltage : 12 / 24 VDC ± 10%
  - Power rating : 5,5 W
  - Resistance (20 °C) : 26,5 / ??? Ohm
  - Min unlocking force : 45 N / 49.5 lbf
  - Duty cycle : 100%

COMPLETE CONTROLS CODES

	CONNECTION TYPE		
	Deutsch DT	AMP	Packard M-Pack
	CONTROL DESCRIPTION		
<b>Voltage</b>	<b>8RM2</b>	<b>8RM2A(200)</b>	
12 VDC	5V08105590	5V08105591	5V08105593
24 VDC	5V08105595	5V08105596	5V08105598
<b>Need connector</b> (see page 129)	C19	C21	C20

COILS CODES

Voltage	CONNECTION TYPE		
	Deutsch DT	AMP	Packard M-Pack
12 VDC	YSOL532455	YSOL532452	YSOL532451
24 VDC	YSOL532456	YSOL532458	YSOL532457

Coil with Deutsch DT connection

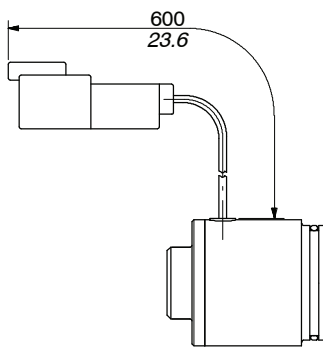

Coil with AMP Fastin-Faston connection

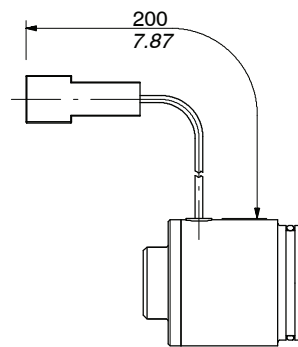

Coil with Packard M-Pack connection

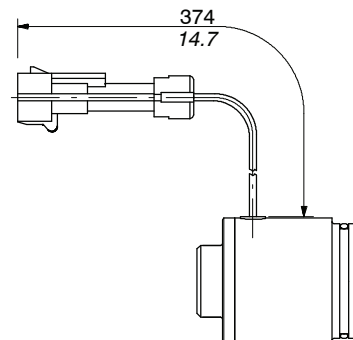

**8MHE3 kit: with spring return in neutral position and spool positioning ON/OFF signal**

This module supplies two different ON/OFF signals, related to the direction of the spool.  
It has two separate contacts which can be normally open or normally closed.

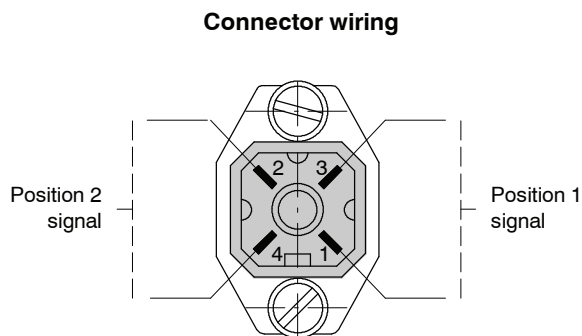
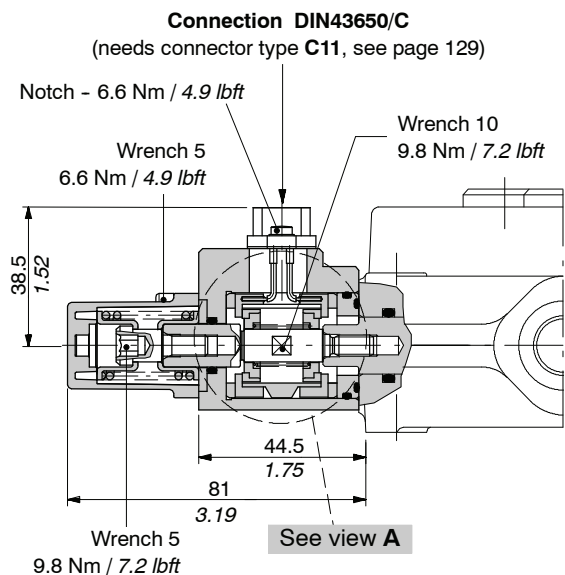

**Operating features**

- Power supply range : from 3 da 28 VDC
- Max. output current : 500 mA
- Weather protection : IP65

**8MHE3(NC) kit**

Configuration with normally closed circuit

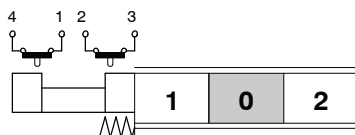

View A

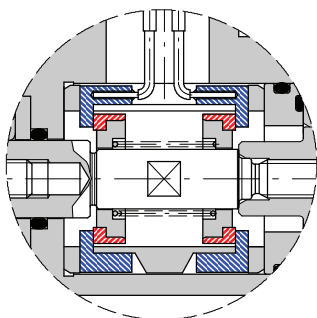

Mobile contact  
Fixed contact

**Output signal with NC circuit**

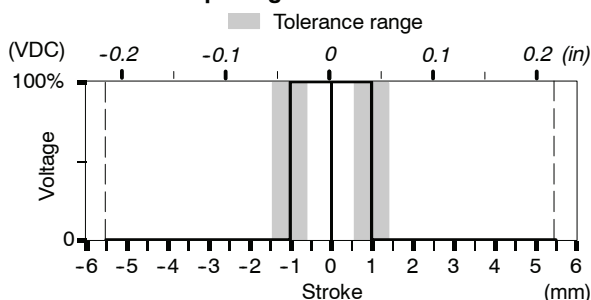

**8MHE3(NO) kit**

Configuration with normally open circuit

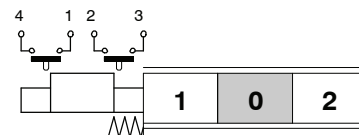

View A

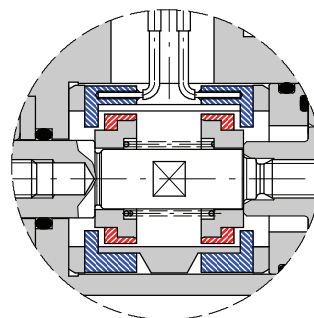

Mobile contact  
Fixed contact

**Output signal with NO circuit**

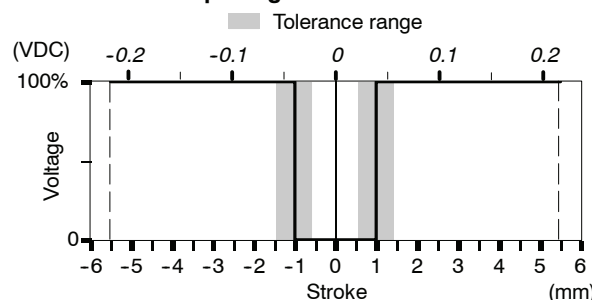

"A" side spool positioners

8MS3 kit: with centralized control for microswitch

Assembly example

It's shown an assembling on 2 section directional control valve, complete with connection kit KM.

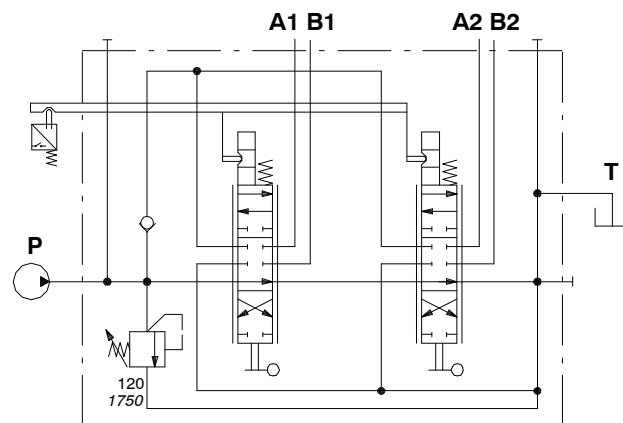
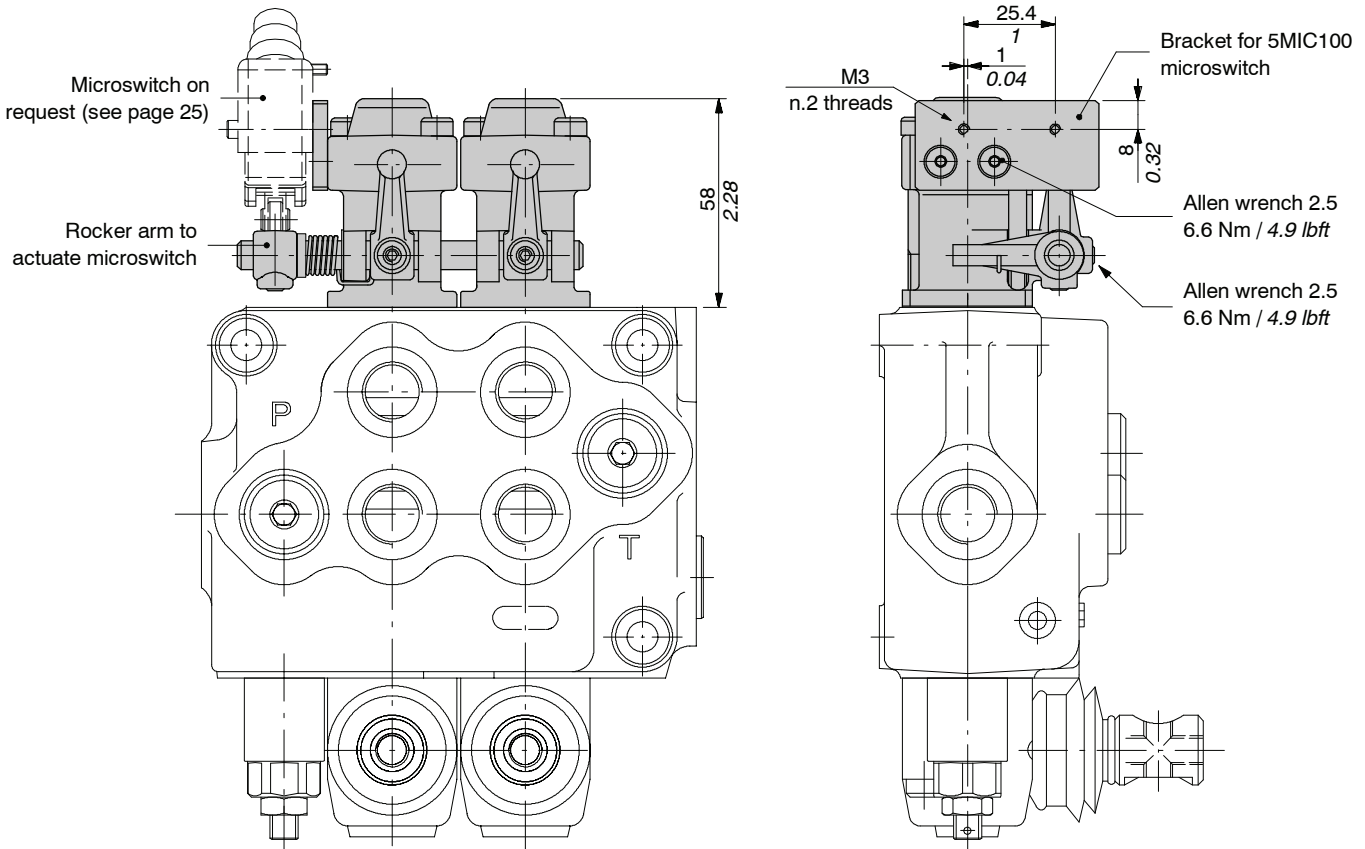

Es.: SD5/2-P(JG3-120)/18MS3L/18MS3L/AET - KM 2 S 51

- Assembling kit
  - 51 = with bracket for M51 (IP51) microswitch fixing
  - 67 = with bracket for M67 (IP67) microswitch fixing
- Nr. of working sections
  - S = bracket placed on left
  - D = bracket placed on right

**8MS3 kit: with centralized control for microswitch**

The spool positioner is composed of actioning pin 1, bushes 2 and return spring 3.  
The remaining items (cap, rocker arm, bracket, rod ecc..) are components of KM connection kit, which depends on nr of controlled section.

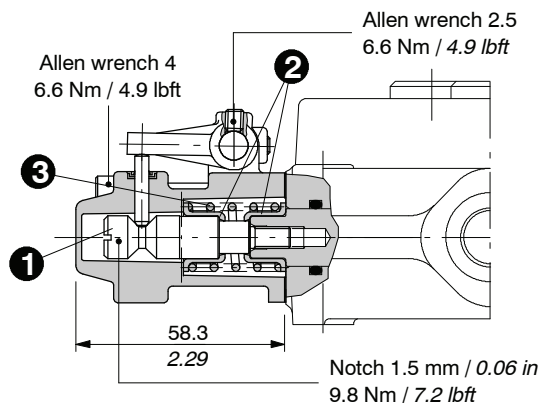

**8MS3 kit**  
microswitch operation in positions 1 and 2

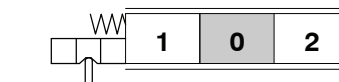

**Other configurations**

**8MS1 kit**  
microswitch operation in position 1

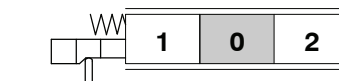

**8MS2 kit**  
microswitch operation in position 2

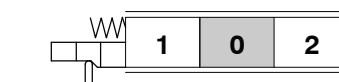

**KM kit ordering codes**

The codes below represent the kit with bracket for IP51 microswitch, assembled on the left

For other codes or information contact Sales Department.

TYPE	CODE	DESCRIPTION
<b>KM1S51</b>	5KM1S5102	Kit for 1 section
<b>KM2S51</b>	5KM2S5102	Kit for 2 sections
<b>KM3S51</b>	5KM3S5102	Kit for 3 sections
<b>KM4S51</b>	5KM4S5102	Kit for 4 sections
<b>KM5S51</b>	5KM5S5102	Kit for 5 sections
<b>KM6S51</b>	5KM6S5102	Kit for 6 sections
<b>KM7S51</b>	5KM7S5102	Kit for 7 sections

**Microswitches for 8MS kits**

It's complete with rubber cover and mounting screws: to order separately

**M51 code: 5MIC100**

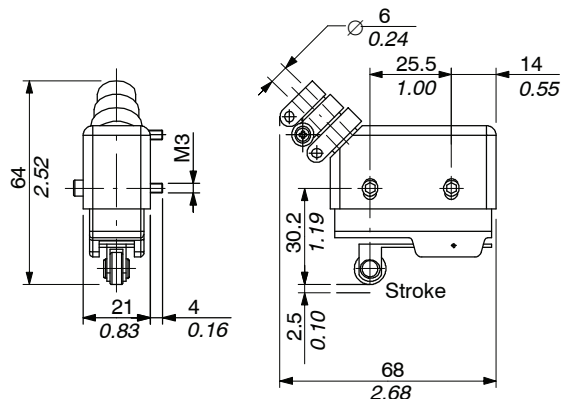

**Operating features**

Max. current / voltage ..... : 15 A / 480 VAC  
 : 0.25 A / 250 VDC  
 Weather protection ..... : IP51

**M67 code: 5MIC200**

Dedicated bracket is needed for the assembly  
code: 3FLA225052

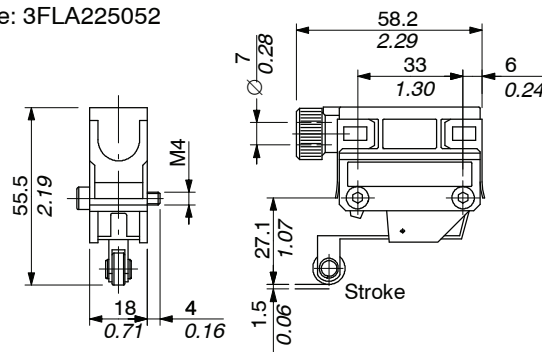

**Operating features**

Max. current / voltage ..... : 5 A / 250 VAC  
 : 0.25 A / 230VDC  
 Weather protection ..... : IP67

**“A” side spool positioners**

**With microswitch type 8MG3(NO)**

With spring return in neutral position and microswitch operated in both directions.

Also available **8MG1(NO)** configuration (microswitch operated in position 1) and **8MG2(NO)** configuration (microswitch operated in position 2); dimensions are the same of 8MG3 configuration.

Same configurations are available with normally closed (NC) contact.

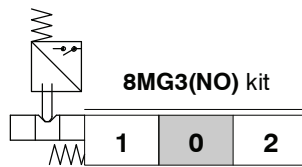
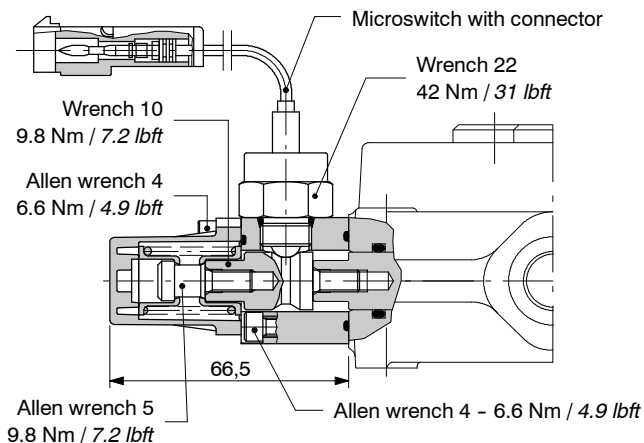

**Other configurations**

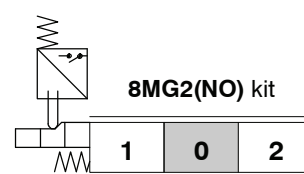
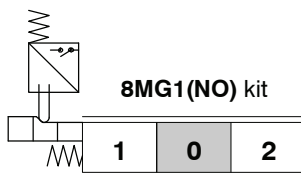

**COMPLETE CONTROLS CODES**

Contact	CONTROL TYPE			Need connector type	
	8MG3	8MG2	8MG1		
NO	5V08105660	5V08105680	5V08105670	C07	see page 129
NC	5V08105662	5V08105682	5V08105672	C17	

**Operating features**

**MICROSWITCH**

- Mechanical life : 5x10<sup>5</sup> operations
- Electrical life (resistive load) : 10<sup>5</sup> oper. - 7A / 13.5VDC
- : 5x10<sup>4</sup> oper. - 10A / 12VDC
- : 5x10<sup>4</sup> oper. - 3A / 28VDC

**More configurations and spare parts**

It's possible to obtain further configurations of complete control, using the MG kit, microswitches and 3 positions “A” side spool positioner, as following draw.

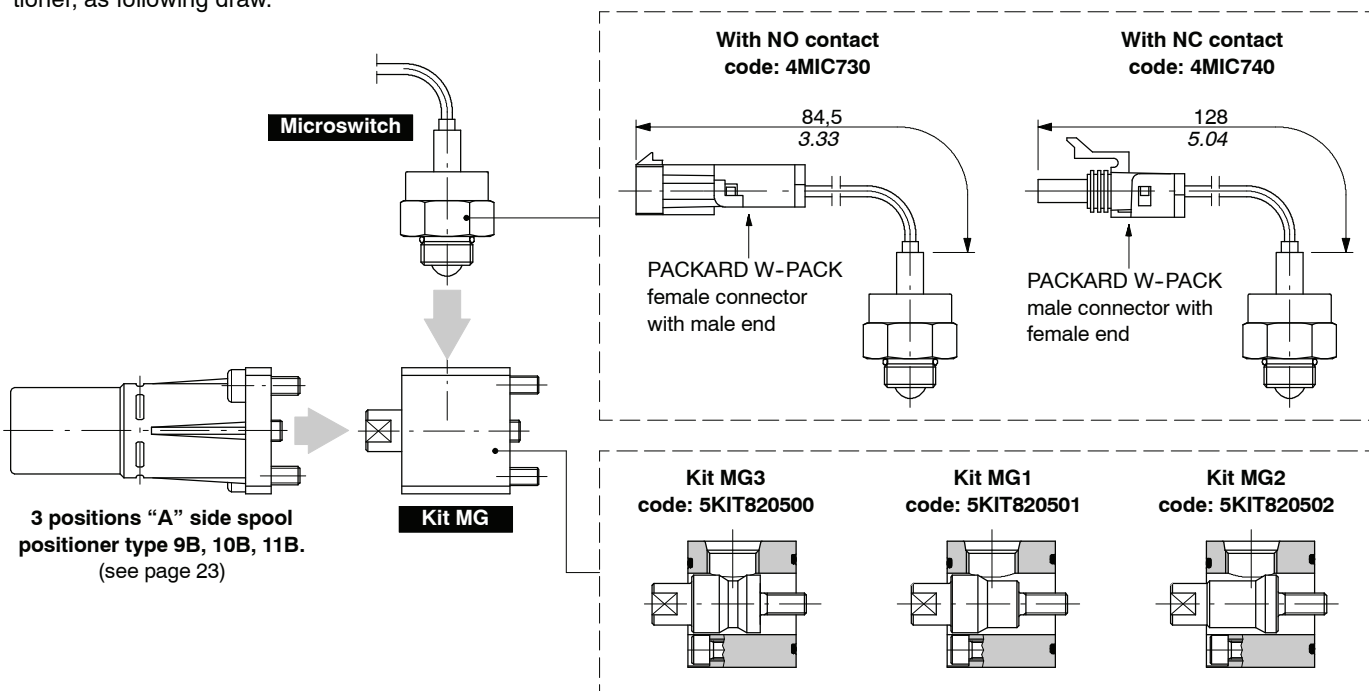

**ON/OFF pneumatic kit type 8P**

With spring return to neutral position.

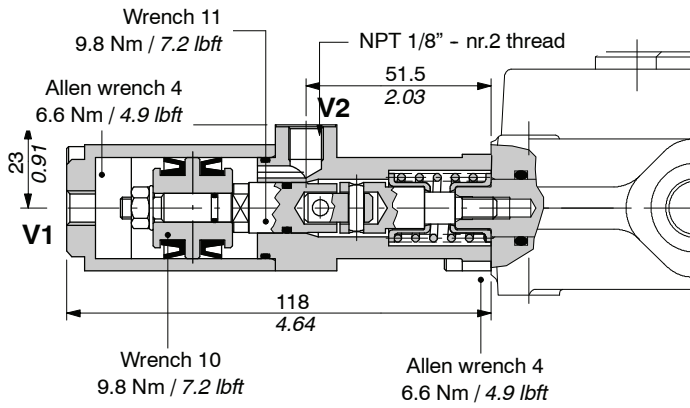
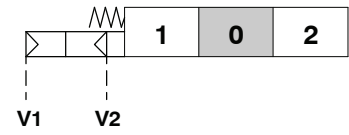

**Operating features**

Pilot pressure ..... : min. 5.5 bar / 80 psi  
 : max. 10 bar / 145 psi

“A” side spool positioners

ON/OFF electropneumatic kit type 8EP3

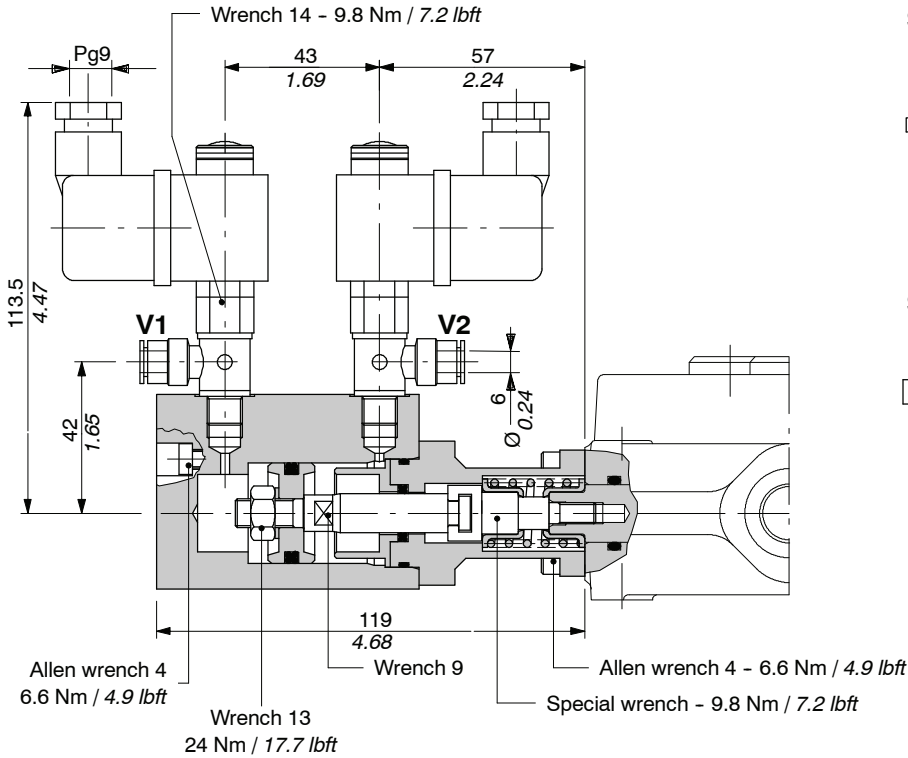

Scheme

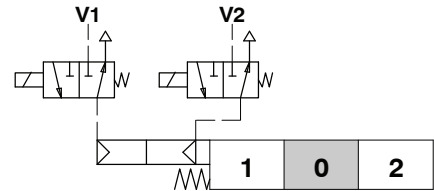

Scheme ISO 1219

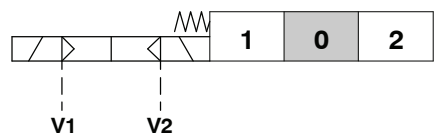

COMPLETE CONTROL CODES

	CONNECTION TYPE	
	ISO6952	Flying leads
Voltage	CONTROL TYPE	
	8EP3	8EP35
12 VDC	5V08105735	5V08105736
24 VDC	5V08105740	5V08105741
Need connector type (see page 129)	C01 (compreso)	/

COIL CODES

Voltage	CONNECTION TYPE	
	ISO6952	Flying leads*
12 VDC	2X4000013	2XB1000120000
24 VDC	2X4000025	2XB1000240000

\* Several type of connectors can be wired on request

Operating features

CONTROL

Pilot pressure ..... : 6 bar / 87 psi  
 (max.10 bar / 145 psi)

COIL

Nominal voltage tolerance .... : ±10%  
 Power rating ..... : 8 W  
 Nominal current ..... : 0.67 A - 12 VDC  
 : 0.33 A - 24VDC  
 Coil insulation ..... : Class F  
 Weather protection ..... : IP65  
 Duty cycle ..... : 100%

Coil with ISO6952 connector

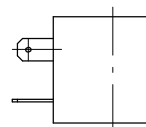

Coil with flying leads

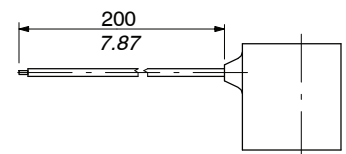



**ON/OFF electrohydraulic kit type 8ED3**

With external pilot and drain.

Allen wrench 4 - 6,6 Nm / 4.9 lbf

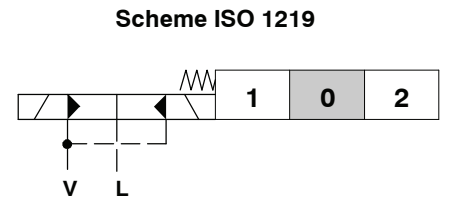
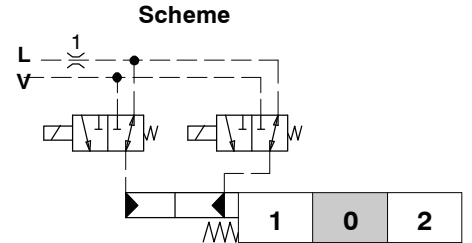
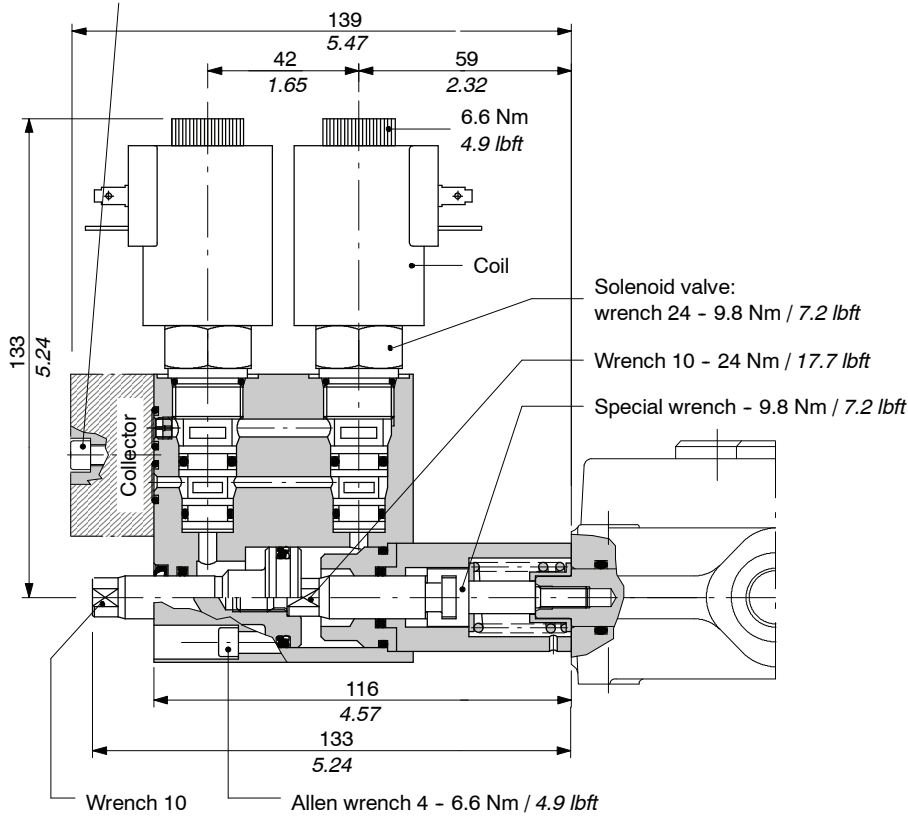

**Operating features**

**CONTROL**

Pilot pressure : min. 10 bar / 145 psi  
 : max. 50 bar / 725 psi  
 Max backpressure on drain L : 25 bar / 360 psi

**COIL**

Nominal voltage tolerance : ±10%  
 Power rating : 21 W  
 Nominal current : 1.75 A - 12 VDC / 0.87 A - 24VDC  
 Coil insulation : Class F  
 Weather protection : IP65  
 Duty cycle : 100%

**COMPLETE CONTROL CODES**

	CONNECTION TYPE			
	ISO4400	AMP JPT		Deutsch DT
		without diode	with diode	
	CONTROL TYPE			
Voltage	8ED3	8ED32	8ED32D	8ED34
12 VDC	5V08105350	5V08105250	5V08105280	5V08105450
24 VDC	5V08105351	5V08105251	5V08105281	5V08105451
Need connector type (see page 129)	C02	C08	C08	C19

“A” side spool positioners

ON/OFF electrohydraulic kit type 8ED3

COIL CODES

Voltage	CONNECTION TYPE			
	ISO4400	AMP JPT		Deutsch DT
		without diodo	with diodo	
12 VDC	2XB1400121100	2XB1400121200	2XB1400121210	2XB1400120400
24 VDC	2XB1400241100	2XB1400241200	2XB1400241210	2XB1400240400

Coil with ISO4400 connection

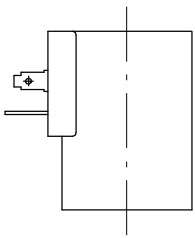

Coil with AMP JPT connection

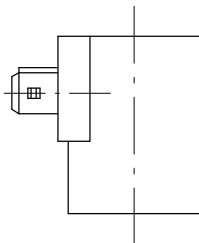

Coil with Deutsch DT connection

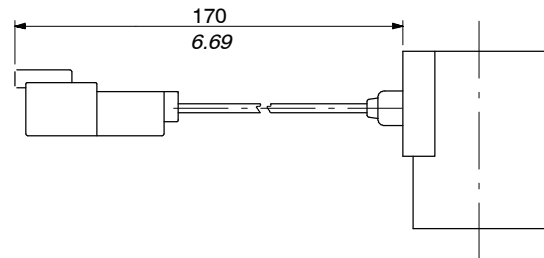

Collector kit for external pilot and drain

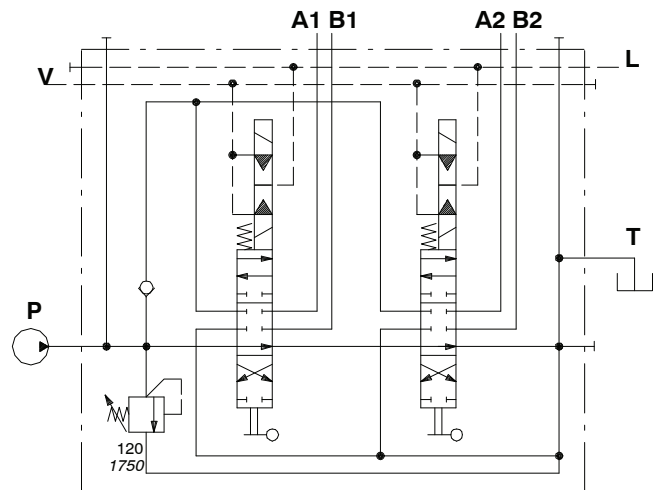
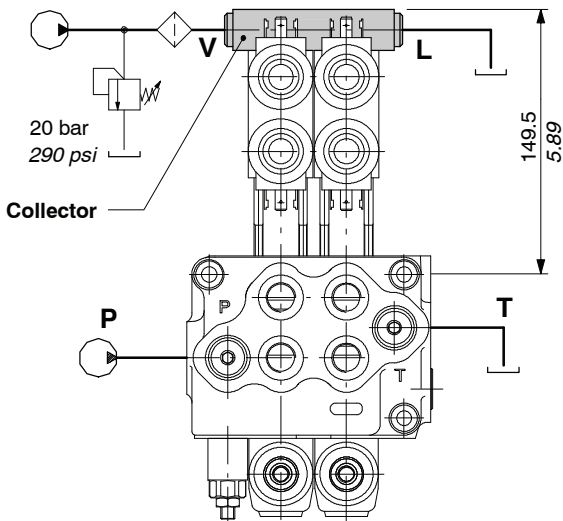

Description example:

SD5/2-P(JG3-120)/18ED3L/18ED3L/AET-KE2S0-24VDC

COLLECTOR KIT CODES

Type	Code *	Description
KE1S0	5KE1S00030	Kit one section
KE2S0	5KE2S00230	Kit for 2 sections
KE3S0	5KE3S00230	Kit for 3 sections
KE4S0	5KE4S00230	Kit for 4 sections
KE5S0	5KE5S00230	Kit for 5 sections
KE6S0	5KE6S00230	Kit for 6 sections

(\*) codes are referred to BSP thread

**ON/OFF electrohydraulic kit type 8ED3**

**Collector kit with pilot and drain lines**

The kit is made of collector, VRP pressure reducing valve and pipes.

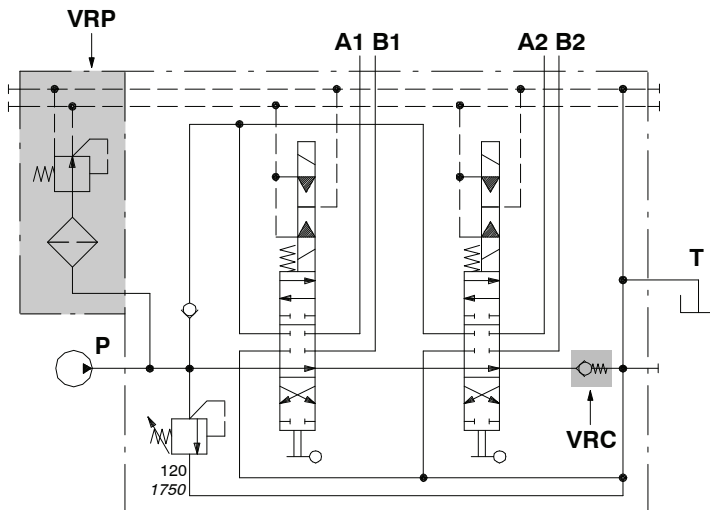
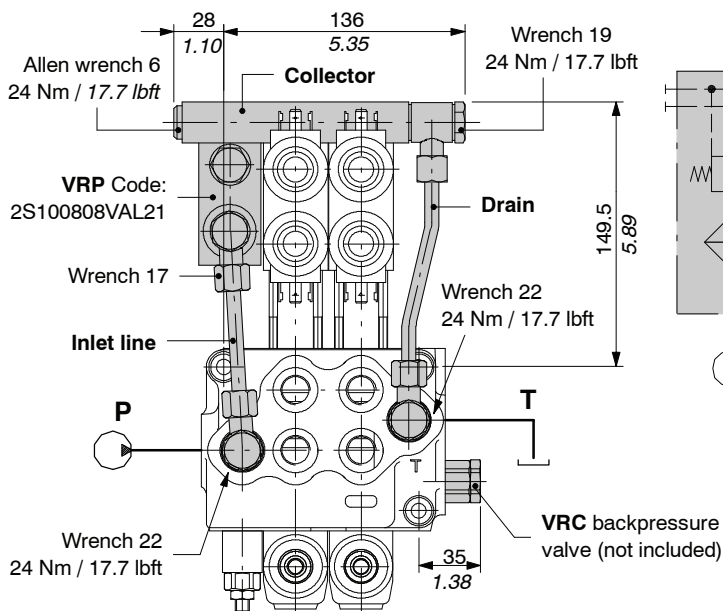

Description example:  
SD5/2-P(JG3-120)/18ED3L/18ED3L/VRC-KE2R3-24VDC

**Operating features**

VRP VALVE

- Output pressure ..... : 20 bar / 290 psi
- Max flow ..... : 8 l/min
- Filtering ..... : 80 μ

**COLLECTOR KIT CODES**

Typo	Code *	Description
KE1R0	5KE1R30230	Kit one section
KE2R0	5KE2R30230	Kit for 2 sections
KE3R0	5KE3R30230	Kit for 3 sections
KE4R0	5KE4R30230	Kit for 4 sections
KE5R0	5KE5R30230	Kit for 5 sections
KE6R0	5KE6R30230	Kit for 6 sections

(\*) Codes are referred to BSP thread

**VRC valve: code X003600010**

Valve assembled on flow through passage provides pilot pressure to the actuator.

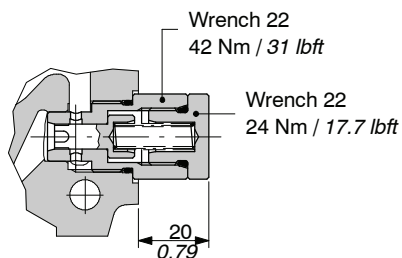

**Pressure drop P→T**

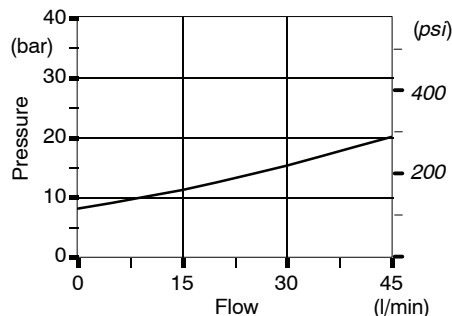

“A” side spool positioners

Particular positioner kits for special spools

13NZ kit

Detent in 4<sup>th</sup> position with spool in: available only for spool type 5DY (see page 16).

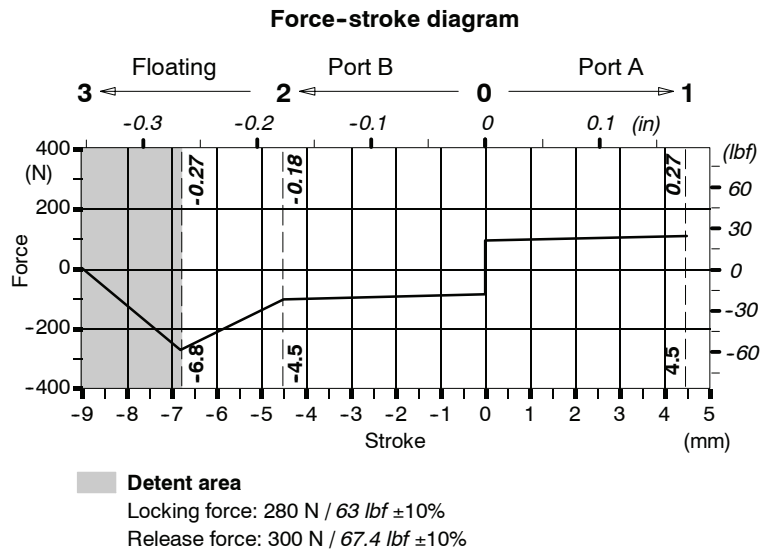
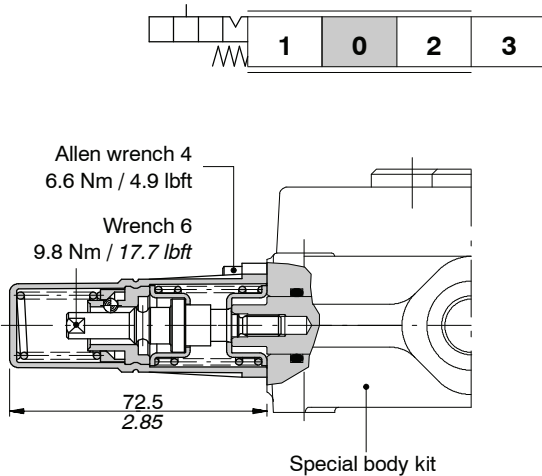

13QN kit

Detent in 4<sup>th</sup> position with spool out: available only for spool type 5PY (see page 17).

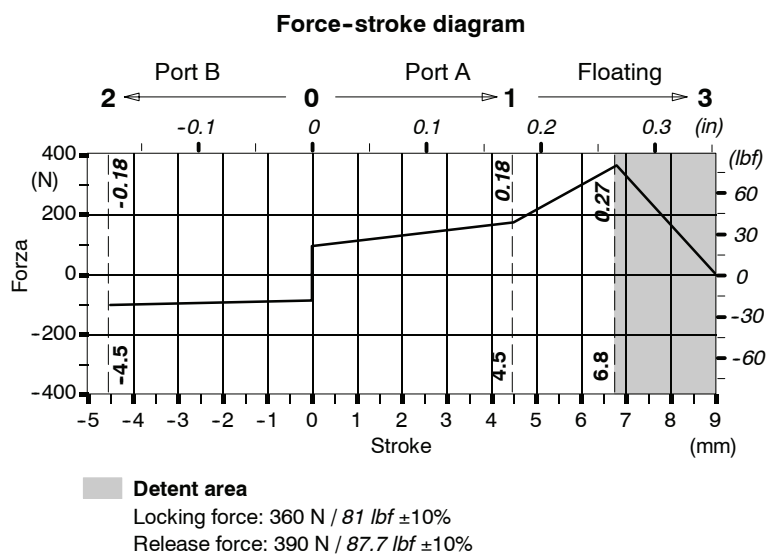
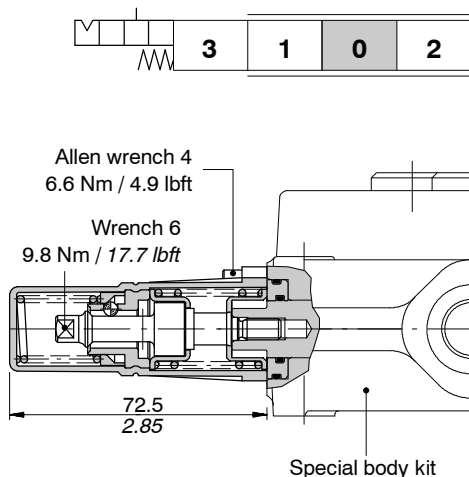

Particular positioner kits for special spools

13FZ kit

4<sup>th</sup> position with spool in and spring return to neutral position.  
Available only for spool type 8 (see page 18).

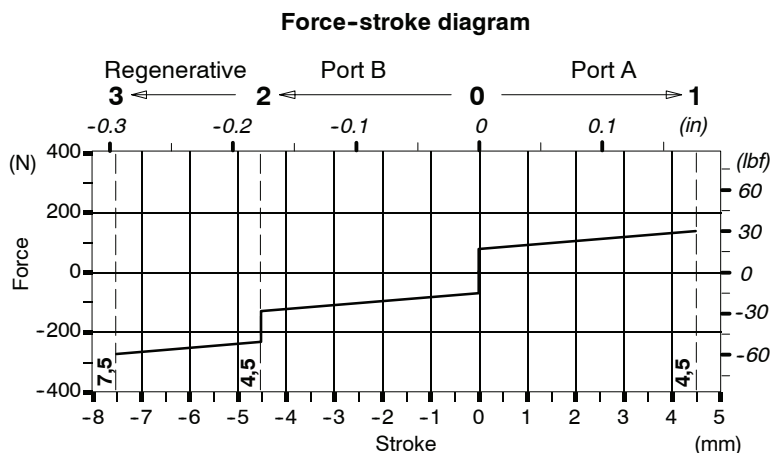
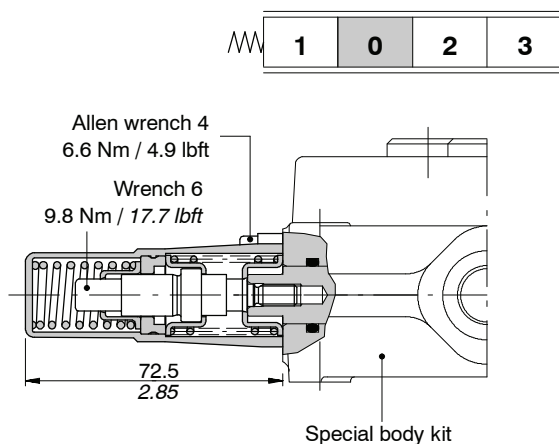

13QNMG3(NO) kit

Detent in 4<sup>th</sup> position with spool out, spring return to neutral position and microswitch operation in both directions.  
The microswitch can be configured with **NO** (normally open) or **NC** (normally closed) contact  
Available only for spool type 5PY (see page 17).

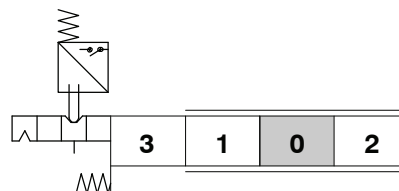
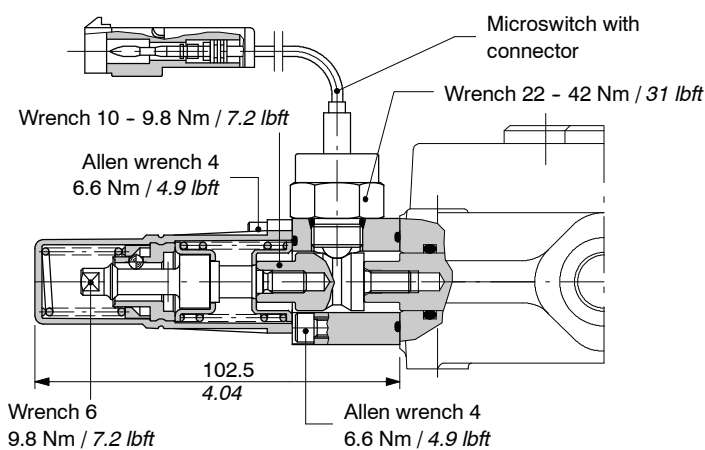

Operating features

MICROSWITCH

- Mechanical life : 5x10<sup>5</sup> operations
- Electric life (resistive load) : 10<sup>5</sup> operations - 7A / 13.5VDC
- : 5x10<sup>4</sup> operations - 10A / 12VDC
- : 5x10<sup>4</sup> operations - 3A / 28VDC

COMPLETE CONTROL CODES

	Contact type	Needs connector type	
5V13405660	NO	C07	see page
5V13405661	NC	C17	129

CODICI MICROINTERRUTTORI DI RICAMBIO

Microswitch kit with NO contact  
code: 4MIC730

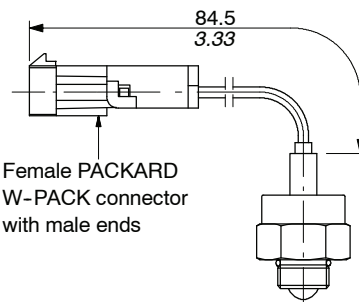

Microswitch kit with NC contact  
code: 4MIC740

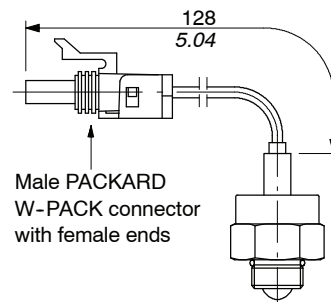

**"A" side spool positioners**

**Particular positioner kits for special spools**

**With electromechanical lock**

The positioners for special spools (13NZ, 13QN, 13FZ), are also available with spool electromechanical lock in neutral position; if coil is excited the spool can be operated.

For kit K and coils features and dimensions, see page 24: for informations contact Sales Department.

**Coil**

**Kit K**  
Complete actuator kit:  
code 5KIT810500

**CODICI BOBINE**

Voltage	CONNECTION TYPE		
	ISO4400	Deutsch DT	Packard M-Pack
12 VDC	2X4300012	2X4300014	YSOL300013
24 VDC	2X4300024	2X4300026	YSOL300025
<b>Need connector type</b> (see page 129)	C02	C19	C20

**13NZ positioner kit**  
(see page 36)  
for spool type 5DY

**13QN positioner kit**  
(see page 36)  
for spool type 5PY

**13FZ positioner kit**  
(see page 37)  
for spool type 8

**Special body kit** depending on used spool: for information contact Sales Department.

Lever control

Type L

Alluminium with protection boot lever pivot box; it can be rotated 180° (execution L180).

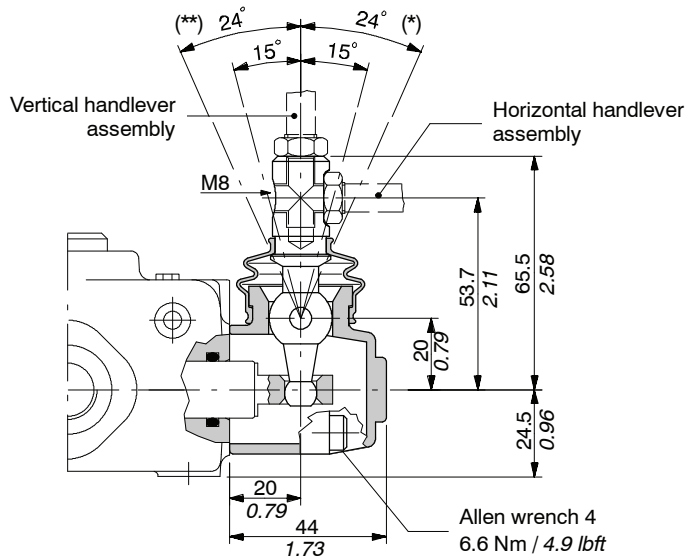

NOTE (\*) - With spool type 5DY (see page 16)  
(\*\*) - With spool type 5PY (see page 17)

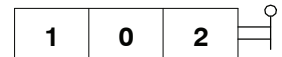

Execution L180

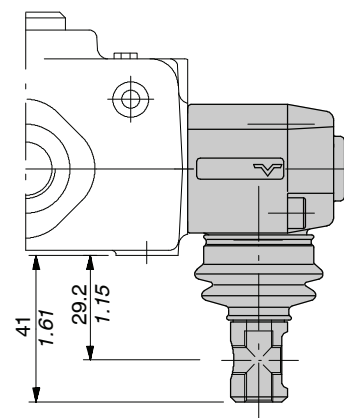

Type LM10

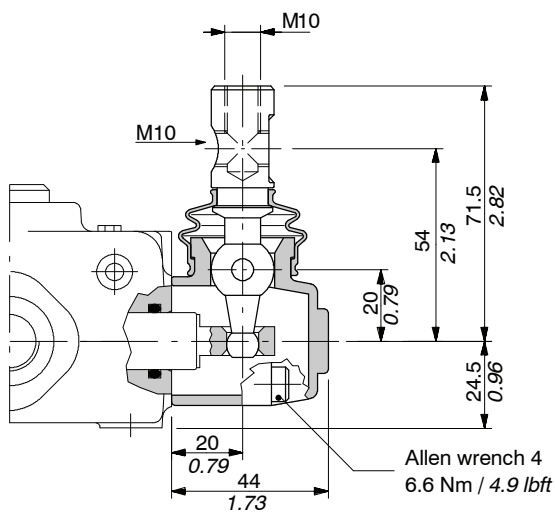
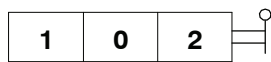

Type LF1

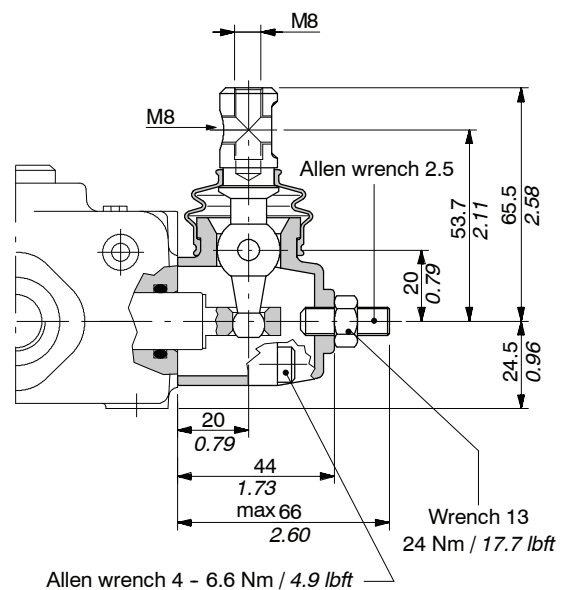
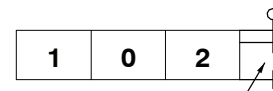

**"B" side options****Special lever controls**

Safety levers with lock in neutral complete with handlelever; lift handlelever knob to operate.

**Type LEB**

To be used with body valves without auxiliary relief valves flanged on the working ports.

Available with execution **LEBS**, code **5LEV605100**, for configurations with auxiliary valves type BP and BPS: it operates floating spool (4 positions) only by pulling the lever, with spool in (type **5DY**).

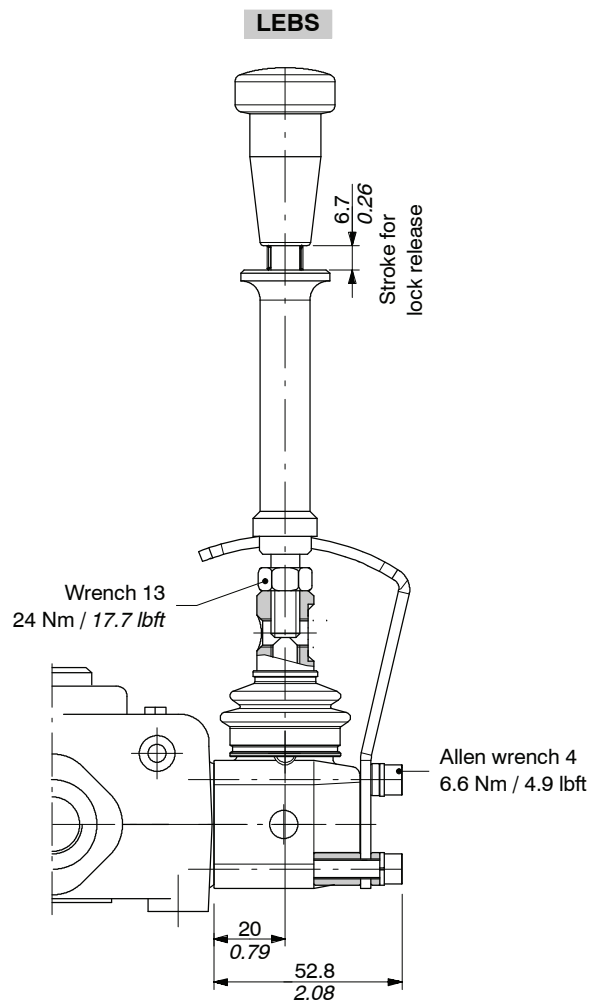
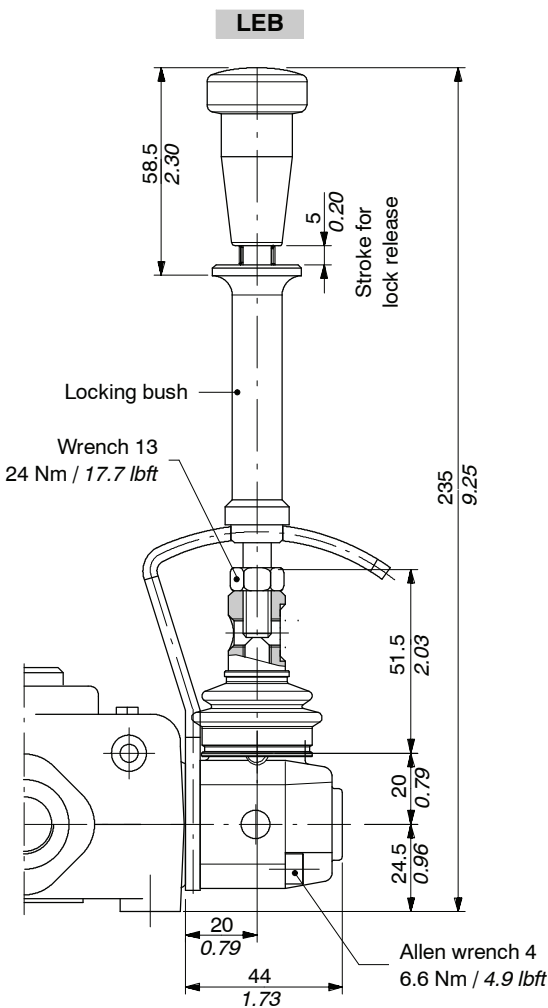
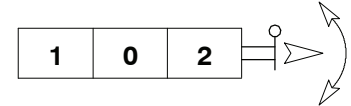



Special lever controls

Type LUP

Available as LUP(R150) configuration, with length L = 150 mm / 5.91 in and red knob: code 5LEV805010.

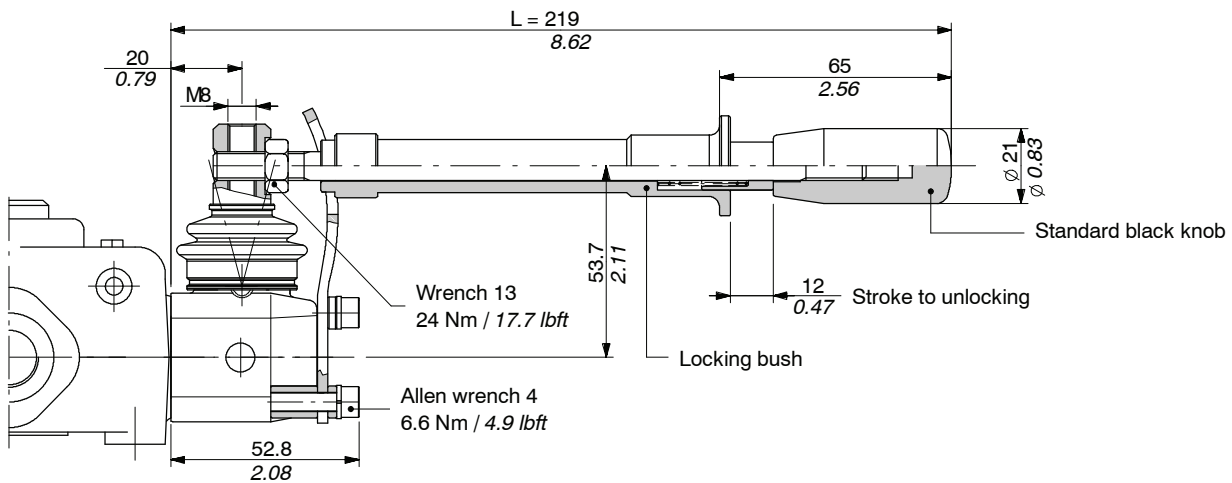

Controls arrangement

Type SL

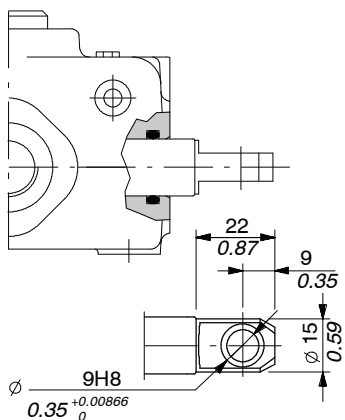
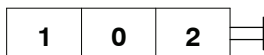

Type SLP

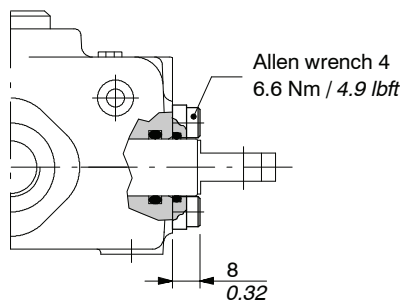
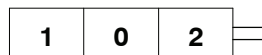

Mechanical control with dust-proof plate.

Type SLC

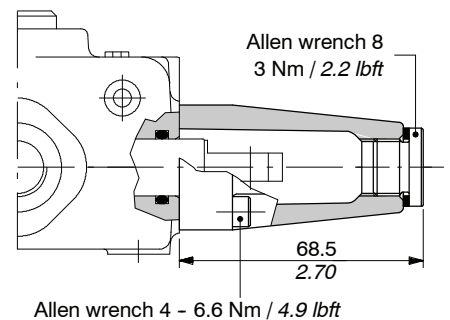
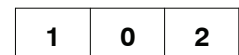

Protection cap usable with pneumatic, electro-pneumatic, and electro-hydraulic spool positioners.

**“B” side options**

**TQ cable remote control kit**

Waterproof cap prearranged for remote control with flexible cable.

1	0	2
---	---	---

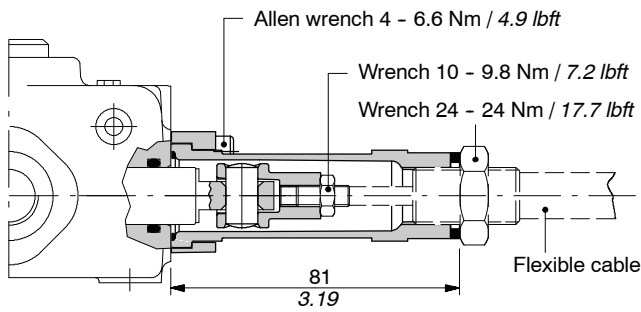

NOTE - For more information about remote cable control, require appropriate documentation.

**Connection example**

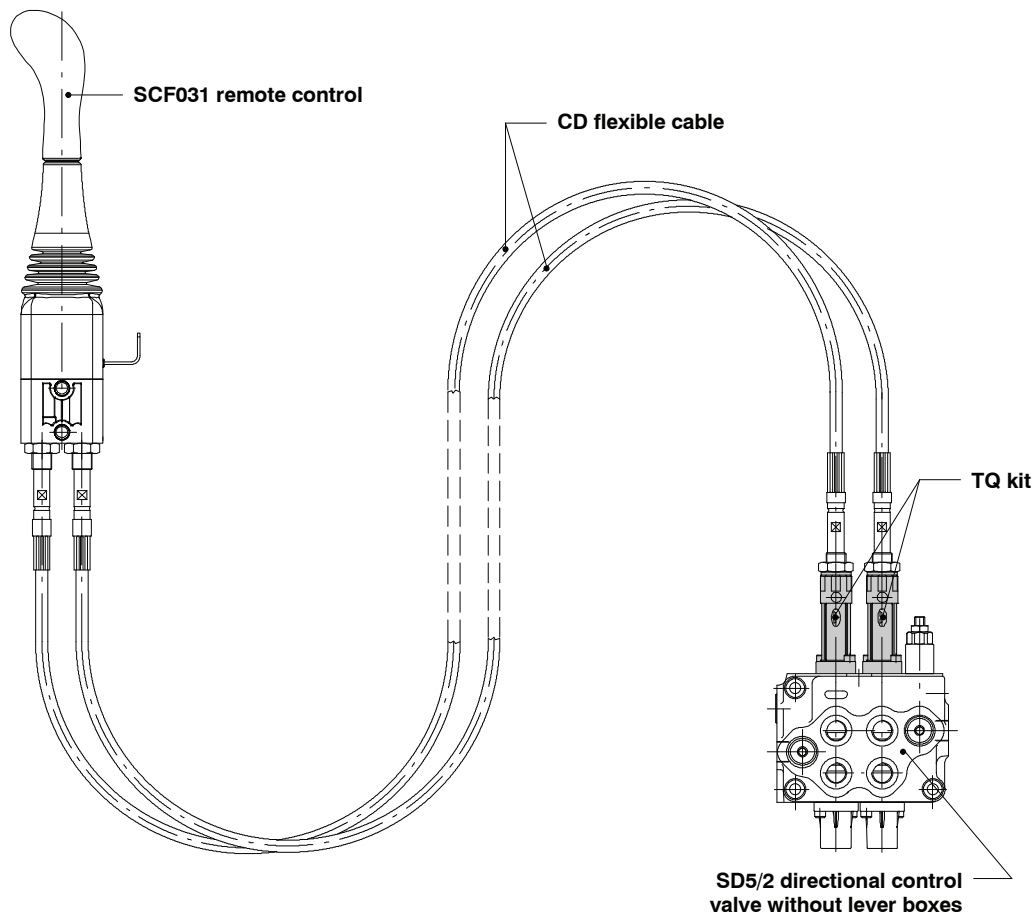

NOTE - For best efficiency, “A” side positioner with spring return type C is suggested (see page 20)

LCB mechanical joystick for two sections control

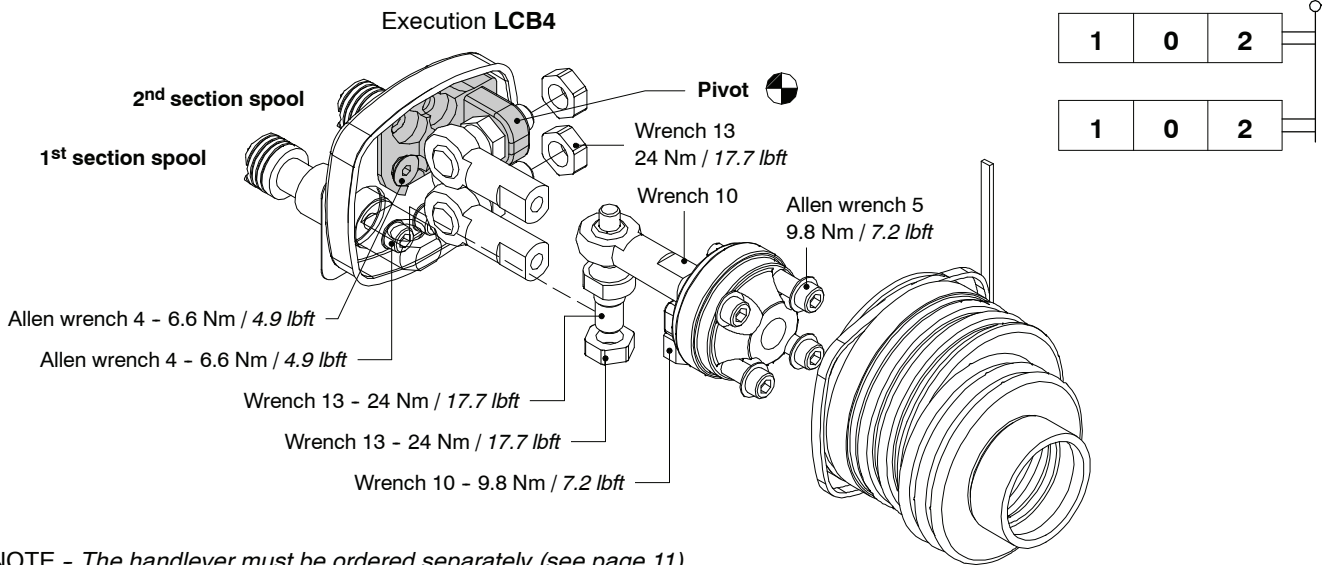

NOTE - The handlever must be ordered separately (see page 11).

Dimensions and movement scheme

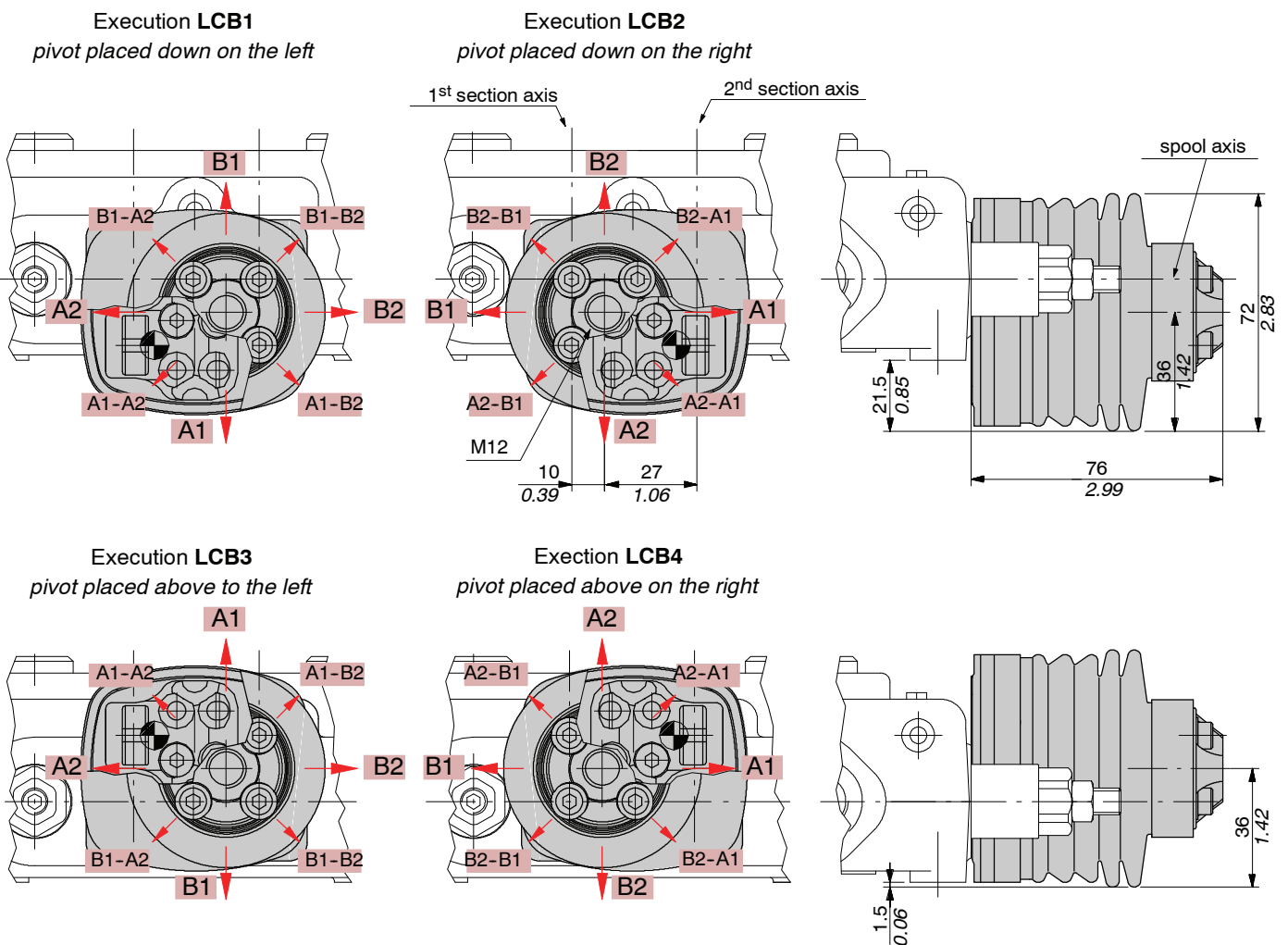

NOTE - Don't use with spool type 5DY.

## Complete controls

### 8ESN solenoid control

Direct control by double solenoid with spring return to neutral position, available with emergency manual override.

It's necessary special spool and standard body (body kit without spool seals).

Due to the large dimension, it's not possible to assembly more than one control consecutively, except **SD5/2-P** and **SD5/3-P** that have special bodies with bigger centre-to-centre.

### Description example:

**SD5 / 1 - P (JG3-120) / 1 8ESN LES / AET - 24VDC**

1.

2.

3.

4.

5.

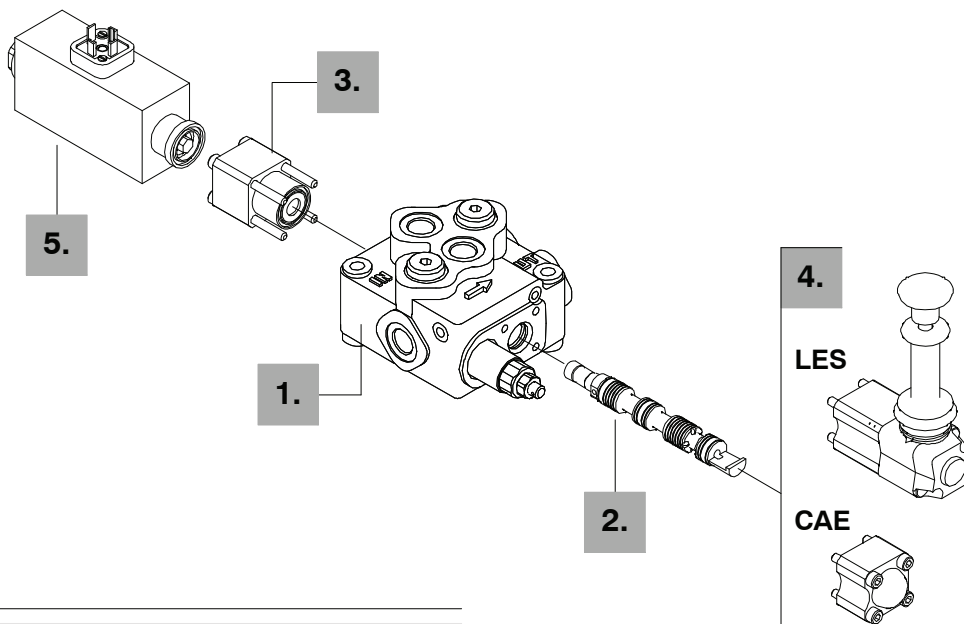

#### 1. Body kit \*

TYPE	CODE	DESCRIPTION
<b>SD5/1-P</b>	5KC1193100	1 section, standard body
<b>SD5/2-PS</b>	5KC1223003	2 sections, special body
<b>SD5/3-PS</b>	5KC1243006	3 sections, special body

#### 2. Spools options

TYPE	CODE	DESCRIPTION
<b>1(ESN)</b>	3CU1210036	Double acting, 3 positions, with A and B closed in neutral position
<b>2(ESN)</b>	3CU1225036	Double acting, 3 positions, with A and B open to tank in neutral position

#### 3. Connection kit

TYPE	CODE	DESCRIPTION
<b>8ESN</b>	5V08009	For solenoid joint, with spring return in neutral position

#### 4. "B" side options

TYPE	CODE	DESCRIPTION
<b>LES</b>	5LEV105410	Safety lever pivot box for manual operation
<b>CAE</b>	5COP205100	Endcap

#### 5. Solenoid

TYPE	CODE	DESCRIPTION
<b>10.5VDC</b>	XSOL314310	Nominal voltage 10.5VDC
<b>12VDC</b>	XSOL314312	Nominal voltage 12VDC
<b>24VDC</b>	XSOL314324	Nominal voltage 24VDC
<b>192VDC</b>	XSOL314192	Nominal voltage 192VDC; (for 220 VAC supply)

NOTE (\*) - Codes are referred to **BSP** threads.

8ESN solenoid control

Electric wiring example

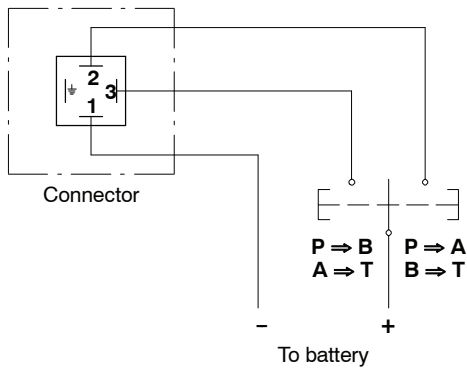

8ESNLES kit  
with safety lever pivot box

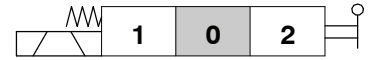

8ESNCAE kit  
with encadp

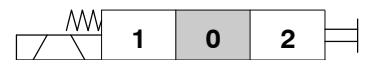

Operating features

CONTROL

Internal leakage A(B)→T

( $\Delta p = 100 \text{ bar} - 1450 \text{ psi} / T = 40^\circ\text{C}$ ) : max.  $10 \text{ cm}^3/\text{min} - 0.61 \text{ in}^3/\text{min}$

COIL

Nominal voltage tolerance :  $\pm 10\%$

Power rating : 65 W

Coil insulation : class H

Duty cycle : 100%

Connection ISO4400

(needs C03 connector for VDC supply or C05 connector for VAC supply; see page 129)

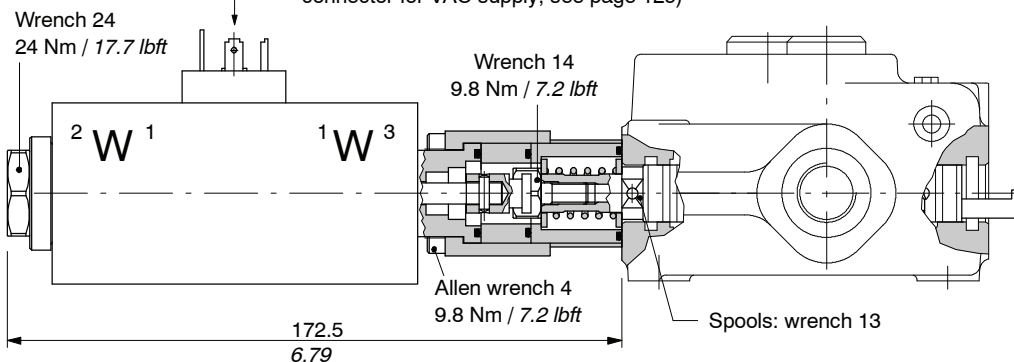

Manual operation:  
lift the bush to lever  
unlocking

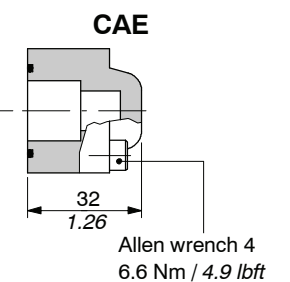
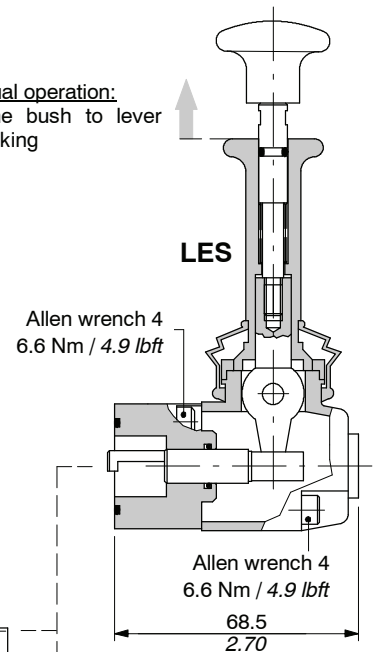

## Complete controls

### 8ES solenoid control

Solenoid direct control with spring return to neutral position.

It needs special spools and standard body (body kit without seals on spool).

### Description example:

SD5 / 1 - P (JG3-120) / 1 8ES3 4 / AET - 24VDC

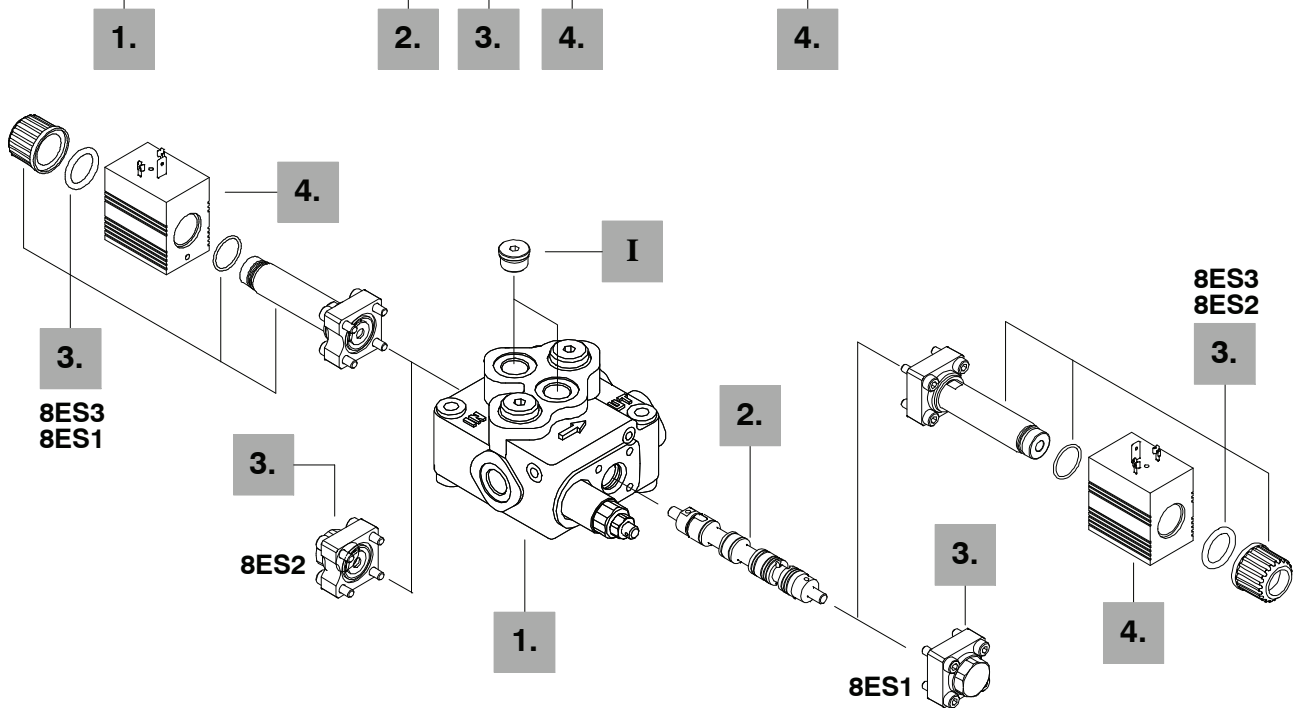

#### 1. Body kit \*

TYPE	CODE	DESCRIPTION
SD5/1-P	5KC1193100	1 section
SD5/2-P	5KC1223100	2 sections
SD5/3-P	5KC1243100	3 sections
SD5/4-P	5KC1273100	4 sections
SD5/5-P	5KC1313100	5 sections
SD5/6-P	5KC1353100	6 sections
SD5/7-P	5KC3E3100	7 sections

#### 2. Spool options

TYPE	CODE	DESCRIPTION
1(ES)	3CU1210011	Double acting, 3 positions, with A and B closed in neutral position
2(ES)	3CU1225010	Double acting, 3 positions, with A and B open to tank in neutral position

NOTE (\*) - Codes are referred to **BSP** threads.

#### 3. Control kit

TYPE	CODE	DESCRIPTION
8ES1	5CAN08024	Single acting P→A, with spring return to neutral position
8ES2	5CAN08024	Single acting P→B, with spring return to neutral position
8ES3	5CAN08025	Double acting, with spring return to neutral position

#### 4. Coils

TYPE	CODE	DESCRIPTION
<u>With ISO4400 connector</u>		
10.5VDC	4SOL412012	Nominal voltage 10.5VDC
12VDC	4SOL412012	Nominal voltage 12VDC
24VDC	4SOL412024	Nominal voltage 24VDC
<u>With Deutsch DT connector</u>		
4-10.5VDC	4SOL412111	Nominal voltage 10.5VDC
4-12VDC	4SOL412112	Nominal voltage 12VDC
4-24VDC	4SOL412124	Nominal voltage 24VDC

#### I "A" and "B" ports plugs \*

TYPE	CODE	DESCRIPTION
G3/8	3XTAP722160	For single acting controls type 8ES1 and 8ES2

8ES solenoid control

Electric wiring example

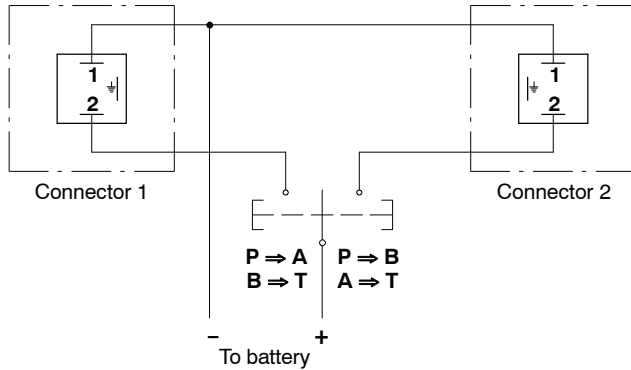

8ES3 kit double acting

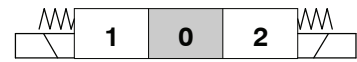

8ES3 kit double acting

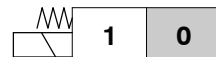

8ES3 kit double acting



Operating features

CONTROL

Internal leakage A(B)→T

( $\Delta p = 100 \text{ bar} - 1450 \text{ psi} / T = 40^\circ\text{C}$ ) : max.  $15 \text{ cm}^3/\text{min} - 0.91 \text{ in}^3/\text{min}$

COIL

Nominal voltage tolerance :  $\pm 10\%$

Power rating : 36 W

Max. operating current : 3.43 A - 10.5 VDC

: 3 A - 12 VDC

: 1.5 A - 24VDC

Weather protection : IP65 - ISO4400 / P67 - Deutsch DT

Coil insulation : class H

Insertion : 100%

Operating condition diagram

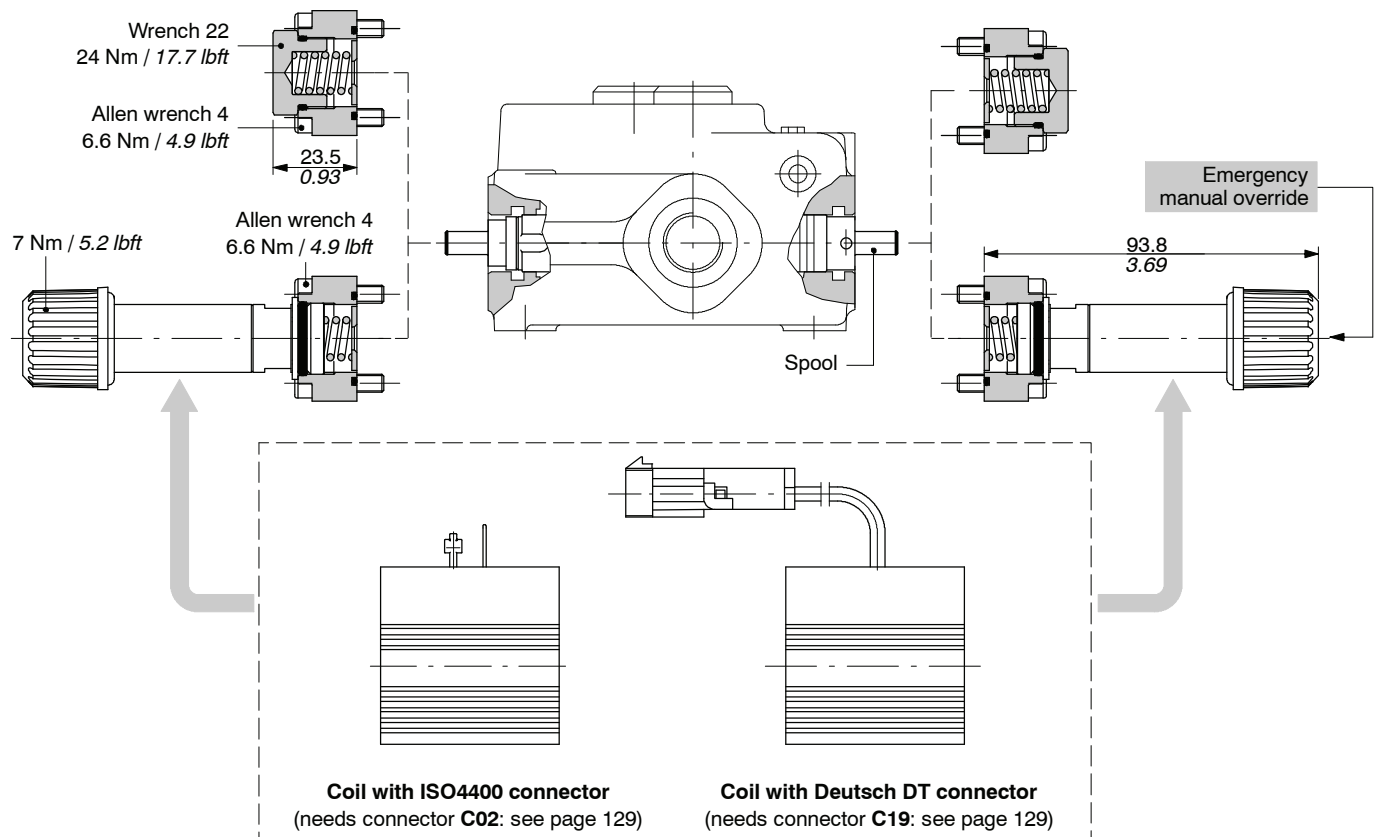
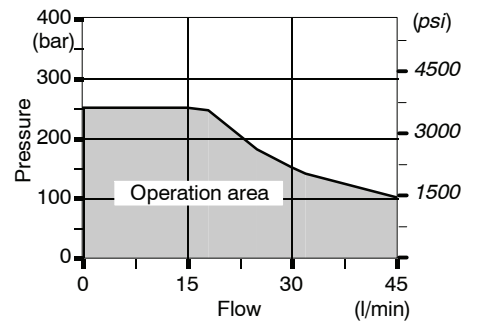

Complete controls

Proportional hydraulic control type 8IM code 5IDR205021

It can be used with standard spools and body (body kit without seals on spool).

Coupling suggested with type 1CS spool (see page 13).

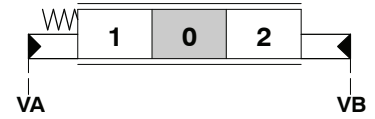
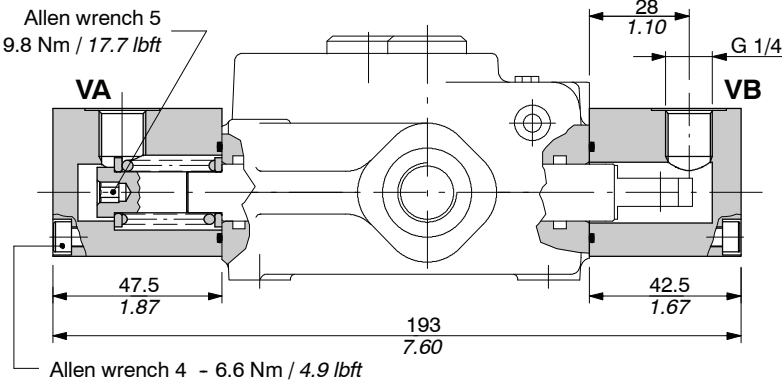

Operating features

Pilot pressure : max. 50 bar / 730 psi

Internal leakage A(B)→T ( $\Delta p = 100 \text{ bar} - 1450 \text{ psi} / T = 40^\circ\text{C}$ )

: max. 6 cm<sup>3</sup>/min - 0.37 in<sup>3</sup>/min

Pilot pressure - stroke diagram

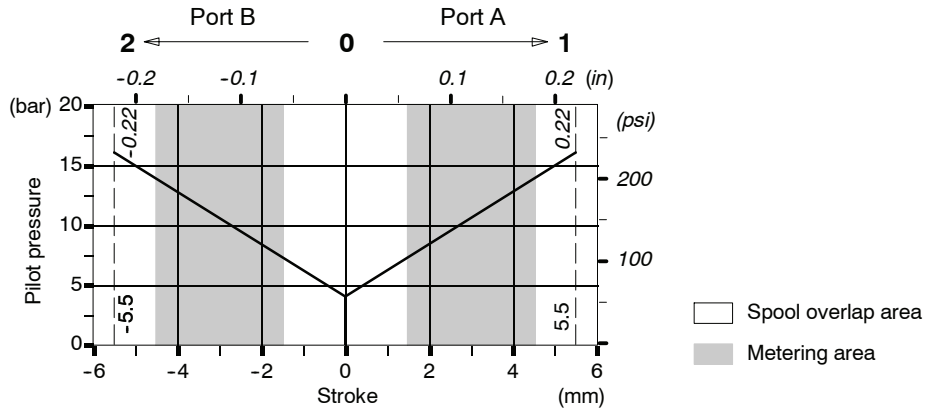

Connection example

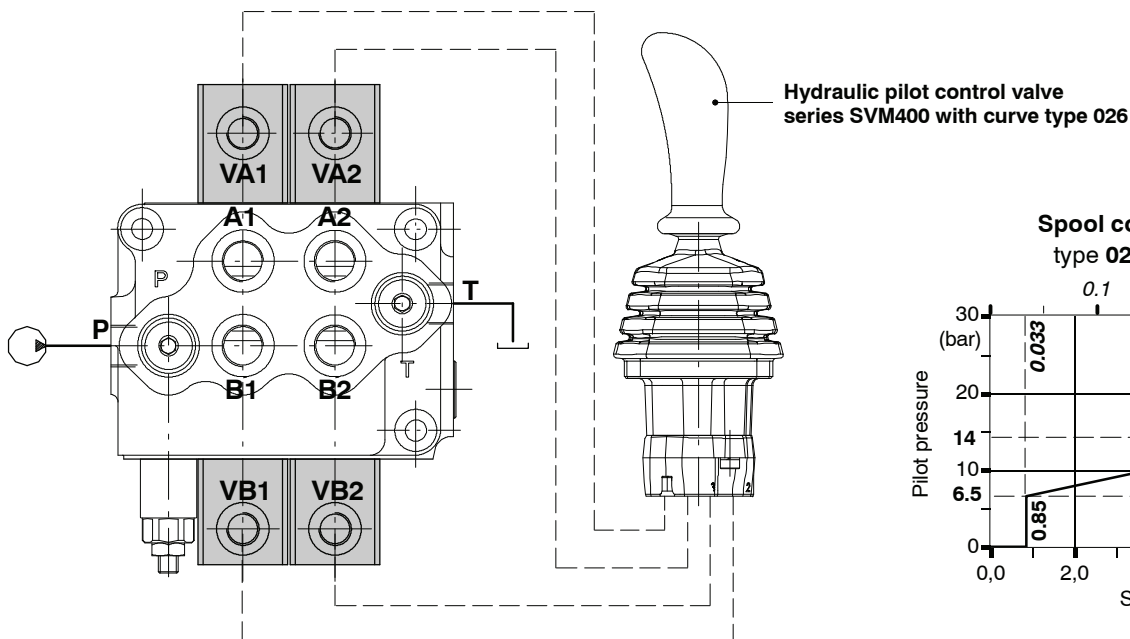

Spool control curve type 026 with step

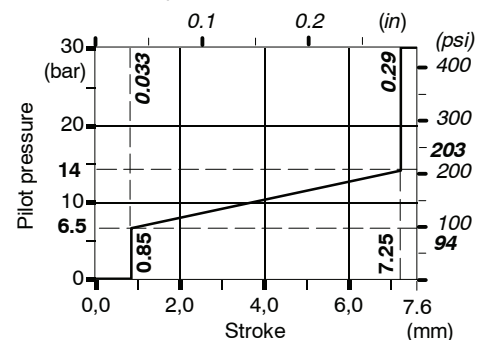



It's possible to have open centre, closed centre and carry-over.

Unloader valves are available: these valves need special bodies with appropriate cavity on lateral outlet port, the tank connection T must be on top.

**AET: open centre (standard)**

See page 9.

**AE: with carry-over**

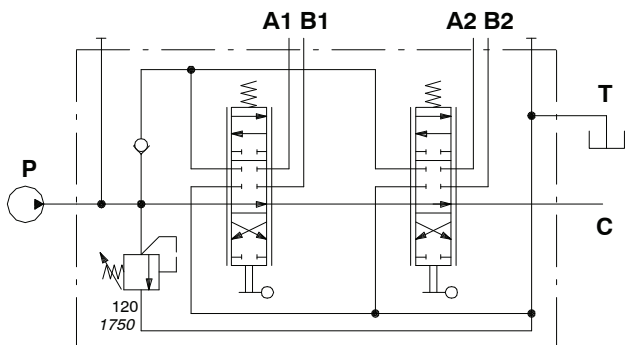
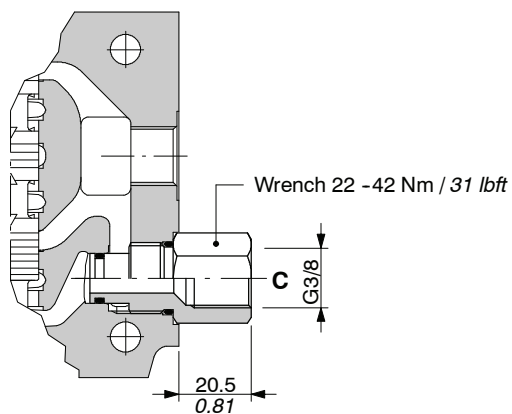

Description example: SD5/2-P(KG3-120)/18L/18L/AE

**AEK: closed centre**

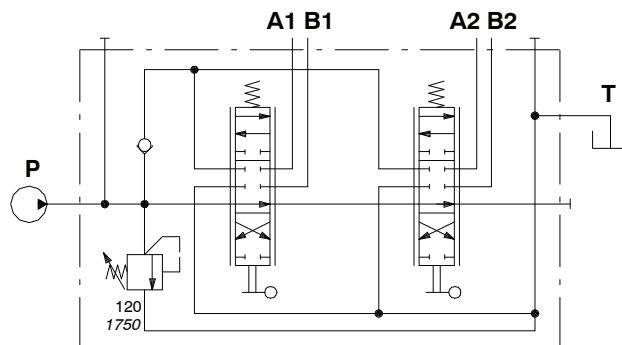
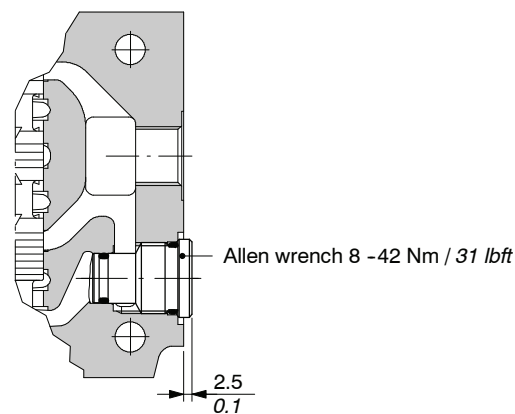

Description example: SD5/2-P(KG3-120)/18L/18L/AEK

**With hydraulic pilot unloader valve type L**

For safety reasons it's provided with pilot port plugged.

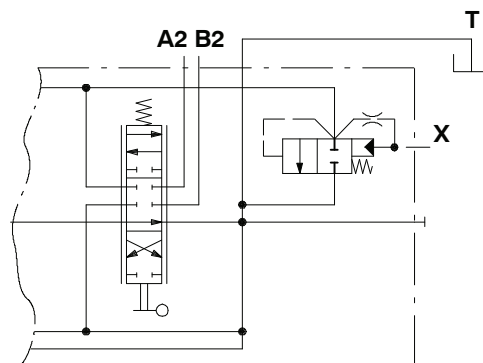
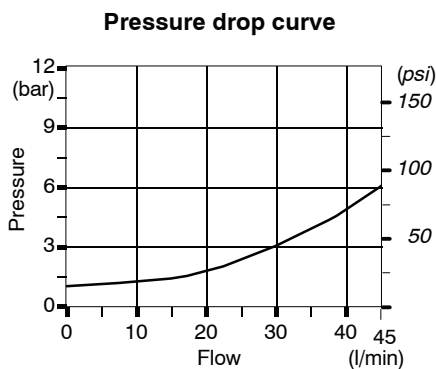
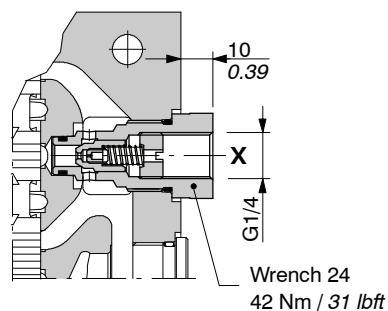

Description example: SD5/2-P(JG3-120)/18L/18L/AET-L

**Operating features**

Internal leakage ..... : 10 cm<sup>3</sup>/min a 100 bar  
 : 0.61 in<sup>3</sup>/min at 1450 psi

## Outlet port options

### With solenoid pilot unloader valve

For the complete valve must be ordered the cartridge and the coil both; to follow please see code list and description composition.

Example of directional valve with normally open unloader valve

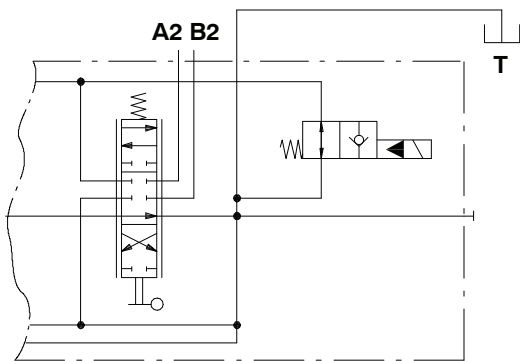

Description example:

SD5/2-P(JG3-120)/18L/18L/AET-ELNW-12VDC

Example of directional valve with normally closed unloader valve

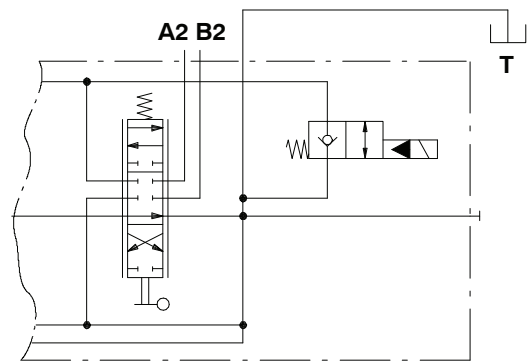

Description example:

SD5/2-P(JG3-120)/18L/18L/AET-ELNW(NC)-12VDC

### Description example:

SD5 / 2 - P (JG3-120) / 18L / 18L / AET-ELNW 4 (NC) - 12VDC

1.

2.

1.

2.

#### 1. Solenoid pilot unloader valve

TYPE	CODE	DESCRIPTION
AET-ELNW	0EFW0132002	Normally open, without emergency
AET-ELNW(NC)	0EFW0132003	As previous, normally closed
AET-ELTW	0EFW0132000	Normally open, with "push&twist" emergency type
AET-ELPW	0EFW0132001	Normally open, with push-button emergency type

#### 2. Coil

TYPE	CODE	DESCRIPTION
<u>With ISO4400 connection</u>		
12VDC	4SLE001200	Nominal voltage 12VDC
DB-12VDC	4SLE001217	As previous, with bi-directional diode
24VDC	4SLE002400	Nominal voltage 24VDC
DB-24VDC	4SLE002408	As previous, with bi-directional diode
<u>With AMP JPT connection</u>		
2-12VDC	4SLE001203	Nominal voltage 12VDC
2DB-12VDC	4SLE001211	As previous, with bi-directional diode
2-24VDC	4SLE002403	Nominal voltage 24VDC
<u>With Deutsch DT connection</u>		
4-12VDC	4SLE001202	Nominal voltage 12VDC, parallel connection
4DB-12VDC	4SLE001216	As previous, with bi-directional diode
4PD-12VDC	4SLE001201	Nominal voltage 12VDC, perpendicular connection
4PDDB-12VDC	4SLE001209	As previous, with bi-directional diode
4-24VDC	4SLE002402	Nominal voltage 24VDC, parallel connection
4PD-24VDC	4SLE002401	Nominal voltage 24VDC, perpendicular connection
4PDDB-24VDC	4SLE002407	As previous, with bi-directional diode

With solenoid pilot unloader valve

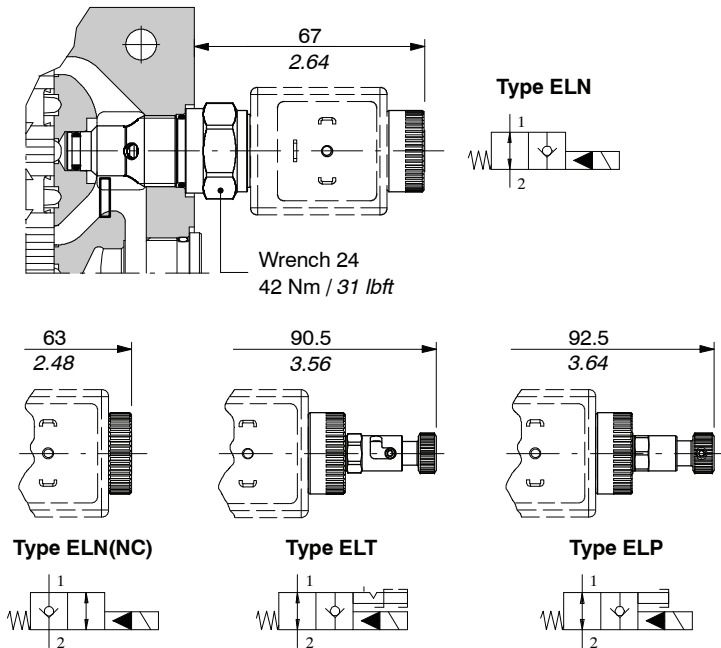

Valve operating features

- Max. flow ..... : 45 l/min
- Max. pressure ..... : 315 bar / 4600 psi
- Internal leakage (from 1 to 2) : max. 3 cm<sup>3</sup>/min at 100 bar  
: max . 4.6 in<sup>3</sup>/min at 1450 psi

Valve pressure drop from 1 to 2 in open position

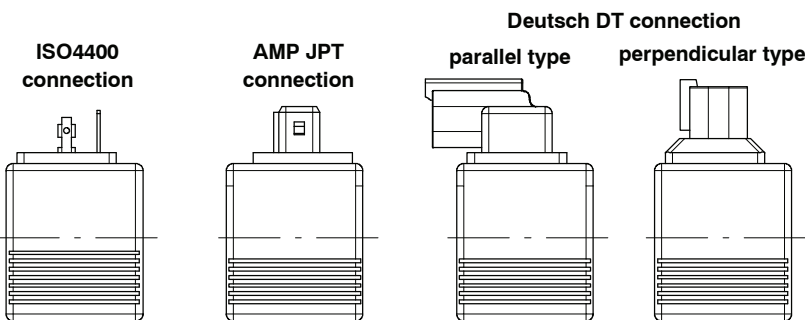
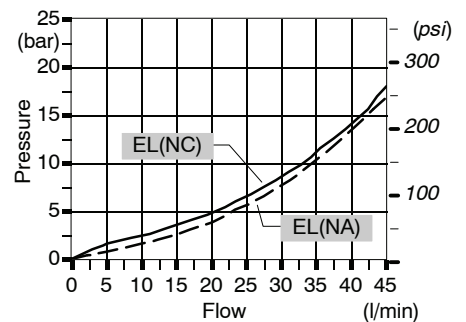

Coil operating features

- Nominal voltage tolerance. : ±10%
- Power rating ..... : 19.3 W - 12 VDC  
: 19.2 W - 24 VDC
- Max. operating current ... : 1.61 A - 12 VDC  
: 0.80 A - 24VDC
- Coil insulation ..... : Class H
- Weather protection ..... : IP65 - ISO4400  
: IP69K - Deutsch DT  
: IP65 - AMP JPT
- Insertion ..... : 100%

LT: unloader valve prearrangement

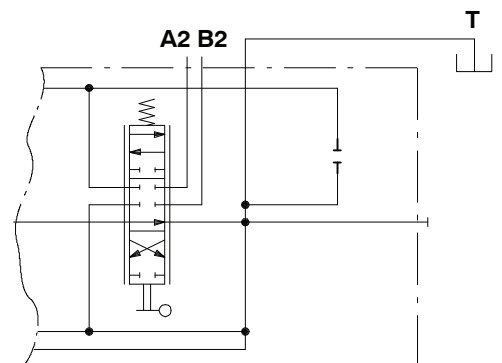
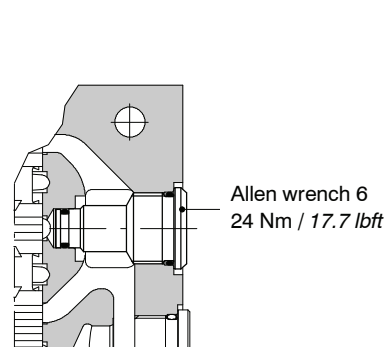

Description example:  
SD5/2-P(JG3-120)/18L/18L/AET-LT

**Service and auxiliary valves**

All service and auxiliary valves need **special body**: contact Sales Department.

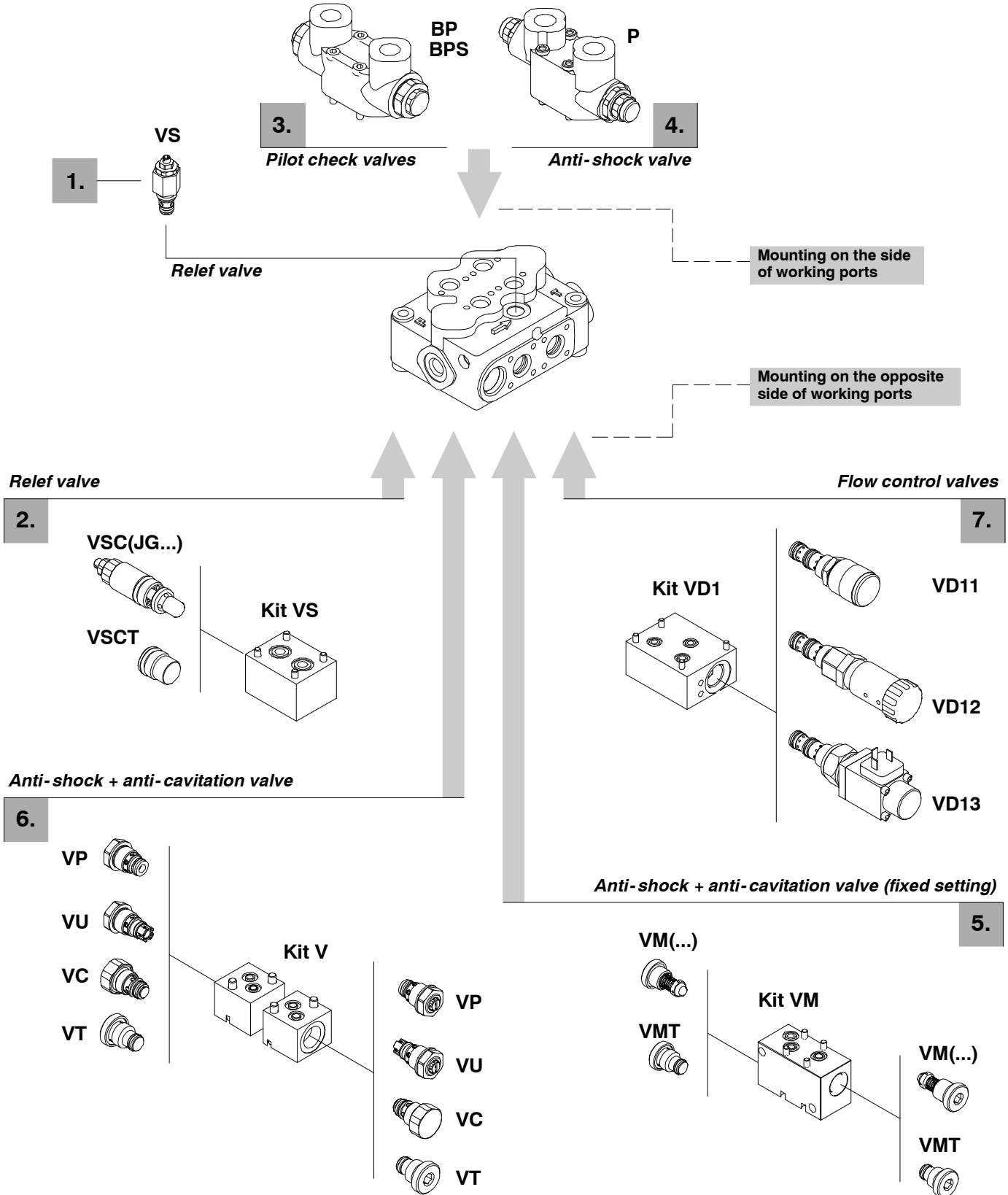

**1. Relief valves** *page 54*

TYPE	CODE	DESCRIPTION
<b>VS(G3-100)</b>	3XCAR505113	Range 40 to 200 bar / 580 to 2900 psi standard setting 100 bar / 1450 psi
<b>VST</b>	3XTAP419300	Valve blanking plug

**2. Flange mounted relief valve** *page 55*

TYPE	CODE	DESCRIPTION
<b>VSC(JG2-60)</b>	5KIT105412	Range 40 to 80 bar / 580 to 1150 psi standard setting 60 bar / 870 psi
<b>VSC(JG3-100)</b>	5KIT105413	Range 63 to 200 bar / 900 to 2900 psi standard setting 100 bar / 1450 psi
<b>VSC(JG4-200)</b>	5KIT105414	Range 160 to 250 bar / 2300 to 3600 psi standard setting 200 bar / 2900 psi
<b>VSCT</b>	XTAP623282	Valve blanking plug
<b>Kit VS</b>	5CO2420000	Mounting block kit

**3. Pilot check valves** *page 56*

Supplied with mounting block

TYPE	CODE	DESCRIPTION
<u>Directv type</u>		
<b>BP1</b>	602002000*	Block with valve on port A
<b>BP2</b>	602002000*	Block with valve on port B
<b>BP3</b>	602002100*	Block with valves on ports A and B
<b>BP</b>	XCAR605110	Single valve

With pre-opening

<b>BPS1</b>	602003000*	Block with valve on port A
<b>BPS2</b>	602003000*	Block with valve on port B
<b>BPS3</b>	602003100*	Block with valves on ports A and B
<b>BPS</b>	XCAR605210	Single valve
<b>BPT</b>	XTAP627300	BP and BPS valves blanking plug

**4. P antishock valves** *page 57*

Cross return type, supplied with mounting block

TYPE	CODE	DESCRIPTION
<b>P1(D3-100)</b>	602001000*	Block with valve on port A
<b>P2(D3-100)</b>	602001000*	Block with valve on port B
<b>P3(D3-100)</b>	602001100*	Block with valves on ports A and B
<b>P(D2-60)</b>	5CAR211112	Single valve: range 40 to 100 bar / 580 to 1450 psi, standard setting 60 bar / 870 psi
<b>P(D3-100)</b>	5CAR211113	Single valve: range 80 to 200 bar / 1150 to 2900 psi, standard setting 100 bar / 1450 psi
<b>P(D4-200)</b>	5CAR211113	Single valve: range 180 to 315 bar / 2600 to 4600 psi, standard setting 200 bar / 2900 psi
<b>PT</b>	XTAP526430	Valve blanking plug (for configuration P1, P2)

**5. VM anti-schock+anti-cavitation valve** *page 59*Flange mounted type with **fixed setting** and fitted with mounting block.

TYPE	CODE	DESCRIPTION
<b>VM(50)</b>	5KIT326050	Setting 50 bar / 725 psi
<b>VM(60)</b>	5KIT326060	Setting 60 bar / 870 psi
<b>VM(70)</b>	5KIT326070	Setting 70 bar / 1010 psi
<b>VM(80)</b>	5KIT326080	Setting 80 bar / 1150 psi
<b>VM(90)</b>	5KIT326090	Setting 90 bar / 1300 psi
<b>VM(100)</b>	5KIT326100	Setting 100 bar / 1450 psi
<b>VM(125)</b>	5KIT326125	Setting 125 bar / 1800 psi
<b>VM(140)</b>	5KIT326140	Setting 140 bar / 2050 psi
<b>VM(160)</b>	5KIT326160	Setting 160 bar / 2300 psi
<b>VM(175)</b>	5KIT326175	Setting 175 bar / 2550 psi
<b>VM(190)</b>	5KIT326190	Setting 190 bar / 2750 psi
<b>VM(210)</b>	5KIT326210	Setting 210 bar / 3050 psi
<b>VM(230)</b>	5KIT326230	Setting 230 bar / 3350 psi
<b>VM(250)</b>	5KIT326250	Setting 250 bar / 3600 psi
<b>VM(260)</b>	5KIT326260	Setting 260 bar / 3750 psi
<b>VM(280)</b>	5KIT326280	Setting 280 bar / 4050 psi
<b>VM(300)</b>	5KIT326300	Setting 300 bar / 4350 psi
<b>VMT</b>	XTAP221340	Valve blanking plug
<b>Kit VM</b>	5CO2820020	Mounting block kit

**6. V anti-schock+anti-cavitation valve** *pag. 61*

Set of valves fitted with mounting block.

TYPE	CODE	DESCRIPTION
<b>Kit V</b>	5CO2820010	Mounting block kit
<b>T</b>	XTAP524280	Valve blanking plug
<b>C</b>	5KIT406110	Anti-cavitation valve

Anti-shock valves

<b>P(G2)</b>	5KIT206112	Range 60 to 125 bar / 870 to 1800 psi standard setting 80 bar / 1150 psi
<b>P(G3)</b>	5KIT206113	Range 80 to 200 bar / 1150 to 2900 psi standard setting 120 bar / 1750 psi
<b>P(G4)</b>	5KIT206114	Range 160 to 250 bar / 2300 to 3600 psi standard setting 200 bar / 2900 psi

Anti-shock + anti-cavitation valves

<b>U(G2)</b>	5KIT305112	Range 40 to 100 bar / 580 to 1450 psi standard setting 80 bar / 1150 psi
<b>U(G3)</b>	5KIT305113	Range 80 to 200 bar / 1150 to 2900 psi standard setting 120 bar / 1750 psi
<b>U(G4)</b>	5KIT305114	Range 160 to 315 bar / 2300 to 4600 psi standard setting 200 bar / 2900 psi

**7. Flow control valves** *page 65*

Flow control on every section; with auxiliary inlet

TYPE	CODE	DESCRIPTION
<b>VD11</b>	2S0PP10002000	Fine regulation from 3 to 30 l/min
<b>VD12</b>	2S1636020211	As VD11, one turn with detent
<b>VD13</b>	2S0PP10002002	12VDC proportional solenoid valve
<b>Kit VD1</b>	5CO2822010*	Mounting block kit

NOTE - Valve setting at points 1-2-4-5-6 are referred to 10 l/min flow.

- (\*) Codes are referred to **BSP** threads.

Service and auxiliary valves

VS relief valve

It's suggested for flow up to 25 l/min, and it's mounted on parallel body to limitate the pressure, at lower value than main relief valve (min. gap 20 bar / 290 psi), on downstream section.

It's in parallel with flow trough and it works only with single operation.

VS ( G 3 - 100 )

- Pressure setting in bar (standard 100 bar / 1450 psi)
- Spring type
- Adjustment type (G, H)

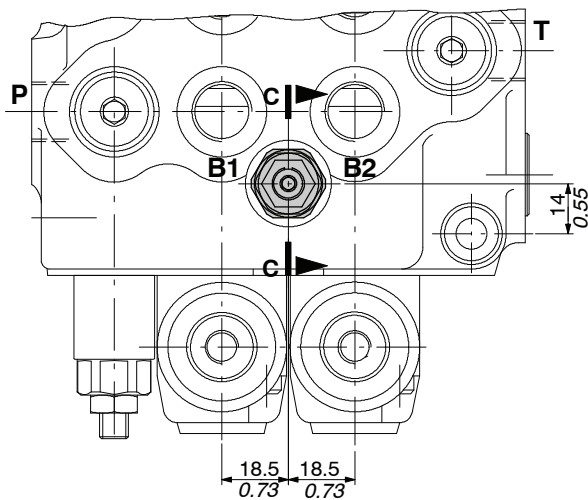

Adjustment type

G: with screw

H: valve set and locked

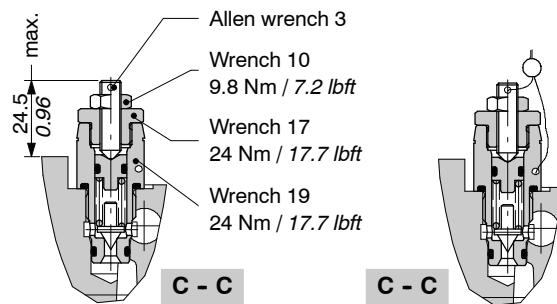

Performance data

Hydraulic circuit

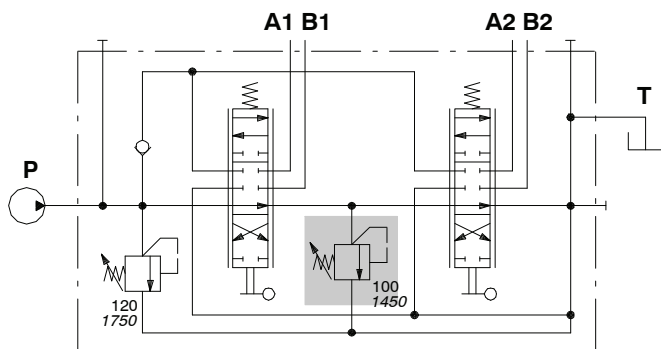

Description example:

SD5/2-P(KG3-120)/18L/VS(G3-100)/18L/AET-PSA

Spring nr. 3 (blue band)

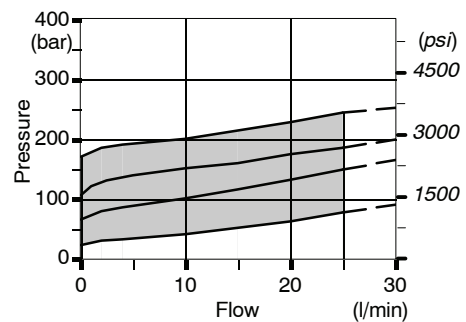

Time response

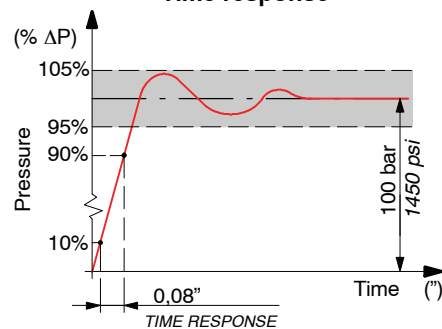

VST: valve blanking plug

Allen wrench 6  
42 Nm / 31 lbft

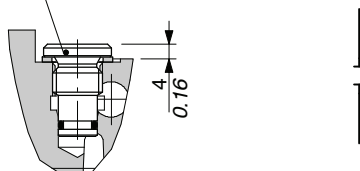

VSC relief valve

It's flange mounted on parallel body on the opposite side of working ports, the function to limit the pressure, at lower value than main relief valve (min. gap 20 bar / 290 psi) on downstream sections.

It's in parallel with flow through line and it works only with single operation.

It needs a dedicated body with extra machining: for production requirements, the block (2) is flanged (1) before the final honing of spool hole, while the valve (3) is mounted during final assembling phase.

For information contact Sales Department.

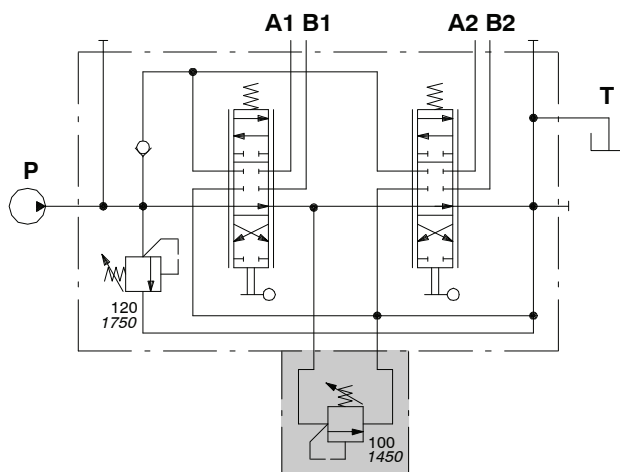
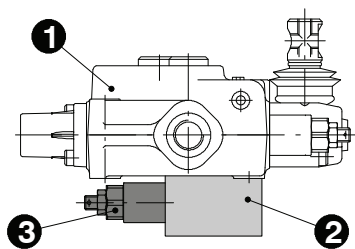

VSC ( J G 3 - 100 )

Standard setting in bar  
(for value see page 53)

Adjustable spring type (2, 3, 4).

Adjustment type (G, H).

Description example:

SD5/2-P(JG3-120)/18L/VSC(JG3-100)/18L/AET

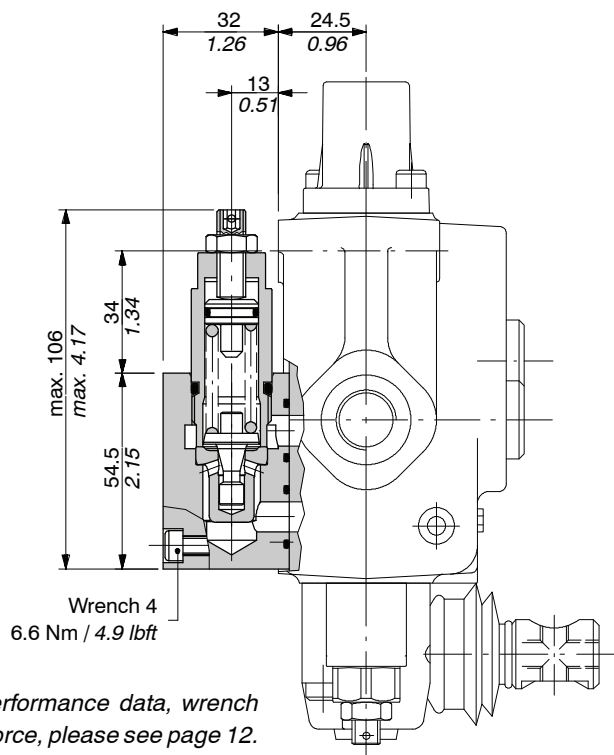
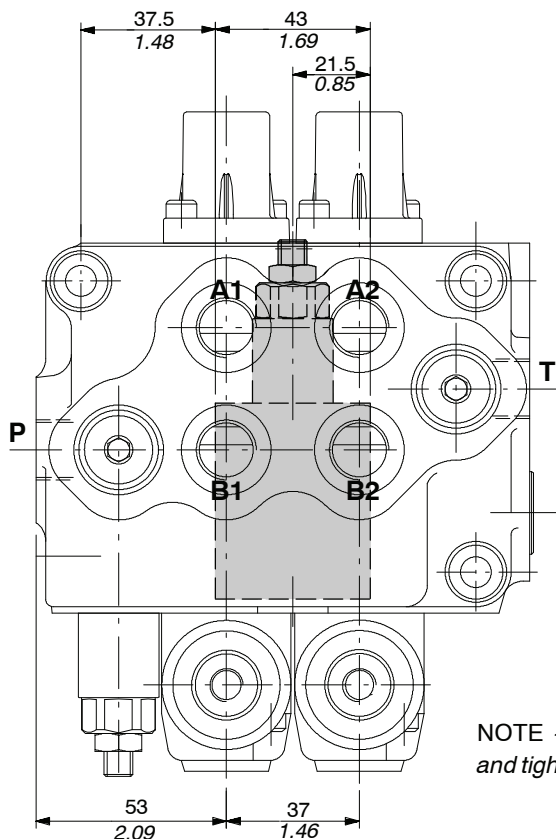

NOTE - For performance data, wrench and tightening force, please see page 12.

Service and auxiliary valves

BP, BPS pilot check valves

Cast iron block with pilot check valves.

BPS 1

- 1 mounted on port A.
- 2 mounted on port B.
- 3 mounted on ports A and B.
- BP direct type
- BPS with pre-opening

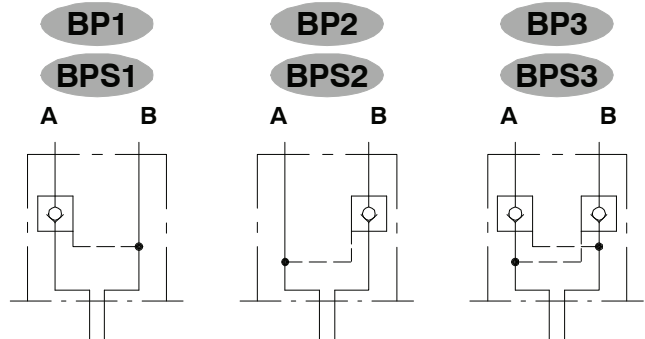

BP1 configuration

Example of pressure on port A and port B to tank

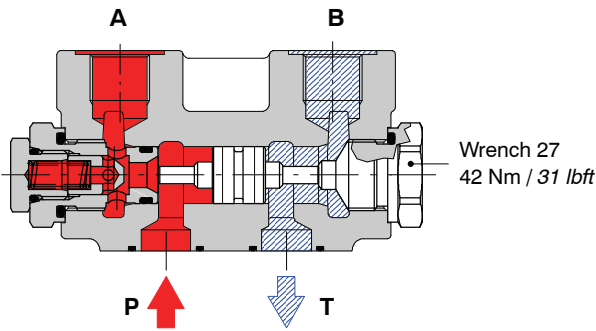

BP3 configuration

Example of pressure on port A and port B to tank

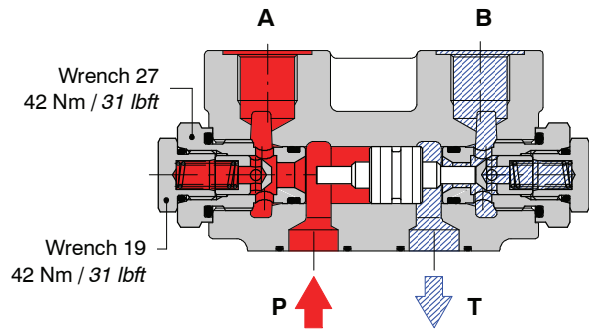

Example of pressure on port B and port A to tank

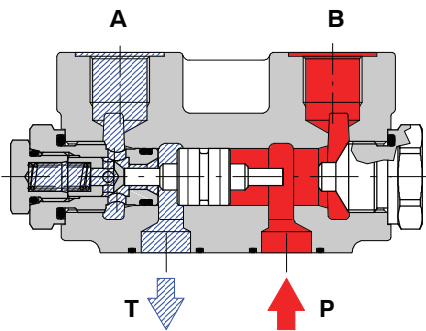

Example of pressure on port B and port A to tank

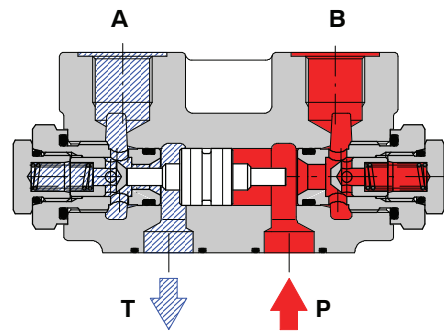

Performance data

BP valve pressure drop

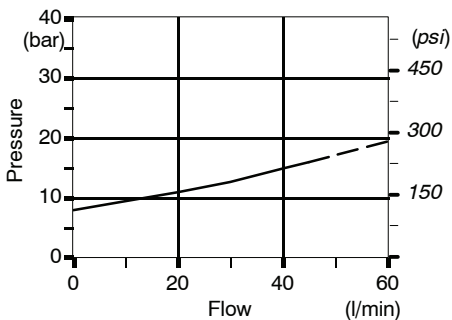

Type	Pilot ratio	
	With pre-opening	Main
BP	/	1 : 5.3
BPS	1 : 16	1 : 3.2

BPS valve pressure drop

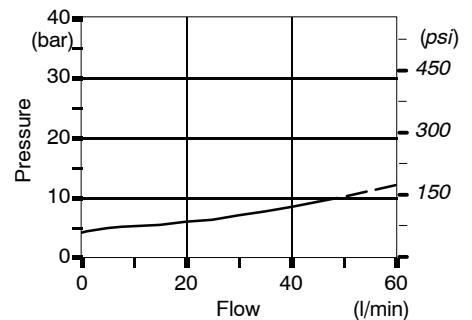



**P anti-shock valves with cross return**

Cast iron block with antishock valves.

**P 1 ( D 3 - 100 )**

- Standard setting in bar (for value see page 43)
- Spring type (2, 3, 4).
- Adjustment with blind nut (D).
- 1 mounted on port A.
- 2 mounted on port B.
- 3 mounted on ports A and B.

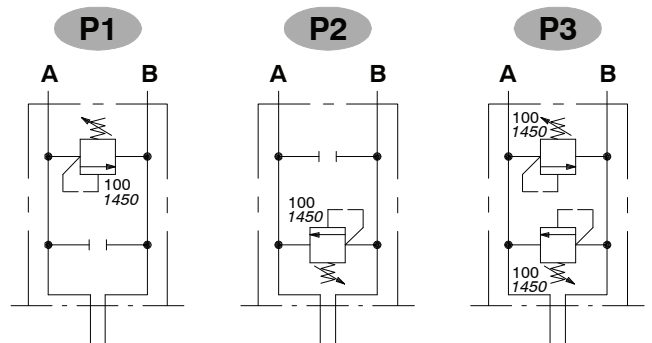

**P1 configuration**

Example of pressure on port A and port B to tank

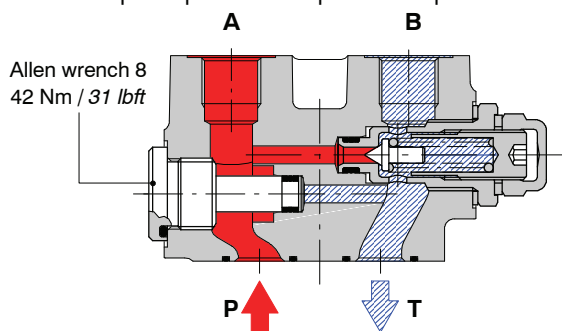

**P3 configuration**

Example of pressure on port B and port A to tank

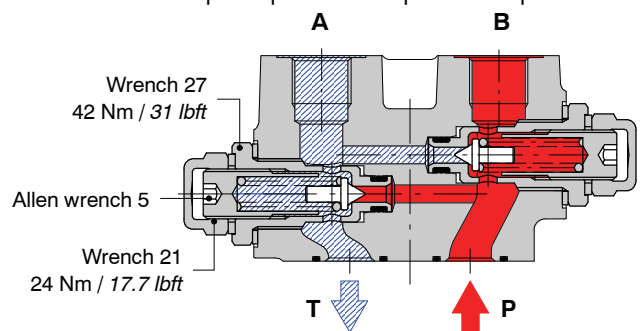

**Performance data**

**Spring nr. 2 (green band)**

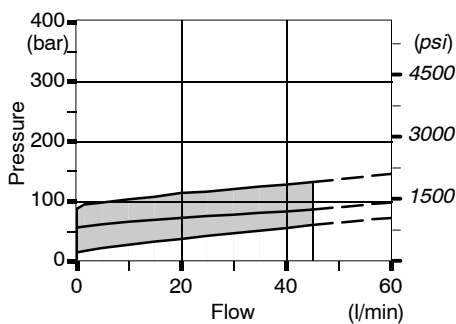

**Spring nr. 3 (blue band)**

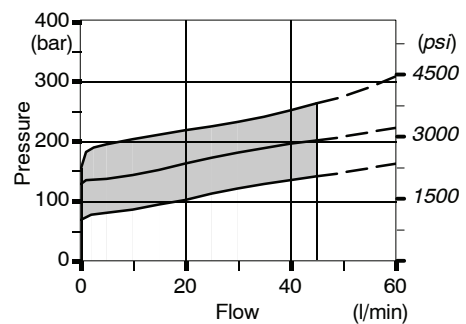

**Spring nr. 4 (red band)**

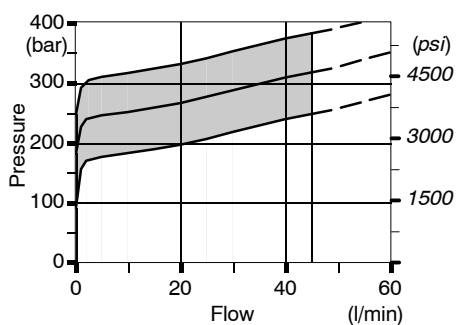

**Time response**

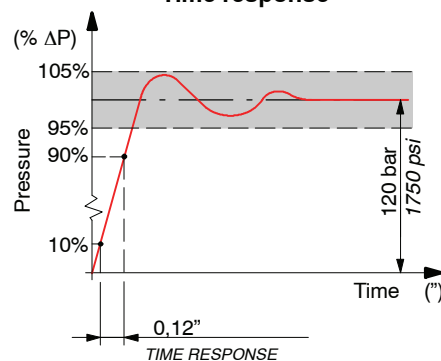

Service and auxiliary valves

Mounting example for valves type P and BP, BPS

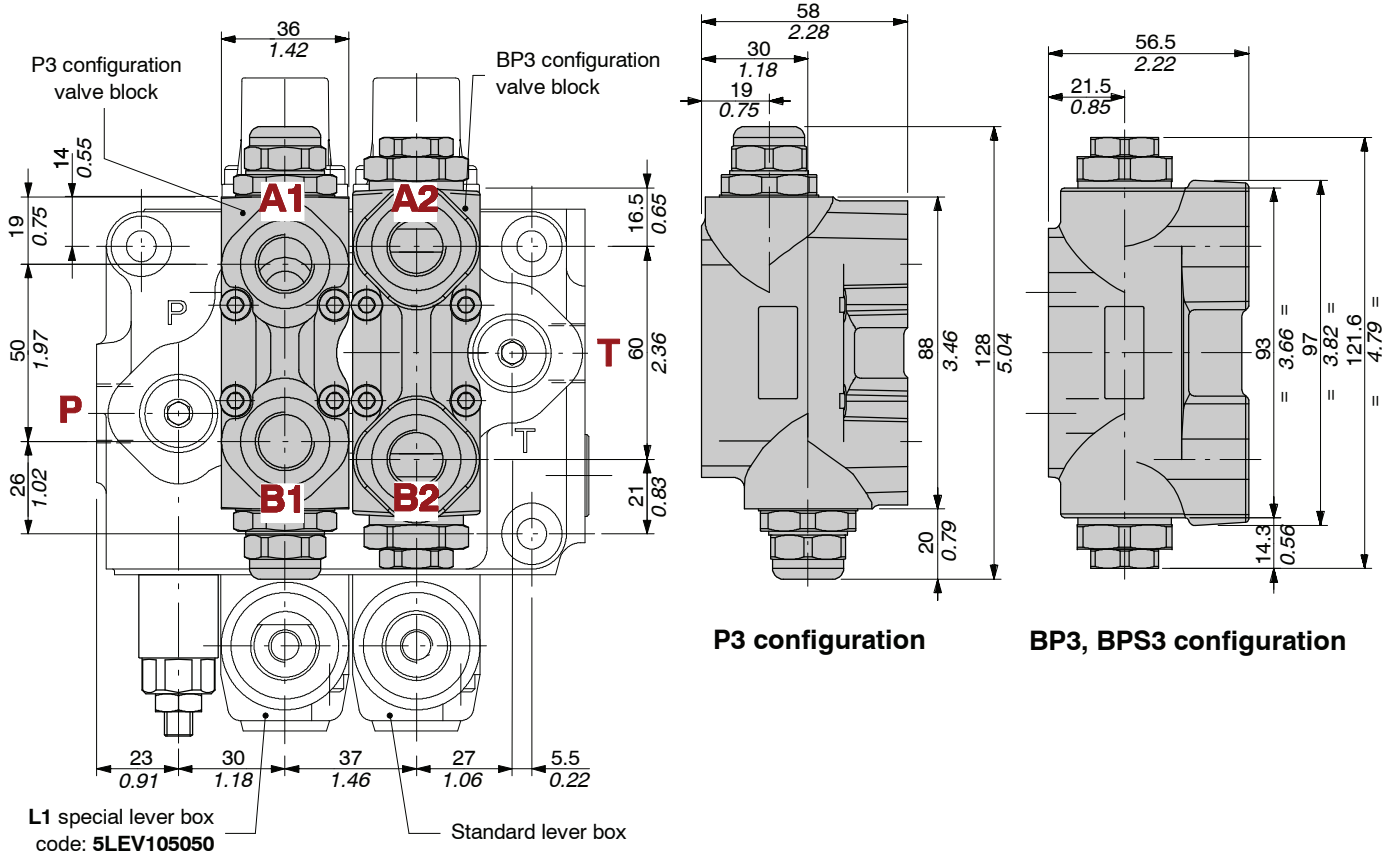

Example of extra machining on directional valve body

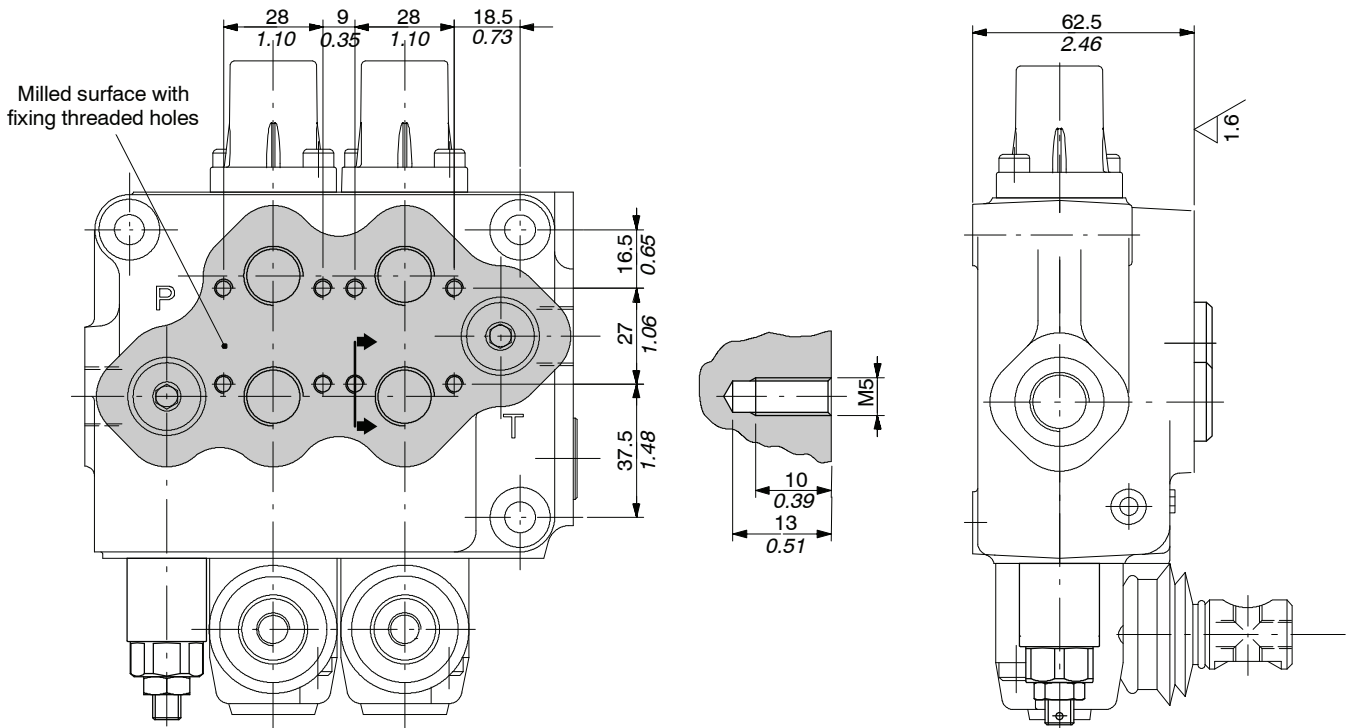

**VM anti-shock and anti-cavitation**

They are flange mounted on the opposite side of working ports, connected in parallel with A and B ports and with outlet on T port. It needs a dedicated body with extra machining: for production requirements, the block (2) is flanged on body (1) before the final honing of spool hole, while the valve (3) is mounted during final assembling phase. For information contact Sales Department.

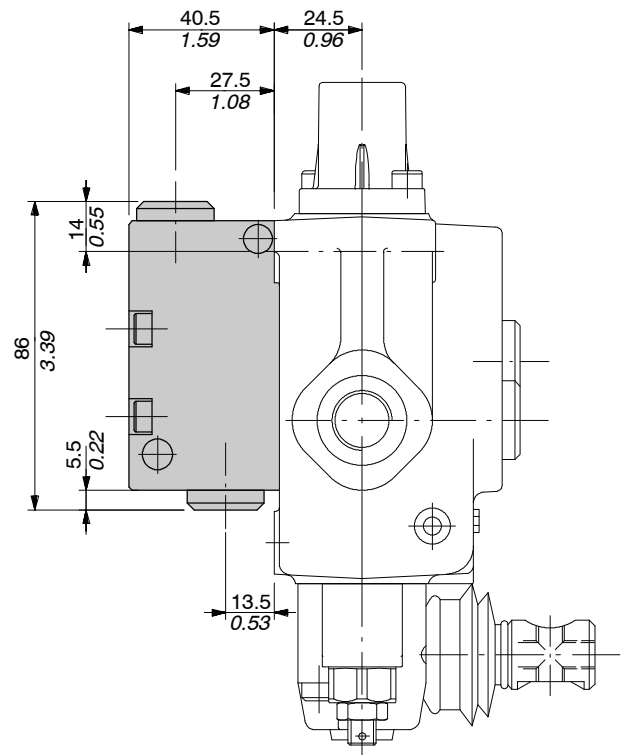
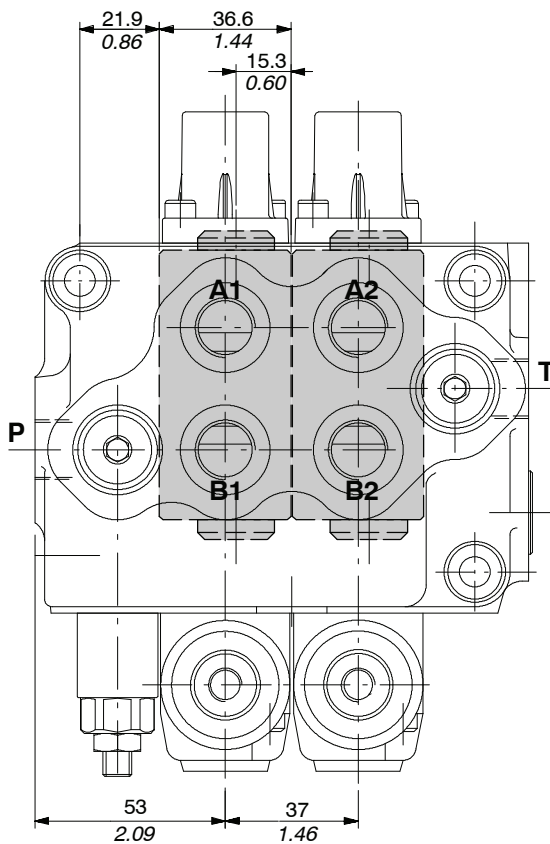
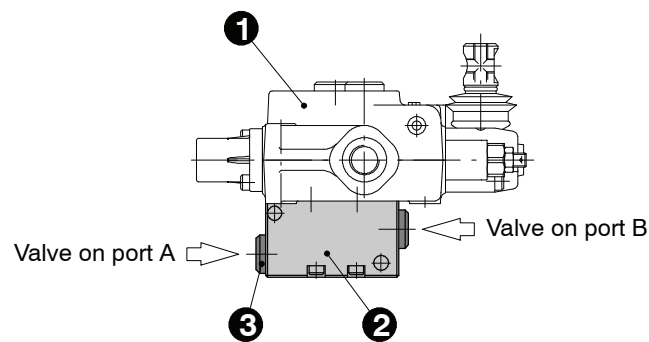

Service and auxiliary valves

VM anti-shock and anti-cavitation

VM 1 (100)

- Valve setting in bar
- 1 mounted on port A
- 2 mounted on port B
- 3 mounted on ports A and B

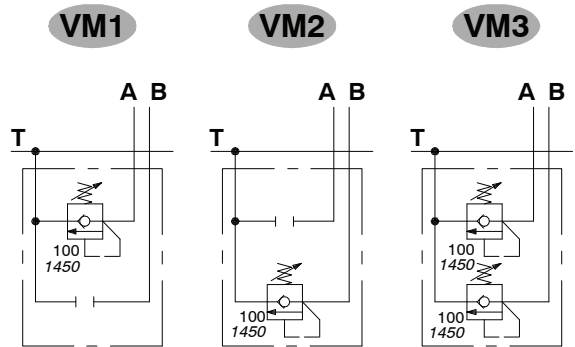

Example of VM1 configuration

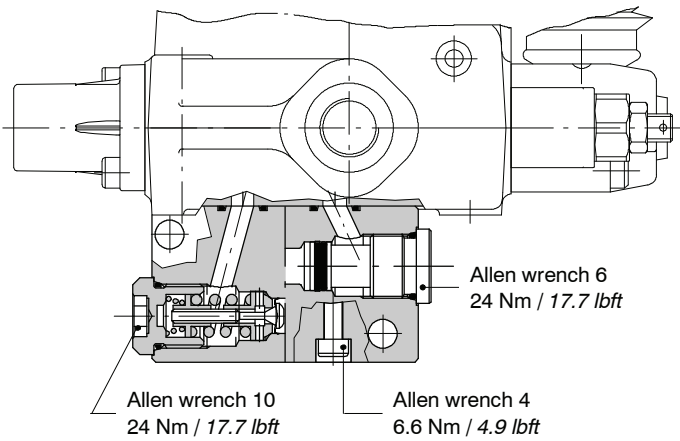

Pressure-flow diagram

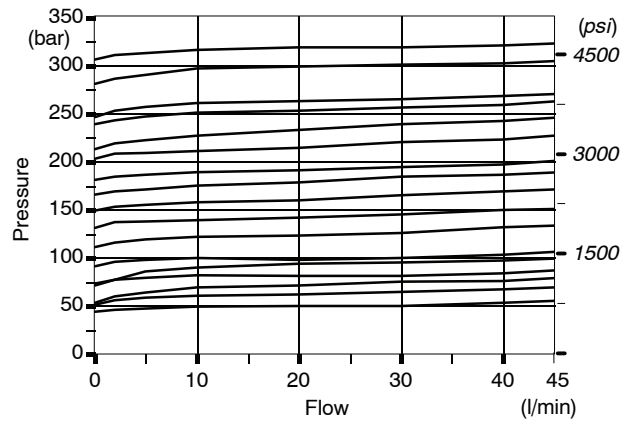

**V anti-shock and anti-cavitation**

They are anti-shock (VP), anti-shock and anti-cavitation (VU) and anti-cavitation (VC) service valves, flange mounted on the opposite side of working ports connected in parallel with A and B ports.

They need a dedicated body with extra machining: for production requirements, the blocks (2) are flanged on body (1) before the final honing of spool hole, while the valves (3) are mounted during final assembling phase.

For information contact Sales Department.

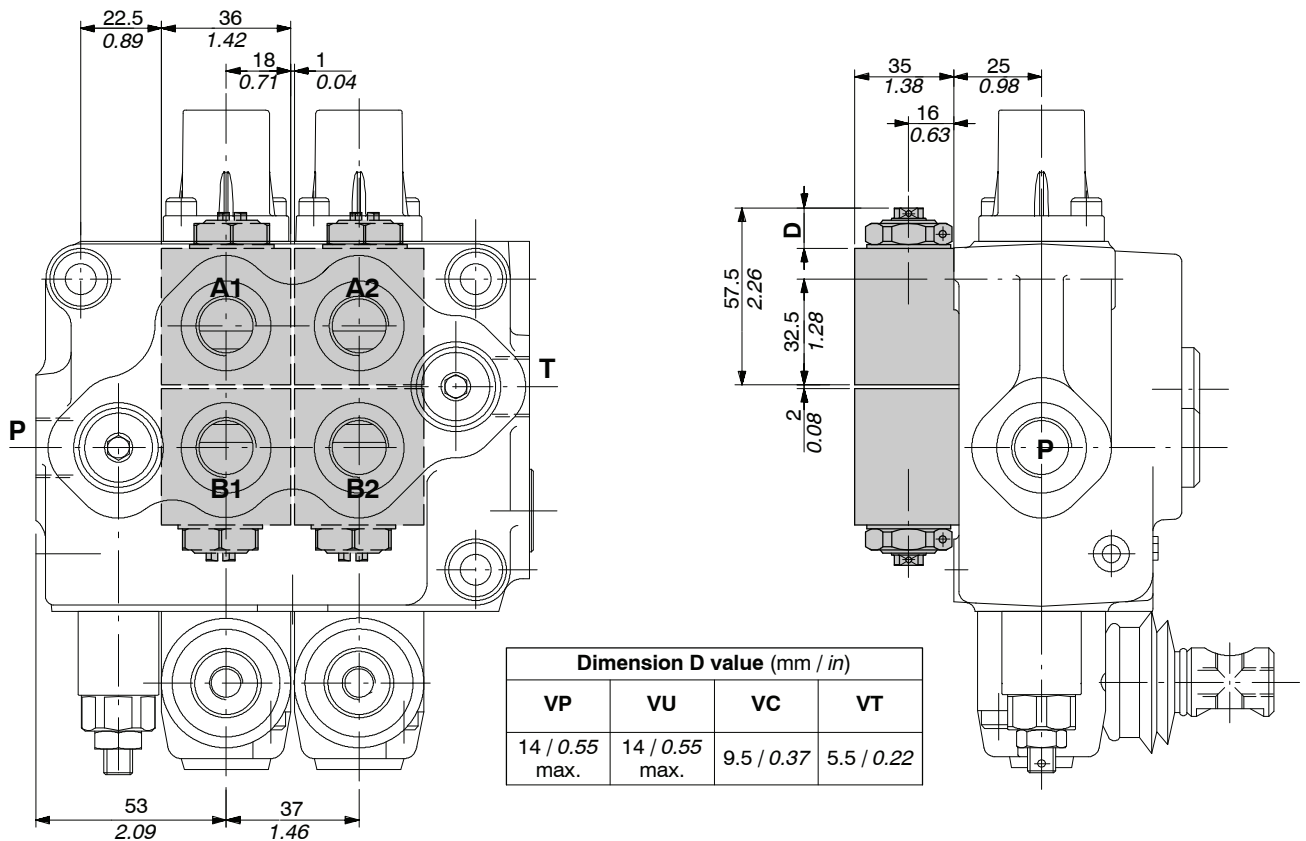
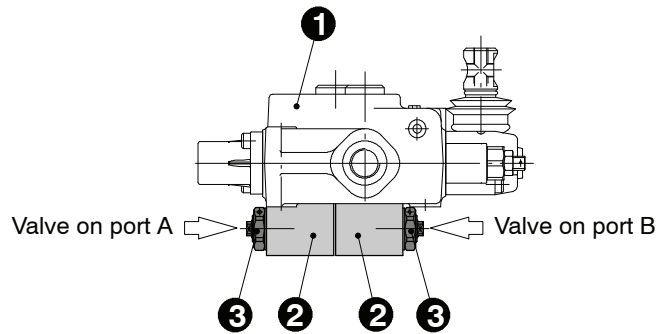

Service and auxiliary valves

V anti-schock+anti-cavitation valves

**Anti-shock valve**

**VP 1 ( G 3 - 100 )**

Standard setting in bar  
(for value see page 53)

Spring type **(2, 3, 4)**.

Adjustment type **(G, H)**.

- 1 mounted on port A.
- 2 mounted on port B.
- 3 mounted on ports A and B.

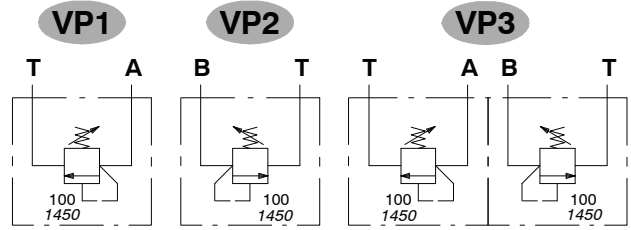

Adjustment type

**G: with screw**

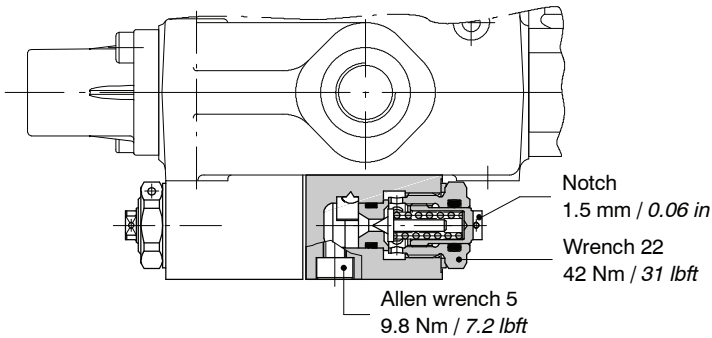

**H: valve set and locked**

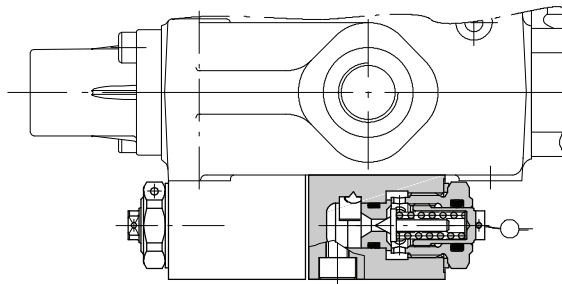

Performance data

**Spring nr. 2 (green band)**

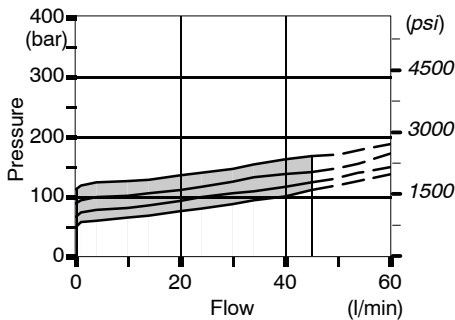

**Spring nr. 3 (blue band)**

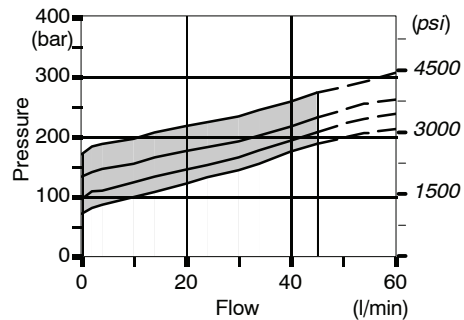

**Spring nr.4 (red band)**

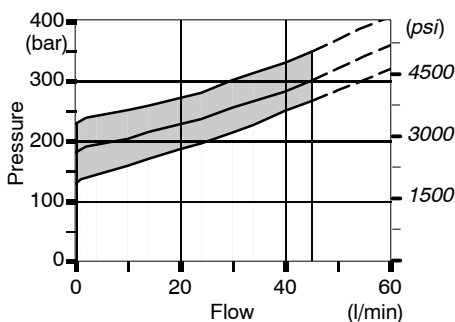

**Time response**

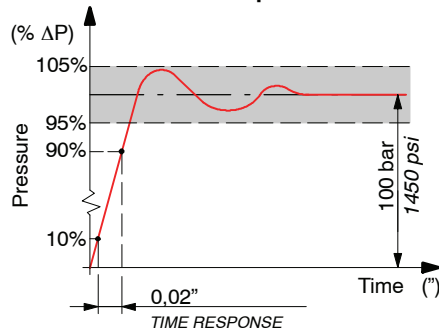

V anti-shock and anti-cavitation

Anti-shock + anti-cavitation valve

VU 1 ( G 3 - 100 )

- Standard setting in bar (for value see page 53)
- Spring type (2, 3, 4).
- Adjustment type (G, H).
- 1 mounted on port A.
- 2 mounted on port B.
- 3 mounted on ports A and B.

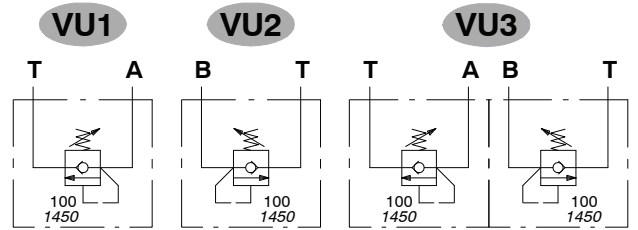

Adjustment type

G: with screw

H: valve set and locked

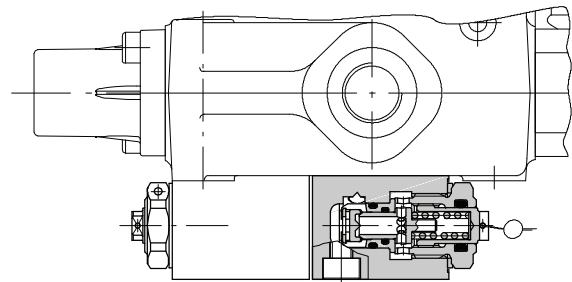
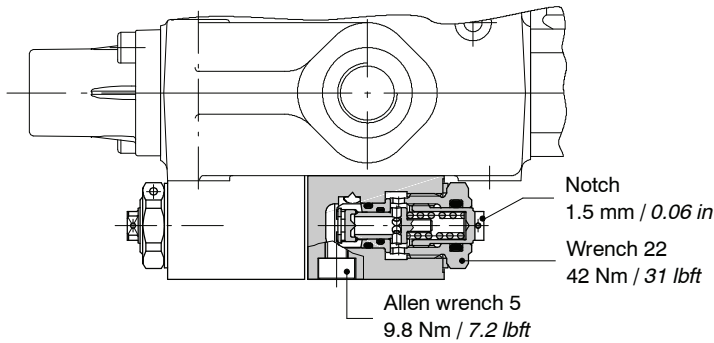

Performance data

Spring nr. 2 (green band)

Spring nr. 3 (blue band)

Spring nr. 4 (red band)

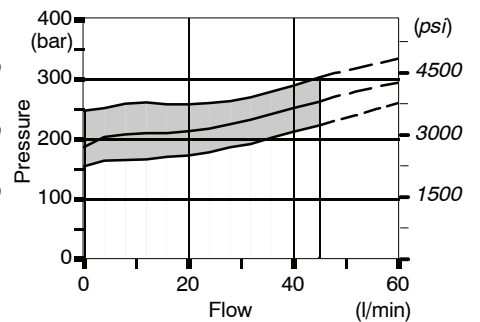
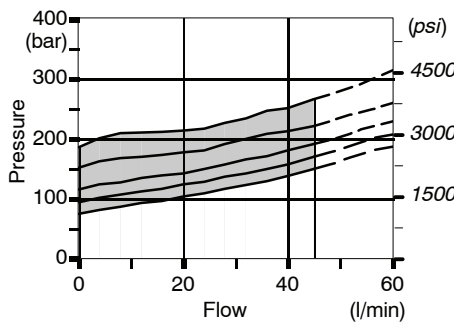
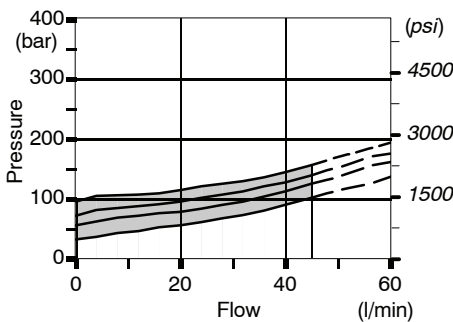

Pressure drops

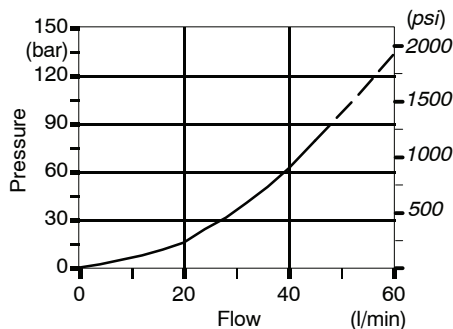

Time response

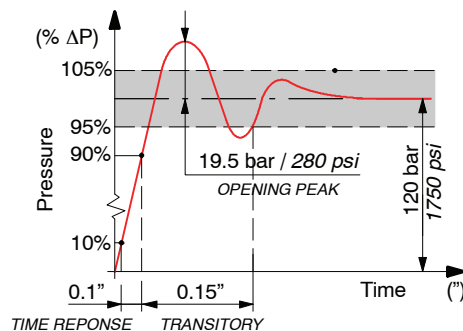

Service and auxiliary valves

V anti-shock and anti-cavitation

Anti-cavitation valve

VC 1

- 1 mounted on port A.
- 2 mounted on port B.
- 3 mounted on ports A and B.

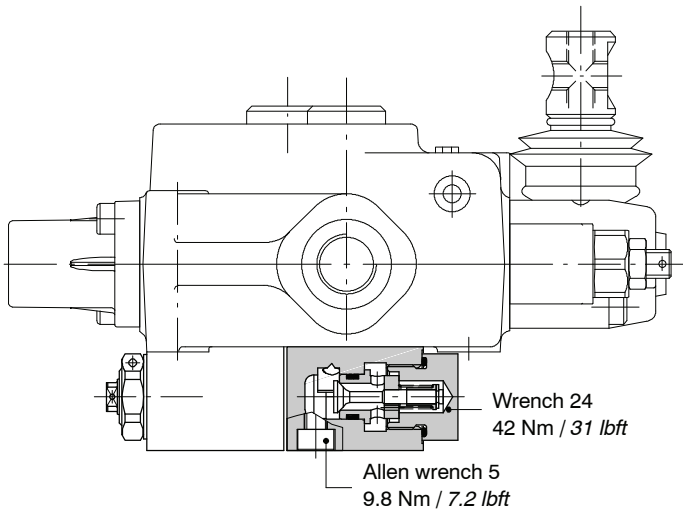
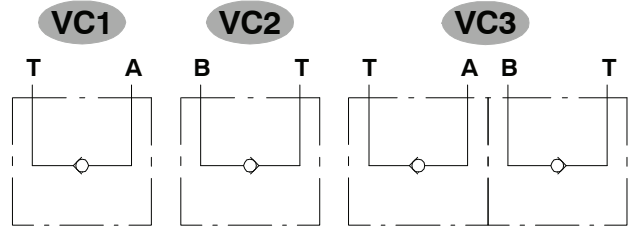

Pressure drop

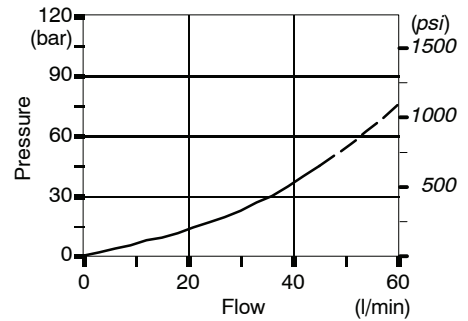

Valve blanking plug

VT 1

- 1 mounted on port A.
- 2 mounted on port B.
- 3 mounted on ports A and B.

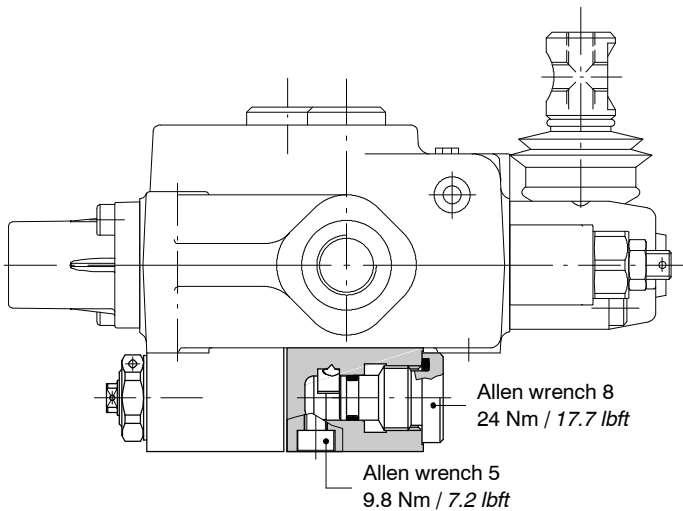
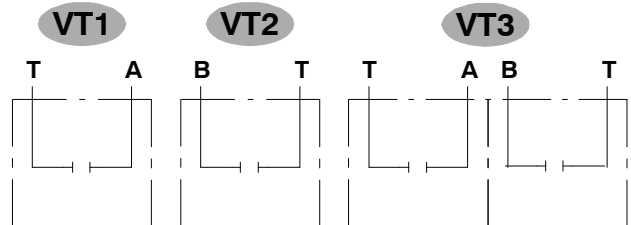



**VD1 flow control valves**

Block with pressure compensated 3-way flow control valve, to be flange mounted on body with parallel circuit.

The cavity is oriented toward lever side.

The flow is regulated on every working section while the exceeding flow goes to tank: max. regulated flow 30 l/min (with inlet on P1 port).

It needs a dedicated body with extra machining: for production requirements, the block (2) is flanged (1) before the final honing of spool hole, while the valve (3) is mounted during final assembling phase.

For information contact Sales Department.

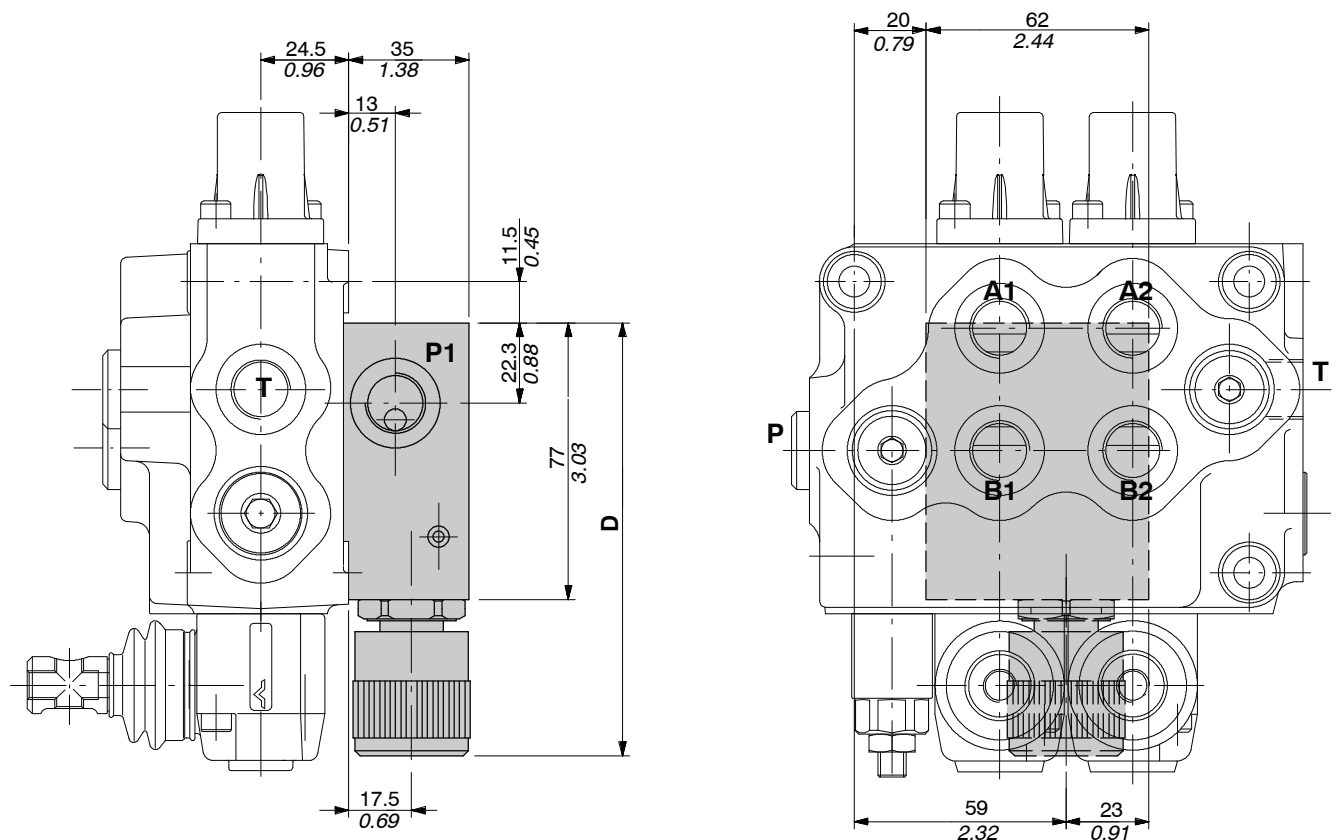
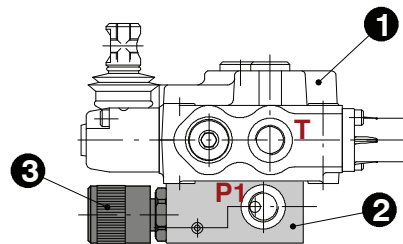

Dimension D value (mm / in)		
VD11	VD12	VD13
121 / 4.76	171.5 / 6.75	171.5 / 6.75

**Service and auxiliary valves**

**VD1 flow control valves**

**Manual control**

**VD11: continuous fine regulation**

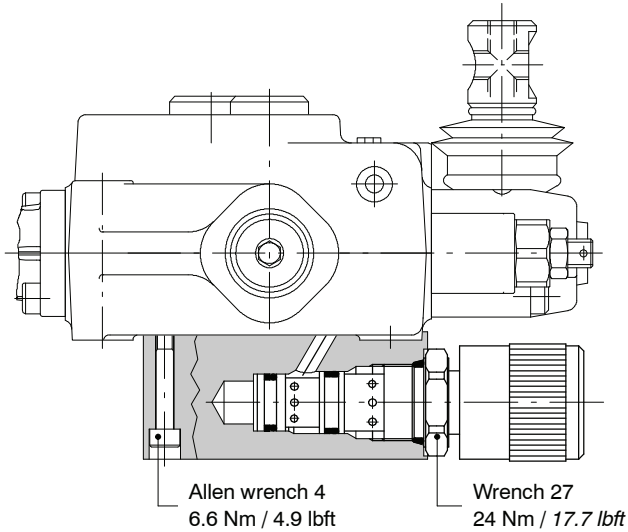

Description example: SD5/2-P(JG3-120)VD11/18L/18L/AET

**VD12: one turn with detent handknob regulated**

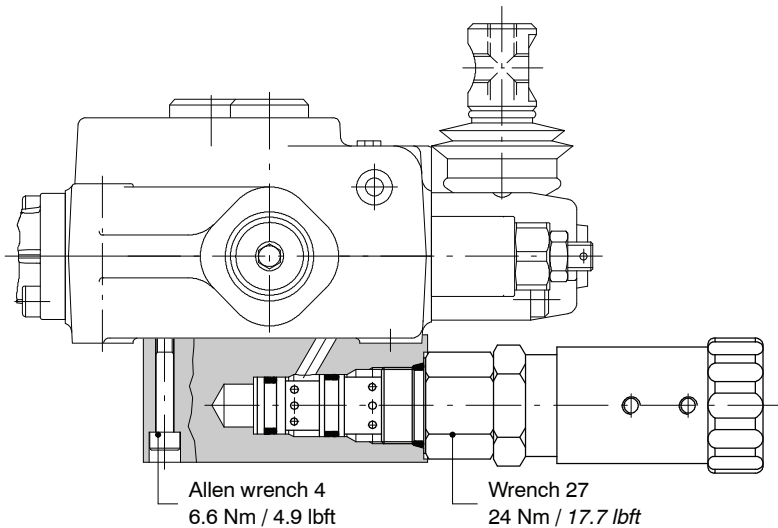

Description example: SD5/2-P(JG3-120)VD12/18L/18L/AET

**Hydraulic circuit**

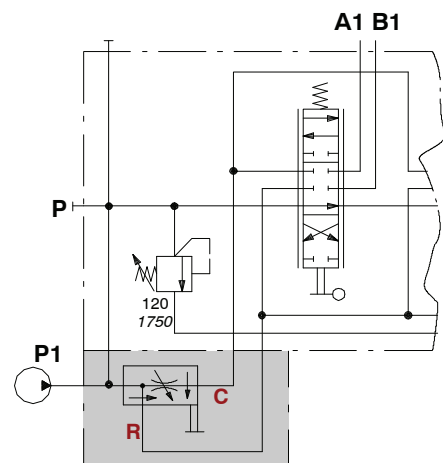

VD1 flow control valves

VD13 with proportional solenoid control

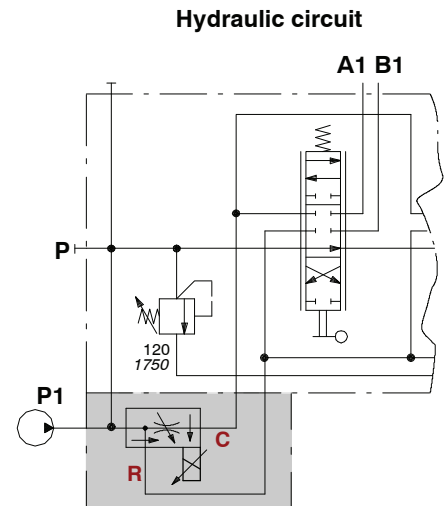
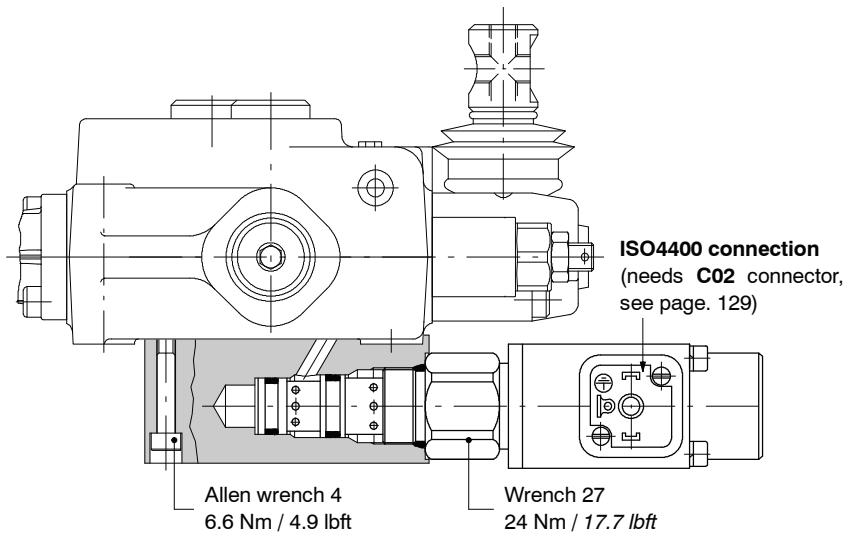

Description example: SD5/2-P(JG3-120)VD13/18L/18L/AET

Proportional solenoid flow control valve connection

It's shows a configuration with push-button panel type UPA.

For information contact Sales Department.

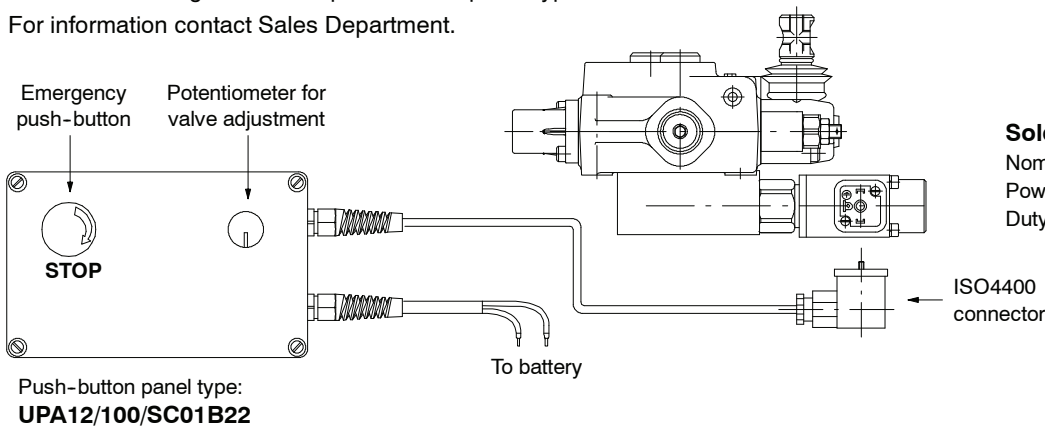

Solenoid operating features

Nominal voltage ..... : 12 VDC  
Power rating ..... : 28 W  
Duty cycle ..... : 100%

Performance data

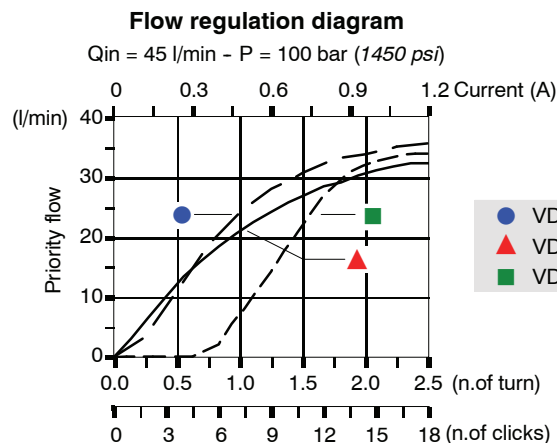
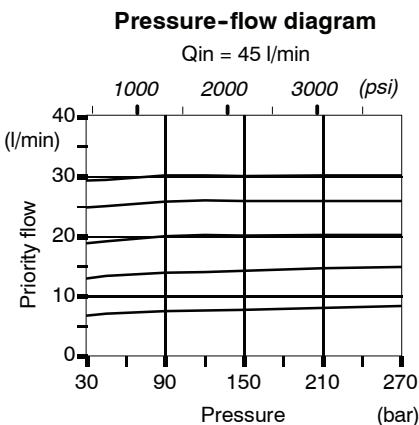



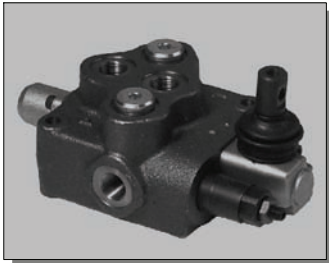

**SD5/1 - N** ..... page 70

It's available only with one working section and it can be used in hydraulic circuits where carry-over doesn't required.

- For controls, spool positioning and valves, refer to directional valve with parallel circuit.



**SD5/1 - D** ..... page 71

It's available only with one working section and it can be used in hydraulic circuits where carry-over is required.

- For controls and spool positioning refer to directional valve with parallel circuit.
- Configurations with service and auxiliary valves aren't available



**SD5-S: with series circuit** ..... page 72

Available from 2 to 6 sections, it can be used in systems with one downstream section from series connection must work with upstream ones at the same time.

- On the same body are possible more than one connection.
- It's not available the carry-over circuit.
- For controls, spool positioning and valves, refer to directional valve with parallel circuit.



**SD5-SP: with tandem circuit** ..... page 74

Available from 2 to 6 sections, for security reasons it can be used in systems which is required to prohibit engagement of downstream sections from tandem connection when the upstream sections are working.

- On the same body are possible more than one connection.
- For controls, spool positioning and valves, refer to directional valve with parallel circuit.

### Dimensional data

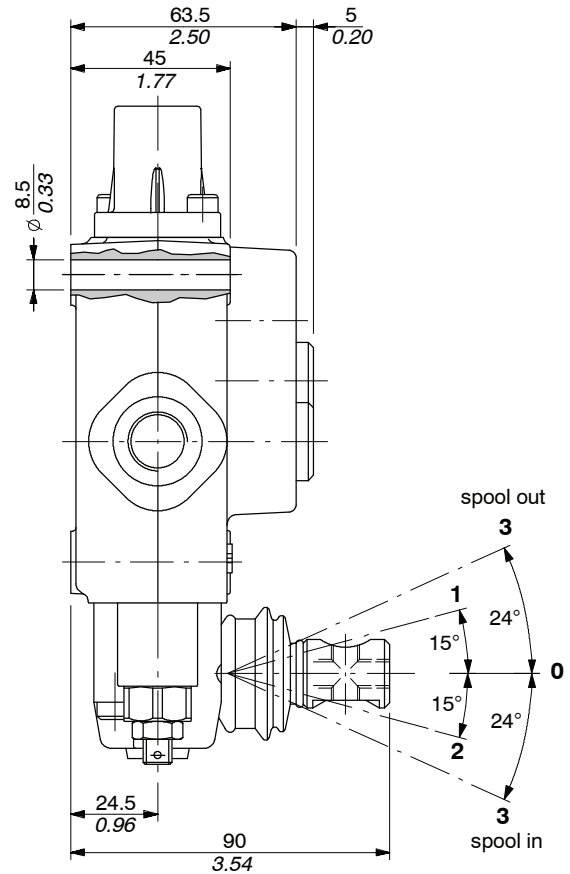
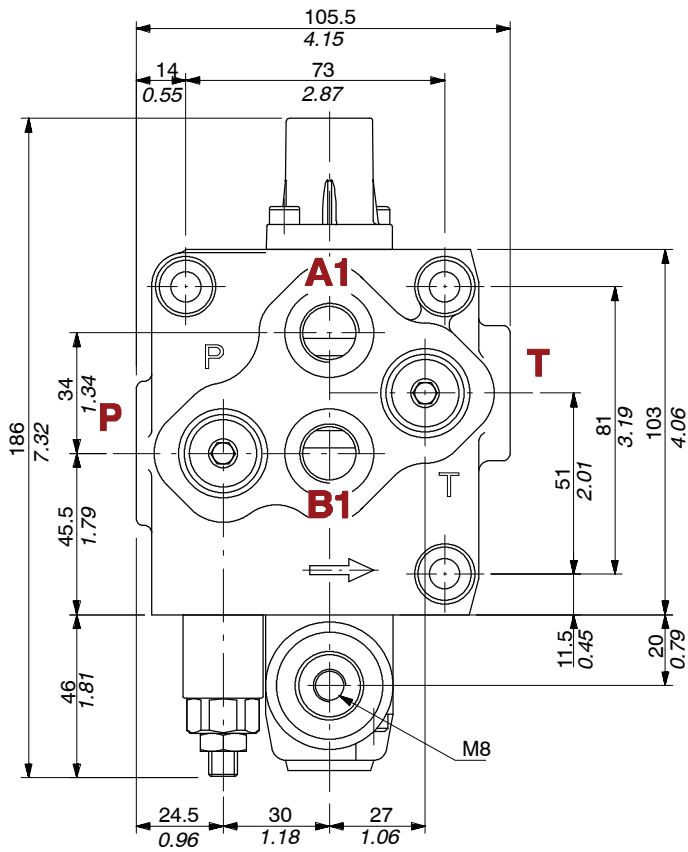

### Hydraulic circuit

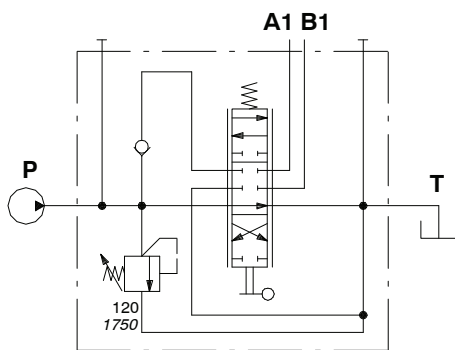

Description example:  
SD5/1-N(JG3-120)/18L  
Code: 102110033

### Performance data

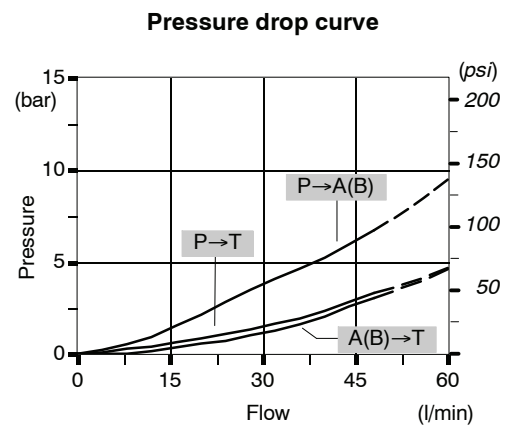

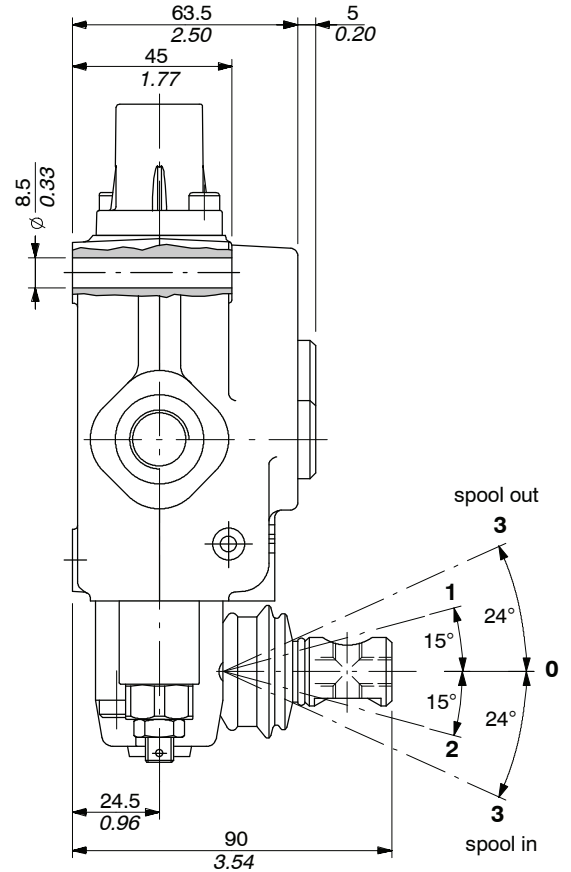
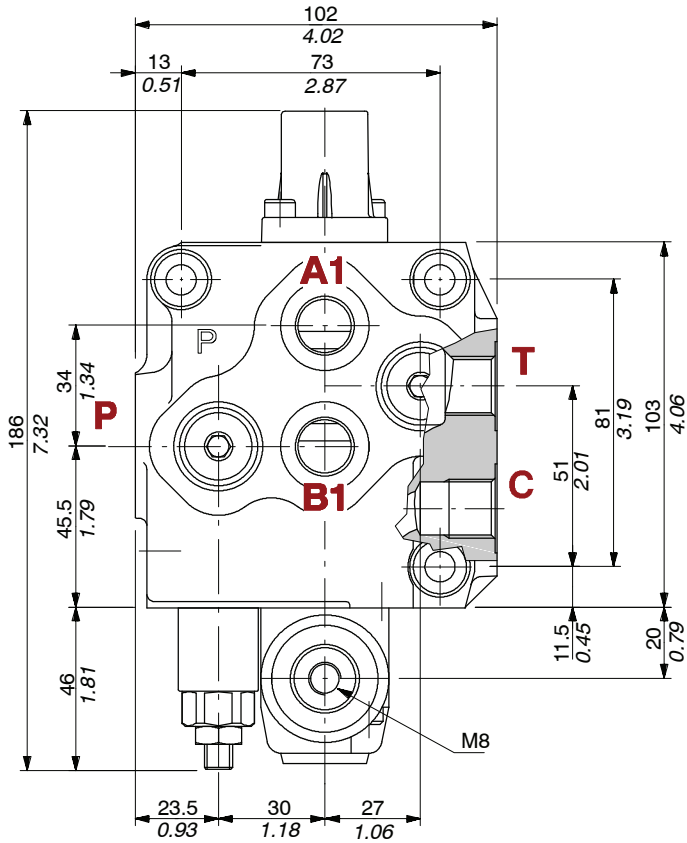

Hydraulic circuit

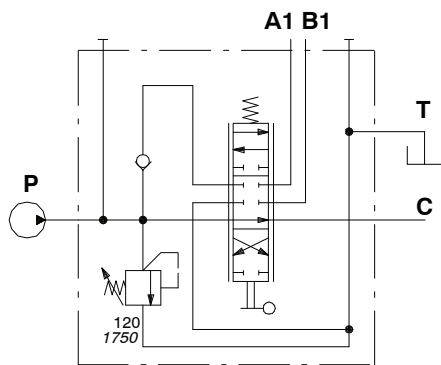

Description example:  
SD5/1-D(JG3-120)/18L  
Code: 102160027

Performance data

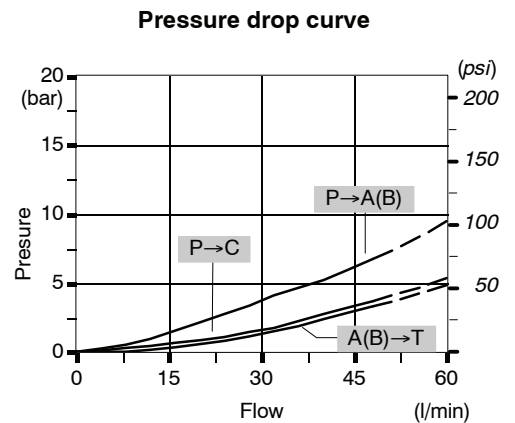

## Dimensional data

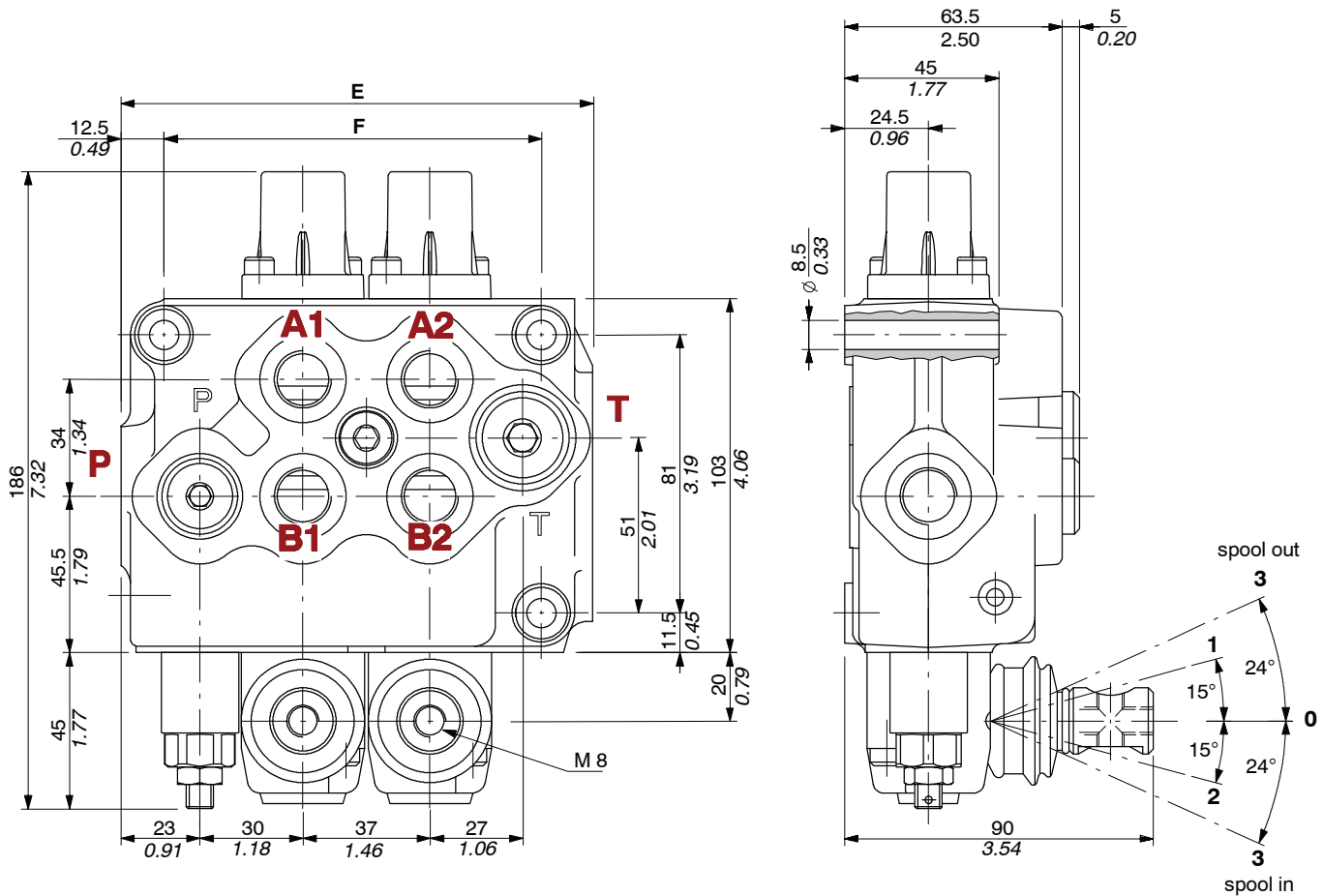

TYPE	E		F		Weight	
	mm	in	mm	in	kg	lb
SD5/2-S	137.5	5.41	110	4.33	5.2	11.4
SD5/3-S	174.5	6.87	147	5.79	6.9	15.2
SD5/4-S	211.5	8.33	184	7.24	8.1	17.9

TYPE	E		F		Weight	
	mm	in	mm	in	kg	lb
SD5/5-S	248.5	9.78	221	8.70	10.1	22.3
SD5/6-S	285.5	11.2	258	10.2	11.7	25.8



The description of SD5 valve with series circuit is marked with letter "S" and one figure which indicate the downstream sections from series connection.

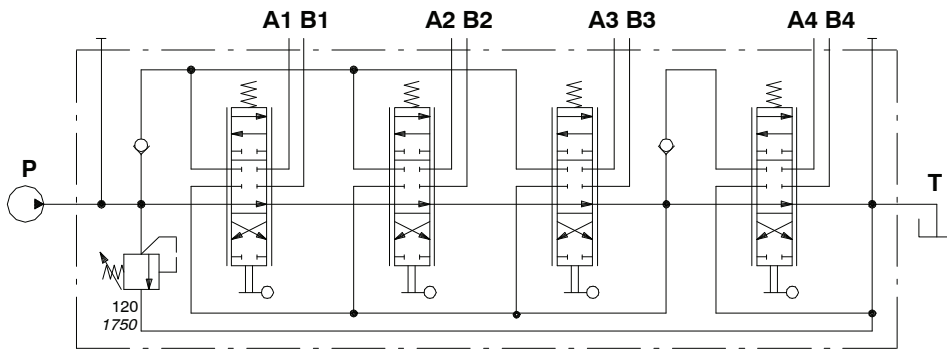

Description example: SD5/4-S1(JG3-120)/18L/18L/18L/18L

Code: 1024B0027 \*

Available body kits \*

CODE	DESCRIPTION
5KC1153040	SD5/2-S1
5KC1253003	SD5/3-S1
5KC12D3000	SD5/3-S1+1
5KC1283003	SD5/4-S1
5KC12E3000	SD5/4-S1+1+1
5KC1324033	SD5/5-S1
5KC1073001	SD5/5-S1+1+1+1
5KC13A3000	SD5/5-S2+1
5KC1363003	SD5/6-S1

Include body, seals and load check valves.

NOTE (\*) - Codes are referred to **BSP** thread.

Performance data

Pressure drop P→T

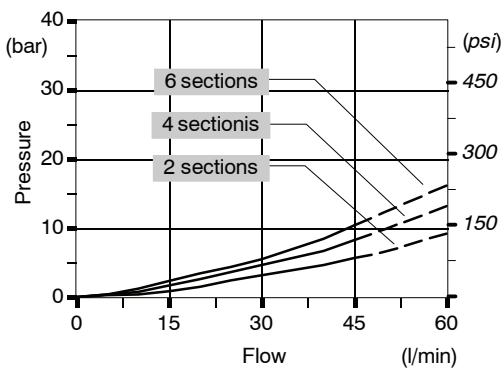

Pressure drop P→A(B)

on 6 sections directional valve

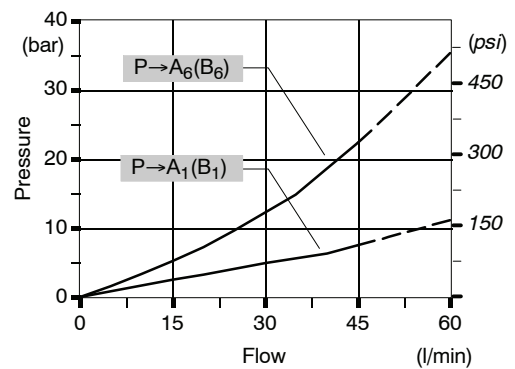

Pressure drop A(B)→T

on 6 sections directional valve

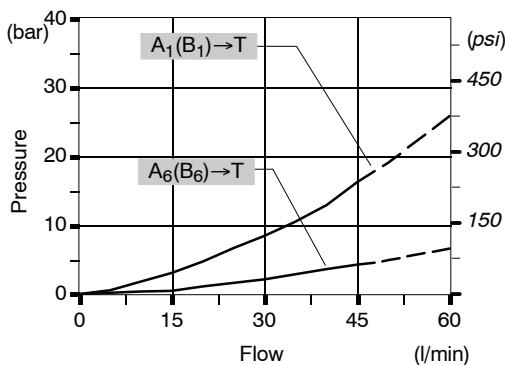

Pressure drop

between port A(B) before series connection and port A(B) after

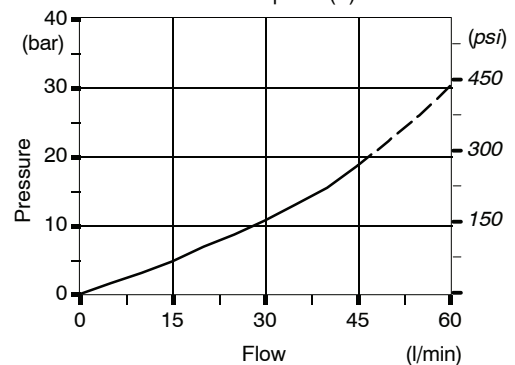

## Dimensional data

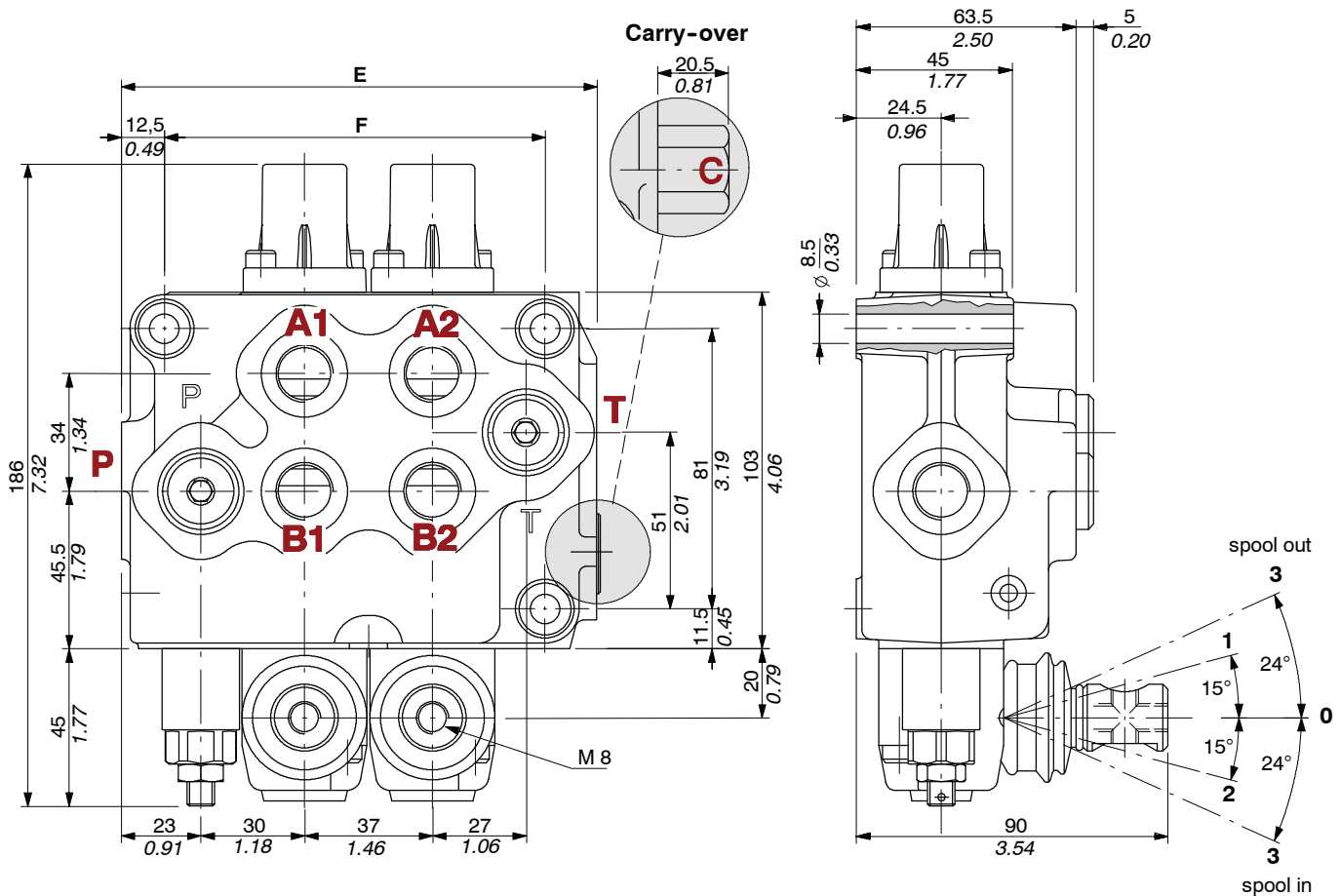

TYPE	E		F		Weight	
	mm	in	mm	in	kg	lb
SD5/2-SP1	137.5	5.41	110	4.33	4.8	10.6
SD5/3-SP2	174.5	6.87	147	5.79	6.7	14.8
SD5/4-SP3	211.5	8.33	184	7.24	8.1	17.6

TYPE	E		F		Weight	
	mm	in	mm	in	kg	lb
SD5/5-SP4	248.5	9.78	221	8.70	10.2	22.5
SD5/6-SP5	285.5	11.2	258	10.2	11.3	24.9
SD5/7-SP6	322.5	13.1	295	11.6	12.7	28

Hydraulic circuit

The description of SD5 valve with tandem circuit is marked with letters "SP" and one figure which indicate the downstream sections from tandem connection.

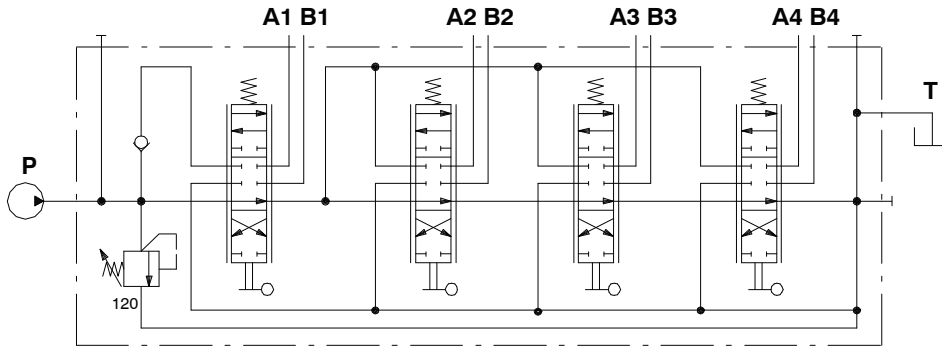

Description example: SD5/4-**SP3**(JG3-120)/18L/18L/18L/18L/AET  
Code: 1024A0016 \*

Available body kits \*

CODE	DESCRIPTION
5KC1183000	SD5/2-SP1
5KC12G3000	SD5/3-SP2
5KC1303000	SD5/4-SP1
5KC12H3000	SD5/4-SP1+1
5KC12I3000	SD5/4-SP2+1
5KC1293000	SD5/4-SP3
5KC13D3000	SD5/5-SP2+2
5KC1343000	SD5/5-SP3+1
5KC1333000	SD5/5-SP4
5KC1393000	SD5/6-SP3+1
5KC13Y3000	SD5/6-SP3+2
5KC1373000	SD5/6-SP5
5KC13I3000	SD5/7-SP3+1
5KC13G3000	SD5/7-SP4
5KC13L3000	SD5/7-SP5+1
5KC13F3000	SD5/7-SP6

Include body, seals and load check valve.

NOTE (\*) - Codes are referred to **BSP** threads.

Performance data

Pressure drop P→T

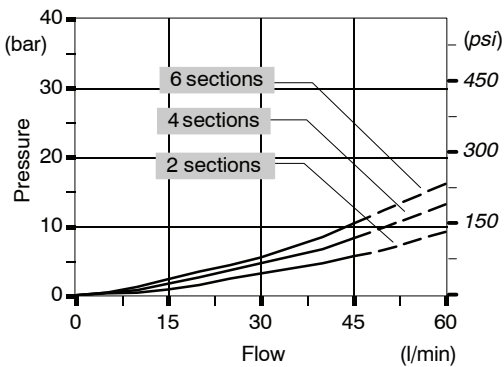

Pressure drop P→A(B)

on 6 sections directional valve

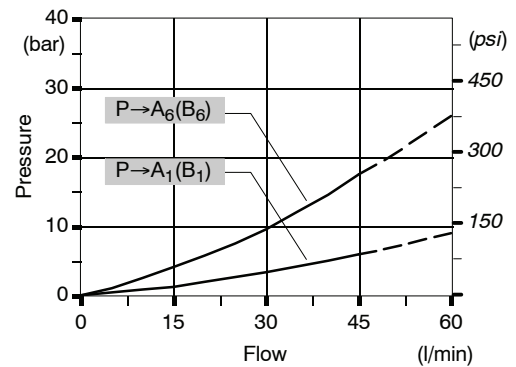

Pressure drop A(B)→T

on 6 sections directional valve

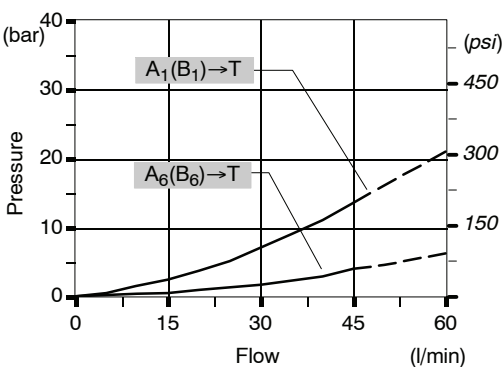



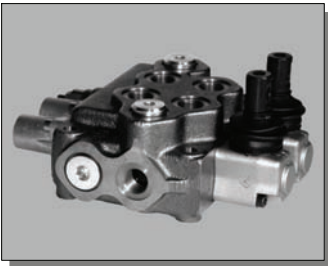

### Directional valve with parallel circuit

Dimensional data .....	78
Hydraulic circuit .....	79
Ordering codes .....	80
Inlet relief options .....	12
Spools .....	82
“A” side spool positioners .....	86
“B” side options .....	39
Complete controls .....	44
Outlet port options .....	97
Service and auxiliary valves	
ordering codes .....	100
port relief valves .....	102
flange mounted relief valves .....	103
fixed setting antishock and anticavitation valves . . . .	104
adjustable setting antishock and anticavitation valves	106
flow control valves .....	110
<b>Other executions</b>	
Main features .....	113
Directional valve SD5/1-N .....	114
Directional valve SD5/1-D .....	115
Directional valve SD5-S with series circuit .....	116
Directional valve SD5-SP with tandem circuit .....	118
Directional valve SDM105 with flow control .....	120

## Dimensional data (parallel circuit)

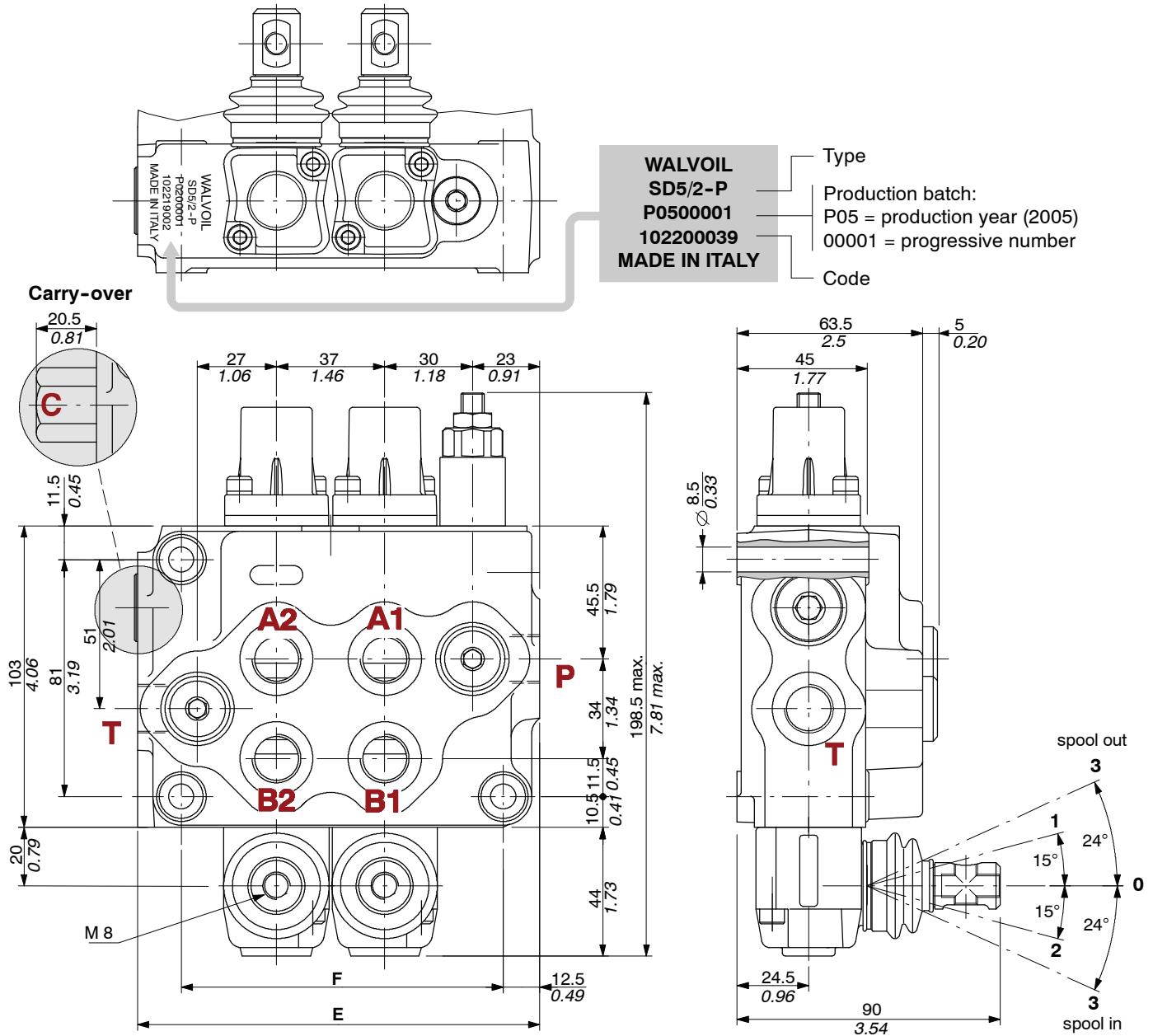

TYPE	E		F		Weight	
	mm	in	mm	in	kg	lb
SD5/1-P	100.5	3.96	73	2.87	3.5	7.7
SD5/2-P	137.5	5.41	110	4.33	5.2	11.5
SD5/3-P	174.5	6.87	147	5.79	6.9	15.2
SD5/4-P	211.5	8.33	184	7.24	8.1	17.9

TYPE	E		F		Weight	
	mm	in	mm	in	kg	lb
SD5/5-P	248.5	9.78	221	8.70	10.1	22.3
SD5/6-P	285.5	11.24	258	10.16	11.7	25.8
SD5/7-P	322.5	12.70	295	11.61	13.2	29.1

**Parallel**

Standard configuration with side inlet and outlet and open centre (AET execution).

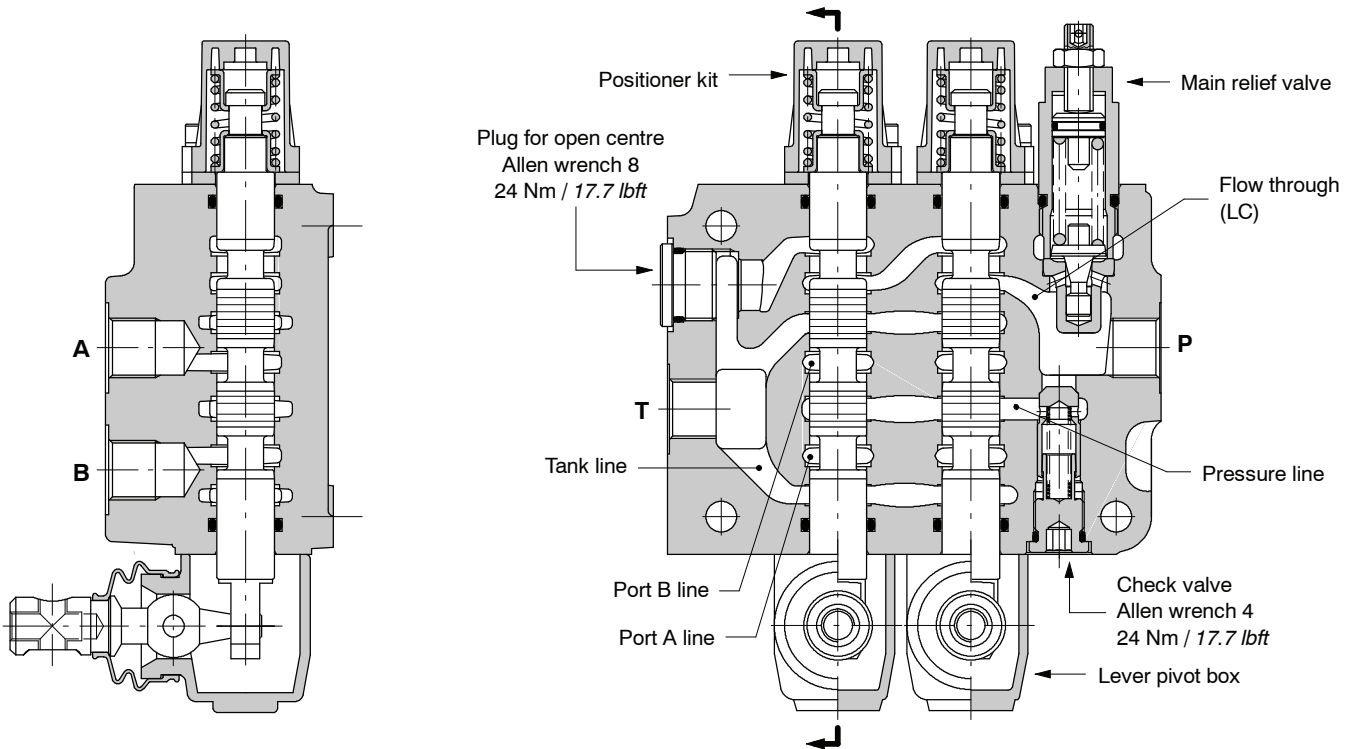

**Standard configuration**

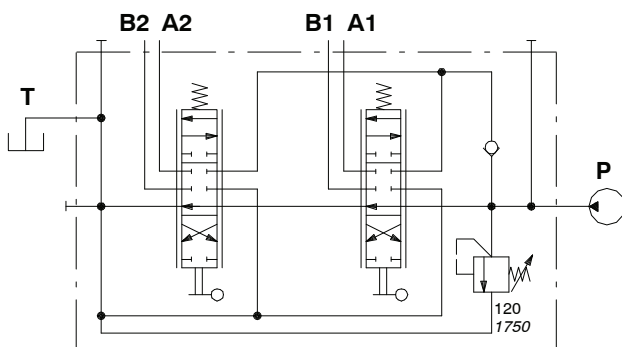

Description example:

SD5/2-P(JG3-120)/ED-18L/ED-18L/AET

**Configuration with upper inlet and outlet**

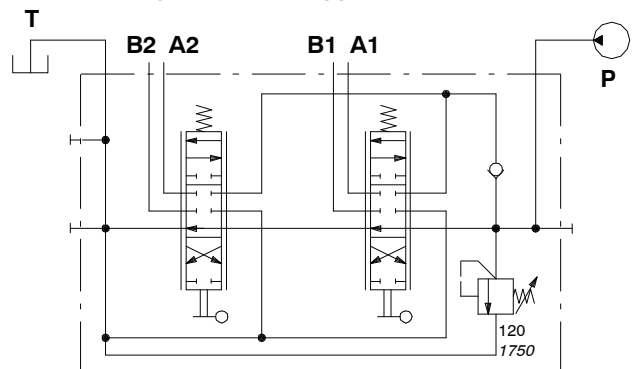

Description example:

SD5/2-P(JG3-120)/ED-18L/ED-18L/AET-PSA

## Ordering codes

### Description example:

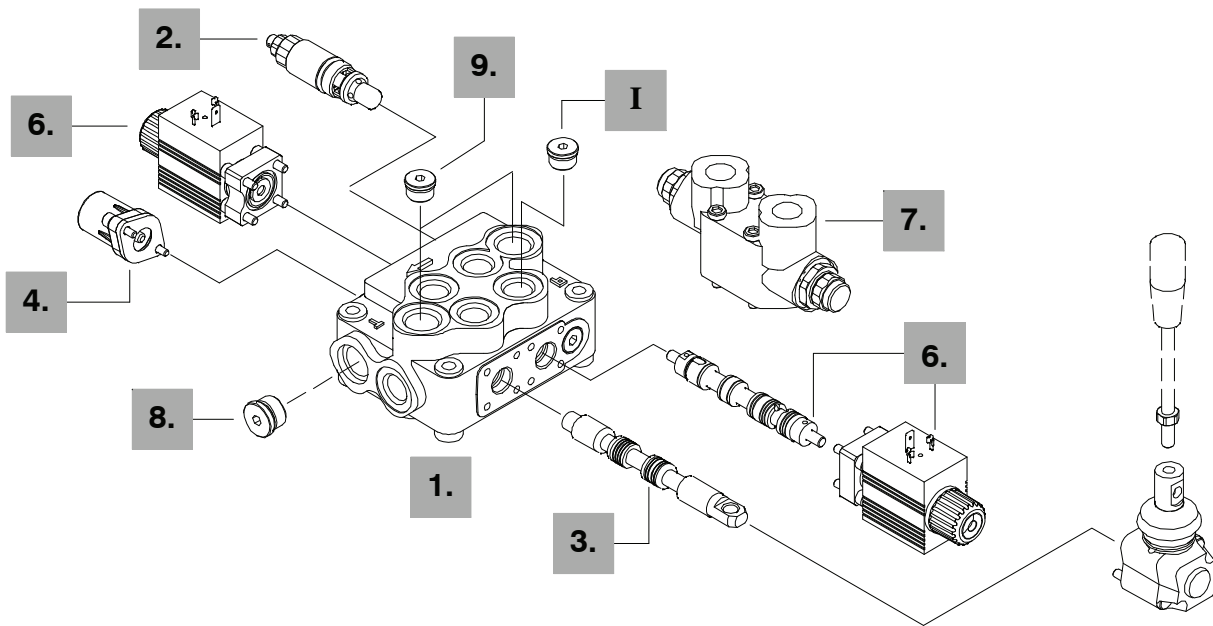
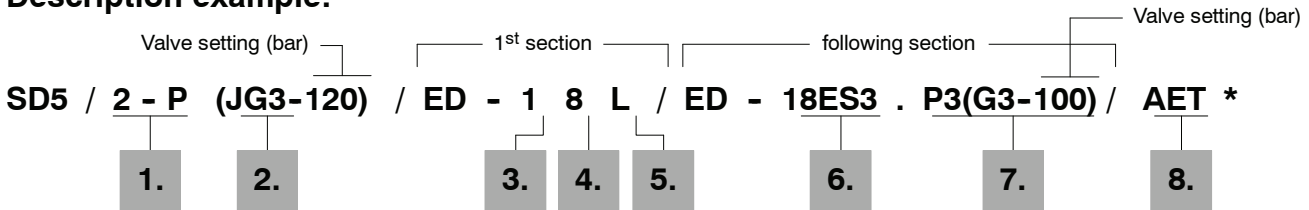

### 1. Body kit \*

TYPE	CODE	DESCRIPTION
1-P	5KC1193000	Parallel, 1 section
2-P	5KC1223000	Parallel, 2 sections
3-P	5KC1243000	Parallel, 3 sections
4-P	5KC1273000	Parallel, 4 sections
5-P	5KC1313000	Parallel, 5 sections
6-P	5KC1353000	Parallel, 6 sections
7-P	5KC13E3000	Parallel, 7 sections

Include body, seals and load check valve.

### 2. Inlet relief options

page 12

TYPE	CODE	DESCRIPTION
------	------	-------------

VMD5 direct pressure relief valve type J

Standard setting is referred to 10 l/min flow.

(JG2-63)	5KIT105412	Range 40 to 63 bar / 580 to 900 psi standard setting 63 bar / 900 psi
(JG3-120)	5KIT105413	Range 50 to 200 bar / 725 to 2900 psi standard setting 120 bar / 1750 psi
(JG4-220)	5KIT105414	Range 160 to 315 bar / 2300 to 4600 psi standard setting 220 bar / 3200 psi
SV	XTAP623282	Relief valve blanking plug

### 3. Spool options

page 82

TIPO	CODICE	DESCRIZIONE
ED-1	3CU1210730	Double acting, 3 positions, with A and B closed in neutral position
ED-1B	3CU1222700	Double acting, 3 positions, with B open to tank in neutral position
ED-2	3CU1225730	Double acting, 3 positions, with A and B open to tank in neutral position
ED-2H	3CU1225790	Double acting, 3 positions, with A e B partially open to tank in neutral position
ED-4	3CU1235700	Single acting on B, 3 positions, A plugged requires G3/8 plug (see part I)

Special spools for particular positioner kits ..... page 84

ED-5PY	3CU1245700	Double acting, 4 positions, floating circuit in 4 <sup>th</sup> position with spool out, with check valve
--------	------------	---

Special spools for standard positioner kits ..... page 85

ED-8F	3CU1261700	Double acting, 3 positions, regenerative circuit in 2 <sup>nd</sup> position with spool out
-------	------------	---

NOTE (\*) - Codes are referred to **BSP** threads.



**4. "A" side spool positioners page 86**

TYPE	CODE	DESCRIPTION
<b>8</b>	5V08104000	With spring return in neutral position
<b>8D</b>	5V08104200	With spring return in neutral position and pin with M6 female thread for dual control
<b>8D2</b>	5V08104220	With spring return in neutral position and pin with M8 male thread for dual control
<b>8F2</b>	5V08104101	With spring return in neutral position and adjustable flow limiter
<b>19</b>	5V19104000	2 positions, with spring return in neutral position from position 1
<b>20</b>	5V19104000	2 positions, with spring return in neutral position from position 2
<b>9</b>	5V09104010	With detent in position 1 and spring return in neutral position
<b>10</b>	5V10104011	With detent in position 2 and spring return in neutral position
<b>11</b>	5V11104000	Detent in positions neutral, 1 and 2
<b>12</b>	5V12104000	Detent in positions 1 and 2
<b>15</b>	5V15104000	2 positions, detent in positions 1 and neutral
<b>16</b>	5V16104000	2 positions, detent in positions 2 and neutral
<b>9BZ</b>	5V09204010	With detent in position 1 and spring return in neutral position
<b>10BZ</b>	5V10204010	With detent in position 2 and spring return in neutral position
<b>11BZ</b>	5V11204010	Detent in positions 1 and 2 and spring return in neutral position
<b>8MG3</b>	5V08104660	With spring return in neutral position and microswitch in positions 1 and 2
<b>8P</b>	5V08104701	ON/OFF pneumatic kit
<b>8EP3</b>	5V08104735	ON/OFF 12 VDC electro-pneumatic kit
	5V08104740	ON/OFF 24 VDC electro-pneumatic kit
<b>8ED3</b>	5V08104350	ON/OFF 12 VDC electro-hydraulic kit
	5V08104351	ON/OFF 24 VDC electro-hydraulic kit
<u>Particular positioner kits for special spools . . . . . page 96</u>		
<b>13QN</b>	5V13404020	4 pos. with spring return in neutral pos. and detent in 4 <sup>th</sup> pos.: <b>for spool 5PY</b>

**I "A" and "B" ports plugs \***

TYPE	CODE	DESCRIPTION
<b>G3/8</b>	3XTAP722160	for single acting spool type 3

**5. "B" side options page 39**

TYPE	CODE	DESCRIPTION
<b>L</b>	5LEV105000	Standard lever box
<b>LM10</b>	5LEV205000	Lever box for M10 handlever
<b>LF1</b>	5LEV105102	Lever box with adjustable flow limiter
<b>LEB</b>	5LEV605000	Safety lever box, vertical configuration
<b>LUP</b>	5LEV805005	Safety lever box, horizontal configuration
<b>SLP</b>	5COP105000	Witout lever box, with dust-proof plate
<b>SLC</b>	5COP205000	Witout lever box, with endcap
<b>TQ</b>	5TEL105110	Flexible cable connection
<b>LCB</b>	5CLO205100	Joystick lever for 2 sections operation

**6. Complete controls page 44**

Proportional hydraulic control type **8IM** and ON/OFF solenoid control type **8ES**.

**7. Aux. and service valves page 100**

Port relief, anti-shock, pilot operated check and flow regulation valves.

**8. Outlet port options page 97**

TYPE	CODE	DESCRIPTION
<b>AET</b>	XTAP623170	Open centre plug
<b>AEK</b>	3XTAP522282	Closed centre plug
<b>AE</b>	3XGIU522460*	G3/8 carry-over sleeve
<b>AET-L</b>	XCAR405300	With hydraulic pilot unloader valve
<b>AET-LT</b>	XTAP523370	Unloader valve blanking plug

**Electric control unloader valve:** for valves and coils list see page 98.

**9. Inlet and outlet selection \* page 79**

TYPE	CODE	DESCRIPTION
<b>PSL</b>	3XTAP722160	Side ports; need n.2 G 3/8 plugs, standard configuration (omit in valve description)
<b>PSA</b>	3XTAP722160	Upper ports; need n.2 G 3/8 plugs

**II Optional handlevers**

TYPE	CODE	DESCRIPTION
<b>AL01/M8x120</b>	170011012	For lever L: height 120 mm / 4.72 in
<b>AL01/M10x150</b>	170012015	For lever LM10: height 150 mm / 5.91 in
<b>AL08/M12x150</b>	170013115	For joystick LCB: height 150 mm / 5.91 in

Spool options

Tipo ED-1

For special requirement, spool 1CEX code 3CU1210780 suggested for flow up to 15 l/min

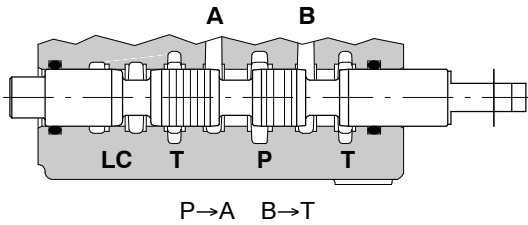

stroke:  
+ 5.5 mm / 0.22 in

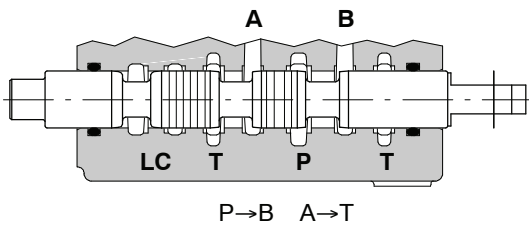
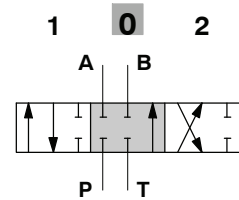
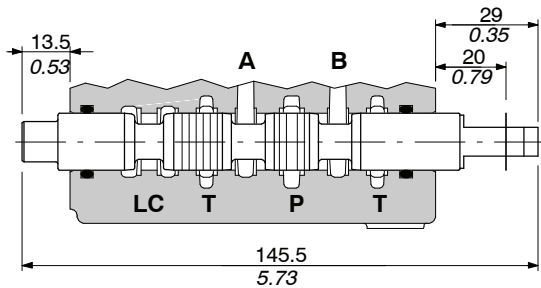
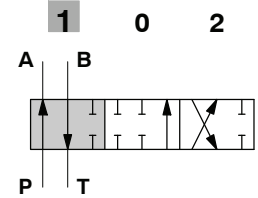

stroke:  
- 5.5 mm / 0.22 in

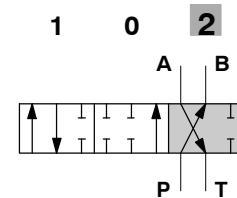

Performance data

Spool metering P→A(B)

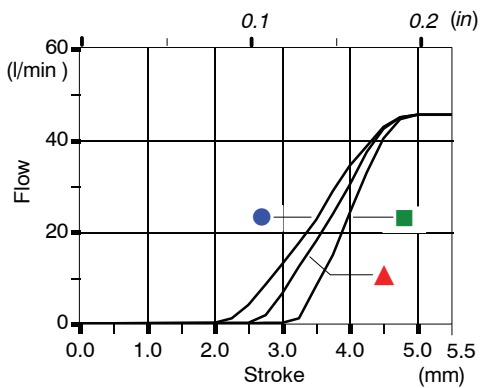

Q<sub>in</sub> = 45 l/min

- P<sub>(on ports)</sub> = 63bar / 900 psi
- ▲ P<sub>(on ports)</sub> = 100bar / 1450 psi
- P<sub>(on ports)</sub> = 250bar / 3600 psi

Spool metering A(B)→T

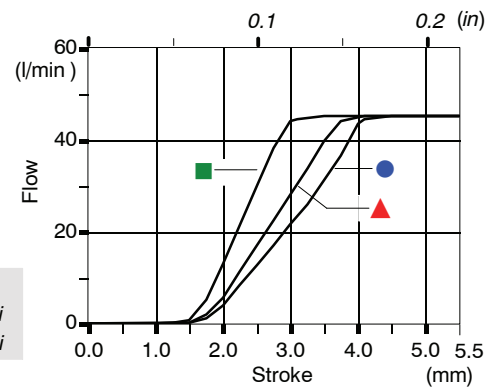

Type ED-1B

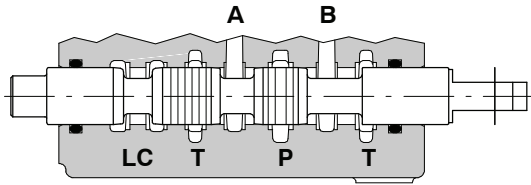

P-A closed, B→T, flow through line (LC) open

+ 5,5 mm / 0.22 in  
 (1) ▶  
 ◀▶ (0)  
 ◀ (2)  
 - 5,5 mm / 0.22 in

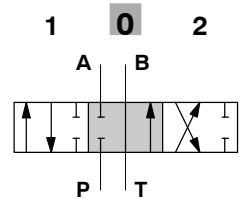

Type ED-2

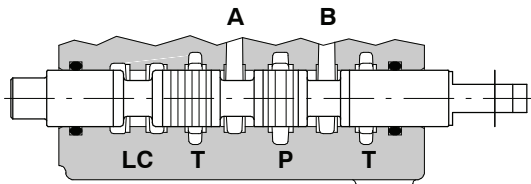

P closed, A-B→T, flow through line (LC) open

+ 5,5 mm / 0.22 in  
 (1) ▶  
 ◀▶ (0)  
 ◀ (2)  
 - 5,5 mm / 0.22 in

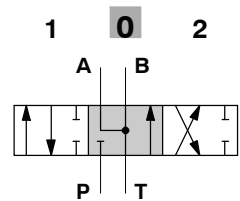

Type ED-2H

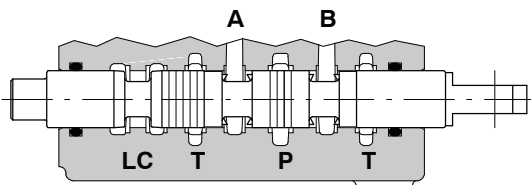

P closed, A-B partially open to tank,  
 flow through line (LC) open

+ 5,5 mm / 0.22 in  
 (1) ▶  
 ◀▶ (0)  
 ◀ (2)  
 - 5,5 mm / 0.22 in

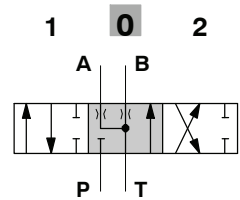

Type ED-4

Port A closed  
 Allen wrench 6  
 24 Nm / 17.7 lbf

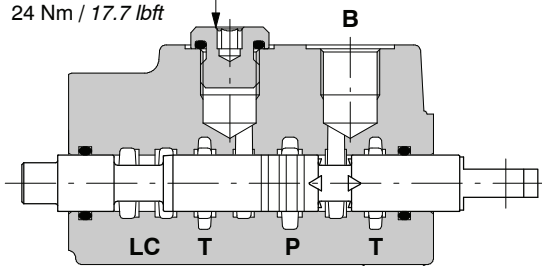

P-A-T closed, flow through line (LC) open

+ 5,5 mm / 0.22 in  
 (1) ▶  
 ◀▶ (0)  
 ◀ (2)  
 - 5,5 mm / 0.22 in

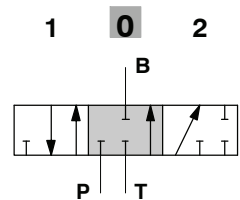

Spool options

Tipo ED-5PY

It needs special body with extra machining: for information please contact Sales Department.  
 This spool must be coupled with positioner type 13QN (see page 96).

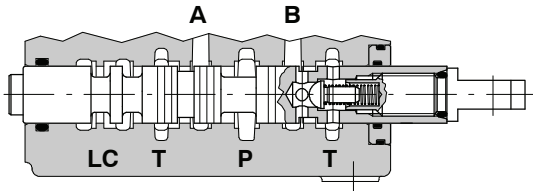

A-B→T (floating detent)

stroke:  
+ 9 mm / 0.35 in

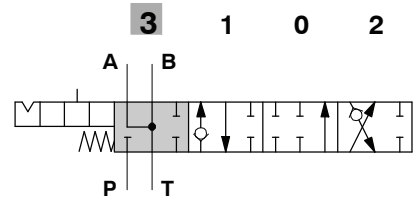

3 1 0 2

corsa + 9 mm

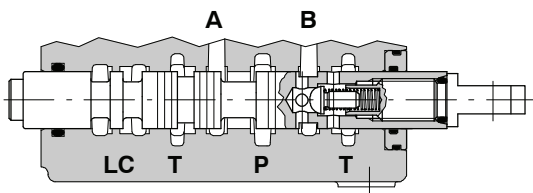

P→A , B→T

stroke:  
+ 4.5 mm / 0.18 in

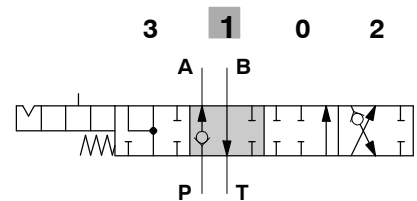

3 1 0 2

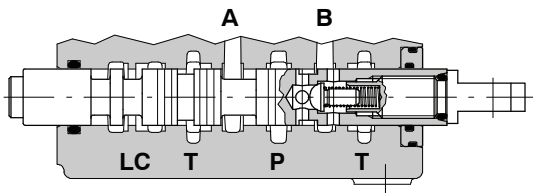

P-A-B-T closed,  
with flow through line (LC) open

stroke:

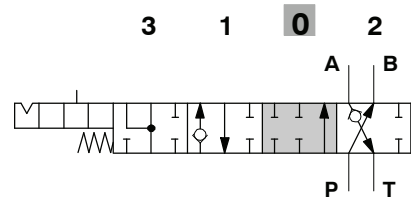

3 1 0 2

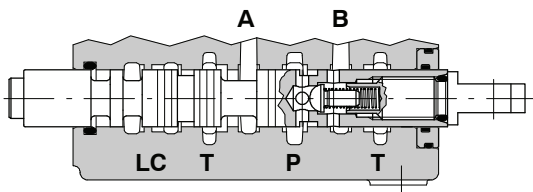

P→B , A→T

stroke:  
+ 4.5 mm / 0.18 in

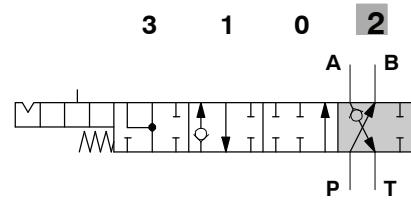

3 1 0 2

Performance data

Spool metering

Q<sub>in</sub> = 45 l/min / P<sub>(on ports)</sub> = 100 bar - 1450 psi  
 0.1 0.2 (in)

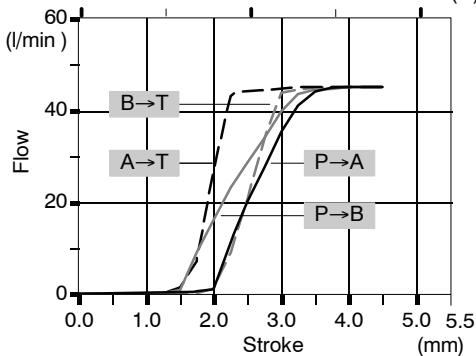

Pressure drop in position 3

(last section)

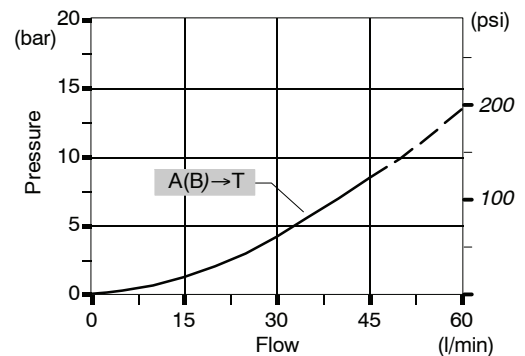

Type ED-8F

It needs special body with extra machining: for information please contact Sales Department.

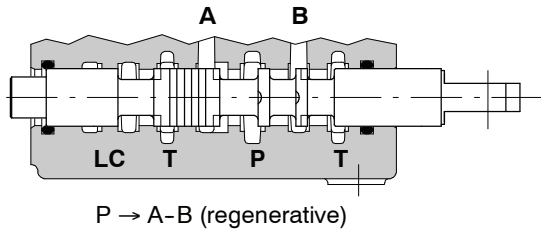

stroke:  
+ 5.5 mm / 0.22 in

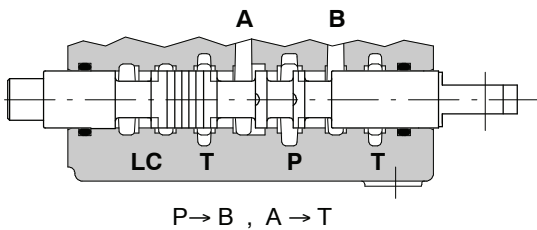
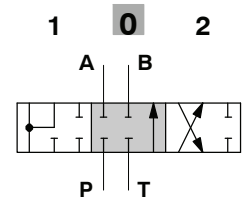
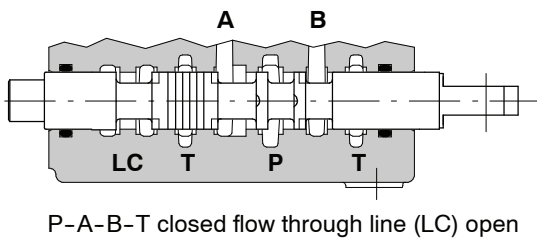
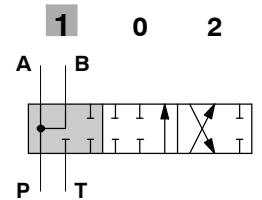

stroke:  
- 5.5 mm / 0.22 in

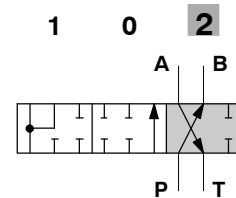

Performance data

Spool metering

$Q_{in} = 45 \text{ l/min} / P_{(on ports)} = 100 \text{ bar} - 1450 \text{ psi}$   
0.1 0.2 (in)

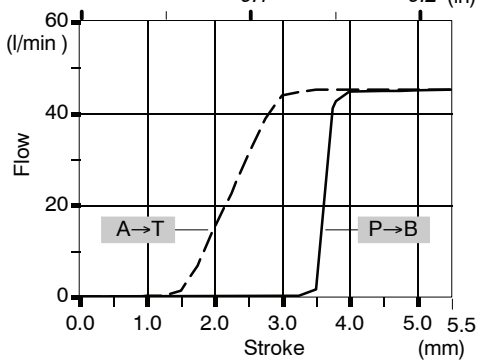

Pressure drop in position 1

(in first section)

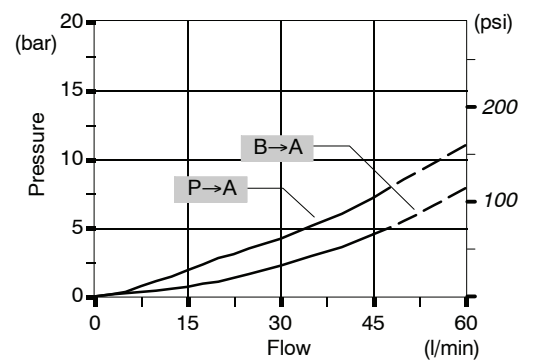

"A" side spool positioners

With spring return in neutral position

8 kit

It's supplied with standard spring type D (see force-stroke diagram) and available with lighter spring type C (8MC code: 5V08204000) or heavier type E (8ME code: 5V08404000).

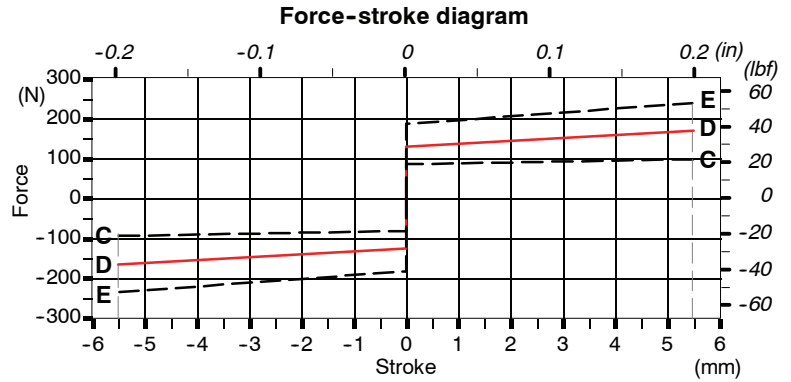
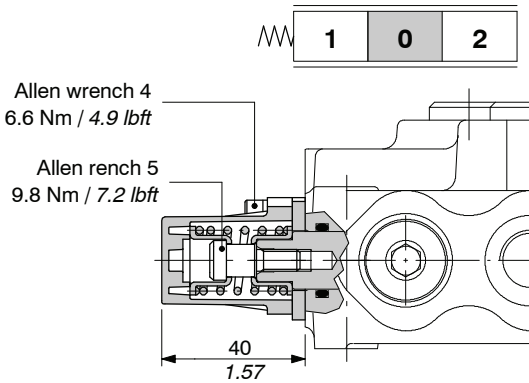

8D kit

Spool end joint code XPER315400, is available on request in order to screw onto pin.

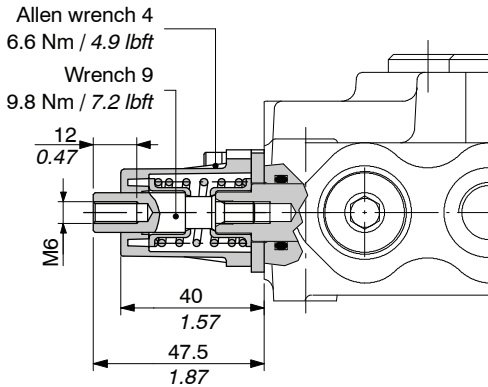

Spool end joint dimensions

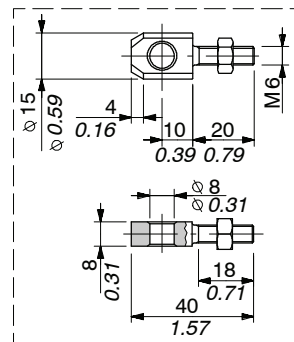

8D2 kit

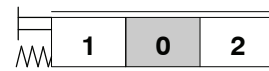
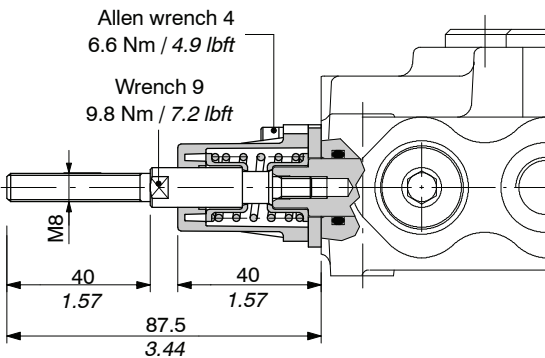

With spring return in neutral position

8F2 kit

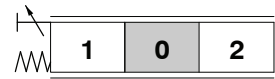
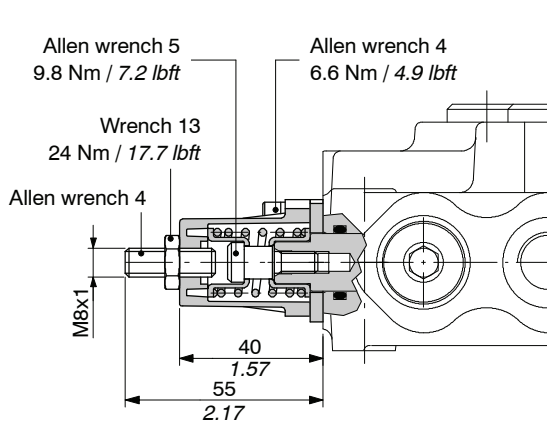

19 kit

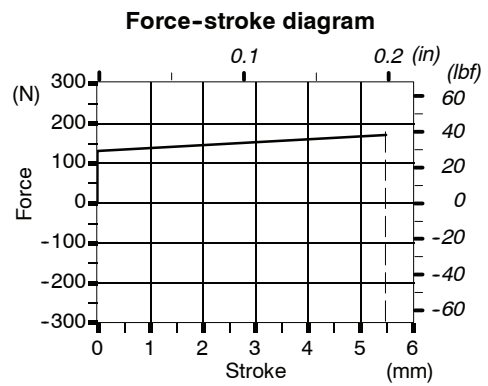
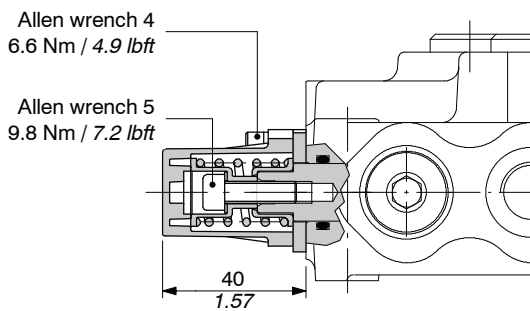
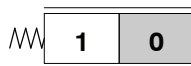

20 kit

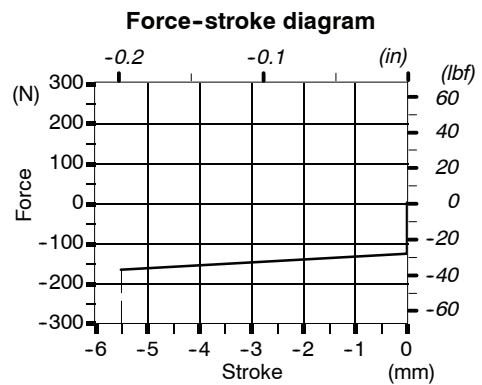
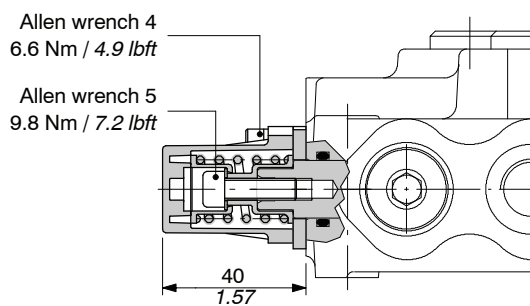
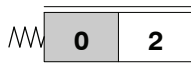

"A" side spool positioners

With detent

9 kit

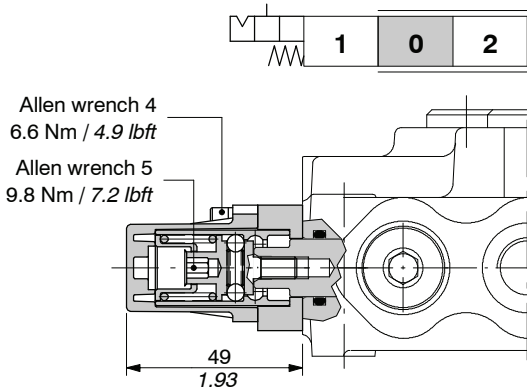

Operating features

Locking force (from pos. 0 to 1) . . . : 150 N / 33.7 lbf ±10%  
 Release force (from pos. 1 to 0) . . . : 140 N / 31.5 lbf ±10%

10 kit

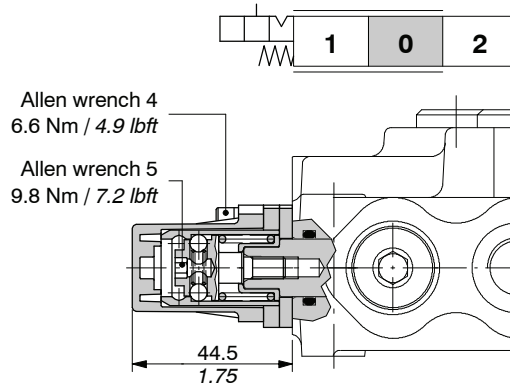

Operating features

Locking force (from pos. 0 to 2) . . . : 150 N / 33.7 lbf ±10%  
 Release (from pos. 2 to 0) . . . . . : 140 N / 31.5 lbf ±10%

11 kit

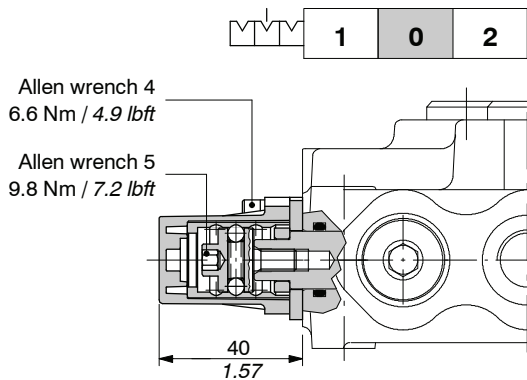

Operating features

Locking and release force . . . . . : 120 N / 27 lbf ±10%

12 kit

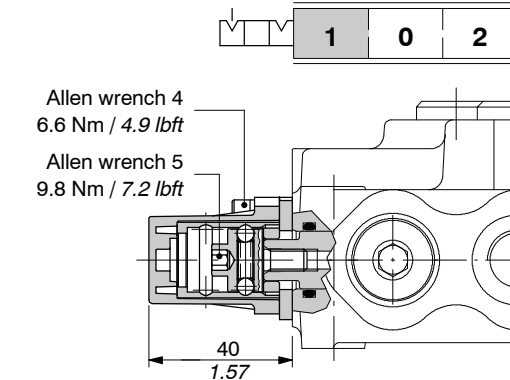

Operating features

Locking and release force . . . . . : 100 N / 22.5 lbf ±10%

15 kit

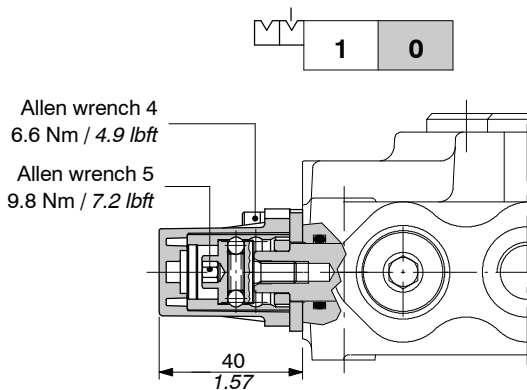

Operating features

Locking and release force . . . . . : 100 N / 22.5 lbf ±10%

16 kit

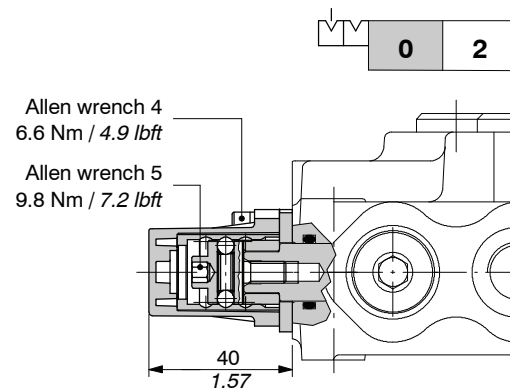

Operating features

Locking and release force . . . . . : 100 N / 22.5 lbf ±10%



With detent and spring return to neutral position from either directions

9BZ kit

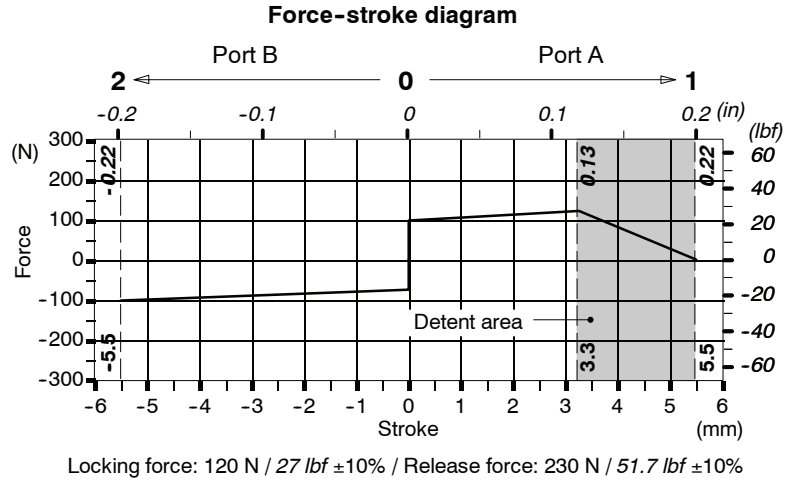
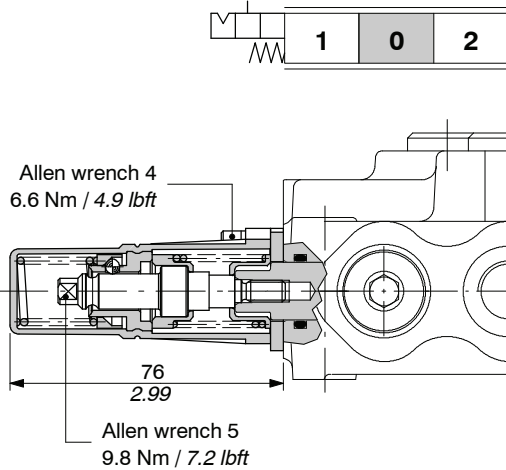

10BZ kit

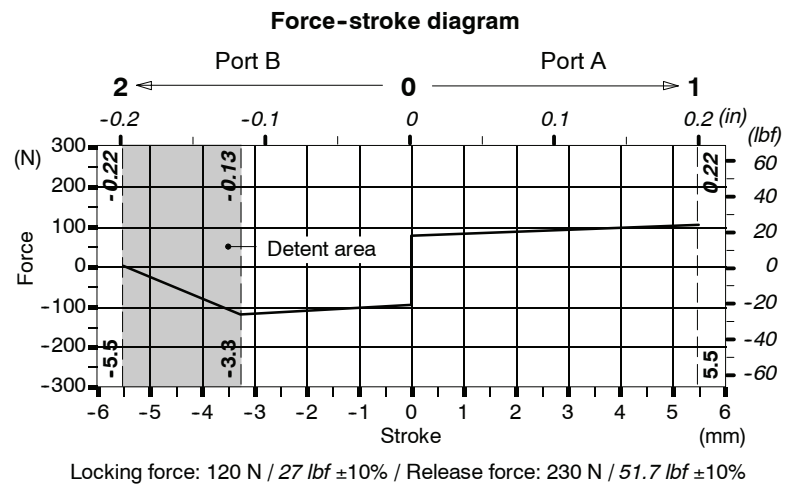
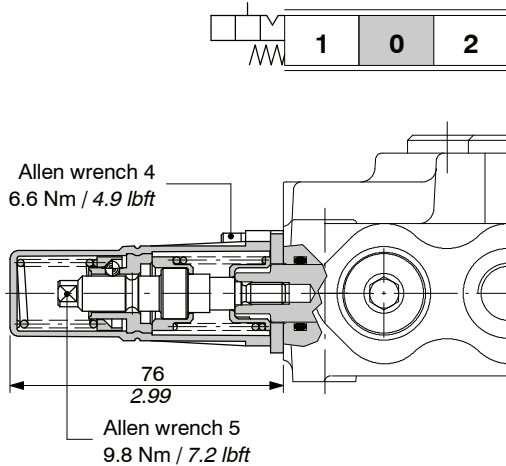

11BZ kit

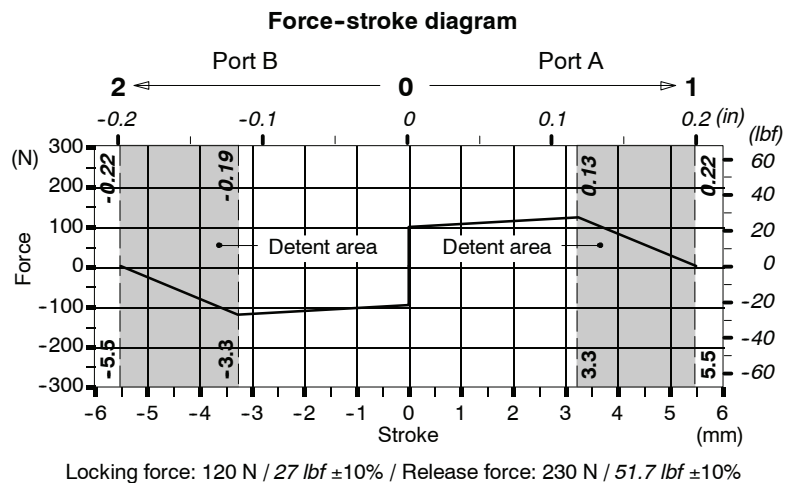
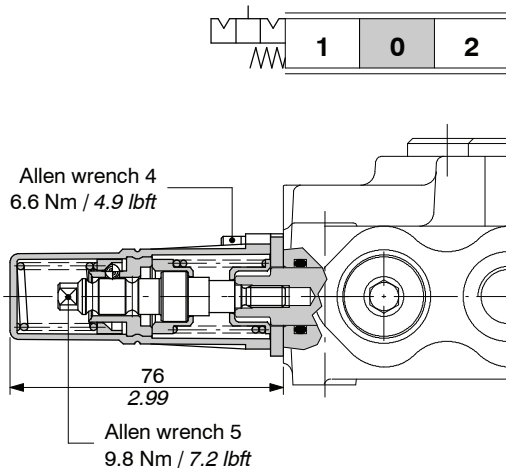

"A" side spool positioners

With microswitch type 8MG3(NO)

With spring return in neutral position and microswitch operated in both directions.

Also available **8MG1(NO)** configuration (microswitch operated in position 1) and **8MG2(NO)** configuration (microswitch operated in position 2); dimensions are the same of 8MG3 configuration.

Same configurations are available on request with normally closed (NC) contact.

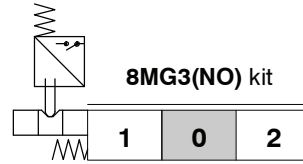
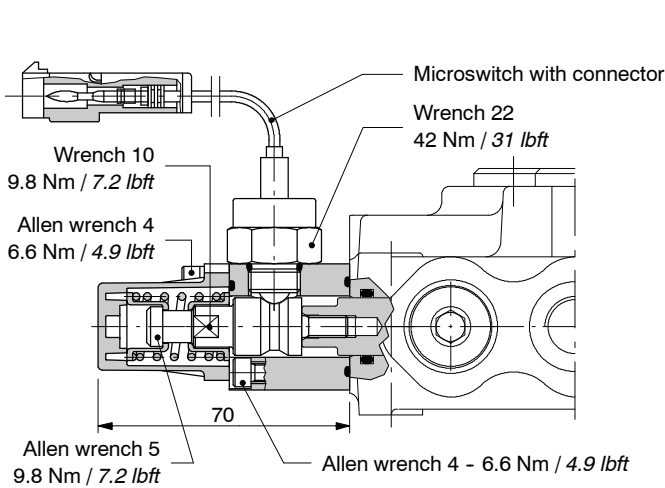

Other configurations

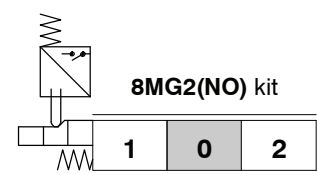
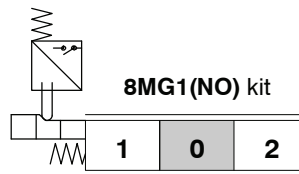

COMPLETE CONTROLS CODE

Contact	CONTROL TYPE			Need connector type
	8MG3	8MG2	8MG1	
NO	5V08104660	5V08104680	5V08104670	C07 see page 129

Operating features

MICROSWITCH

- Mechanical life : 5x10<sup>5</sup> operations
- Electrical life (resistive load) : 10<sup>5</sup> oper. - 7A / 13.5VDC
- : 5x10<sup>4</sup> oper - 10A / 12VDC
- : 5x10<sup>4</sup> per - 3A / 28VDC

More configurations and spare parts

It's possible to obtain further configurations of complete control, using the MG kit, microswitches and 3 positions "A" side spool positioner, as following draw.

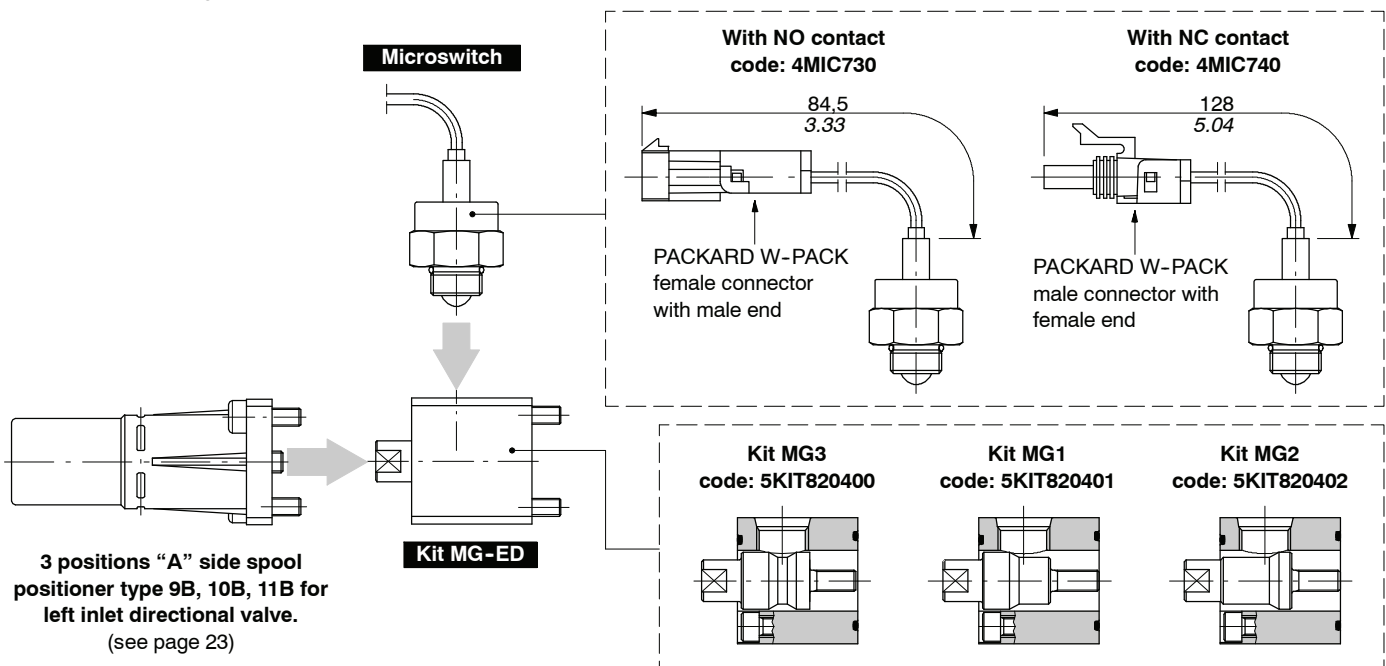

**"A" side spool positioners**

**Solenoid lock device**

It's possible to obtain further configurations of complete control, using the kit K-ED (for right inlet directional valve), coils and 3 positions "A" side spool positioner for left inlet directional valve, as following draw: for information contact Sales Department.

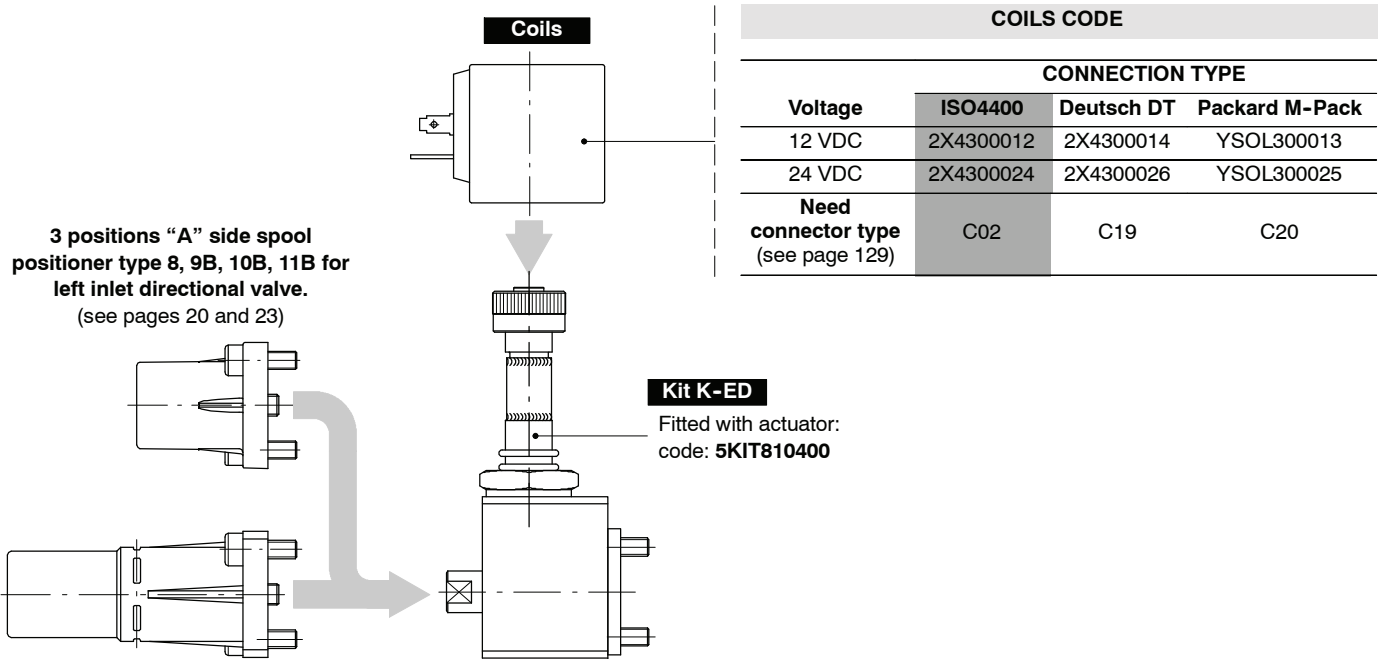

**Operating features**

ACTUATOR

Lock stroke ..... : 3.5 mm / 0.14 in

COIL

Depending on model: see following features

**Coil with ISO4400 connector**

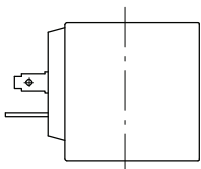

Nom. voltage tolerance .. : ±10%  
 Power rating ..... : 18 W  
 Nominal current ..... : 1.58 A - 12 VDC  
 ..... : 0.81 A - 24VDC  
 Coil insulance ..... : Class F  
 Weather protection ..... : IP65  
 Duty cycle ..... : 100%

**Coil with Deutsch DT connector**

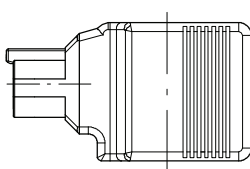

Nom. voltage tolerance .. : ±10%  
 Power rating ..... : 22 W  
 Nominal current ..... : 1.9 A - 12 VDC  
 ..... : 0.95 A - 24VDC  
 Coil insulance ..... : Class H  
 Weather protection ..... : IP65  
 Duty cycle ..... : 100%

**Coil with Packard M-Pack connector**

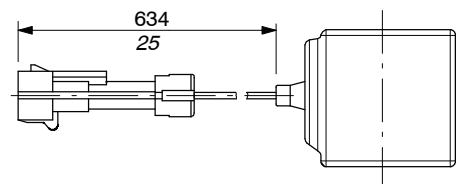

Nom. voltage tolerance .. : ±10%  
 Power rating ..... : 18 W  
 Nominal current ..... : 1.58 A - 12 VDC  
 ..... : 0.81 A - 24VDC  
 Coil insulance ..... : Class F  
 Weather protection ..... : IP65  
 Duty cycle ..... : 100%

“A” side spool positioners

ON/OFF electropneumatic kit type 8EP3

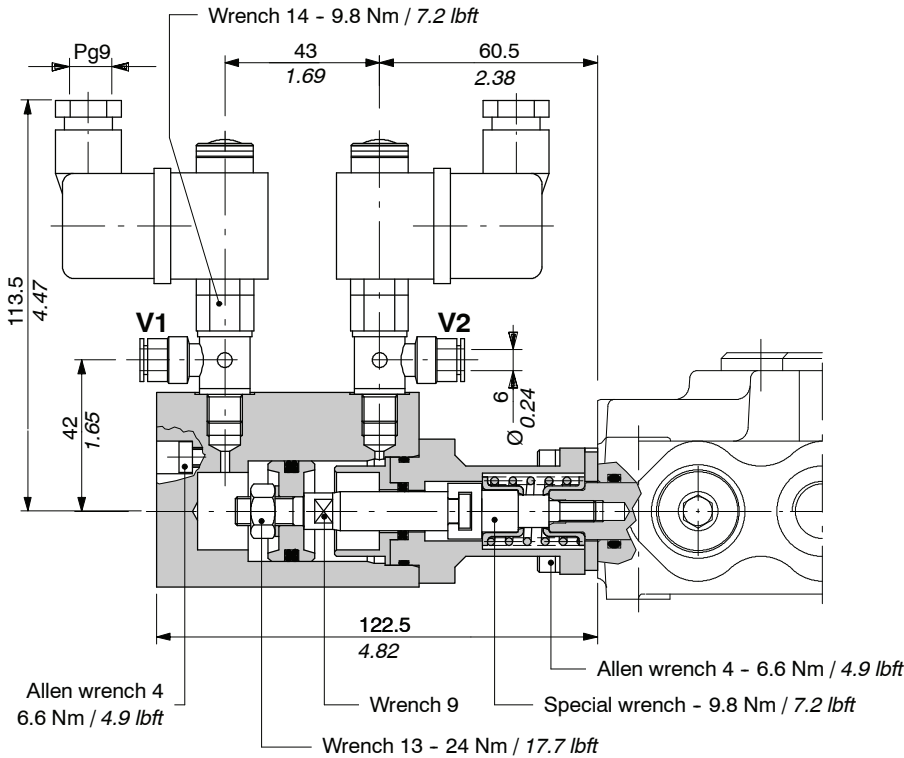

Scheme

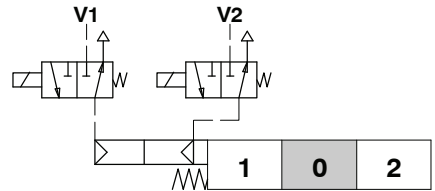

Scheme ISO 1219

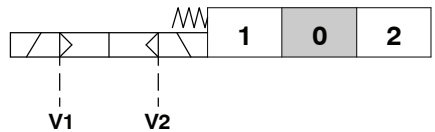

COMPLETE CONTROL CODES

Voltage	CONNECTION TYPE	
	ISO6952	Flying leads
	CONTROL TYPE	
	8EP3	8EP35
12 VDC	5V08104735	5V08104736
24 VDC	5V08104740	5V08104741
Need connector type (see page 129)	C01 (included)	/

COIL CODES

Voltage	CONNECTION TYPE	
	ISO6952	Flying leads*
12 VDC	2X4000013	2XB1000120000
24 VDC	2X4000025	2XB1000240000

\* Several type of connectors can be wired on request

Operating features

CONTROL

Pilot pressure : 6 bar / 87 psi  
: (max.10 bar / 145 psi)

COIL

Nominal voltage tolerance : ±10%  
Power rating : 8 W  
Nominal current : 0,67 A - 12 VDC  
: 0,33 A - 24VDC  
Coil insulation : Class F  
Weather protection : IP65  
Duty cycle : 100%

Coil with ISO6952 connector

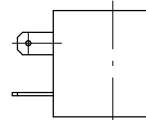

Coil with flying leads

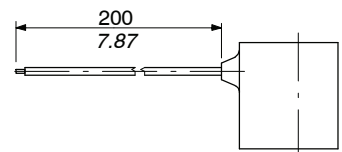

**ON/OFF pneumatic kit type 8P**

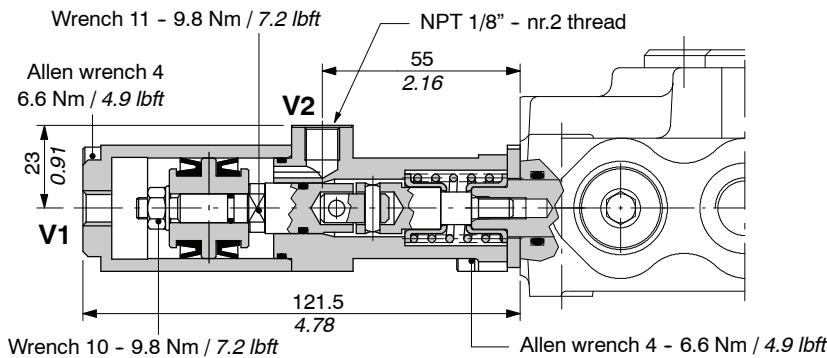

With spring return to neutral position.

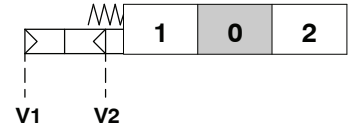

**Operating features**

Pilot pressure ..... : min. 5.5 bar / 80 psi  
 : max. 10 bar / 145 psi

**ON/OFF electrohydraulic kit type 8ED3**

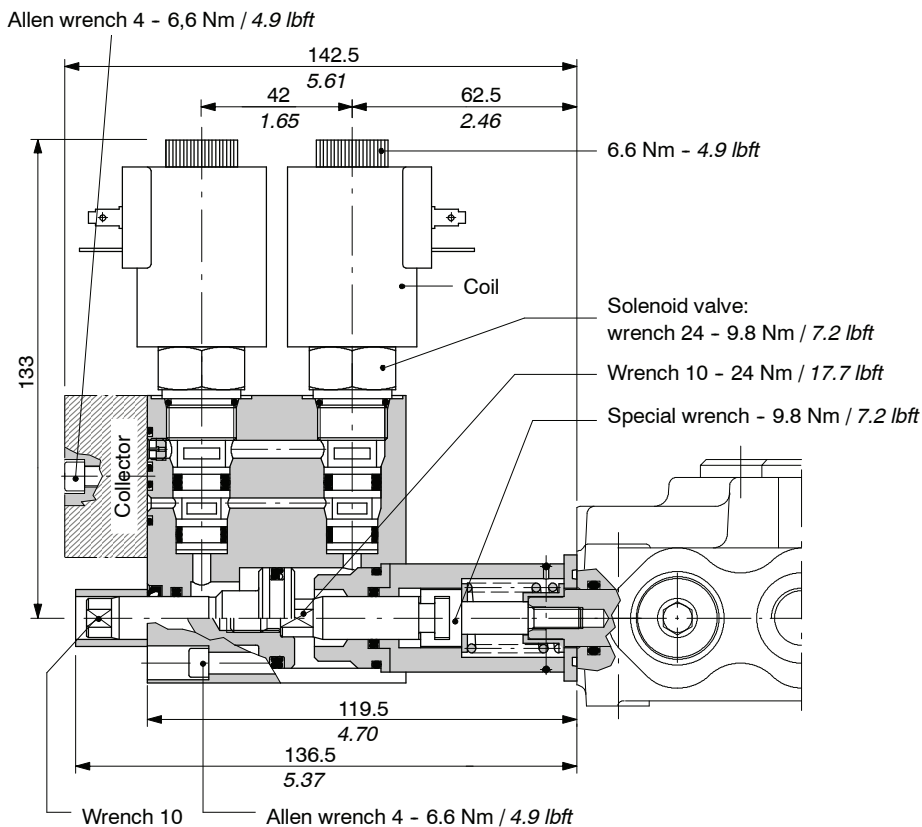

With external pilot and drain.

**Scheme**

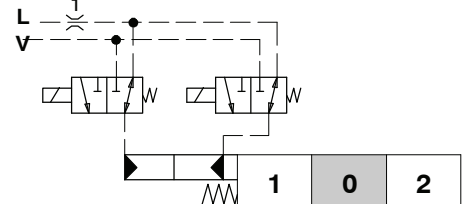

**Scheme ISO 1219**

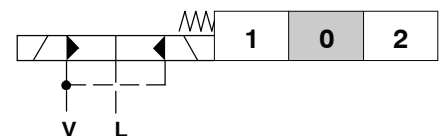

**COMPLETE CONTROL CODES**

	CONNECTION TYPE			
	ISO4400	AMP JPT		Deutsch DT
		without diodo	with diodo	
	CONTROL TYPE			
Voltage	8ED3	8ED32	8ED32D	8ED34
12 VDC	5V080104350	5V08104250	5V08104280	5V08104450
24 VDC	5V08104351	5V08104251	5V08104281	5V08104451
Need connector type (see page 129))	C02	C08	C08	C19

**Operating features**

**CONTROL**

Pilot pressure ..... : min. 10 bar / 145 psi  
 : max. 50 bar / 725 psi

Max backpressure on drain L . . : 25 bar / 360 psi

**COIL**

Nominal voltage tolerance . . . . : ±10%  
 Power rating . . . . . : 21 W  
 Nominal current . . . . . : 1.75 A - 12 VDC  
 : 0.87 A - 24VDC  
 Coil insulation . . . . . : Class F  
 Weather protection . . . . . : IP65  
 Duty cycle . . . . . : 100%

“A” side spool positioners

ON/OFF electrohydraulic kit type 8ED3

COIL CODES

Voltage	CONNECTION TYPE			
	ISO4400	AMP JPT		Deutsch DT
		without diodo	with diodo	
12 VDC	2XB1400121100	2XB1400121200	2XB1400121210	2XB1400120400
24 VDC	2XB1400241100	2XB1400241200	2XB1400241210	2XB1400240400

Coil with ISO4400 connection

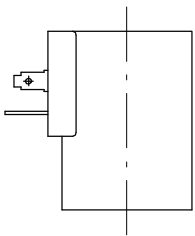

Coil with AMP JPT connection

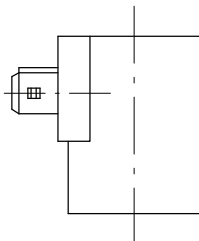

Coil with Deutsch DT connection

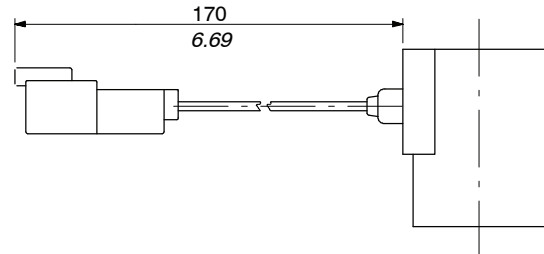

Collector kit for external pilot and drain

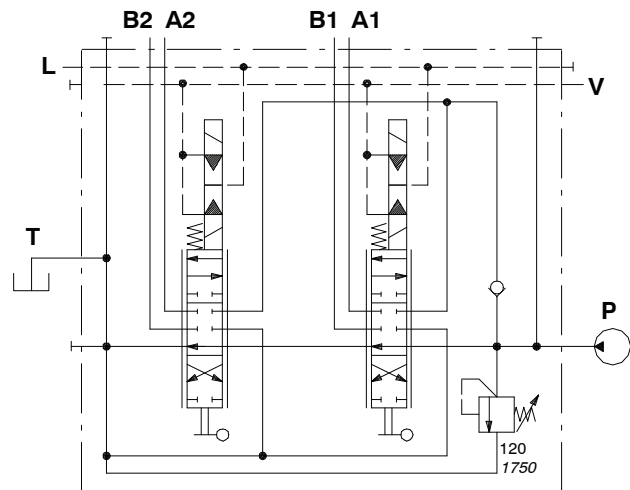
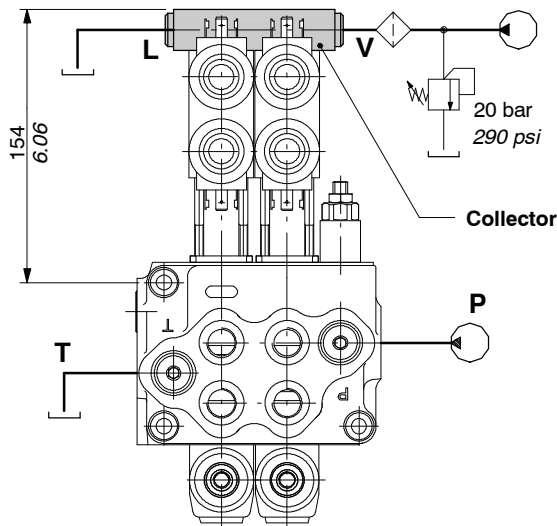

Description example:  
SD5/2-P(JG3-120)/ED-18ED3L/ED-18ED3L/AET-KE2S0-24VDC

COLLECTOR KIT CODES

Type	Code *	Description
KE1S0	5KE1S00030	Kit one section
KE2S0	5KE2S00230	Kit for 2 sections
KE3S0	5KE3S00230	Kit for 3 sections
KE4S0	5KE4S00230	Kit for 4 sections
KE5S0	5KE5S00230	Kit for 5 sections
KE6S0	5KE6S00230	Kit for 6 sections

(\*) codes are referred to BSP thread

**ON/OFF electrohydraulic kit type 8ED3**

**Collector kit with pilot and drain lines**

The kit is made of collector, VRP pressure reducing valve and pipes.

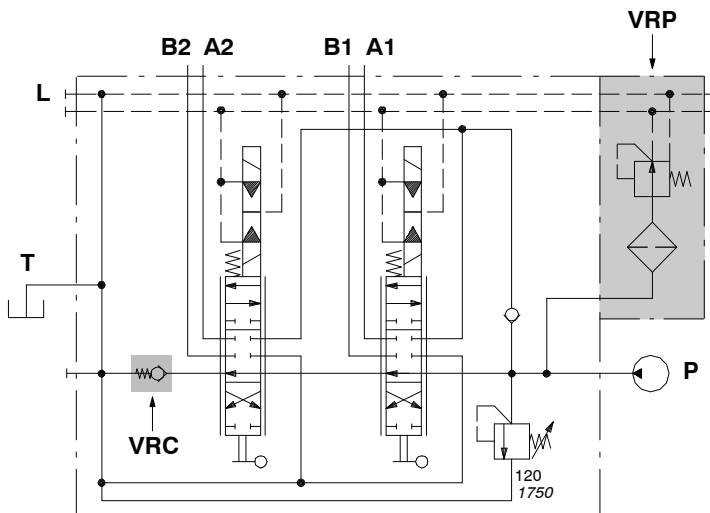
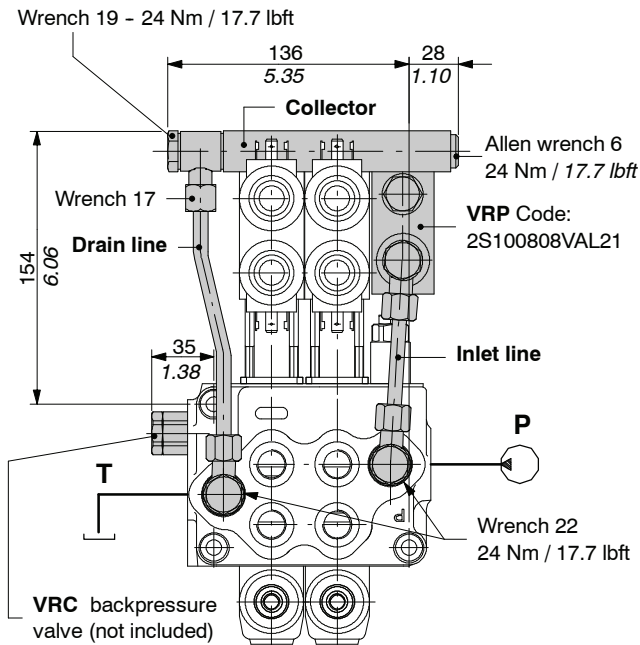

Description example:

SD5/2-P(JG3-120)/ED-18ED3L/ED-18ED3L/  
VRC-KE2R3-24VDC

**Operating features**

VRP VALVE

Output pressure ..... : 20 bar / 290 psi

Max flow ..... : 8 l/min

Filtering ..... : 80 μ

**COLLECTOR KIT CODES**

Typo	Code *	Description
KE1R0	5KE1R30230	Kit one section
KE2R0	5KE2R30230	Kit for 2 sections
KE3R0	5KE3R30230	Kit for 3 sections
KE4R0	5KE4R30230	Kit for 4 sections
KE5R0	5KE5R30230	Kit for 5 sections
KE6R0	5KE6R30230	Kit for 6 sections

(\*) Codes are referred to BSP thread

**VRC valve: code X003600010**

Valve assembled on flow through passage provides pilot pressure to the actuator.

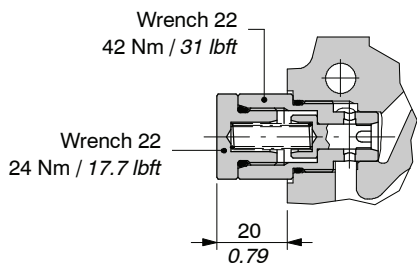

**Pressure drop P→T**

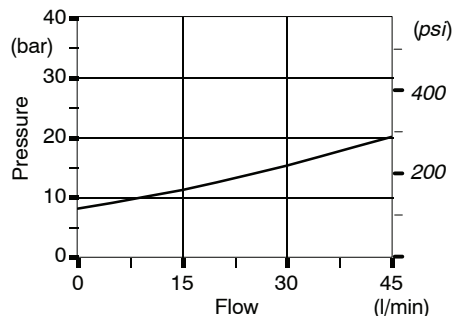

“A” side spool positioners

Particular positioner kits for special spools

13QN kit

Detent in 4<sup>th</sup> position with spool out: available only for spool type ED-5PY (see page 84).

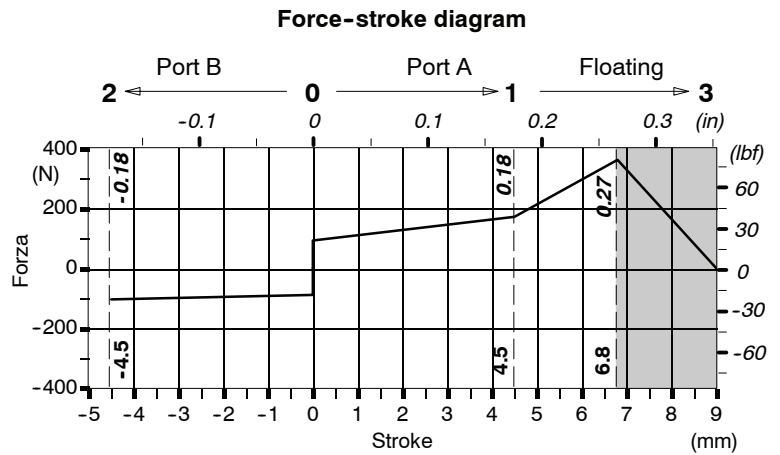
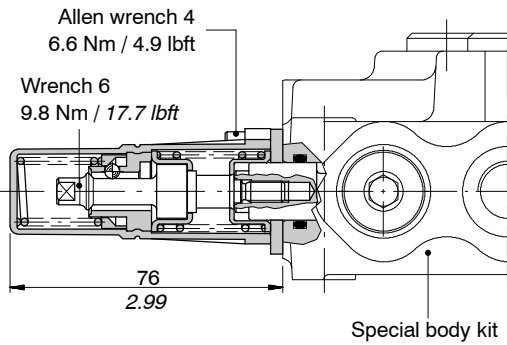
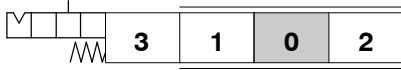

**Detent area**  
 Locking force: 360 N / 81 lbf ±10%  
 Release force: 390 N / 87.7 lbf ±10%



It's possible to have open centre, closed centre and carry-over.

Unloader valves are available: these valves need special bodies with appropriate cavity on lateral outlet port, the tank connection T must be on top.

**AET: open centre (standard)**

See page 79.

**AE:with carry-over**

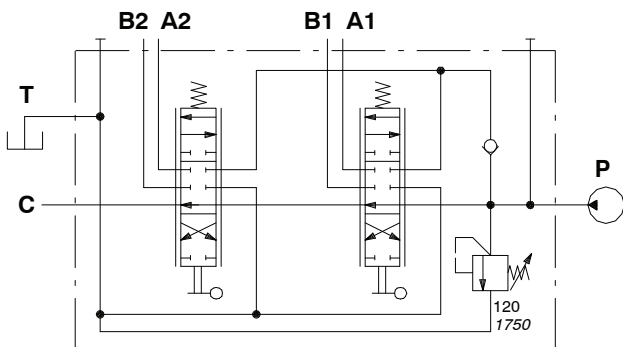
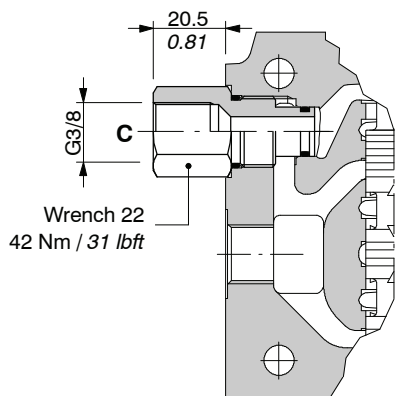

Description example:  
SD5/2-P(KG3-120)/ED-18L/ED-18L/AE

**AEK: closed centre**

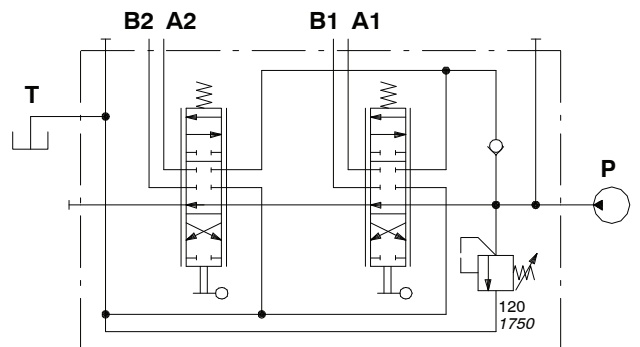
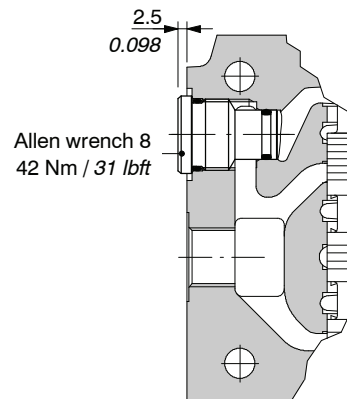

Description example:  
SD5/2-P(KG3-120)/ED-18L/ED-18L/AEK

**With hydraulic pilot unloader valve type L**

For safety reasons it's provided with pilot port plugged.

Wrench 24 - 42 Nm / 31 lbf

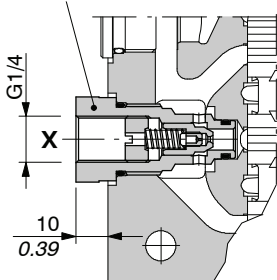

Pressure drop curve

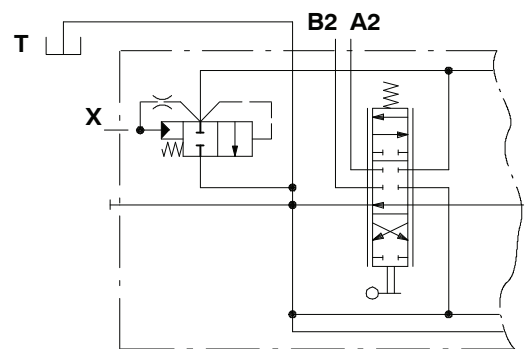
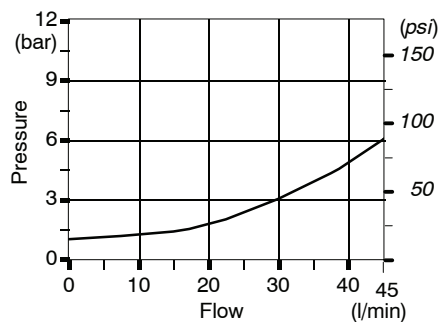

Description example:  
SD5/2-P(JG3-120)/ED-18L/ED-18L/AET-L

**Operating features**

Internal leakage ..... : 10 cm<sup>3</sup>/min a 100 bar  
: 0.61 in<sup>3</sup>/min at 1450 psi

Outlet port options

With solenoid pilot unloader valve

For the complete valve must be ordered the cartridge and the coil both; to follow please see code list and description composition.

Example of directional valve with normally open unloader valve

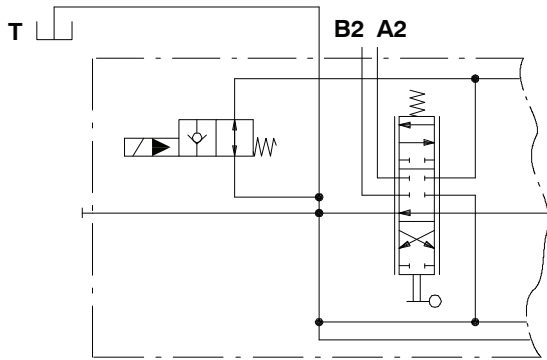

Description example:  
SD5/2-P(JG3-120)/ED-18L/ED-18L/AET-ELNW-12VDC

Example of directional valve with normally closed unloader valve

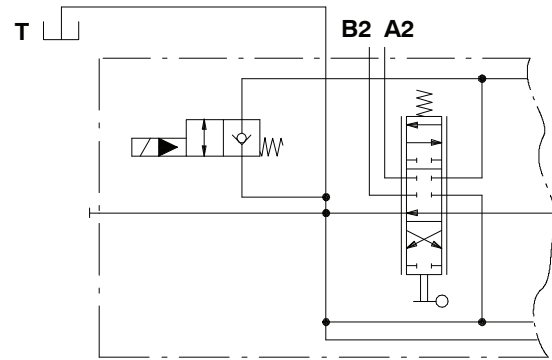

Description example:  
SD5/2-P(JG3-120)/ED-18L/ED-18L/AET-ELNW(NC)-12VDC

Description example:

SD5 / 2 - P (JG3-120) / ED-18L / ED-18L / AET-ELNW 4 (NC) - 12VDC

1.
2.
1.
2.

1. Solenoid pilot unloader valve

TYPE	CODE	DESCRIPTION
AET-ELNW	0EFW0132002	Normally open, without emergency
AET-ELNW(NC)	0EFW0132003	As previous, normally closed
AET-ELTW	0EFW0132000	Normally open, with "push&twist" emergency type
AET-ELPW	0EFW0132001	Normally open, with push-button emergency type

2. Coil

TYPE	CODE	DESCRIPTION
<u>With ISO4400 connection</u>		
12VDC	4SLE001200	Nominal voltage 12VDC
DB-12VDC	4SLE001217	As previous, with bi-directional diode
24VDC	4SLE002400	Nominal voltage 24VDC
DB-24VDC	4SLE002408	As previous, with bi-directional diode
<u>With AMP JPT connection</u>		
2-12VDC	4SLE001203	Nominal voltage 12VDC
2DB-12VDC	4SLE001211	As previous, with bi-directional diode
2-24VDC	4SLE002403	Nominal voltage 24VDC
<u>With Deutsch DT connection</u>		
4-12VDC	4SLE001202	Nominal voltage 12VDC, parallel connection
4DB-12VDC	4SLE001216	As previous, with bi-directional diode
4PD-12VDC	4SLE001201	Nominal voltage 12VDC, perpendicular connection
4PDDB-12VDC	4SLE001209	As previous, with bi-directional diode
4-24VDC	4SLE002402	Nominal voltage 24VDC, parallel connection
4PD-24VDC	4SLE002401	Nominal voltage 24VDC, perpendicular connection
4PDDB-24VDC	4SLE002407	As previous, with bi-directional diode

With solenoid pilot unloader valve

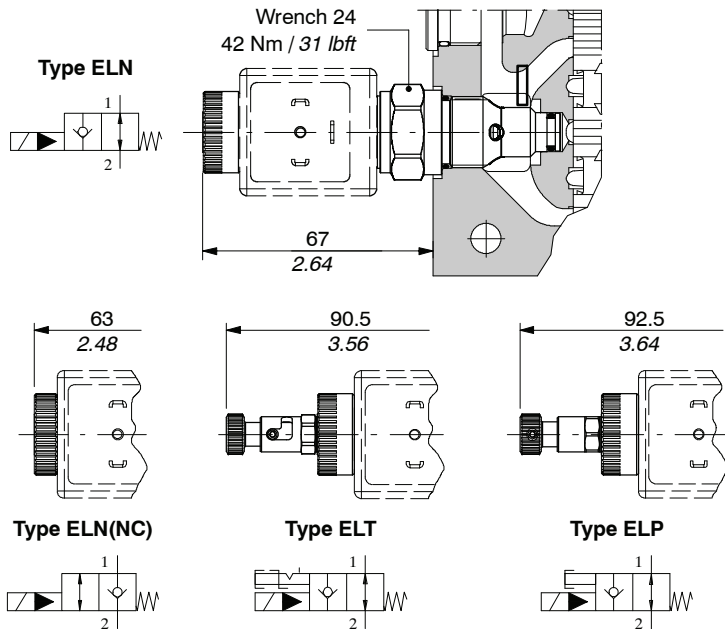

Valve operating features

- Max. flow ..... : 45 l/min
- Max. pressure ..... : 315 bar / 4600 psi
- Internal leakage (from 1 to 2) : max. 3 cm<sup>3</sup>/min at 100 bar  
: max . 4.6 in<sup>3</sup>/min at 1450 psi

Valve pressure drop from 1 to 2 in open position

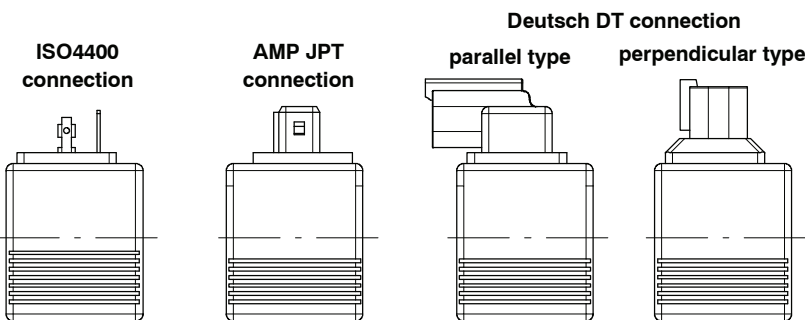
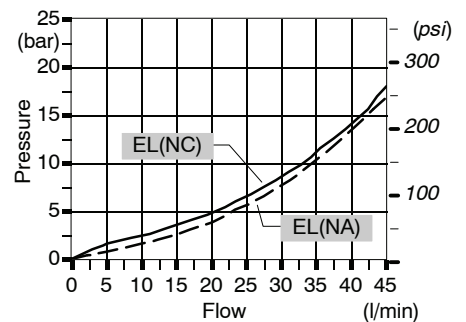

Coil operating features

- Nominal voltage tolerance. : ±10%
- Power rating ..... : 19.3 W - 12 VDC  
: 19.2 W - 24 VDC
- Max. operating current ... : 1.61 A - 12 VDC  
: 0.80 A - 24VDC
- Coil insulation ..... : Class H
- Weather protection ..... : IP65 - ISO4400  
: IP69K - Deutsch DT  
: IP65 - AMP JPT
- Insertion ..... : 100%

LT: unloader valve prearrangement

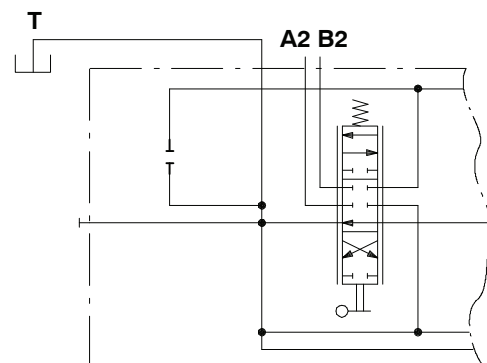
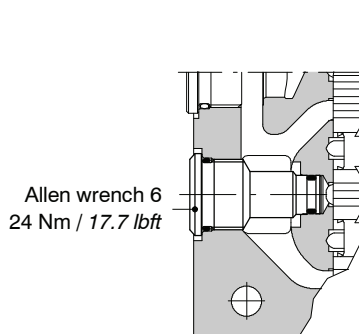

Description example>

SD5/2-P(JG3-120)/ED-18L/ED-18L/AET-LT

Service and auxiliary valves

All service and auxiliary valves need **special body**: contact Sales Department.

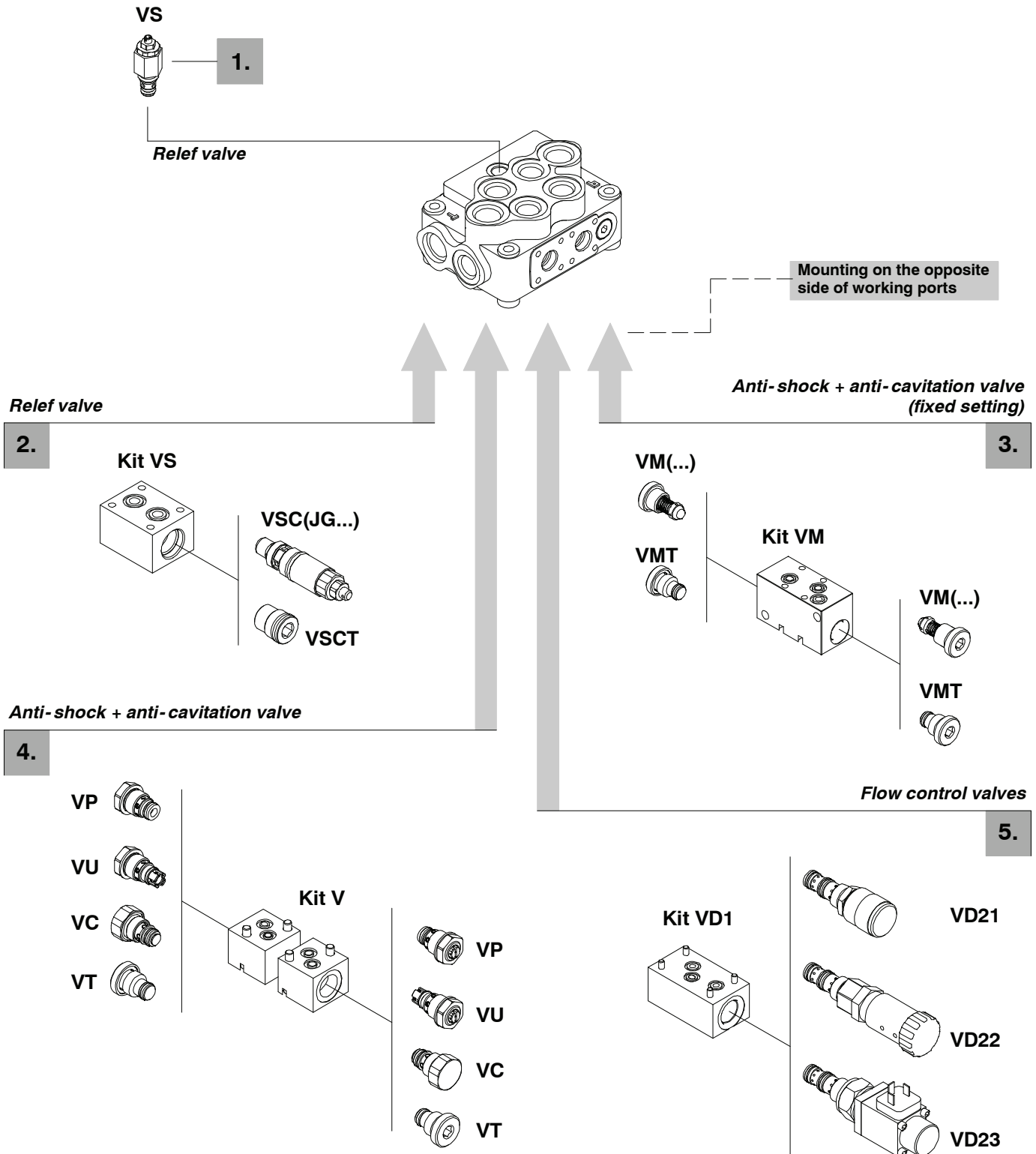

**1. Relief valves** *page 102*

TYPE	CODE	DESCRIPTION
<b>VS(G3-100)</b>	3XCAR505113	Range 40 to 200 bar / 580 to 2900 psi standard setting 100 bar / 1450 psi
<b>VST</b>	3XTAP419300	Valve blanking plug

**2. Flange mounted relief valve** *page 103*

TYPE	CODE	DESCRIPTION
<b>VSC(JG2-60)</b>	5KIT105412	Range 40 to 80 bar / 580 to 1150 psi standard setting 60 bar / 870 psi
<b>VSC(JG3-100)</b>	5KIT105413	Range 63 to 200 bar / 900 to 2900 psi standard setting 100 bar / 1450 psi
<b>VSC(JG4-200)</b>	5KIT105414	Range 160 to 250 bar / 2300 to 3600 psi standard setting 200 bar / 2900 psi
<b>VSCT</b>	XTAP623282	Valve blanking plug
<b>Kit VS</b>	5CO2420000	Mounting block kit

**3. VM anti-schock+anti-cavitation valve** *page 104*

Flange mounted type with **fixed setting** and fitted with mounting block.

TYPE	CODE	DESCRIPTION
<b>VM(50)</b>	5KIT326050	Setting 50 bar / 725 psi
<b>VM(60)</b>	5KIT326060	Setting 60 bar / 870 psi
<b>VM(70)</b>	5KIT326070	Setting 70 bar / 1010 psi
<b>VM(80)</b>	5KIT326080	Setting 80 bar / 1150 psi
<b>VM(90)</b>	5KIT326090	Setting 90 bar / 1300 psi
<b>VM(100)</b>	5KIT326100	Setting 100 bar / 1450 psi
<b>VM(125)</b>	5KIT326125	Setting 125 bar / 1800 psi
<b>VM(140)</b>	5KIT326140	Setting 140 bar / 2050 psi
<b>VM(160)</b>	5KIT326160	Setting 160 bar / 2300 psi
<b>VM(175)</b>	5KIT326175	Setting 175 bar / 2550 psi
<b>VM(190)</b>	5KIT326190	Setting 190 bar / 2750 psi
<b>VM(210)</b>	5KIT326210	Setting 210 bar / 3050 psi
<b>VM(230)</b>	5KIT326230	Setting 230 bar / 3350 psi
<b>VM(250)</b>	5KIT326250	Setting 250 bar / 3600 psi
<b>VM(260)</b>	5KIT326260	Setting 260 bar / 3750 psi
<b>VM(280)</b>	5KIT326280	Setting 280 bar / 4050 psi
<b>VM(300)</b>	5KIT326300	Setting 300 bar / 4350 psi
<b>VMT</b>	XTAP221340	Valve blanking plug
<b>Kit VM</b>	5CO2820020	Mounting block kit

**4. V anti-schock+anti-cavitation valve** *page 106*

Set of valves fitted with mounting block.

TYPE	CODE	DESCRIPTION
<b>Kit V</b>	5CO2820010	Mounting block kit
<b>T</b>	XTAP524280	Valve blanking plug
<b>C</b>	5KIT406110	Anti-cavitation valve

Anti-shock valves

<b>P(G2)</b>	5KIT206112	Range 60 to 125 bar / 870 to 1800 psi standard setting 80 bar / 1150 psi
<b>P(G3)</b>	5KIT206113	Range 80 to 200 bar / 1150 to 2900 psi standard setting 120 bar / 1750 psi
<b>P(G4)</b>	5KIT206114	Range 160 to 250 bar / 2300 to 3600 psi standard setting 200 bar / 2900 psi

Anti-shock + anti-cavitation valves

<b>U(G2)</b>	5KIT305112	Range 40 to 100 bar / 580 to 1450 psi standard setting 80 bar / 1150 psi
<b>U(G3)</b>	5KIT305113	Range 80 to 200 bar / 1150 to 2900 psi standard setting 120 bar / 1750 psi
<b>U(G4)</b>	5KIT305114	Range 160 to 315 bar / 2300 to 4600 psi standard setting 200 bar / 2900 psi

**5. Flow control valves** *page 110*

Flow control on every section; with auxiliary inlet

TYPE	CODE	DESCRIPTION
<b>VD21</b>	2S0PP10002000	Fine regulation from 3 to 28 l/min
<b>VD22</b>	2S1636020211	As VD11, one turn with detent
<b>VD23</b>	2S0PP10002002	12VDC proportional solenoid valve
<b>Kit VD2</b>	5CO2822020*	Mounting block kit

NOTE - Valve setting at points 1-2-4-5-6 are referred to 10 l/min flow.

- (\*) Codes are referred to **BSP** threads.

Service and auxiliary valves

VS relief valve

It's suggested for flow up to 25 l/min, and it's mounted on parallel body to limitate the pressure, at lower value than main relief valve (min. gap 20 bar / 290 psi), on downstream section.

It's in parallel with flow trough and it works only with single operation.

VS (G 3 - 100)

- Pressure setting in bar (standard 100 bar / 1450 psi)
- Spring type
- Adjustment type (G, H)

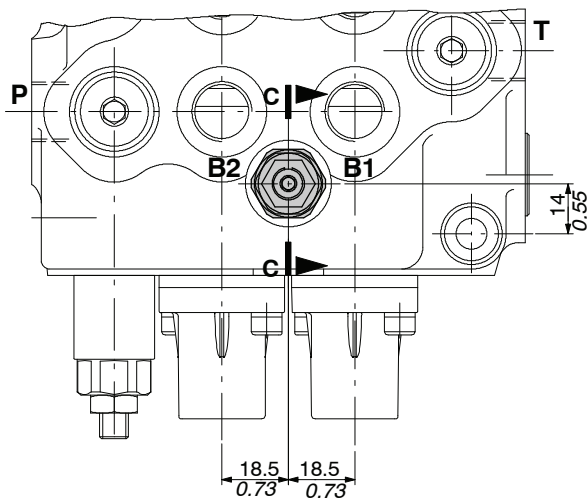

Adjustment type

G: with screw

H: valve set and locked

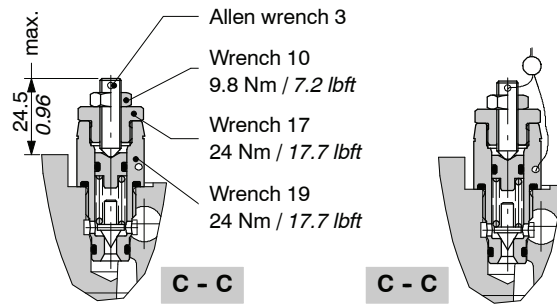

Performance data

Hydraulic circuit

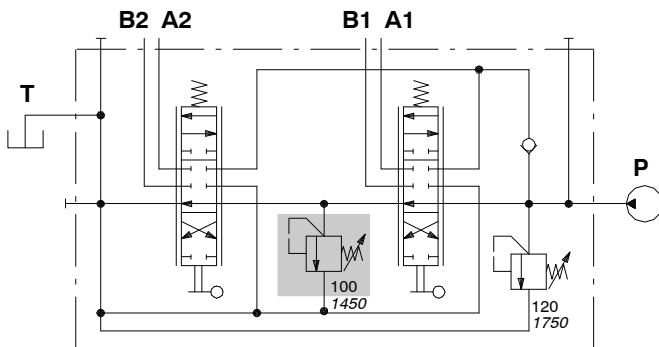

Description example:

SD5/2-P(KG3-120)/ED-18L/VS(G3-100)/ED-18L/AET-PSA

Spring nr. 3 (blue band)

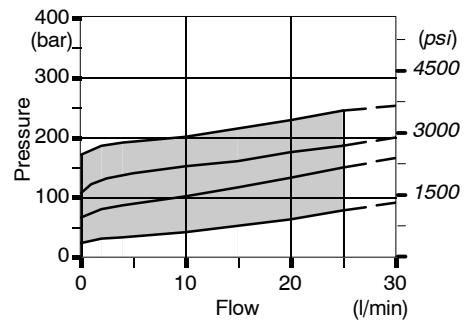

Time response

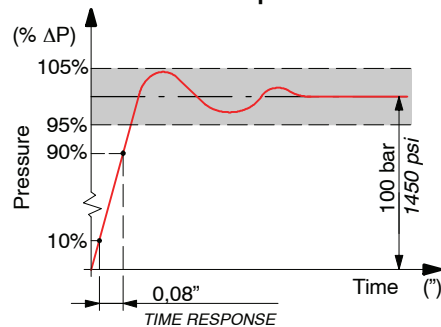

VST: valve blanking plug

Allen wrench 6  
42 Nm / 31 lbft

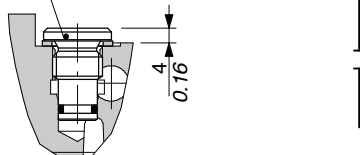

VSC relief valve

It's flange mounted on parallel body on the opposite side of working ports, the function to limit the pressure, at lower value than main relief valve (min. gap 20 bar / 290 psi) on downstream sections.

It's in parallel with flow through line and it works only with single operation.

It needs a dedicated body with extra machining: for production requirements, the block (2) is flanged (1) before the final honing of spool hole, while the valve (3) is mounted during final assembling phase.

For information contact Sales Department.

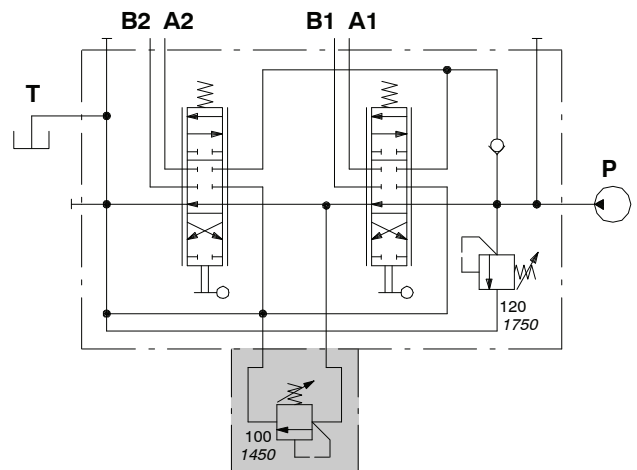
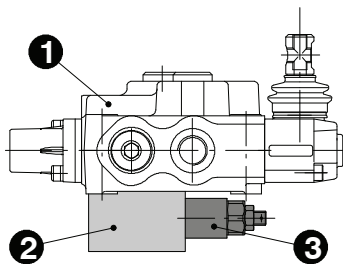

VSC ( J G 3 - 100 )

Standard setting in bar (for value see page 101)

Adjustable spring type (2, 3, 4).

Adjustment type (G, H).

Description example:

SD5/2-P(JG3-120)/ED-18L/VSC(JG3-100)/ED-18L/AET

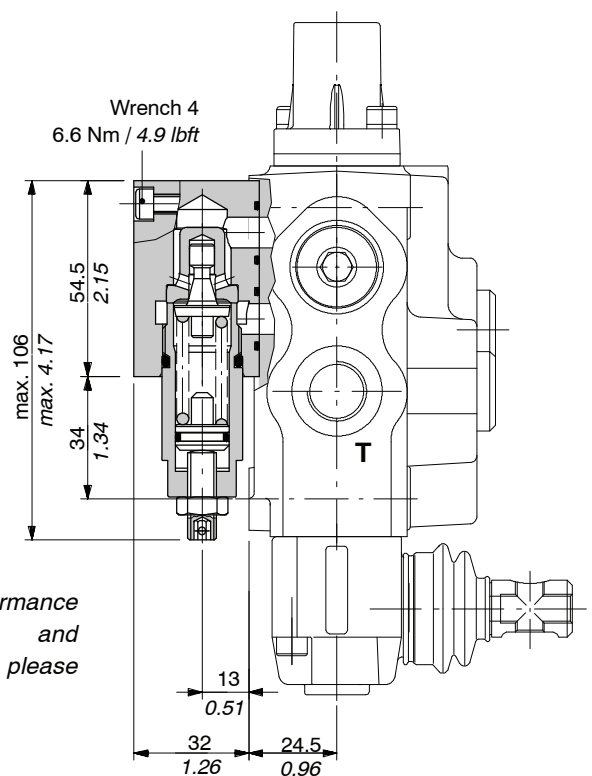
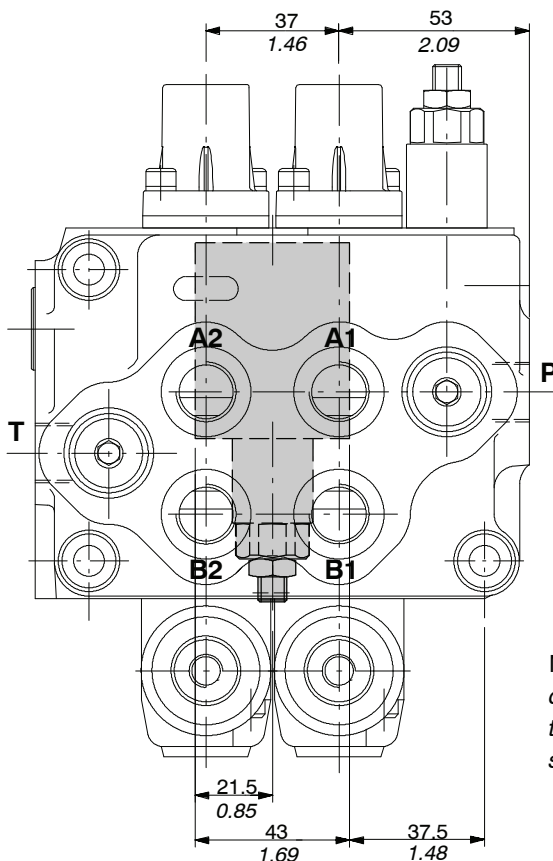

NOTE - For performance data, wrench and tightening force, please see page 12.

## Service and auxiliary valves

## VM anti-shock and anti-cavitation

They are flange mounted on the opposite side of working ports, connected in parallel with A and B ports and with outlet on T port. It needs a dedicated body with extra machining: for production requirements, the block (2) is flanged on body (1) before the final honing of spool hole, while the valve (3) is mounted during final assembling phase.

For information contact Sales Department.

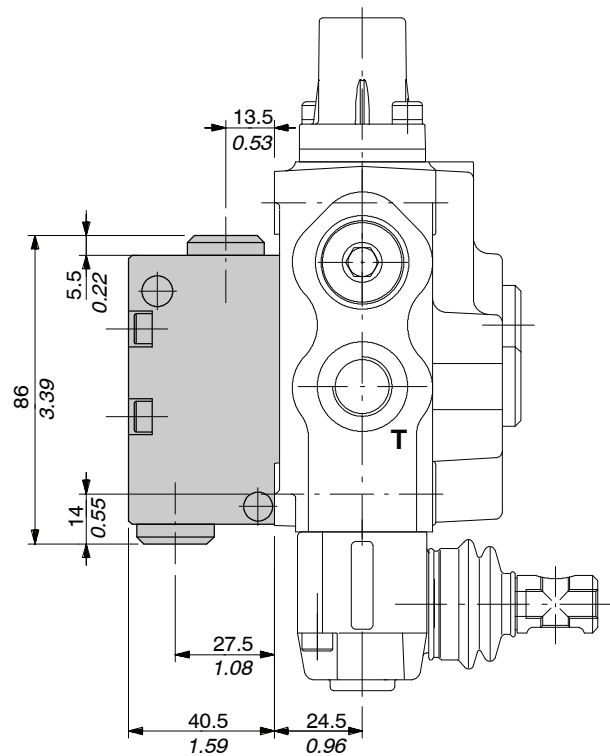
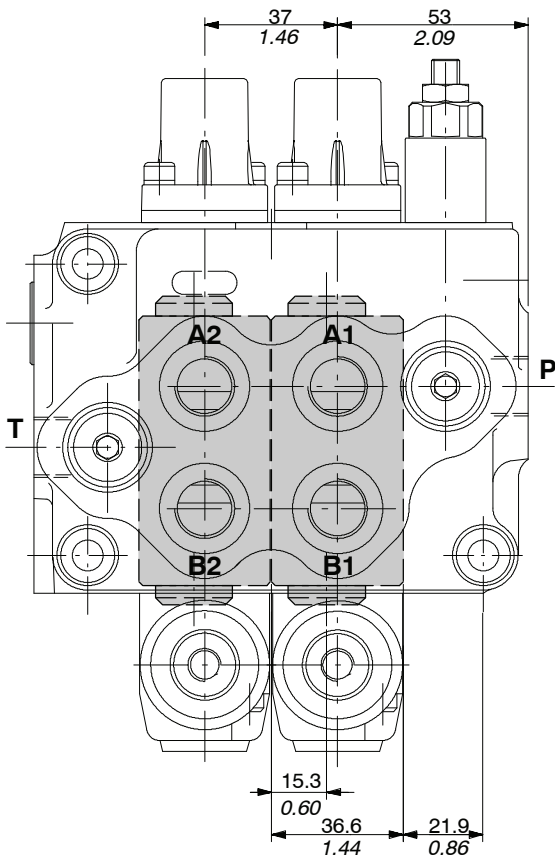
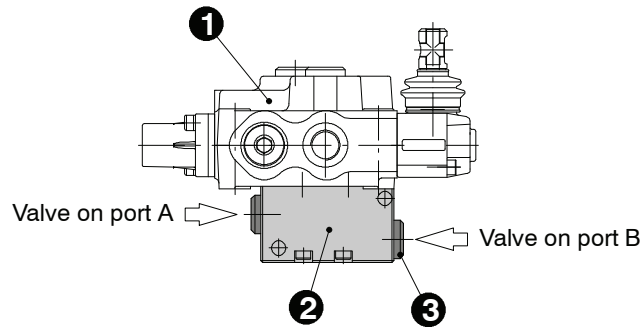



VM anti-shock and anti-cavitation

VM 1 (100)

- Valve setting in bar
- 1 mounted on port A
  - 2 mounted on port B
  - 3 mounted on ports A and B

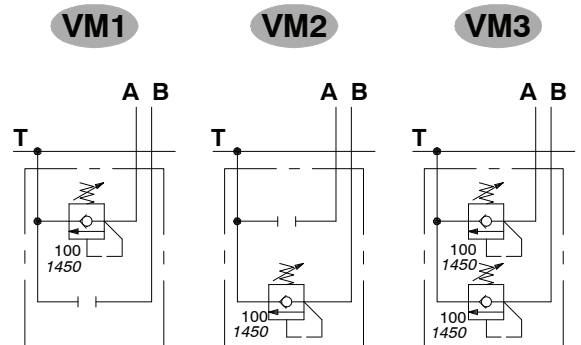

Example of VM1 configuration

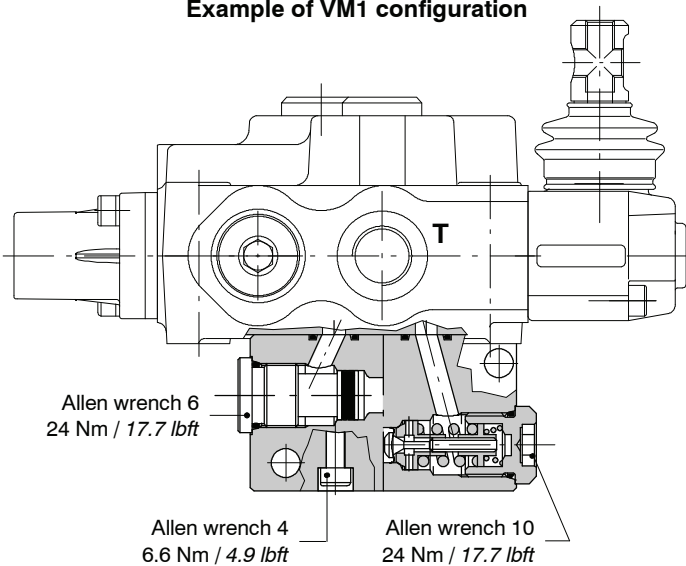

Pressure-flow diagram

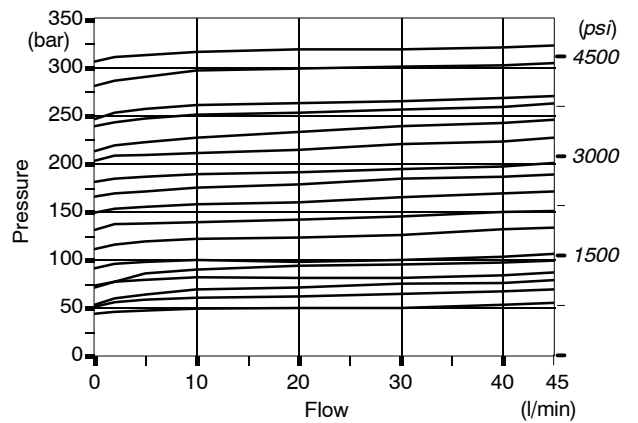

Service and auxiliary valves

V anti-shock and anti-cavitation

They are anti-shock (VP), anti-shock and anti-cavitation (VU) and anti-cavitation (VC) service valves, flange mounted on the opposite side of working ports connected in parallel with A and B ports.

They need a dedicated body with extra machining: for production requirements, the blocks (2) are flanged on body (1) before the final honing of spool hole, while the valves (3) are mounted during final assembling phase.

For information contact Sales Department

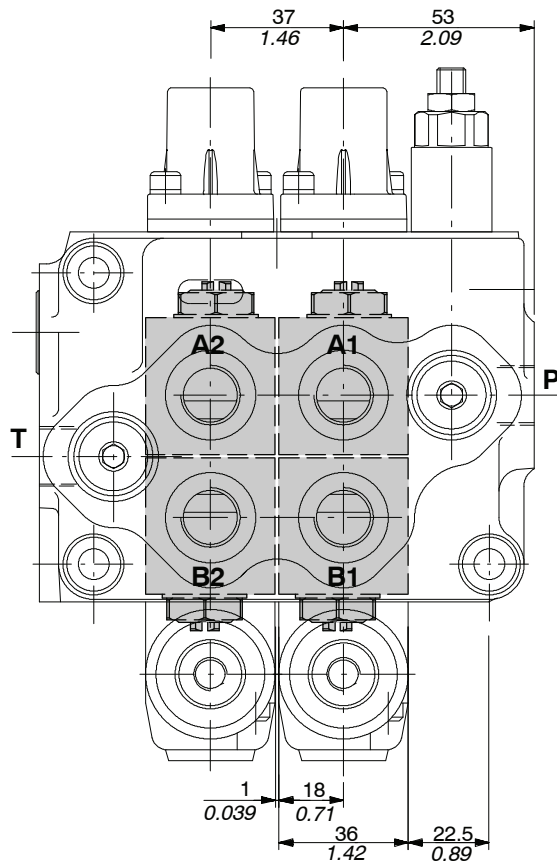
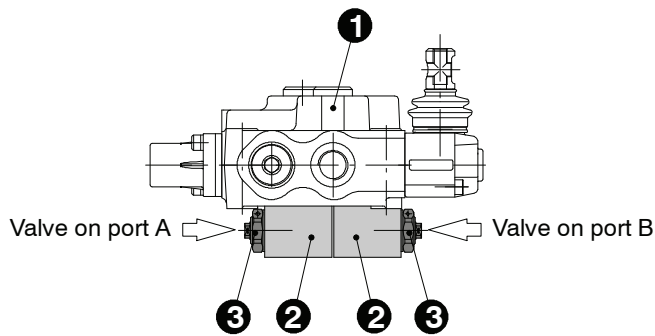

Dimension D value (mm / in)			
VP	VU	VC	VT
14 / 0.55 max.	14 / 0.55 max.	9.5 / 0.37	5.5 / 0.22

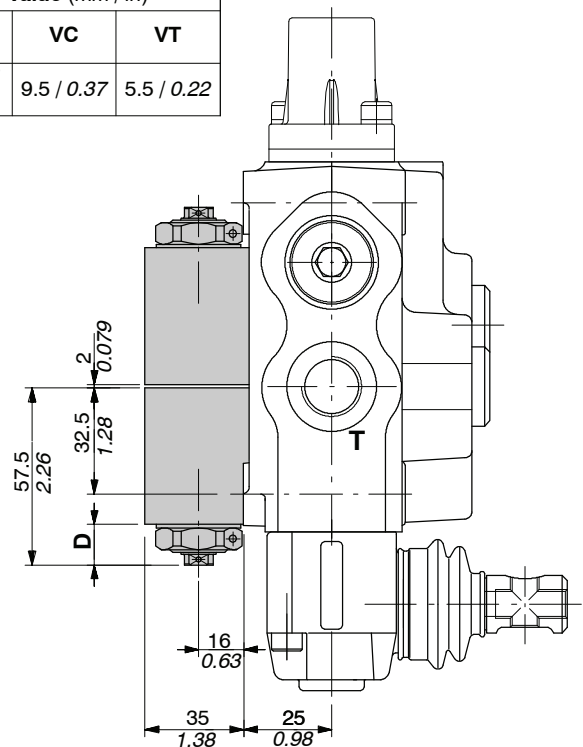

V anti-schock+anti-cavitation valves

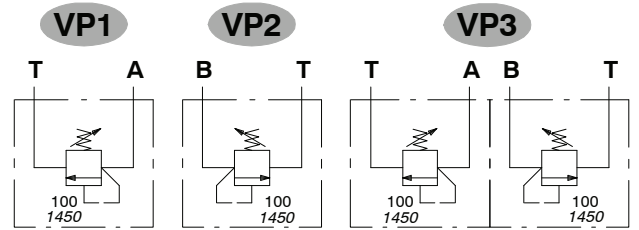
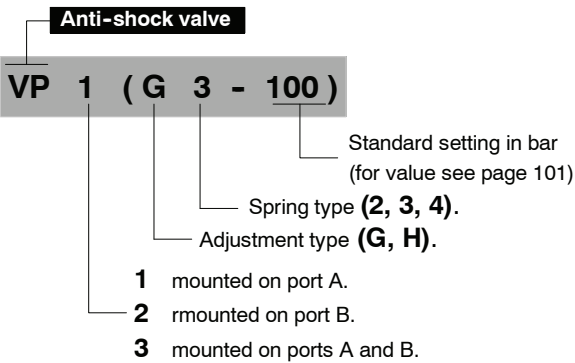

Adjustment type

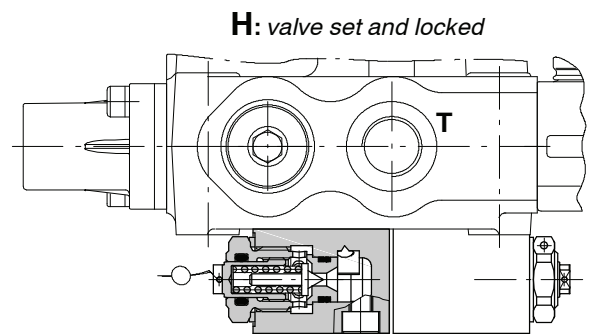
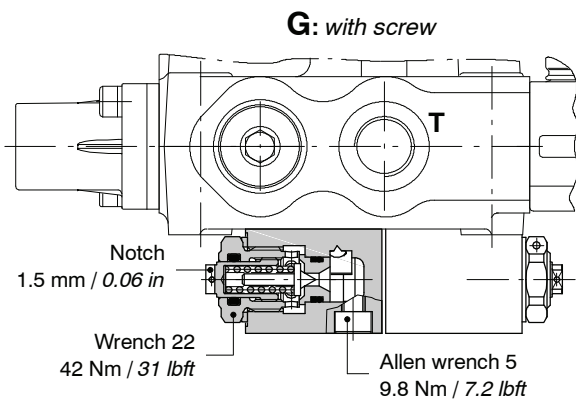

Performance data

Spring nr. 2 (green band)

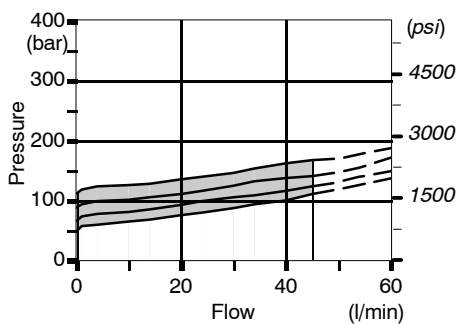

Spring nr. 3 (blue band)

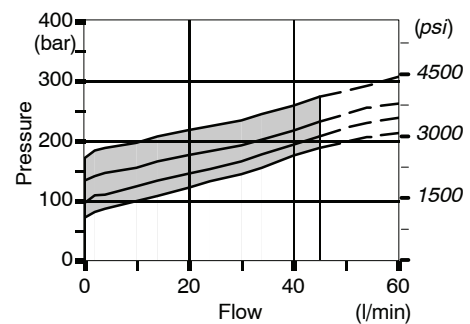

Spring nr.4 (red band)

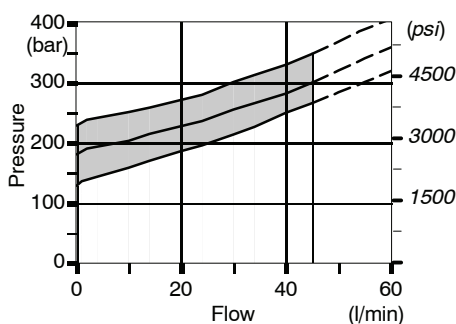

Time response

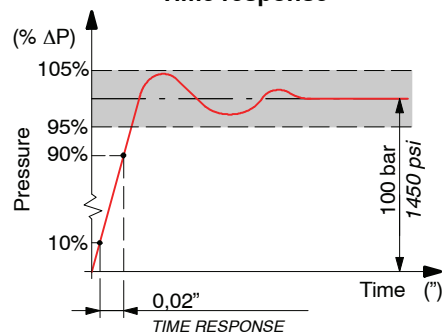

Service and auxiliary valves

V anti-shock and anti-cavitation

**Anti-shock + anti-cavitation valve**

**VU 1 ( G 3 - 100 )**

Standard setting in bar  
(for value see page 53)

Spring type (2, 3, 4).

Adjustment type (G, H).

1 mounted on port A.  
2 mounted on port B.  
3 mounted on ports A and B.

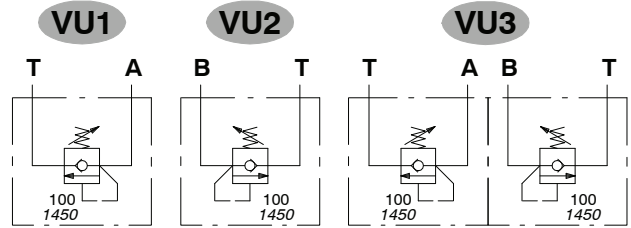

Adjustment type

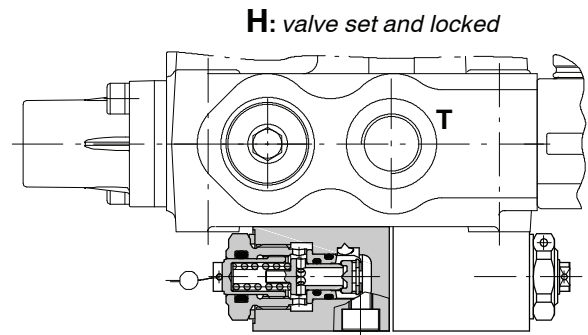
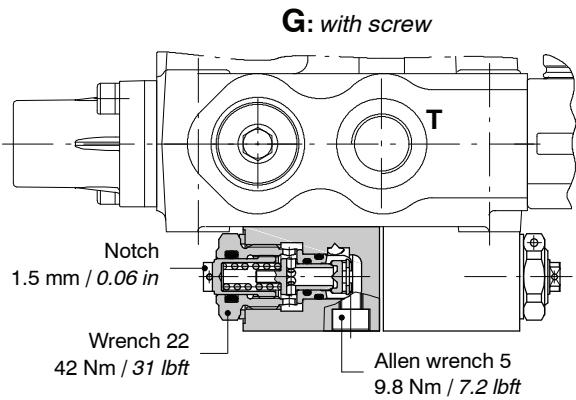

Performance data

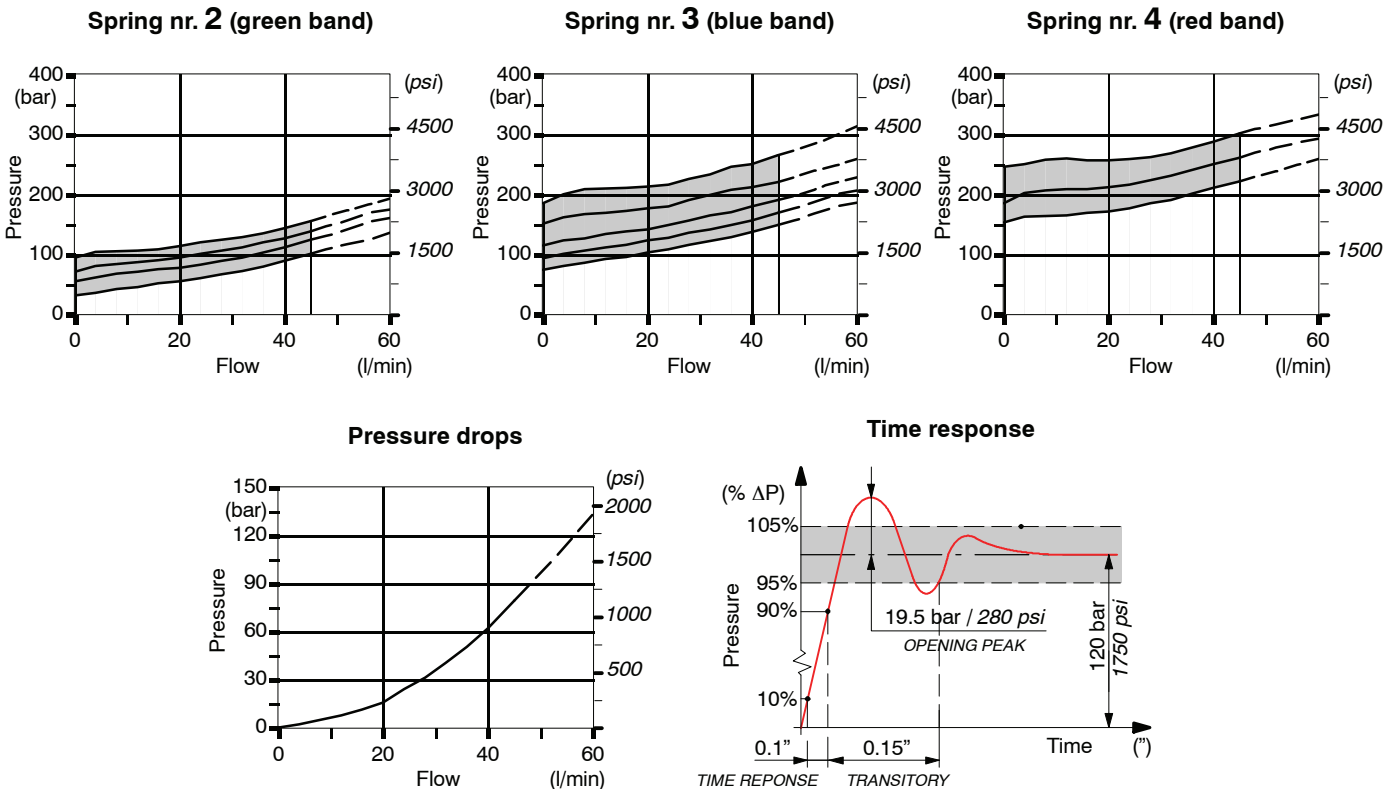

V anti-shock and anti-cavitation

Anti-cavitation valve

VC 1

- 1 mounted on port A.
- 2 mounted on port B.
- 3 mounted on ports A and B.

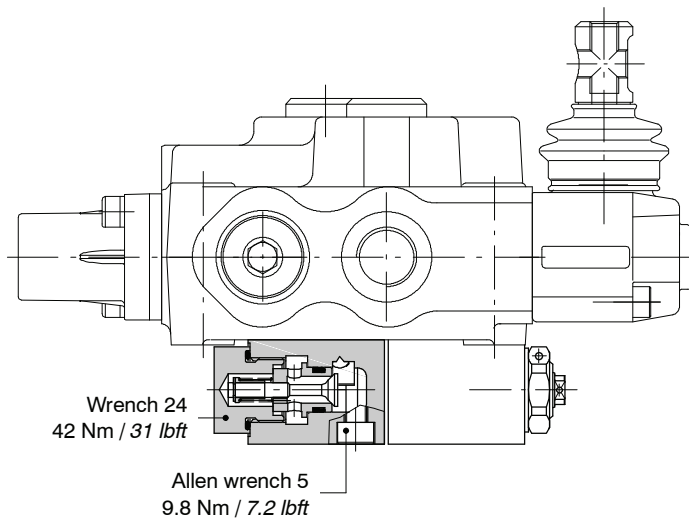
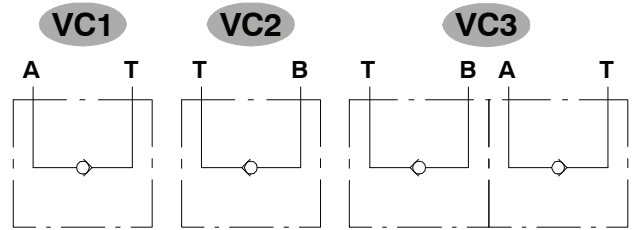

Perdita di carico

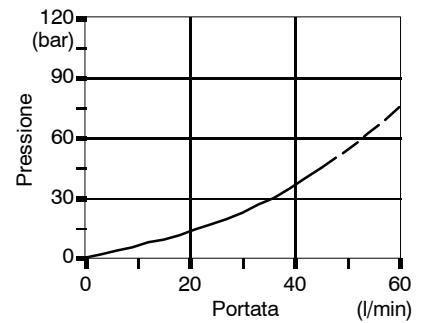

Valve blanking plug

VT 1

- 1 mounted on port A.
- 2 mounted on port B.
- 3 mounted on ports A and B.

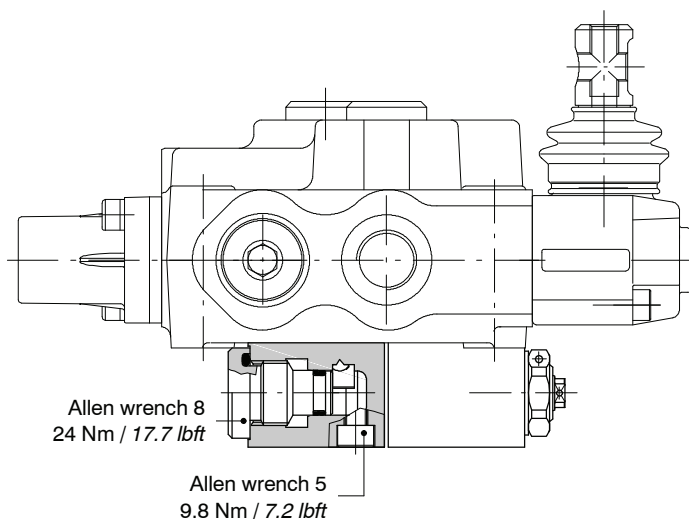
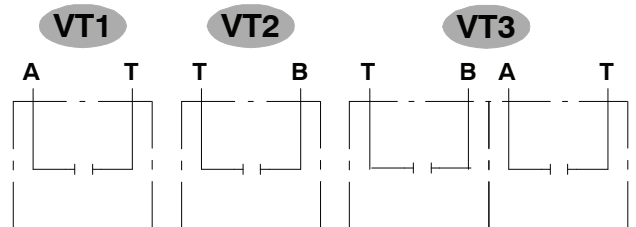

Service and auxiliary valves

VD2 flow control valves

Block with pressure compensated 3-way flow control valve, to be flange mounted on body with parallel circuit.

The cavity is oriented toward lever side.

The flow is regulated on every working section while the exceeding flow goes to tank: max. regulated flow 28 l/min (with inlet on P1 port).

It needs a dedicated body with extra machining: for production requirements, the block (2) is flanged (1) before the final honing of spool hole, while the valve (3) is mounted during final assembling phase.

For information contact Sales Department.

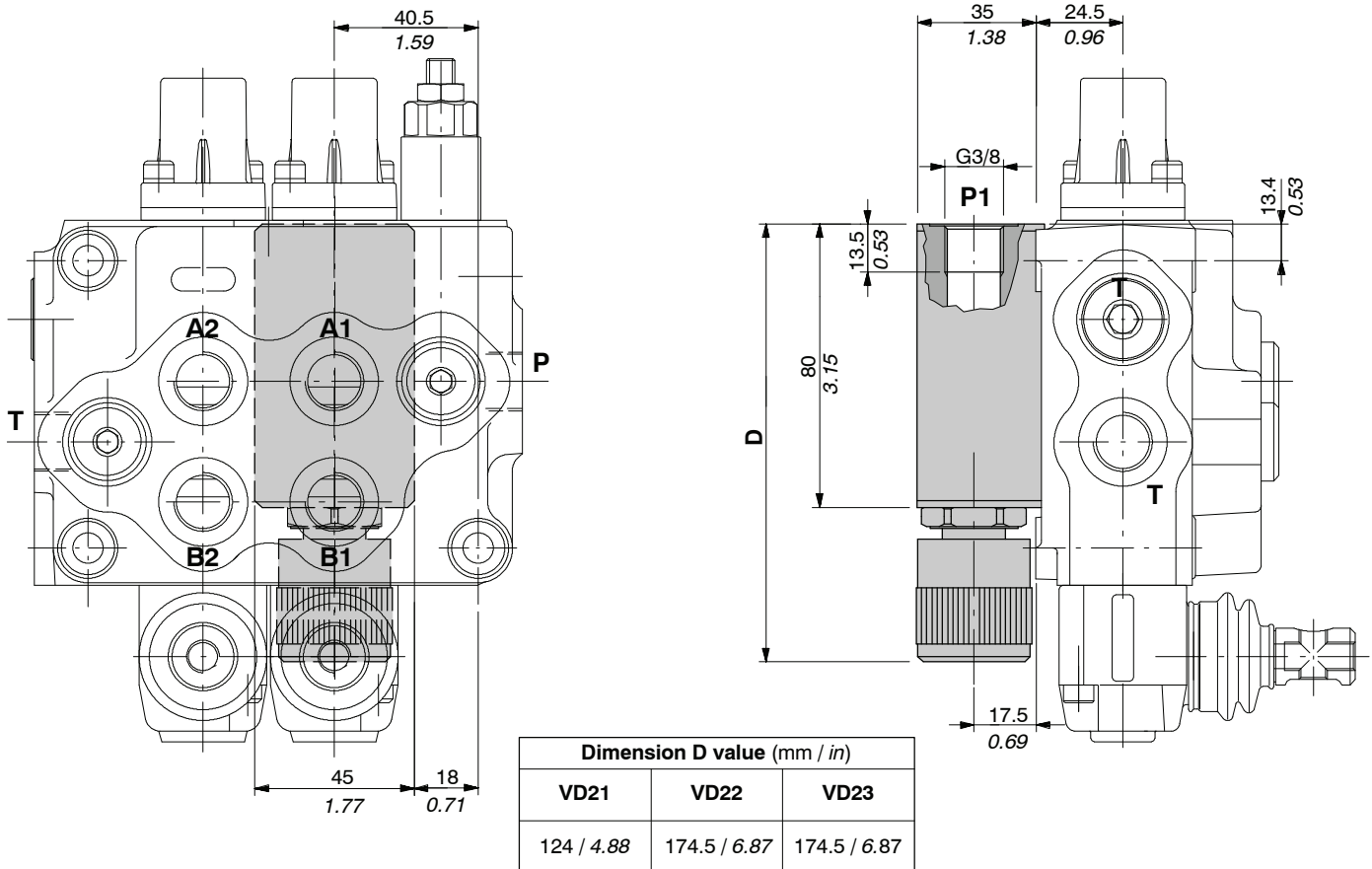
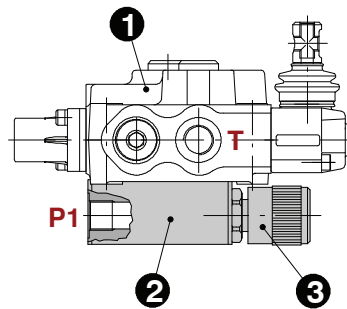

VD2 flow control valves

Manual control

VD21: continuous fine regulation

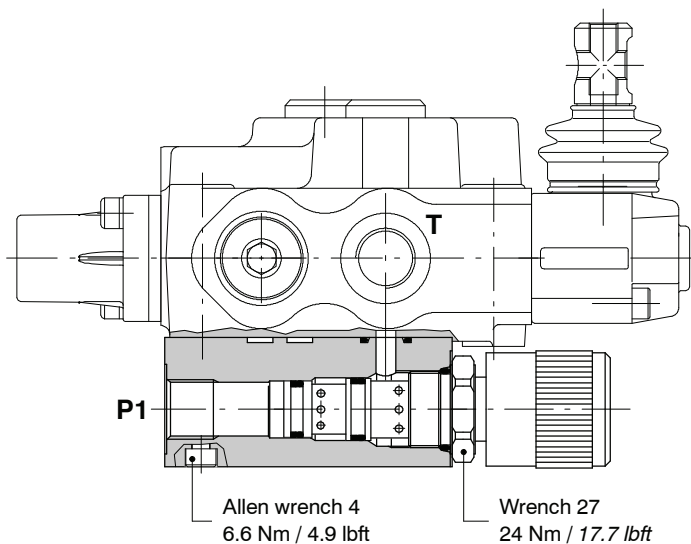

Description example: SD5/2-P(JG3-120)VD11/ED-18L/ED-18L/AET

Hydraulic circuit

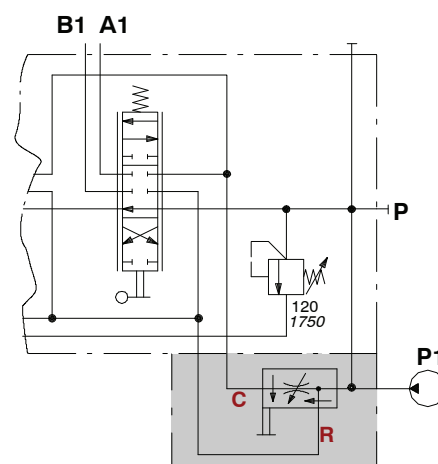

VD22: one turn with detent handknob regulated

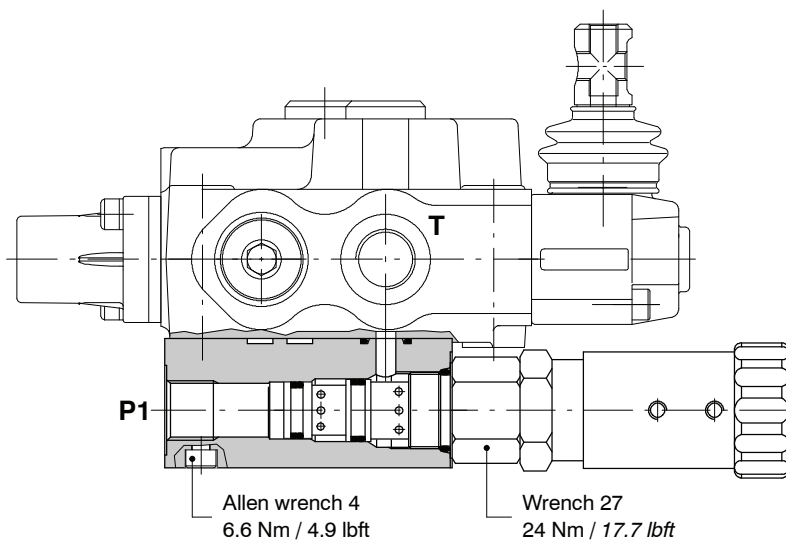

Description example: SD5/2-P(JG3-120)VD12/ED-18L/ED-18L/AET

Service and auxiliary valves

VD2 flow control valves

VD13 with proportional solenoid control

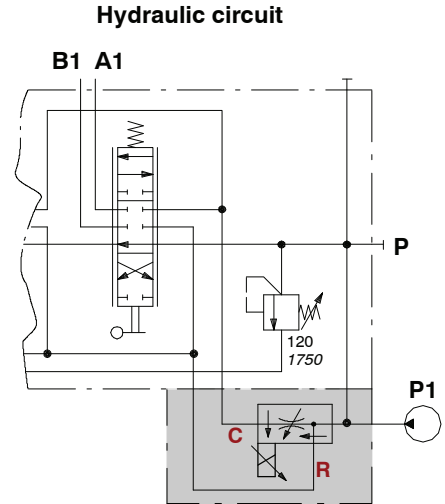
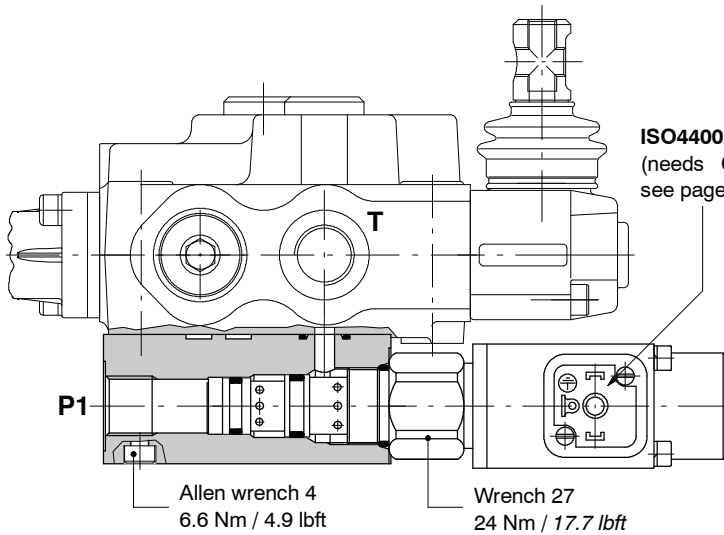

Description example: SD5/2-P(JG3-120)VD13/ED-18L/ED-18L/AET

Proportional solenoid flow control valve connection

It's shows a configuration with push-button panel type UPA.

For information contact Sales Department.

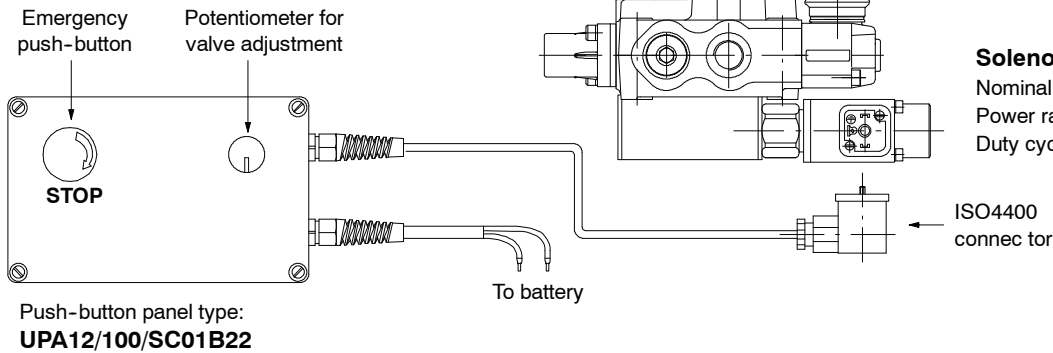

Performance data

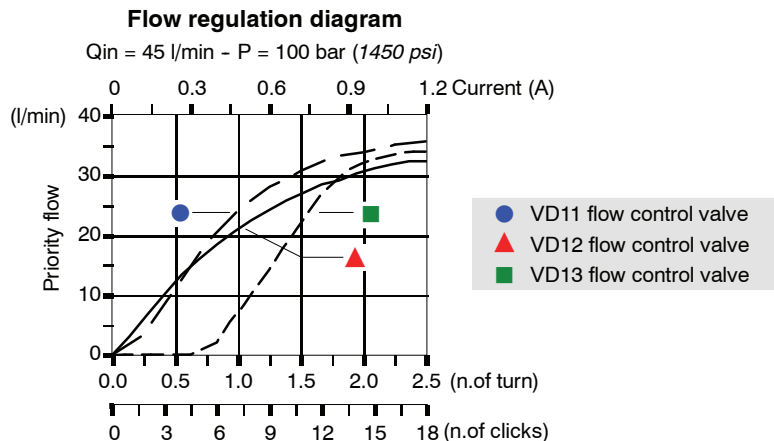
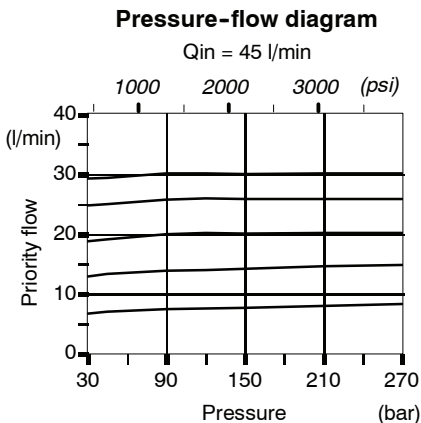



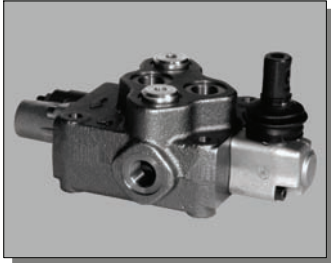

**SD5/1-N** ..... page 114

It's available only with one working section and it can be used in hydraulic circuits where carry-over doesn't required.

- For controls, spool positioning and valves, refer to directional valve with parallel circuit.

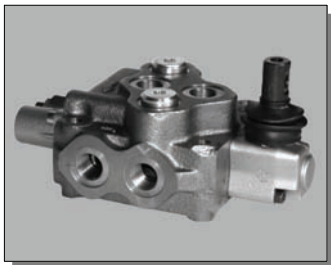

**SD5/1-D** ..... page 115

It's available only with one working section and it can be used in hydraulic circuits where carry-over is required.

- For controls and spool positioning refer to directional valve with parallel circuit.
- Configurations with service and auxiliary valves aren't available



**SD5-S: with series circuit** ..... page 116

Available from 2 to 6 sections, it can be used in systems with one downstream section from series connection must work with upstream ones at the same time.

- On the same body are possible more than one connection.
- It's not available the carry-over circuit.
- For controls, spool positioning and valves, refer to directional valve with parallel circuit.



**SD5-SP: with tandem circuit** ..... page 118

Available from 2 to 6 sections, for security reasons it can be used in systems which is required to prohibit engagement of downstream sections from tandem connection when the upstream sections are working.

- On the same body are possible more than one connection.
- For controls, spool positioning and valves, refer to directional valve with parallel circuit.



**SDM105: with flow control valve** ..... page 120

One section available.

- It can be configured with unloader valve.
- For controls and spool positioning refer to directional valve with parallel circuit.
- Configurations with service and auxiliary valves aren't available.

## Dimensional data

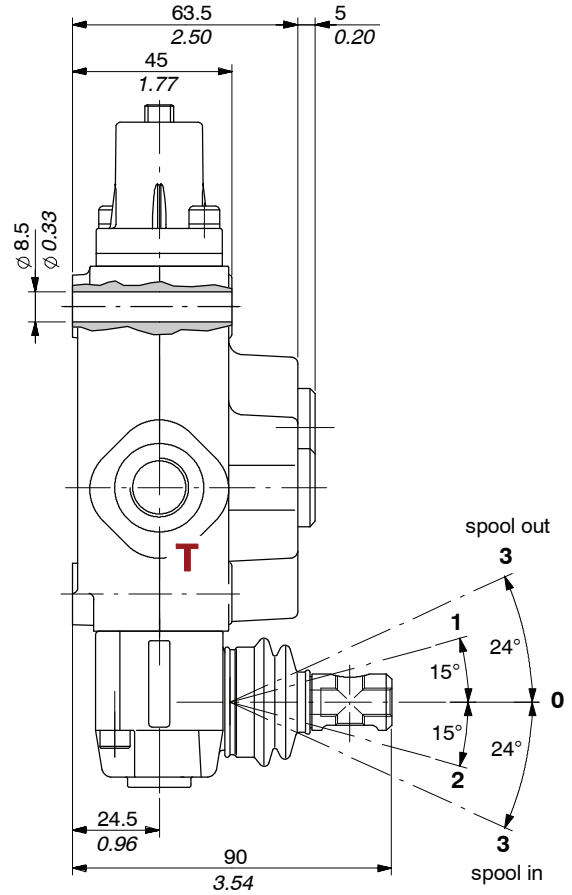
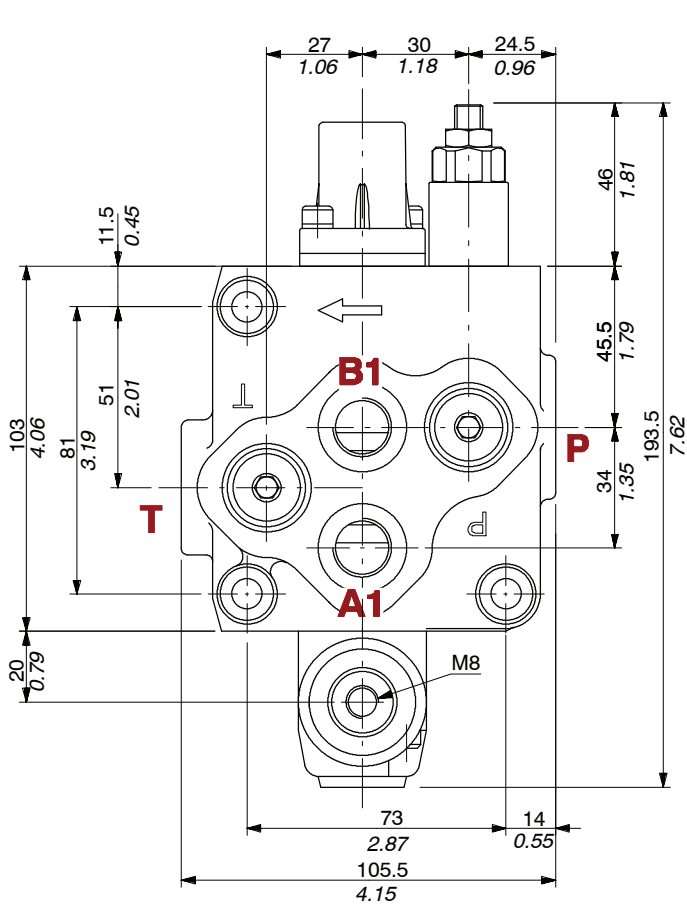

## Hydraulic circuit

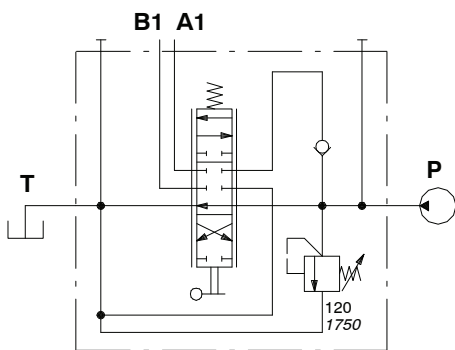

Description example  
SD5/1-N(JG3-120)/ED-18L  
Code: 102110033

## Performance data

Pressure drop curve

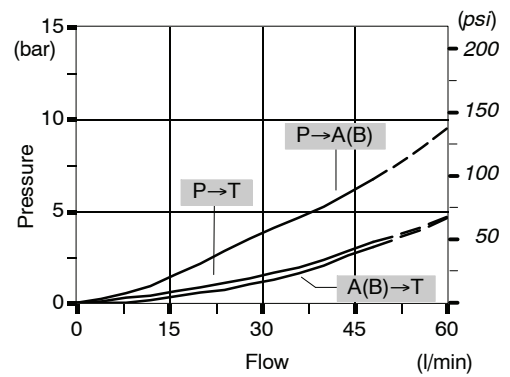

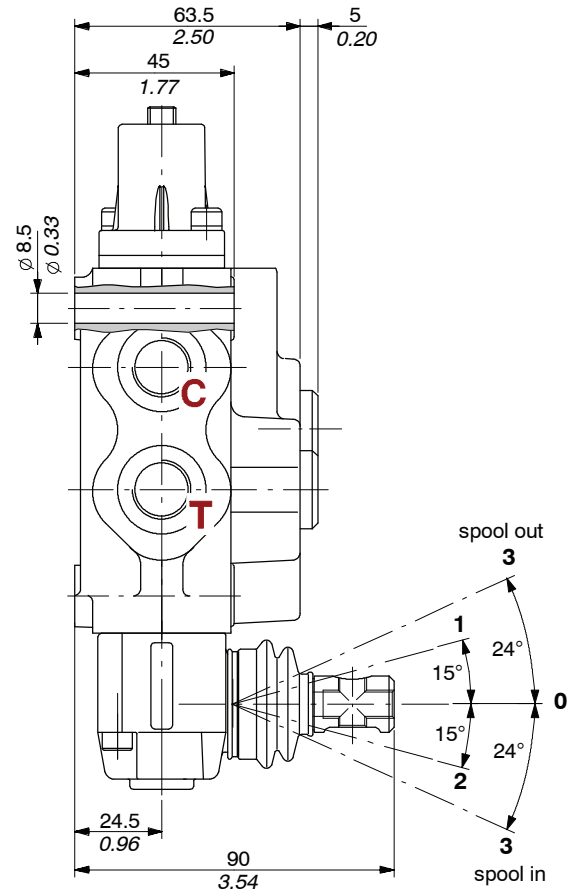
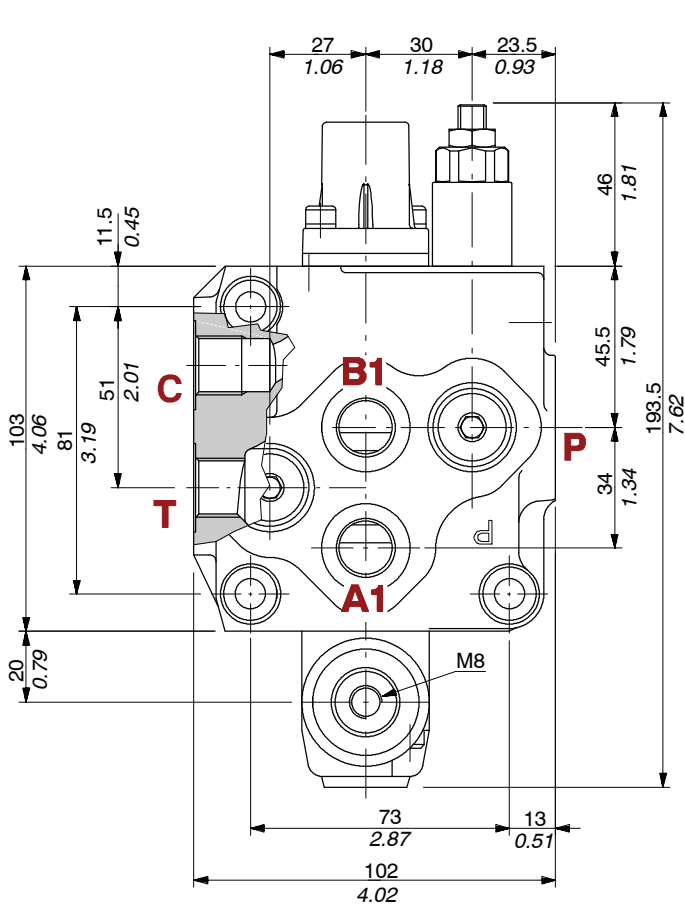

Hydraulic circuit

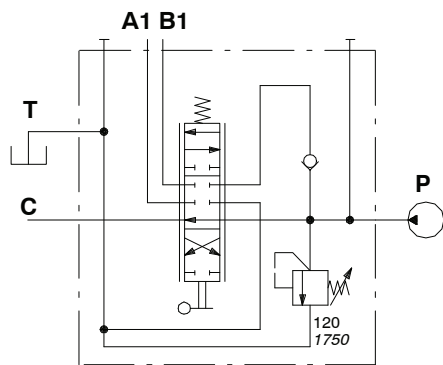

Description example:  
SD5/1-D(JG3-120)/ED-18L  
Code: 102160027

Performance data

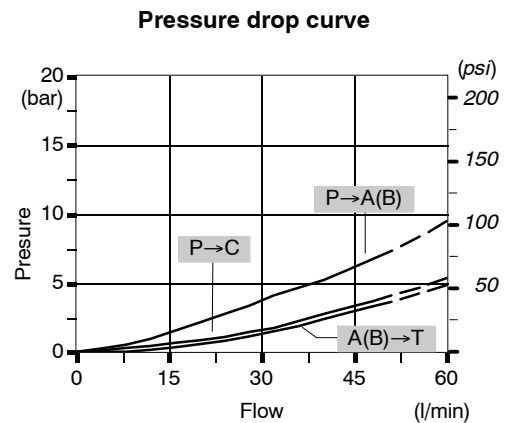

### Dimensional data

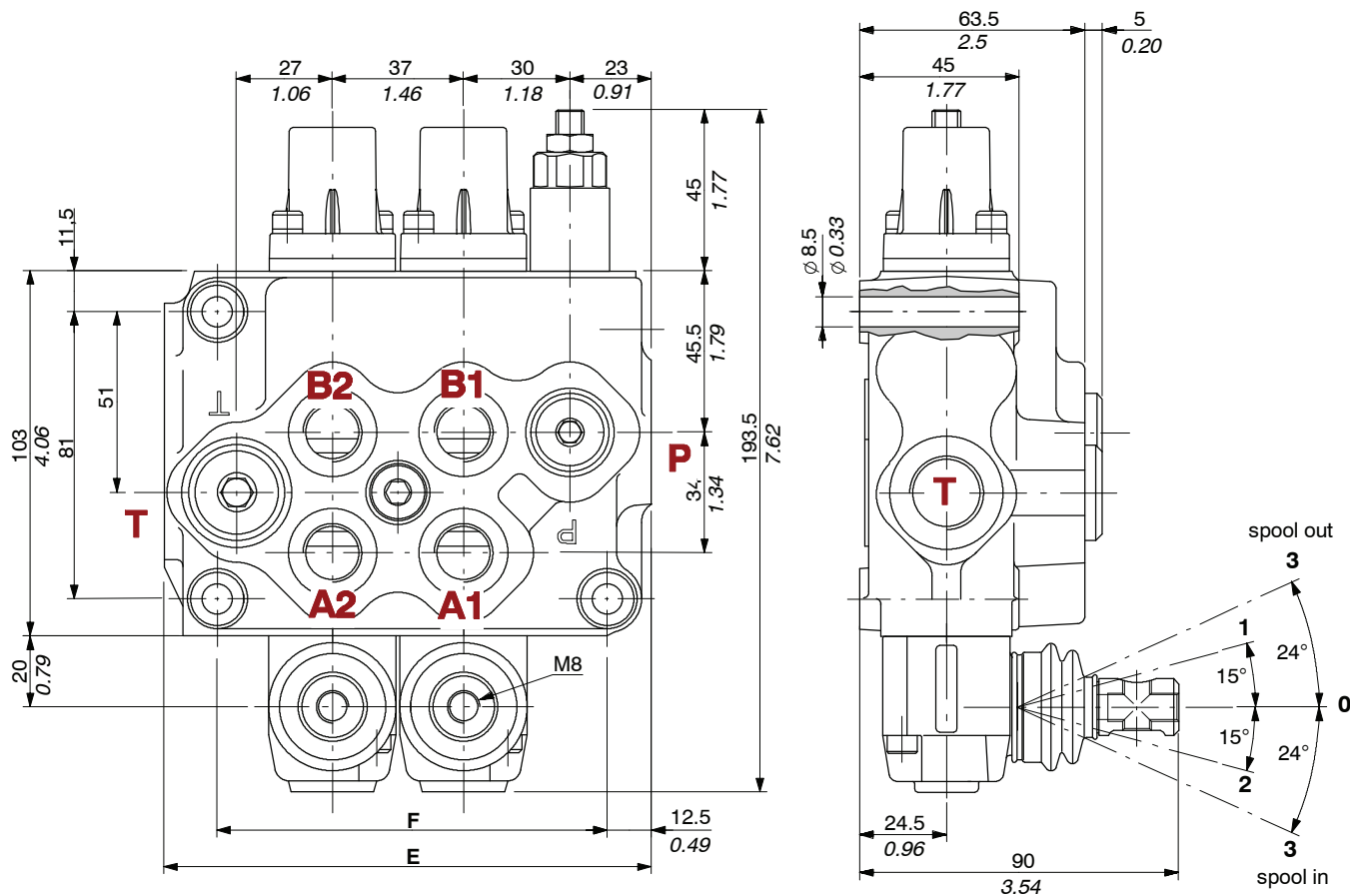

TYPE	E		F		Weight	
	mm	in	mm	in	kg	lb
SD5/2-S	137.5	5.41	110	4.33	5.2	11.4
SD5/3-S	174.5	6.87	147	5.79	6.9	15.2
SD5/4-S	211.5	8.33	184	7.24	8.1	17.9

TYPE	E		F		Weight	
	mm	in	mm	in	kg	lb
SD5/5-S	248.5	9.78	221	8.70	10.1	22.3
SD5/6-S	285.5	11.2	258	10.2	11.7	25.8

Hydraulic circuit

The description of SD5 valve with series circuit is marked with letter "S" and one figure wich indicate the downstream sections from series connection.

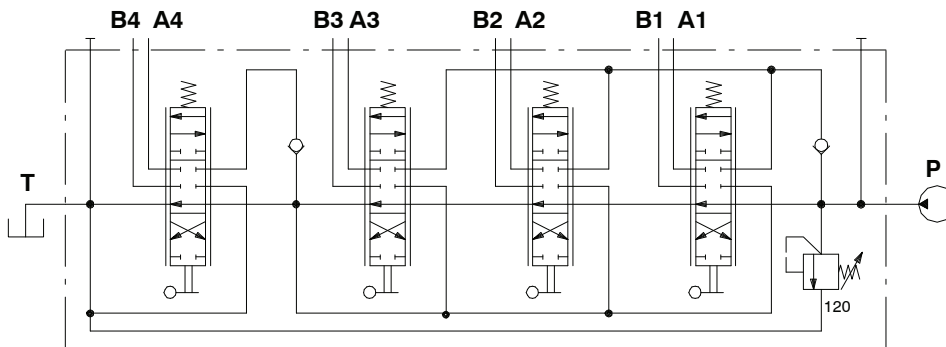

Available body kits \*

CODE	DESCRIPTION
5KC1153040	SD5/2-S1
5KC1253003	SD5/3-S1
5KC12D3000	SD5/3-S1+1
5KC1283003	SD5/4-S1
5KC12E3000	SD5/4-S1+1+1
5KC1324033	SD5/5-S1
5KC1073001	SD5/5-S1+1+1+1
5KC13A3000	SD5/5-S2+1
5KC1363003	SD5/6-S1

Include boby, seals and load check valves.

Description example:

SD5/4-S1(JG3-120)/ED-18L/ED-18L/ED-18L/ED-18L

NOTE (\*) - Codes are referred to **BSP** thread.

Performance data

Pressure drop P→T

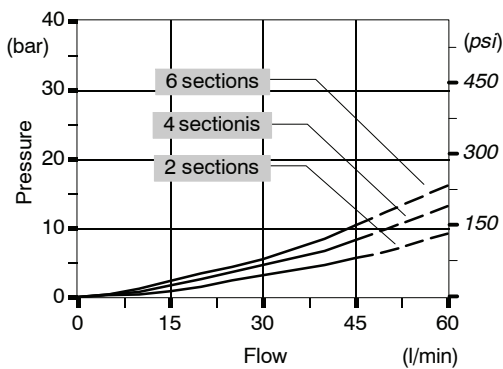

Pressure drop P→A(B)

on 6 sections directional valve

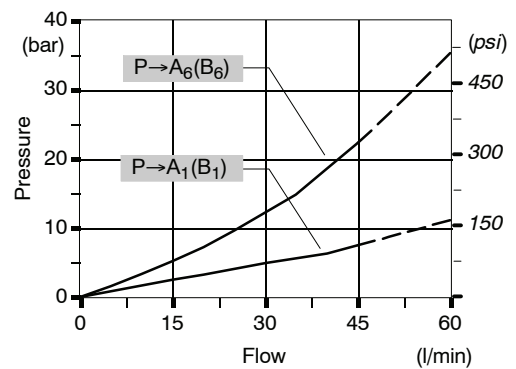

Pressure drop A(B)→T

on 6 sections directional valve

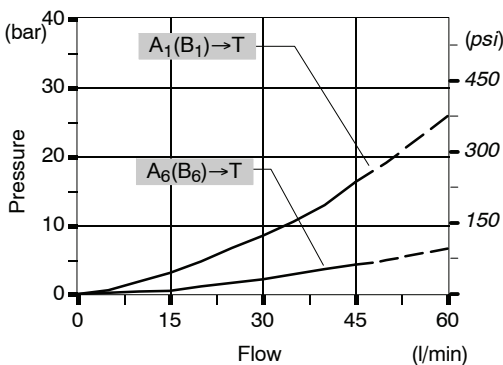

Pressure drop

between port A(B) before series connection and port A(B) after

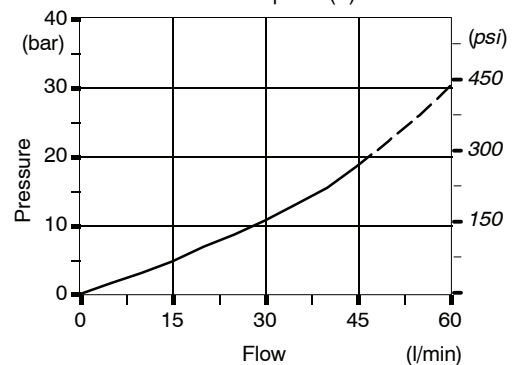

## Dimensional data

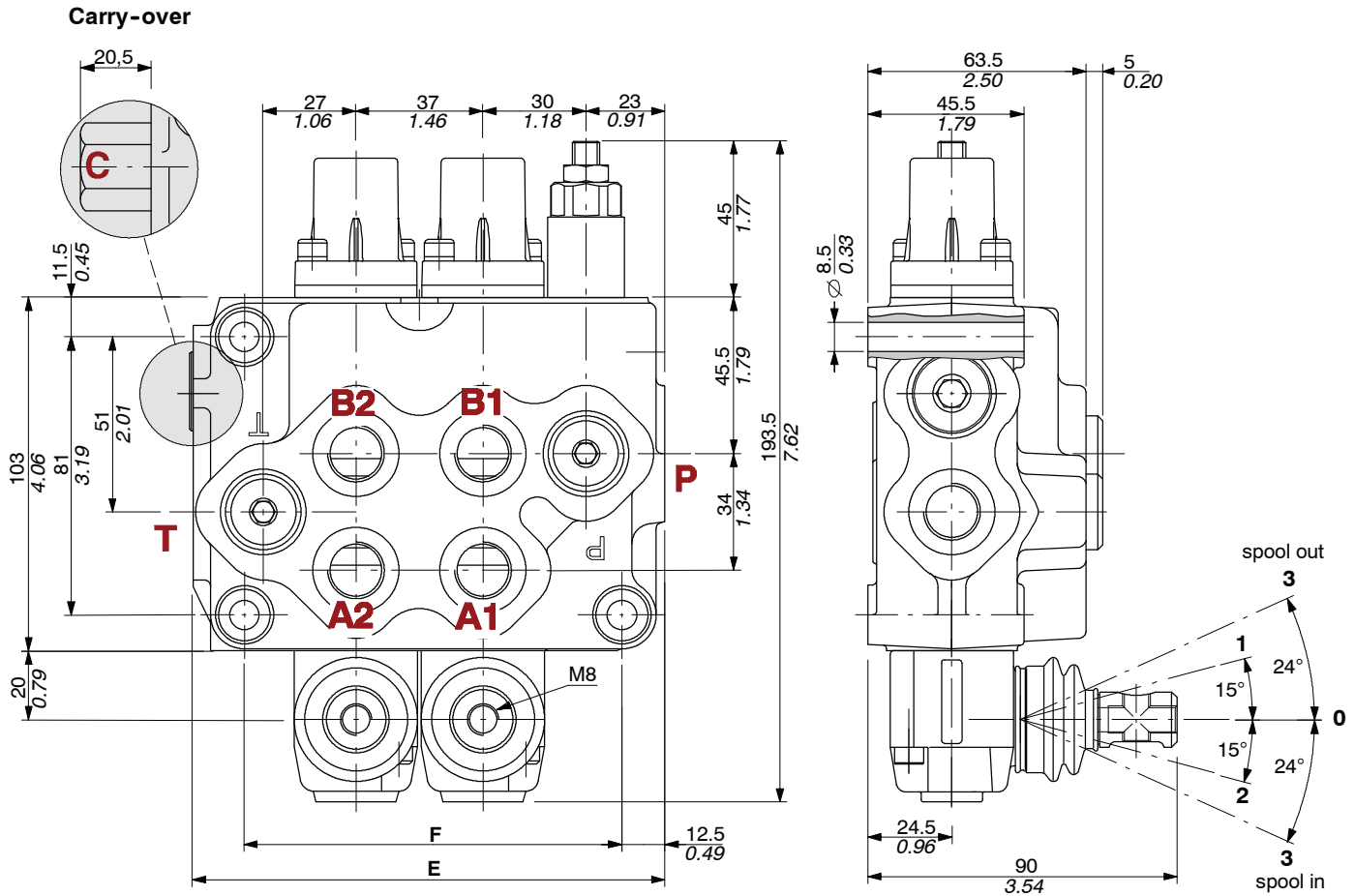

TYPE	E		F		Weight	
	mm	in	mm	in	kg	lb
SD5/2-SP1	137.5	5.41	110	4.33	4.8	10.6
SD5/3-SP2	174.5	6.87	147	5.79	6.7	14.8
SD5/4-SP3	211.5	8.33	184	7.24	8.1	17.6

TYPE	E		F		Weight	
	mm	in	mm	in	kg	lb
SD5/5-SP4	248.5	9.78	221	8.70	10.2	22.5
SD5/6-SP5	285.5	11.2	258	10.2	11.3	24.9
SD5/7-SP6	322.5	13.1	295	11.6	12.7	28

The description of SD5 valve with tandem circuit is marked with letters "SP" and one figure which indicate the downstream sections from tandem connection.

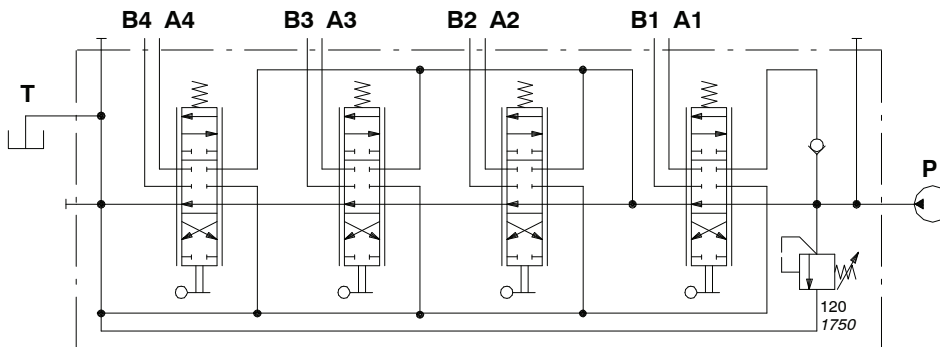

Description example:

SD5/4-**SP3**(JG3-120)/ED-18L/ED-18L/ED-18L/ED-18L/AET

Available body kits \*

CODICE	DESCRIZIONE
5KC1183000	SD5/2-SP1
5KC12G3000	SD5/3-SP2
5KC1303000	SD5/4-SP1
5KC12H3000	SD5/4-SP1+1
5KC12I3000	SD5/4-SP2+1
5KC1293000	SD5/4-SP3
5KC13D3000	SD5/5-SP2+2
5KC1343000	SD5/5-SP3+1
5KC1333000	SD5/5-SP4
5KC1393000	SD5/6-SP3+1
5KC13Y3000	SD5/6-SP3+2
5KC1373000	SD5/6-SP5
5KC13I3000	SD5/7-SP3+1
5KC13G3000	SD5/7-SP4
5KC13L3000	SD5/7-SP5+1
5KC13F3000	SD5/7-SP6

Include body, seals and load check valve.

NOTE (\*) - Codes are referred to **BSP** threads.

Performance data

Pressure drop P→T

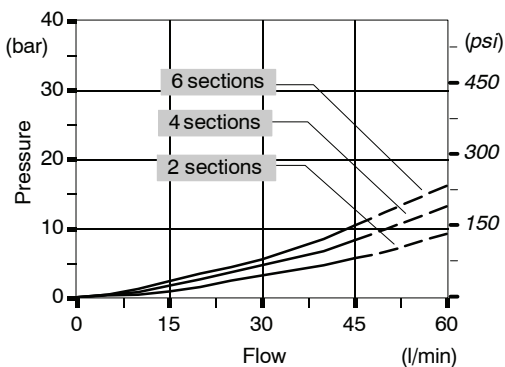

Pressure drop P→A(B)

on 6 sections directional valve

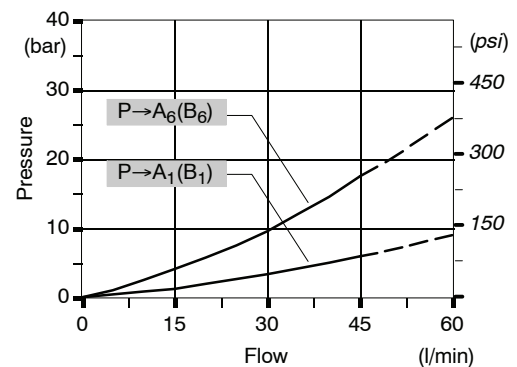

Pressure drop A(B)→T

on 6 sections directional valve

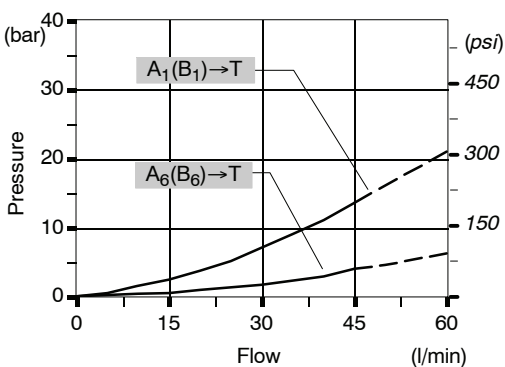

**Dimensional data**

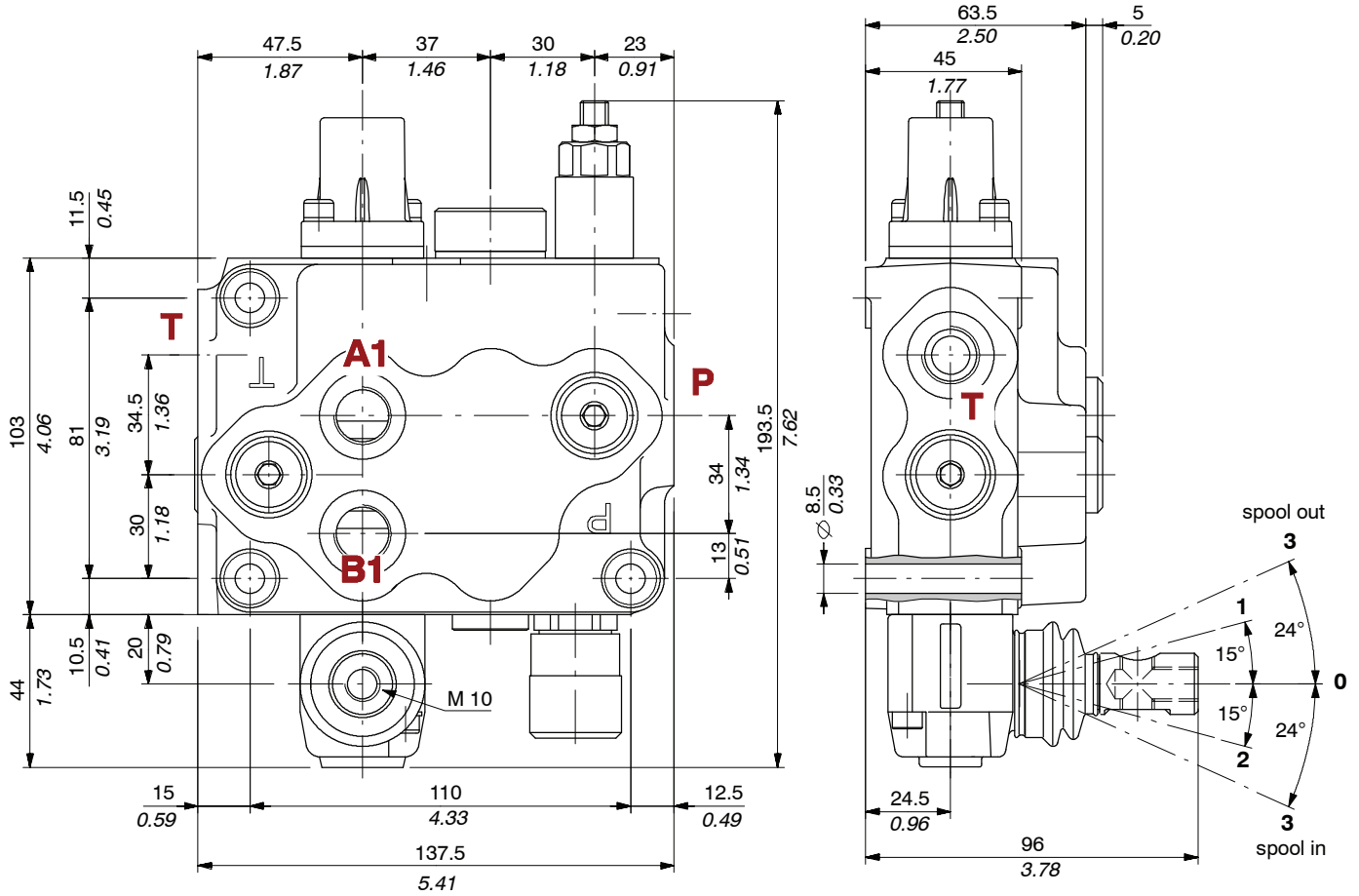



Hydraulic circuit

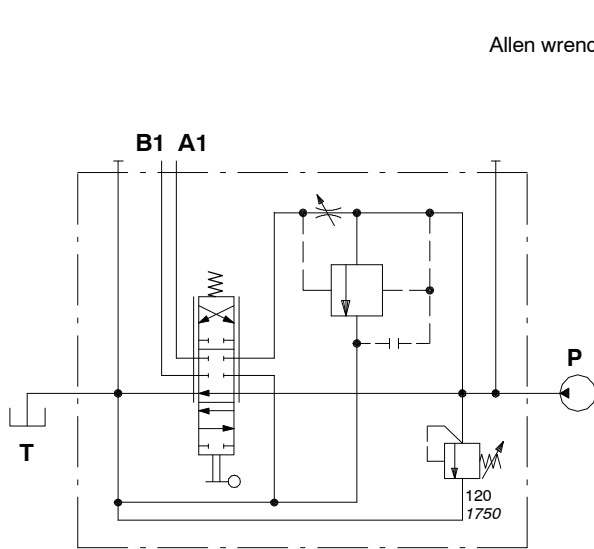

Description example:  
SDM105/1(JG3-120)M/110L/LT

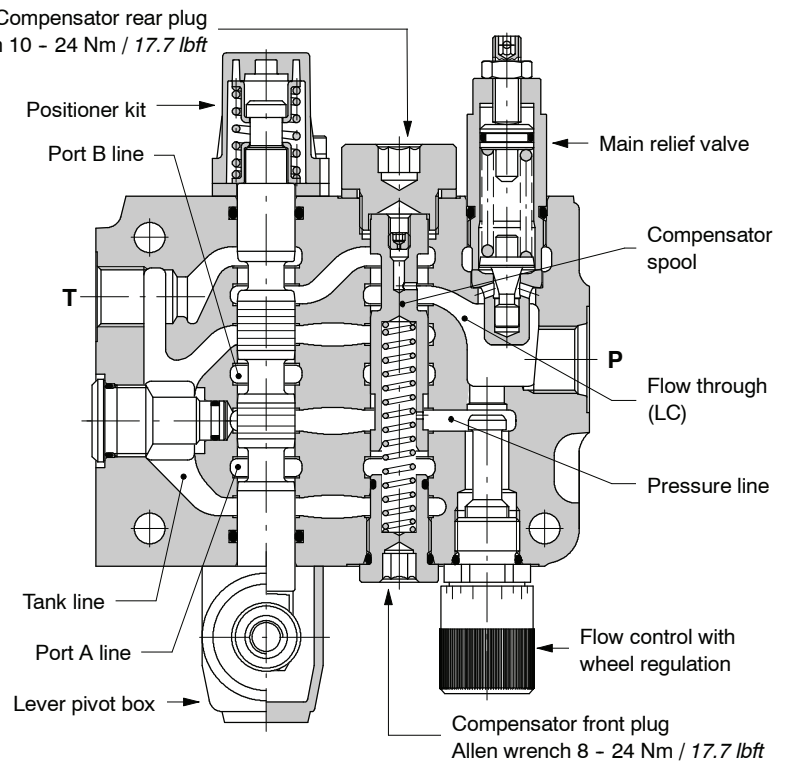

Performance data

Pressure drop P→T

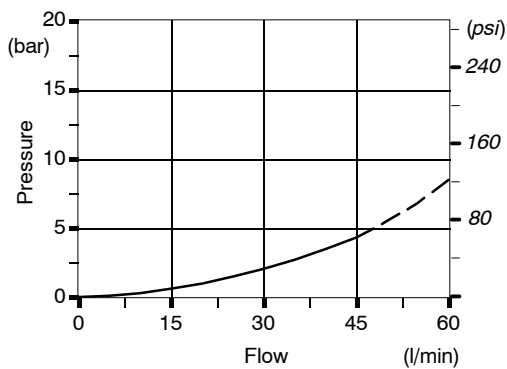

Pressure drop P→A(B)

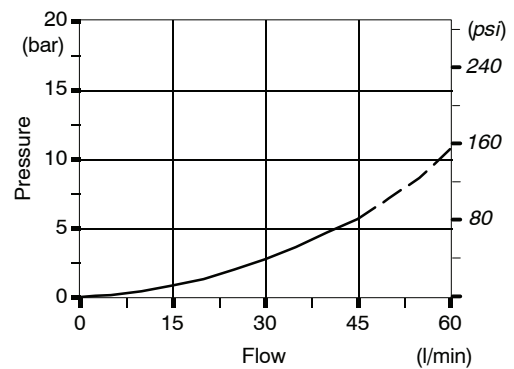

Pressure drop A(B)→T

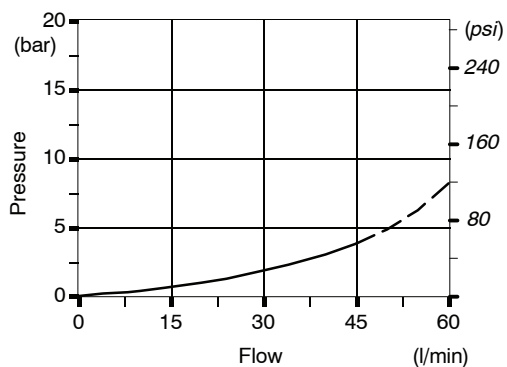

## Ordering codes

### Description example:

Valve setting in bar

SDM105 / 1 - P (JG3-120) M / 2 10 L / EL-12VDC - .....

1. 2. 3. 5. 6. 7. 9. 10.

SDM105 / 1 - P (JG3-120) M / 18ES3 / LT - 12VDC

8.

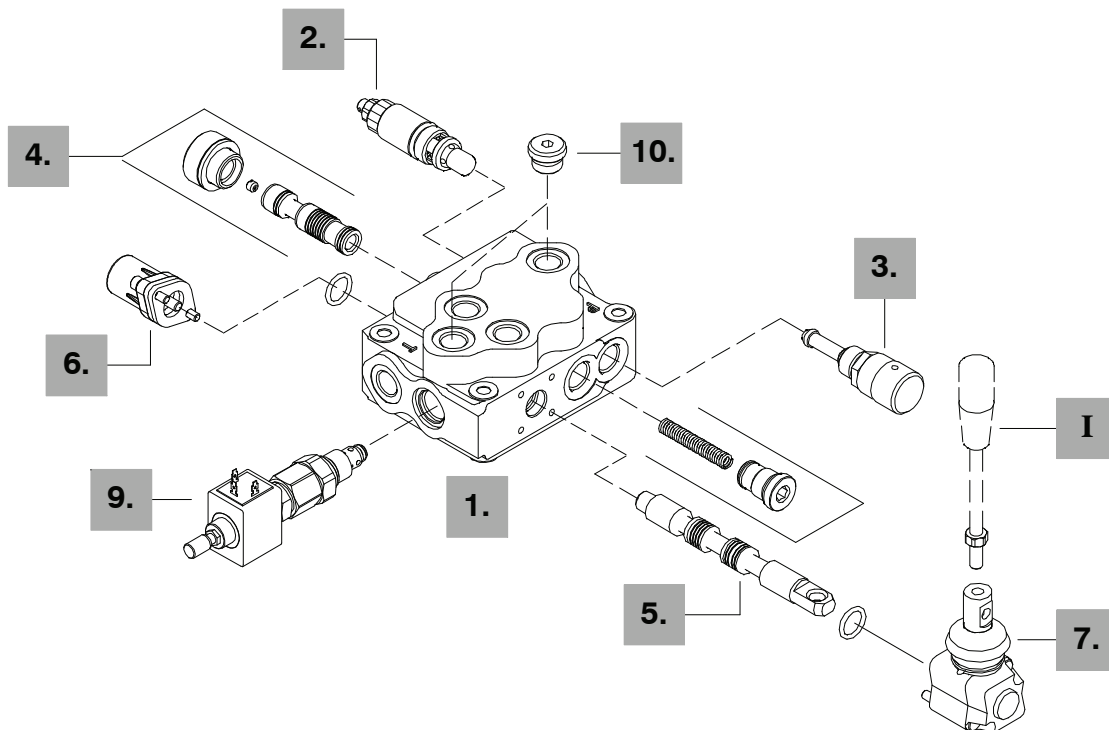

### 1. Body kit \*

TYPE	CODE	DESCRIPTION
1-P	5KC5013000	Parallel, 1 section

Include body and seals.

### 2. Inlet relief options

page 12

TYPE	CODE	DESCRIPTION
<u>VMD5 direct pressure relief valve type J</u>		
Standard setting is referred to 10 l/min flow.		
(JG2-63)	5KIT105412	Range 40 to 63 bar / 580 to 900 psi standard setting 63 bar / 900 psi
(JG3-120)	5KIT105413	Range 50 to 200 bar / 725 to 2900 psi standard setting 120 bar / 1750 psi
(JG4-220)	5KIT105414	Range 160 to 315 bar / 2300 to 4600 psi standard setting 220 bar / 3200 psi
SV	XTAP623282	Relief valve blanking plug

NOTE (\*) - Codes are referred to **BSP** threads.

**3. Flow controls** *page 124*

TYPE	CODE	DESCRIPTION
<b>M</b>	XCAR705211	Continuous fine wheel regulation
<b>G</b>	XCAR705202	Screw regulation with locking nut

**4. Compensator kit**

TYPE	CODE	DESCRIPTION
-	5CAS316065	Compensator kit

**5. Spool options** *page 125*

TYPE	CODE	DESCRIPTION
<b>1</b>	3CU1210730	Double acting, 3 positions, with A and B closed in neutral position
<b>2</b>	3CU1225730	Double acting, 3 positions, with A and B open to tank in neutral position
<u>Special spools for particular positioner kits</u> ..... <i>page 14</i>		
<b>5T</b>	3CU1243701	Double acting, 4 positions, floating circuit in 4 <sup>th</sup> position with spool out.

**6. "A" side spool positioners** *page 86*

TYPE	CODE	DESCRIPTION
<b>8</b>	5V08104000	With spring return in neutral position
<b>8D</b>	5V08104200	With spring return in neutral position and pin with M6 female thread for dual control
<b>8D2</b>	5V08104220	With spring return in neutral position and pin with M8 male thread for dual control
<b>8F2</b>	5V08104101	With spring return in neutral position and adjustable flow limiter
<b>19</b>	5V19104000	2 positions, with spring return in neutral position from position 1
<b>20</b>	5V19104000	2 positions, with spring return in neutral position from position 2
<b>9</b>	5V09104010	With detent in position 1 and spring return in neutral position
<b>10</b>	5V10104011	With detent in position 2 and spring return in neutral position
<b>11</b>	5V11104000	Detent in positions neutral, 1 and 2
<b>12</b>	5V12104000	Detent in positions 1 and 2
<b>15</b>	5V15104000	2 positions, detent in positions 1 and neutral
<b>16</b>	5V16104000	2 positions, detent in positions 2 and neutral
<b>9BZ</b>	5V09204010	With detent in position 1 and spring return in neutral position
<b>10BZ</b>	5V10204010	With detent in position 2 and spring return in neutral position
<b>11BZ</b>	5V11204010	Detent in positions 1 and 2 and spring return in neutral position
<b>8MG3</b>	5V08104660	With spring return in neutral position and microswitch in positions 1 and 2
<b>8P</b>	5V08104701	ON/OFF pneumatic kit
<b>8EP3</b>	5V08104735	ON/OFF 12 VDC electro-pneumatic kit
	5V08104740	ON/OFF 24 VDC electro-pneumatic kit
<b>8ED3</b>	5V08104350	ON/OFF 12 VDC electro-hydraulic kit
	5V08104351	ON/OFF 24 VDC electro-hydraulic kit
<u>Particular positioner kits for special spools</u> ..... <i>page 96</i>		
<b>13QN</b>	5V13404020	4 pos. with spring return in neutral pos. and detent in 4 <sup>th</sup> pos.: <b>for spool 5T</b>

**7. "B" side options** *page 39*

TYPE	CODE	DESCRIPTION
<b>L</b>	5LEV205000	Lever box for M10 handlever (for dimensions see LM10 for SD5 directional valve)
<b>SLP</b>	5COP105000	Without lever box, with dust-proof plate
<b>TQ</b>	5TEL105110	Flexible cable connection

**8. Complete controls** *page 46*

ON/OFF solenoid control type **8ES**.

**9. Solenoid pilot unloader valve** *page*

TYPE	CODE	DESCRIPTION
<b>EL-12VDC</b>	YCAR405305	With 12VDC electric control unloader valve; normally open circuit
<b>EL-24VDC</b>	YCAR405310	As previous 24VDC
<b>ELC-12VDC</b>	5CAR405330	With 12VDC electric control unloader valve; normally closed circuit
<b>ELC-24VDC</b>	5CAR405331	As previous 24VDC
<b>LT</b>	XTAP523370	Valve blanking plug

**10. Inlet and outlet selection \*** *page 79*

TYPE	CODE	DESCRIPTION
<b>PSL</b>	3XTAP722160	Side ports; need n.2 G 3/8 plugs, standard configuration (omit in valve description)
<b>PSA</b>	3XTAP722160	Upper ports; need n.2 G 3/8 plugs

**I Optional handlevers**

TYPE	CODE	DESCRIPTION
<b>AL01/M10x150</b>	170012015	For lever L: height 150 mm / 5.91 in

## Flow controls

Pressure compensated flow control with max. regulated flow = 45 l/min.

### Type M

Continuous fine wheel regulation

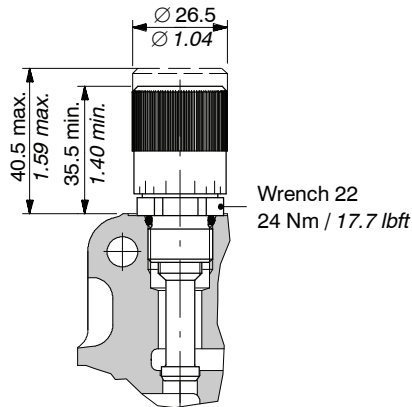

### Type G

Continuous screw regulation with locking nut.

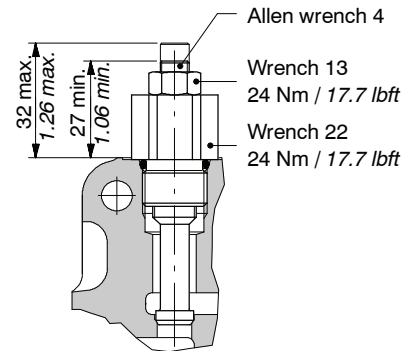

**Pressure-flow diagram**

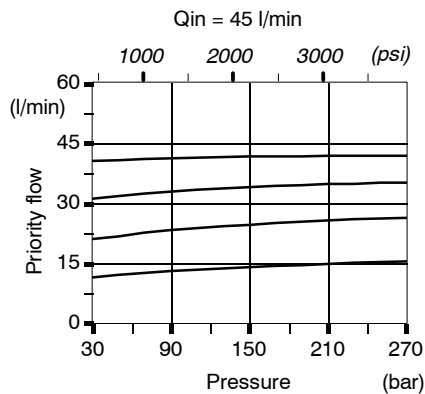

**Flow regulation diagram**

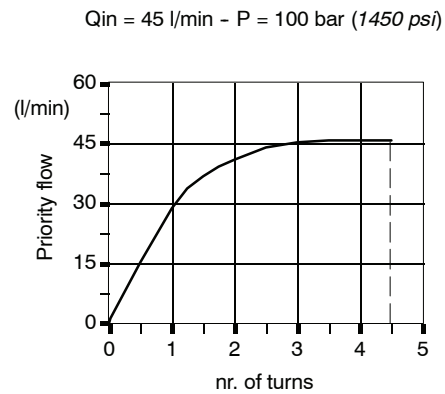

Type 1

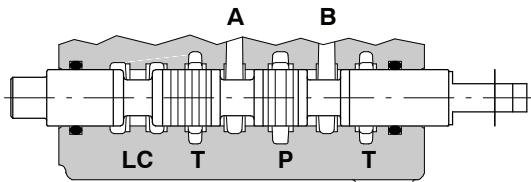

P-A-B-T closed, with flow through line (LC) open

+ 5,5 mm / 0.22 in  
 (1) ►  
 ◄ ► (0)  
 ◄ (2)  
 - 5,5 mm / 0.22 in

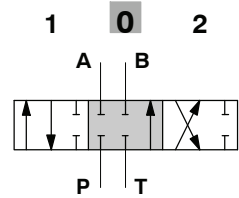

Type 2

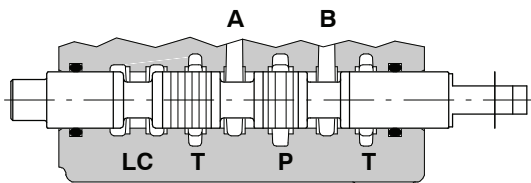

P closed, A-B→T, flow through line (LC) open

+ 5,5 mm / 0.22 in  
 (1) ►  
 ◄ ► (0)  
 ◄ (2)  
 - 5,5 mm / 0.22 in

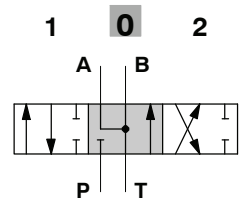

Type 5T

It needs special body with extra machining: for information please contact Sales Department.

This spool must be coupled with positioner type 13QN (see page 96).

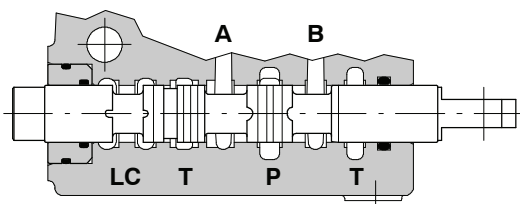

P-A-B-T closed, with flow through line (LC) open

+ 9 mm / 0.35 in  
 (3) ►►  
 (1) ► + 4.5 mm / 0.18 in  
 ◄ ► (0)  
 ◄ (2)  
 - 4.5 mm / 0.18 in

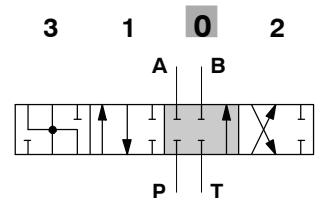

## Installation and maintenance

The SD5 valve is assembled and tested as per the technical specification of this catalogue.

Before the final installation on your equipment, follow the below recommendations:

- the valve can be assembled in any position, in order to prevent body deformation and spool sticking mount the product on a flat surface;
- in order to prevent the possibility of water entering the lever box and spool control kit, do not use high pressure wash down directly on the valve;
- prior to painting, ensure plastic port plugs are tightly in place.

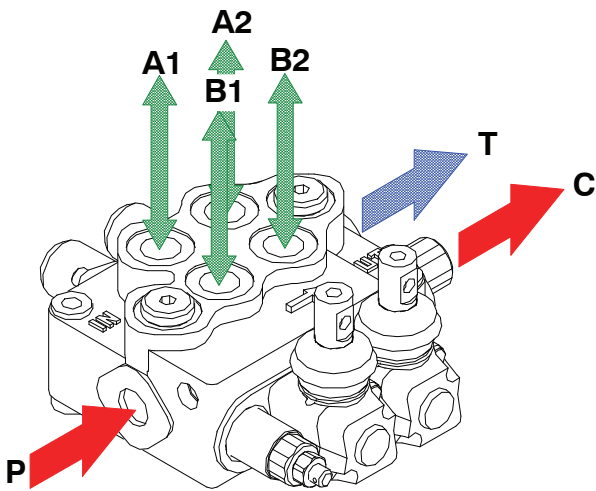

**SD5 directional valve with carry-over configuration**

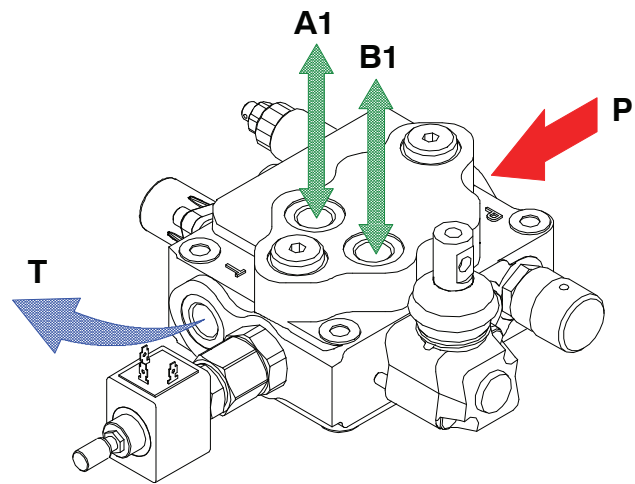

**SDM105 directional valve**

### Fittings tightening torque - Nm / lbft

THREADS TYPE	P and C ports	A and B ports	T port
BSP (ISO 228/1)	G 3/8	G 3/8	G 3/8 (G 1/2*)
With O-Ring seal	35 / 25.8	35 / 25.8	35 / 25.8 (50 / 36.9*)
With copper washer	40 / 29.5	40 / 29.5	40 / 29.5 (50 / 36.9*)
With steel and rubber washer	30 / 22.1	30 / 22.1	30 / 22.1 (50 / 36.9*)
UN-UNF (ISO 11926-1)	3/4-16 UNF-2B (SAE 8)	9/16-18 UNF-2B (SAE 6)	3/4-16 UNF-2B (SAE 8)
With O-Ring seal	40 / 29.5	30 / 22.1	30 / 22.1
METRIC (ISO 262)	M18 x 1.5	M18 x 1.5	M18 x 1.5 (M22x1.5*)
With O-Ring seal	35 / 25.8	35 / 25.8	35 / 25.8 (50*)
With copper washer	40 / 29.5	40 / 29.5	40 / 29.5 (50*)
With steel and rubber washer	40 / 29.5	40 / 29.5	40 / 29.5 (50*)

(\*) - Only for series circuit.

NOTE - These torque are recommended. Assembly tightening torque depends on many factors, including lubrication, coating and surface finish. The manufacturer shall be consulted.

## SD5 directional control valve

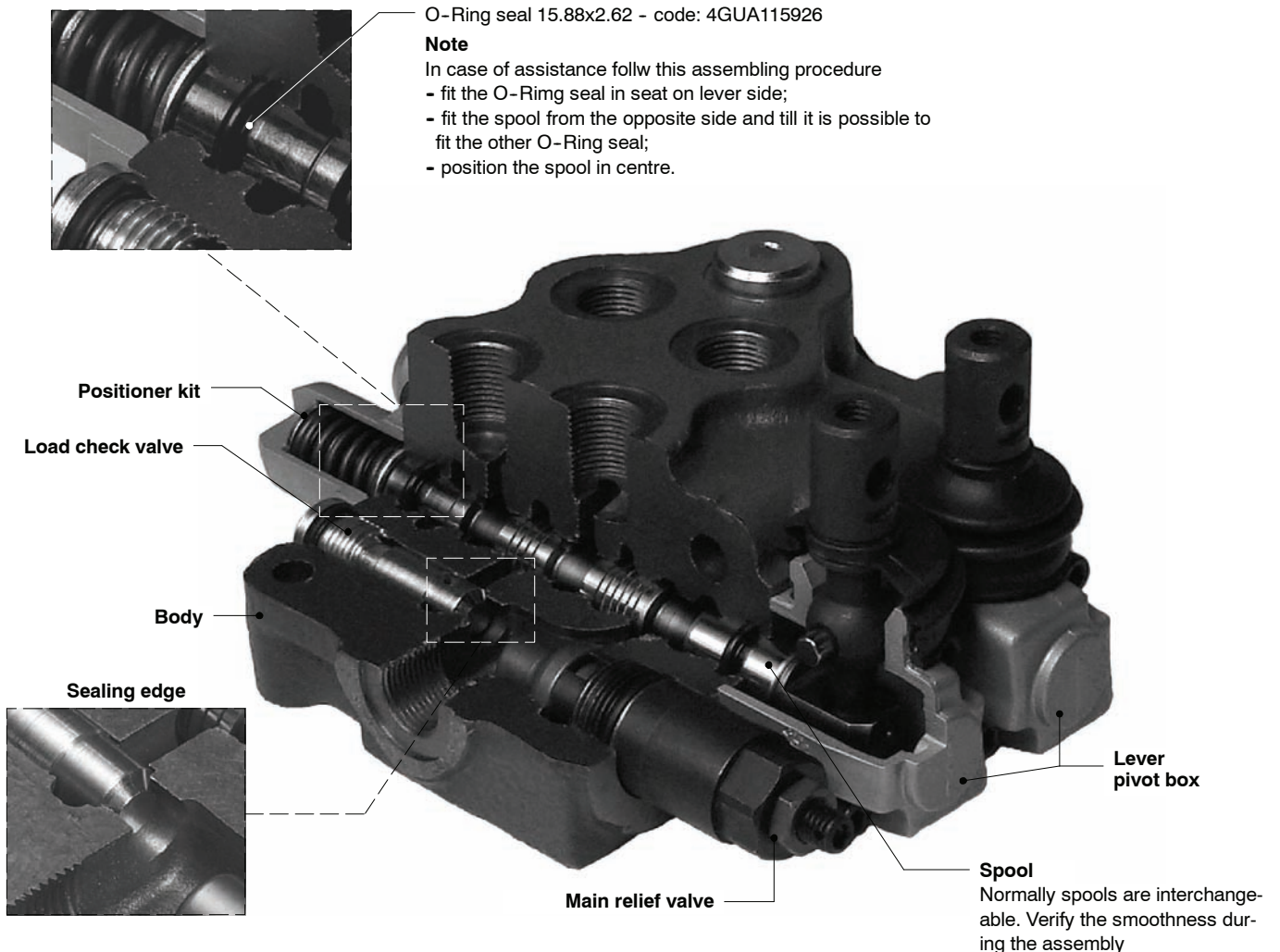

NOTE - All articulated parts inside cap, lever box and mechanical joystick are lubricated with synthetic base grease grade NLGI2

Malfunction	Cause	Remedy
External leakage pivot box lever or control kit side.	Worn spool seal due to mechanical actuation or high back pressure.	Locate the leakage and replace the seal. Check back pressure level.
Excessive internal leakage on A and B ports.	Increase clearance between spools and body due to high wear.	Replace the directional control valve and check the oil contamination level.
Dropping load during transition while raising	High leakage on the load check valve.	Remove the load check valve and clean the seat, verifying it's not dented.
Inability to build pressure on A and B ports.	Pressure relief valve blocked open. Low pump pressure and flow.	Remove and clean or replace the valve. Check the pump and circuit.



### SDM105 directional control valve

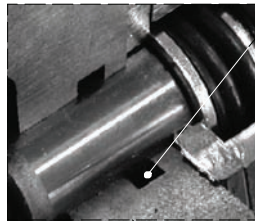

O-Ring seal 15.88x2.62 - code: 4GUA115926

**Note**

In case of assistance follow this assembling procedure

- fit the O-Ring seal in seat on lever side;
- fit the spool from the opposite side and till it is possible to fit the other O-Ring seal;
- position the spool in centre.

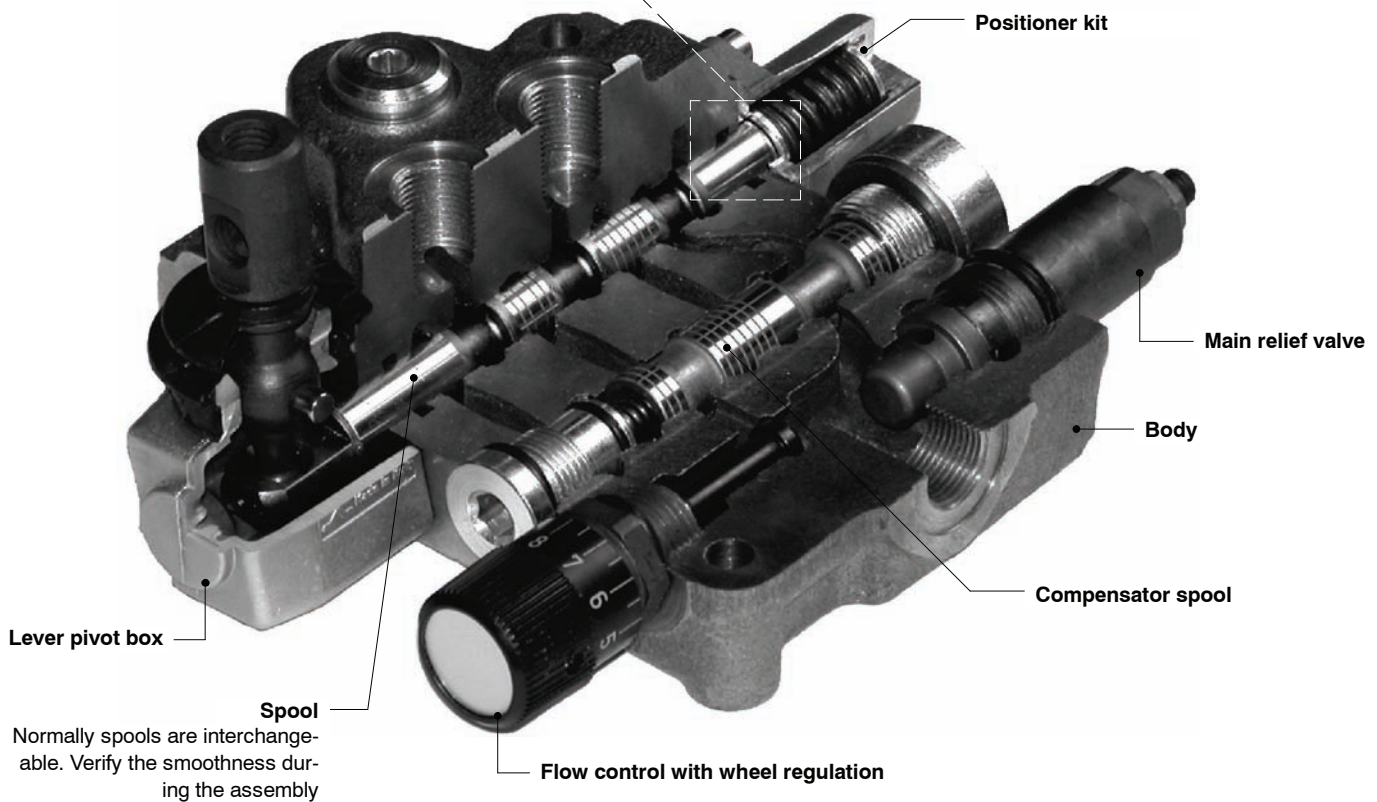

NOTE - All articulated parts inside cap, lever box and mechanical joystick are lubricated with synthetic base grease grade NLGI2

Malfunction	Cause	Remedy
External leakage pivot box lever or control kit side.	Worn spool seal due to mechanical actuation or high back pressure.	Locate the leakage and replace the seal. Check back pressure level.
Excessive internal leakage on A and B ports.	Increase clearance between spools and body due to high wear.	Replace the directional control valve and check the oil contamination level.
	Pressure relief valve blocked open.	Remove and clean or replace the valve.
Inability to build pressure on A and B ports.	Low pump pressure and flow.	Check the pump and circuit.
	Compensator spool is jammed.	Substitute the compensator spool and verify the smoothness during assembly. Check the oil contamination level.
The flow doesn't vary at the working ports by operating the flow regulator.	Control device of flow regulator is damaged.	Substitute the flow regulator.



## Connectors

**Type C01 code: 2X1001020**

2P+T, according to EN175301-803

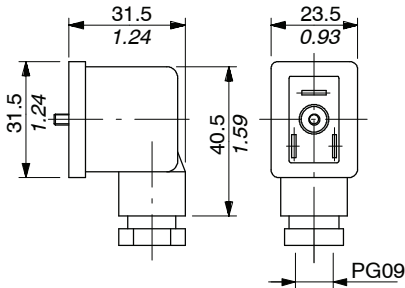
**Type C02 code: 2X1001010**

2P+T according to ISO4400 / EN175301-803

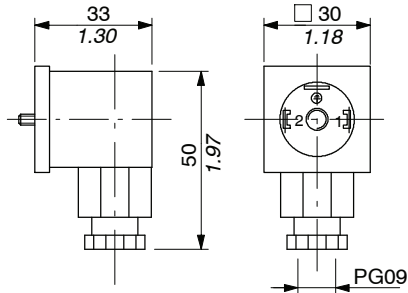
**Type C03 code: 2X1001030**

3P+T according to ISO4400 / EN175301-803

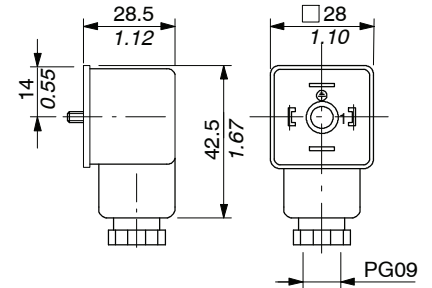
**Type C05 code: 2X1001080**

3P+T according to ISO4400 / EN175301-803.

With bridge rectifier, to use with VAC supply.

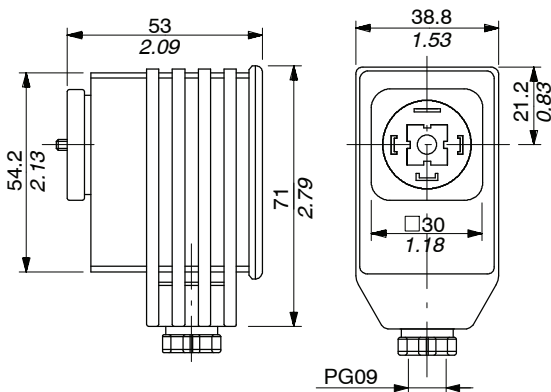
**Type C07 code: 5CON001**

2 poles, type Packard "Weather Pack" male housing with female ends

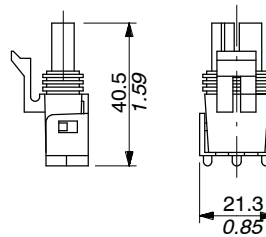
**Type C08 code: 5CON003**

2 poles, type AMP "Junior-Power-Timer" female housing with female ends

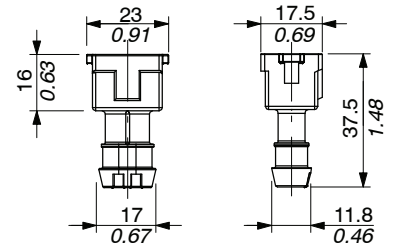
**Type C11 code: 5CON006**

4 poles according to VDE0660-0110

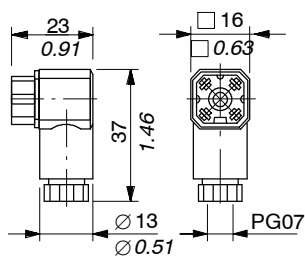
**Type C17 code: 5CON005**

2 poles, type Packard "Weather Pack" female housing with male ends

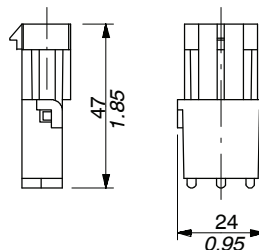
**Type C19 code: 5CON007**

2 poles, type "Deutsch DT06-2S" male housing with female ends

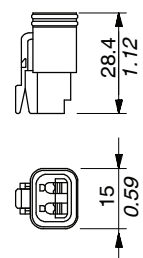

## Accessories

### Connectors

#### Type C20 code: 5CON017

2 pole, type "PACKARD Metri-Pack" male housing with female ends

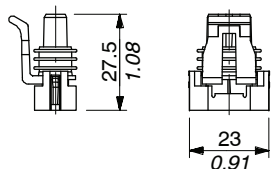

#### Type C21 code: 5CON018

2 poles, type "AMP Fastin-Faston" female housing with male ends

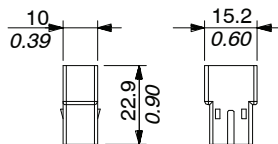

#### Type C24 code: 5CON0031

2 poles, type "AMP Superseal" male housing with female ends

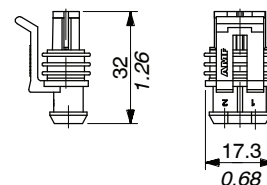

Type	Poles	Nominal voltage	Nominal current	Permitted conductor section range	Permitted cable diameter range	Weather protection
C01	2P + T	250 VAC / 300 VDC	10 A	max.1.5 mm <sup>2</sup> / max.0.0023 in <sup>2</sup>	6 to 8 mm / 0.24 to 0.31 in	IP65
C02	2P + T	250 VAC / 300 VDC	10 A	max.1.5 mm <sup>2</sup> / max.0.0023 in <sup>2</sup>	6 to 8 mm / 0.24 to 0.31 in	IP65
C03	3P + T	250 VAC / 300 VDC	10 A	max.1.5 mm <sup>2</sup> / max.0.0023 in <sup>2</sup>	6 to 8 mm / 0.24 to 0.31 in	IP65
C05	3P + T	230 VAC	1.5 A	max.1.5 mm <sup>2</sup> / max.0.0023 in <sup>2</sup>	6 to 8 mm / 0.24 to 0.31 in	IP65
C06	3P + T	250 VAC / 300 VDC	6 A	max.0.75 mm <sup>2</sup> / max.0.00116 in <sup>2</sup>	3.5 to 6 mm / 0.14 to 0.24 in	IP65
C07	2P	/	20 A	1 to 2 mm <sup>2</sup> / 0.00155 to 0.0031 in <sup>2</sup>	2.8 to 3.5 mm / 0.11 to 0.14 in	IP67
C08	2P	250 VAC	12 A	0.5 to 1 mm <sup>2</sup> / 0.00077 to 0.00155 in <sup>2</sup>	1.3 to 1.6 mm / 0.05 to 0.063 in	IP65
C11	4P	50 VAC / 120 VDC	6 A	0.14 to 0.5 mm <sup>2</sup> / 0.00022 to 0.00077 in <sup>2</sup>	4 to 7.5 mm / 0.16 to 0.29 in	IP65
C17	2P	/	20 A	1 to 2 mm <sup>2</sup> / 0.00155 to 0.0031 in <sup>2</sup>	1.3 to 1.4 mm / 0.05 to 0.067 in	IP67
C19	2P	/	13 A	1 to 1.2 mm <sup>2</sup> / 0.00155 to 0.00186 in <sup>2</sup>	2.2 to 3.5 mm / 0.088 to 0.14 in	IP67
C20	2P	/	14 A	0.8 to 1 mm <sup>2</sup> / 0.00124 to 0.00155 in <sup>2</sup>	1.3 to 1.7 mm / 0.05 to 0.067 in	/
C21	2P	/	7A	0.3 to 0.8 mm <sup>2</sup> / 0.00046 to 0.0012 in <sup>2</sup>	2.2 to 3 mm / 0.087 to 0.118 in	/
C24	2P	/	14 A	0.3 to 5 mm <sup>2</sup> / 0.00046 to 0.00077 in <sup>2</sup>	1.4 to 1.7 mm / 0.055 to 0.067 in	IP67

## Notes

SD5 valve can be supplied with one coat of black paint (**CVN** configuration).

Description example: SD5/2-P(JG3-120)/18L/18L/AET-<**CVN**>

NOTE - For different colour consult Sales Department.

## DIMENSIONE "A"

Tipo valvola	(mm)
ELN(NA)	67
ELP(NA)	90,5
ELT(NA)	92,5
ELN(NC)	63

