

DPS2-20 - Logic element

Differential pressure sense valves
303 L/min (80 USgpm) • 210, 350 bar (3000, 5000 psi)

Functional symbols

See pages I-142 & I-143

Operation

This valve is used as a main section of a pilot controlled valve assembly. This valve has multiple uses when used with either directional control, flow control or pressure control cartridges. Refer to application examples.

Features

Hardened and ground and honed working components. Cartridge construction for maximum mounting flexibility. Low leakage with poppet valves and 350 bar pressure rating.

Sectional view

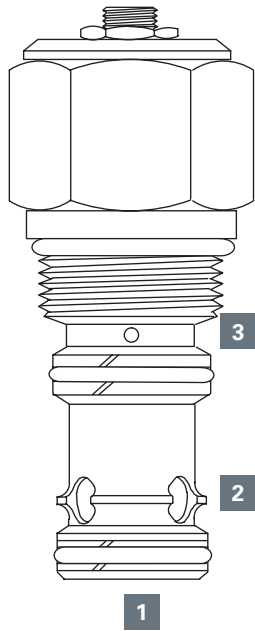

Performance data

Ratings and specifications

Performance data is typical with fluid at 21,8 cSt (105 SUS) and 49° C (120° F)

Typical application pressure	Spool type: 290 bar (4200 psi) Poppet type: 210 bar (3000 psi) or 350 bar (5000 psi)
Rated flow	303 L/min (80 USgpm)
Pilot ratio	Spool type P, V, R, F: 1:1
Internal leakage	Poppet type B, S, T: 2:1
Temperature range	Spool type: 82 cm ³ /min. (5 in ³ /min) max @ 290 bar (4200 psi) Poppet type: Port 1 to 2: < 5 drops/min max @ 350 bar (5000 psi)
Cavity	-40° to 120° C (-40° to 248° F)
Standard housing materials	C-20-3S
Fluids	Aluminium
Filtration	All general purpose hydraulics fluids such as: MIL-H-5606, SAE 10, SAE 20 etc
Weight cartridge only	Cleanliness code 18/16/13
Seal kit	0,81 kg (1.78 lbs) 02-113153 (Buna-N), 02-112969 (Viton®)

Viton is a registered trademark of E.I. DuPont

Description

These are normally open or closed logic elements with or without a control orifice. They can be used as main valves for the control of high flows using small pilot cartridges, as compensators or load sense elements.

Pressure drop curve

Cartridge only

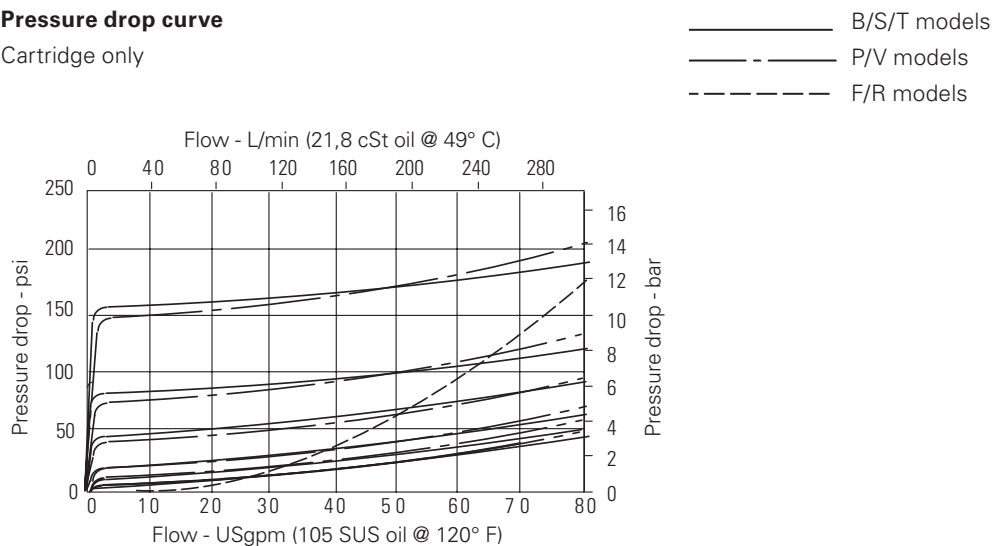

Where measurements are critical request certified drawings. We reserve the right to change specifications without notice.

DPS2-20 - Logic element

Differential pressure sense valves
303 L/min (80 USgpm) • 210, 350 bar (3000, 5000 psi)

Model code

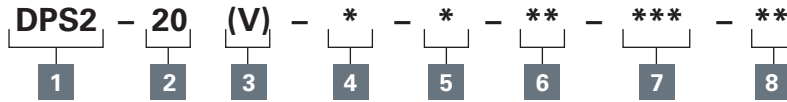

1 Function

DPS2 - Differential pressure sensing

Size

20 - 20 size

3 Seal material

Blank - Buna-N
V - Viton®

4 Function

B - Poppet, vent to open, N/C
S - Poppet, vent to open, N/C
T - Poppet, bi-directional, pilot to close, 2:1 ratio, N/C
P - Spool, N/C (L/S element)
V - Spool, N/C

R - Spool, pressure reducing, N/O

F - Spool, flow control, N/O (hydrostat)

5 Port size

0 - Cartridge only

Code	Port size	Housing number
		Aluminium
8B	1" BSPP	02-175472*
16T	SAE 16	566415*
12H	SAE 12	876741
16H	SAE 16	876743
6G	3/4" BSPP	876740
8G	1" BSPP	876742

* Light duty housing
See section J for housing details.

6 Stroke adjustment

F - None (Fixed stroke)
S - Screw adjustment

Screw adjustment is not available with F and R functions.

7 Differential pressure

Note: Code based on pressure in psi

005 - 0,35 bar (5 psi)+*

10 - 0,7 bar (10 psi)+*

20 - 1,40 bar (20 psi)+*

40 - 2,80 bar (40 psi)

80 - 5,50 bar (80 psi)

160 - 11,0 bar (160 psi)

+ Not available with the "B", "S" and "T" poppet.

* The operating back pressure at port 3 should never be less than 1.3 times the spring set pressure.

8 Special features

00 - 210 bar (3000 psi) rated valve

AA - 350 bar (5000 psi) rated valve (poppet type only).

(Only required if valve has special features, omit if "00".)

Dimensions

mm (inch)

Cartridge only

Torque cartridge in housing

A - 128-155 Nm (95-115 ft lbs)

S - 163-183 Nm (120-135 ft lbs)

Note: For application at 350 bar (5000 psi) torque into steel housing to 205-218 Nm (150-160 ft. lbs) (for valves with "AA" special feature only).

Installation drawing

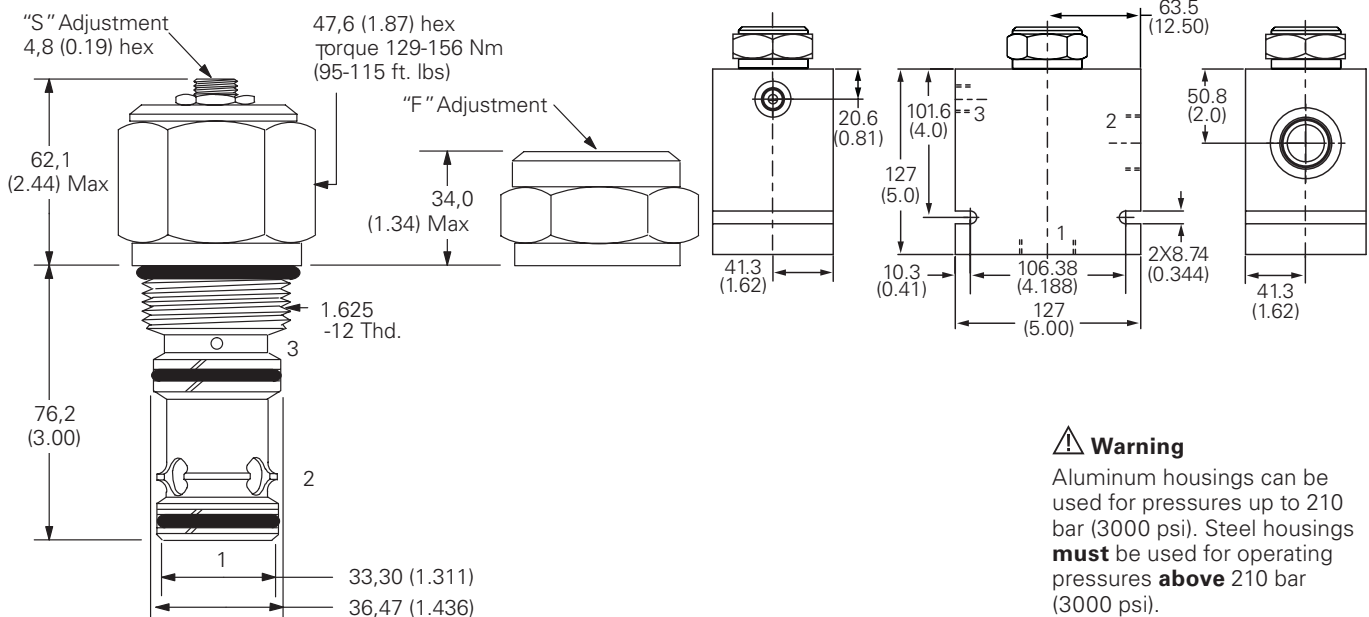

Warning

Aluminum housings can be used for pressures up to 210 bar (3000 psi). Steel housings **must** be used for operating pressures **above** 210 bar (3000 psi).

Where measurements are critical request certified drawings. We reserve the right to change specifications without notice.

DPS2

Spool type functional symbols

DPS2-**-P-S

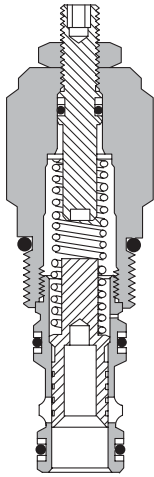
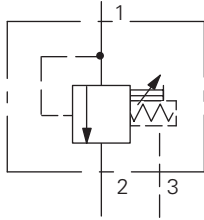

DPS2-**-P-F

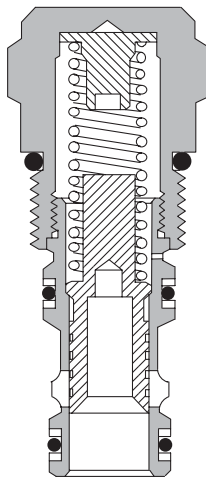
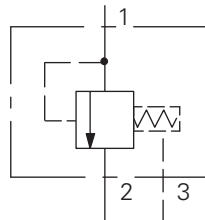

DPS2-**-V-S

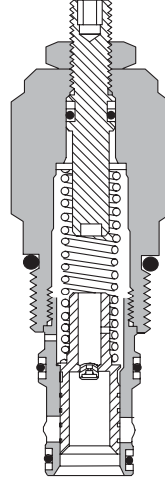
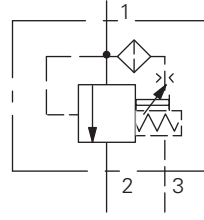

DPS2-**-V-F

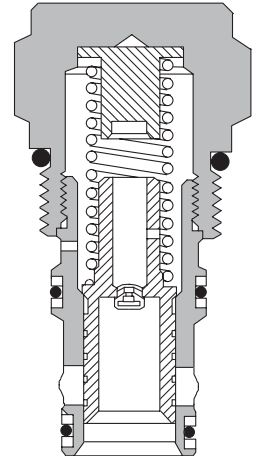
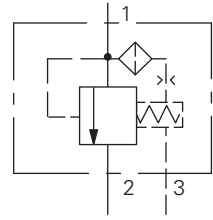

DPS2-**-F-F

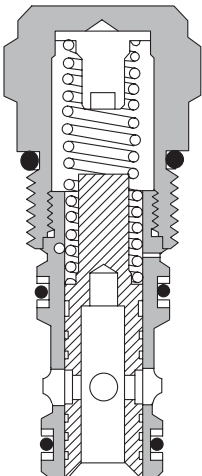
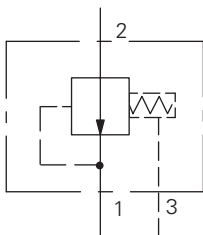

DPS2-**-R-F

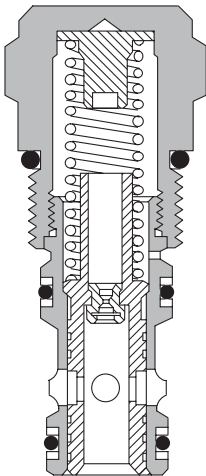
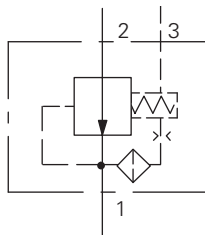

Where measurements are critical request certified drawings. We reserve the right to change specifications without notice.

DPS2-**-B-S

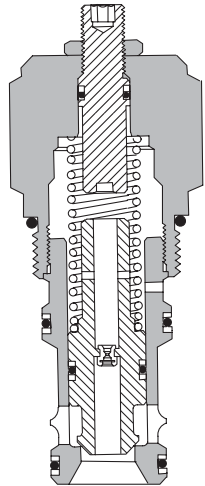
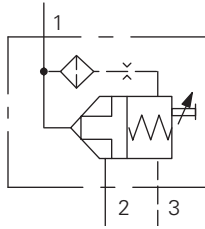

DPS2-**-B-F

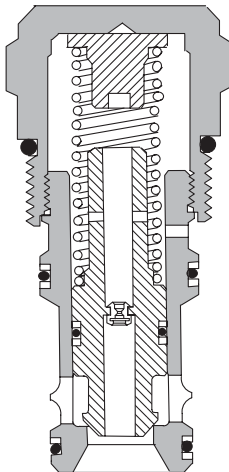
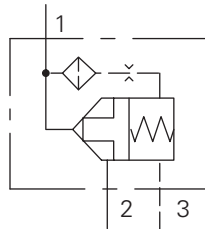

DPS2-**-S-S

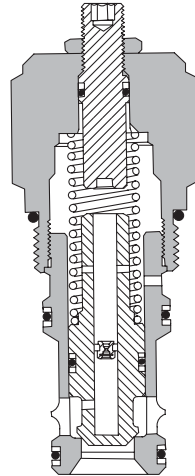
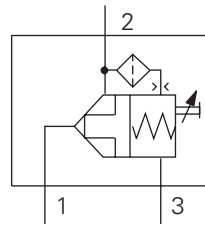

DPS2-**-S-F

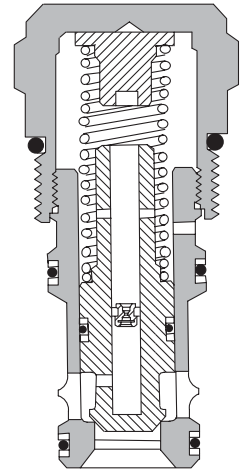
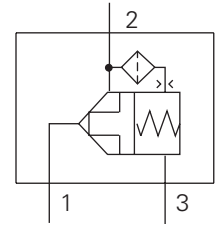

DPS2-**-T-S

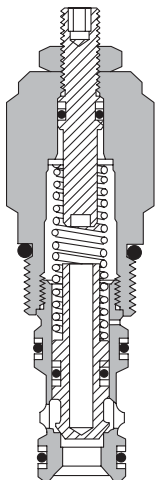
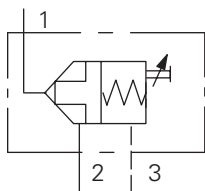

DPS2-**-T-F

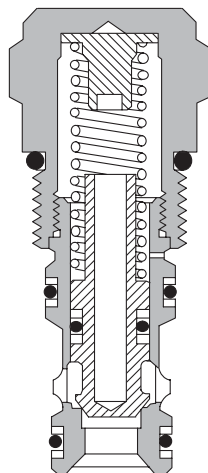
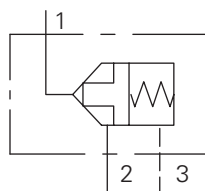

Where measurements are critical request certified drawings. We reserve the right to change specifications without notice.