

CV3-10/CV13-10 - Check Valve

Direct acting, poppet type

Up to 76 L/min (20 USgpm) • 350 bar (5000 psi)

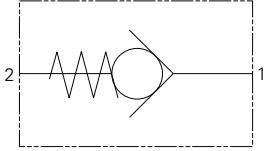

Operation

The valve remains closed until the spring bias is reached at port 1 at which time the poppet lifts off the seat and allows flow from port 1 to port 2. In the other direction the valve is closed.

Features

Hardened and ground working parts to limit leakage and extend service life.

Sectional View

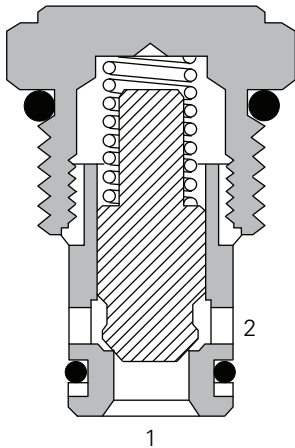

Performance Data

Ratings and Specifications

Performance data is typical with fluid at 21,8 cSt (105 SUS) and 49°C (120°F)

Typical application pressure (all ports) CV3/CV13	210 bar (3000 psi)/350 bar (5000 psi)
Cartridge fatigue pressure (infinite life) CV3/CV13	210 bar (3000 psi)/350 bar (5000 psi)
Rated flow	76 L/min (20 USgpm)
Free flow cracking pressures @ 1.0 L/min (0.25 USgpm)	003 - 0.21 bar (3 psi) 010 - 0.69 bar (10 psi) 020 - 1.38 bar (20 psi) 035 - 2.41 bar (35 psi) 040 - 2.76 bar (40 psi) 065 - 4.48 bar (65 psi) 100 - 6.90 bar (100 psi) 180 - 12.40 bar (180 psi) 210 - 14.50 bar (210 psi)
Internal leakage, Port 2 to 1	5 drops/min. maximum @ 350 bar (5000 psi)
Temperature range	-40° to 120°C (-40° to 248° F)
Cavity	C-10-2
Fluids	All general purpose hydraulic fluids such as MIL - H-5606, SAE 10, SAE 20, etc.
Filtration	Cleanliness code 18/16/13
Standard housing material	Aluminum or steel
Weight: cartridge only	0.08 kg (0.17 lbs.)
Seal kit	565803 (Buna-N) 566086 (Viton®)

Viton is a registered trademark of E.I. DuPont

Description

This is a compact poppet type check valve ideal for use in manifolds for load sense or low flow applications.

Pressure Drop

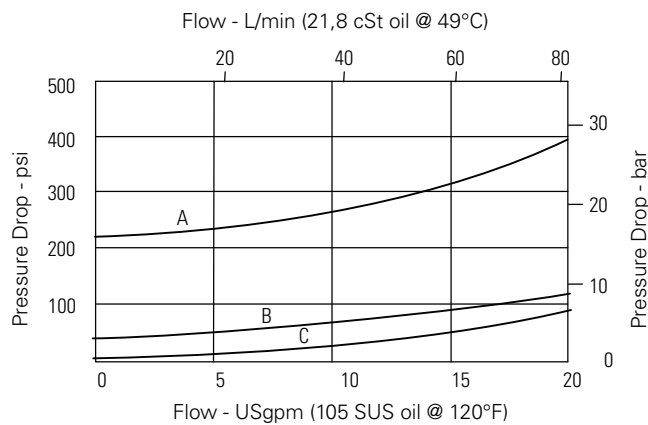

A – CV(*)3 10*P 000 210 00

C – CV(*)3 10*P 000 003 00

B – CV(*)3 10*P 000 040 00

Where measurements are critical request certified drawings. We reserve the right to change specifications without notice.

CV3-10/CV13-10 - Check Valve

Direct acting, poppet type
Up to 76 L/min (20 USgpm) • 350 bar (5000 psi)

Model Code

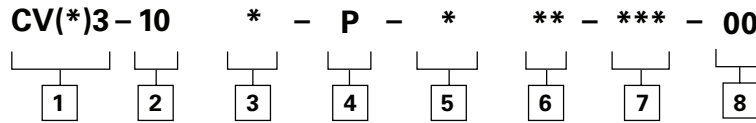

1 Function

CV3 - Check valve 210 bar (3000 psi)
CV13 - Check valve 350 bar (5000 psi)

2 Size

10 - 10 size

3 Seal Material

N - Buna-N
V - Viton

4 Style

P - Poppet

5 Valve Housing Material

0 - None
A - Aluminum
S - Steel

6 Port Size

Code	Port Size	Housing Number		
		Aluminum Light Duty	Aluminum Fatigue Rated	Steel Fatigue Rated
00	Cartridge only			
3B	3/8" BSPP	02-175462	-	-
6T	SAE 6	566151	-	02-175100
8T	SAE 8	-	-	02-175101
2G	1/4" BSPP	-	876702	02-175102
3G	3/8" BSPP	-	876703	02-175103
6H	SAE 6	-	876700	-
8H	SAE 8	-	876701	-

See section J for housing details.

7 Free Flow Cracking Pressure

003 - 0.21 bar (3 psi) (anticavitation)
010 - 0.69 bar (10 psi) (anticavitation)
020 - 1.38 bar (20 psi)
035 - 2.41 bar (35 psi)
040 - 2.76 bar (40 psi)
065 - 4.48 bar (65 psi)
100 - 6.90 bar (100 psi)
180 - 12.4 bar (180 psi)
210 - 14.5 bar (210 psi)

8 Special Features

00 - None (Only required if valve has special features, omitted if "00")
SS - 316 Stainless Steel external components

Dimensions

mm (inch)

Cartridge Only

Basic Code
CV3-10

Torque cartridge in aluminum housing 47-54 Nm (35-40 ft. lbs). Torque cartridge in steel housing 68-70 Nm (50-55 ft. lbs)

A - 108-122 Nm (80-90 ft. lbs)

S - 136-149 Nm (100-110 ft. lbs).

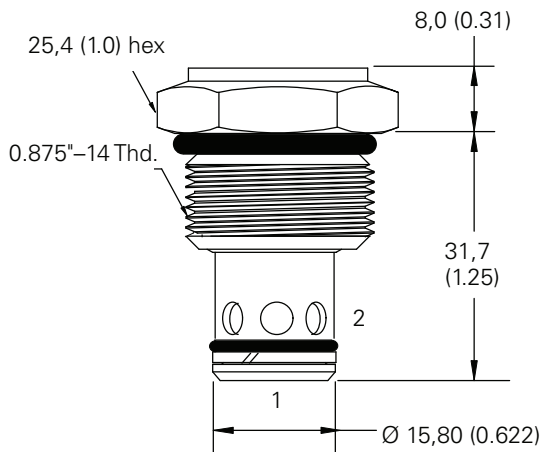

Installation Drawing (Steel)

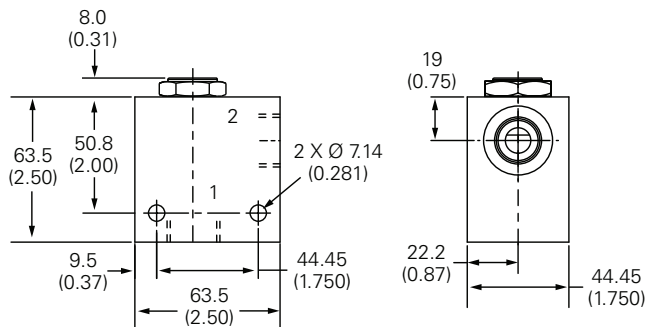

WARNING

Aluminum housings can be used for pressures up to 210 bar (3000 psi). Steel housings must be used for operating pressures above 210 bar (3000 psi).