

BS5... SINGLE STATION SUBPLATE



CETOP 5 SUBPLATES

BS501 / BS50	CAP. VII • 19
BS512... / BS513...	
BS514... / BS515...	CAP. VII • 20
BS516... / BS517...	
BS53...	CAP. VII • 21
BS530/31...	CAP. VII • 22
BSVMP20... / BS529...	CAP. VII • 23
BC536/28...	CAP. VII • 24
BC541/*... / BC540...	CAP. VII • 25
BC530/32... / BC550...	
BC551...	CAP. VII • 26
BC507... / BC5107...	
BC53A... / BC1006...	CAP. VII • 27
BM5**... / BM550...	CAP. VII • 28
BM560... / BM570...	
BM580...	CAP. VII • 29
CMP20...	CARTRIDGE CATALOGUE
CMP30...	CARTRIDGE CATALOGUE

BS501...

- BS** Single subplate (blanking)
- 5** CETOP 5/NG10
- 01** P/T/A/B closed
- 00** No variant
- 1** Serial No.

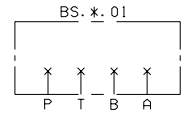

• Pay attention please, use these subplate in applications at slow pressure (P max. 150 bar dynamic)

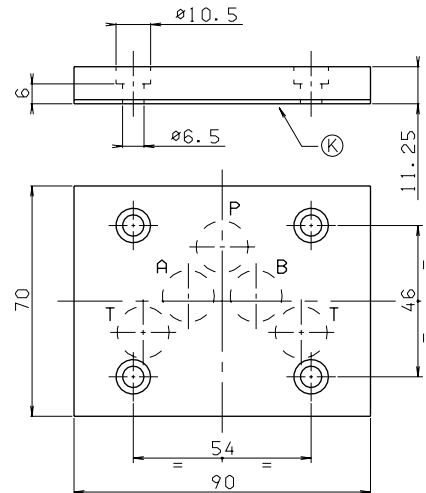

Weight: 0,5 Kg

Fixing screws
M6x15 UNI 5931
K = plate OR (Q25950002)

BS5...

- BS** Single subplate (blanking)
- 5** CETOP 5/NG10
- **** 02/03/04/05/06/07/08/09
- 00** No variant
- 1** Serial No.

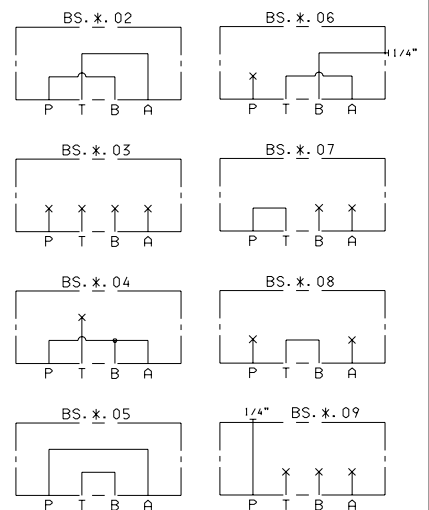
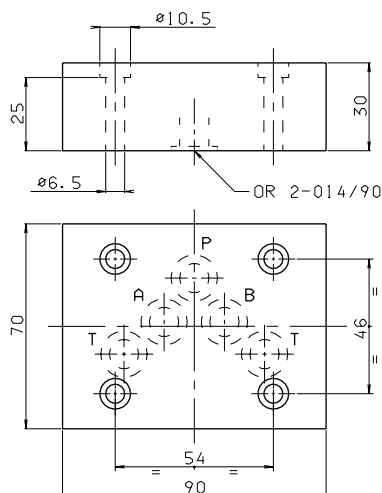

Weight: 1,2 Kg

Fixing screws M6x35 UNI 5931

BS5... SINGLE STATION SUBPLATE

BS512 (REAR CONNECTORS)

- BS** Single subplate
- 5** CETOP 5/NG10
- 12** 1/2" BSP rear connectors
- 00** No variant
- 1** Serial No.

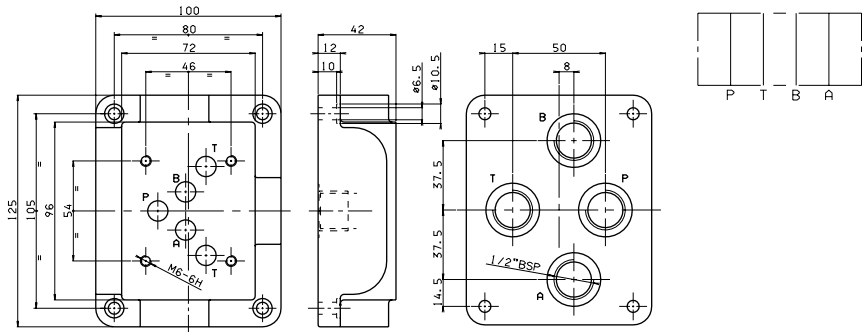

Weight: 2,7 Kg - Fixing screws M6x25 UNI 5931

BS513 (REAR CONNECTORS)

- BS** Single subplate
- 5** CETOP 5/NG10
- 13** 3/4" BSP rear connectors
- 00** No variant
- 1** Serial No.

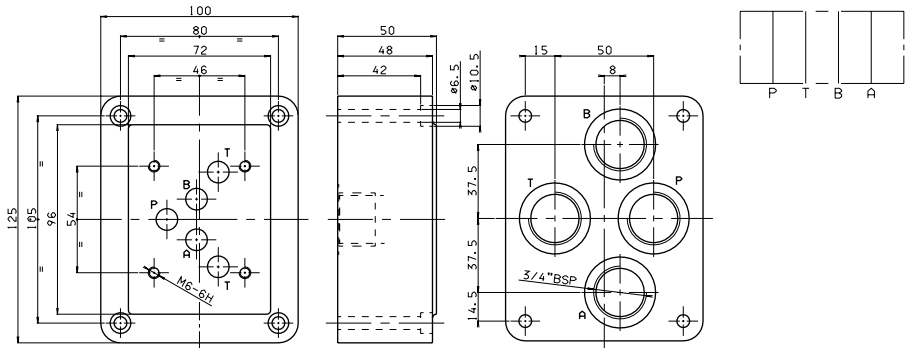

Weight: 3,8 Kg - Fixing screws M6x50 UNI 5931

BS514 (SIDE CONNECTORS)

- BS** Single subplate
- 5** CETOP 5/NG10
- 14** 1/2" BSP side connectors
- 00** No variant
- 1** Serial No.

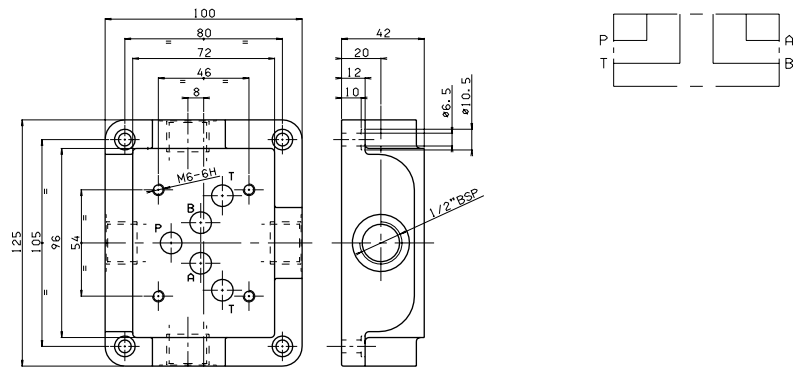

Weight: 2,6 Kg - Fixing screws M6x20 UNI 5931

BS515 (SIDE CONNECTORS)

- BS** Single subplate
- 5** CETOP 5/NG10
- 15** 3/4" BSP side connectors
- 00** No variant
- 1** Serial No.

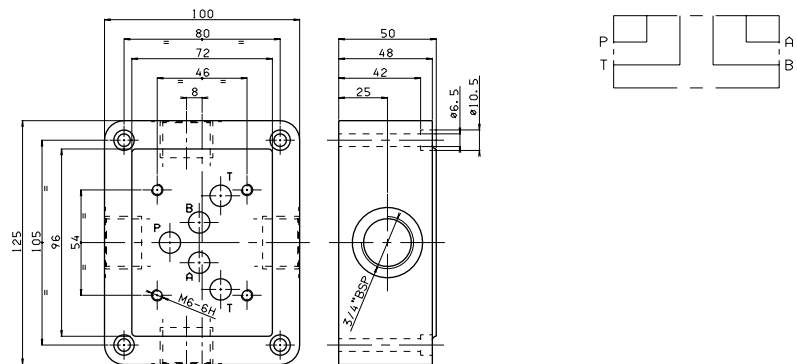

Weight: 3,8 Kg - Fixing screws M6x50 UNI 5931

BS5... SINGLE STATION SUBPLATE

BS516 (CONNECTORS SIDE A AND B, REAR P AND T)

- BS** Single subplate
- 5** CETOP 5/NG10
- 16** 1/2" BSP rear and side connectors
- 00** No variant
- 1** Serial No.

Weight: 2,6 Kg

Fixing screws M6x20 UNI 5931

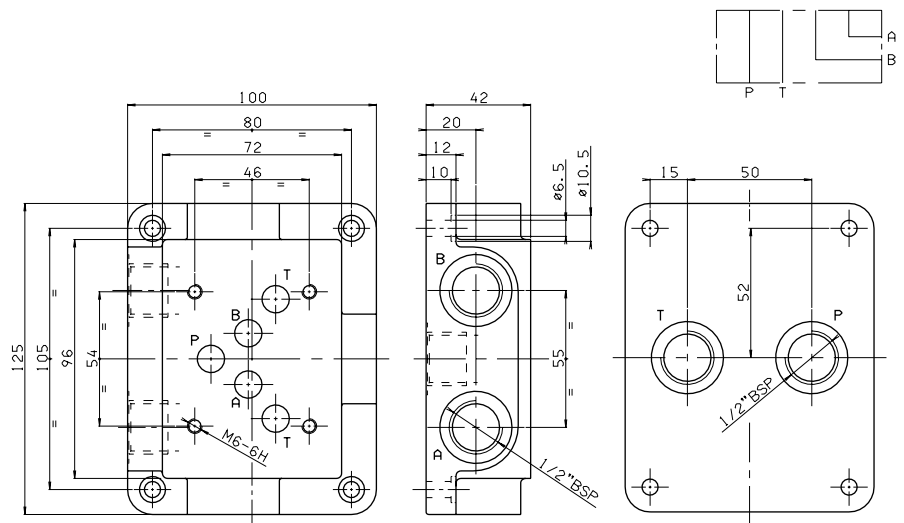

BS517 (CONNECTORS SIDE A AND B, REAR P AND T)

- BS** Single subplate
- 5** CETOP 5/NG10
- 17** 3/4" BSP rear and side connectors
- 00** No variant
- 1** Serial No.

Weight: 3,9 Kg

Fixing screws M6x50 UNI 5931

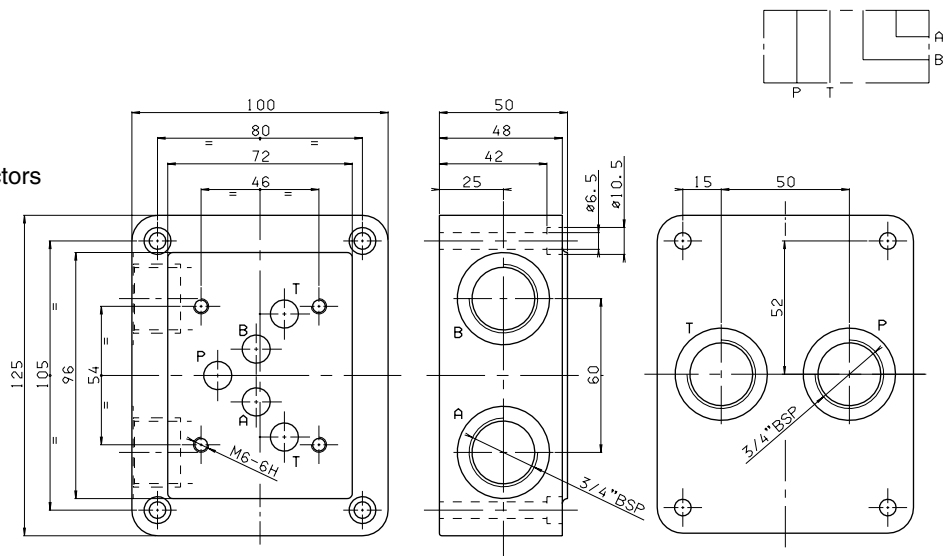

BS53 (REDUCTION PLATE FROM CETOP 5/NG10 TO CETOP 3/NG6)

- BS** Single subplate
- 5** CETOP 5/NG10
- 3** CETOP 3/NG6
- 00** No variant
- 1** Serial No.

Weight: 1,1 Kg

Fixing screws M6x30 UNI 5931

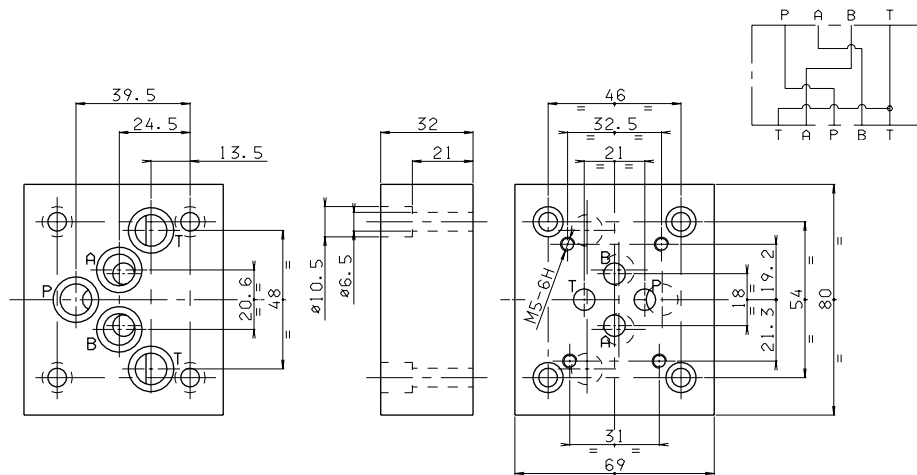

BS5... SINGLE STATION SUBPLATE

BS530/31

BS

Single subplate

5

CETOP 5/NG10

30 = Connectors A and B side, P and T rear (all 3/4" BSP)

31 = Connectors A and B side, P and T rear (all 3/4" BSP)

M = Plastic knob

C = Grub screw

Setting range

1 = max. 50 bar (**white spring**)

2 = max. 140 bar (**yellow spring**)

3 = max. 350 bar (**green spring**)

00

No variant

1

Serial No.

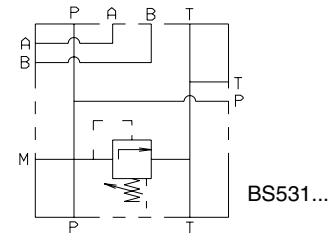
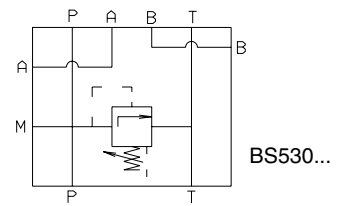

• The minimum permissible setting pressure depending on the spring:
see cartridge valve type CMP30...

BS530 (CONNECTORS A AND B SIDE, P AND T REAR)

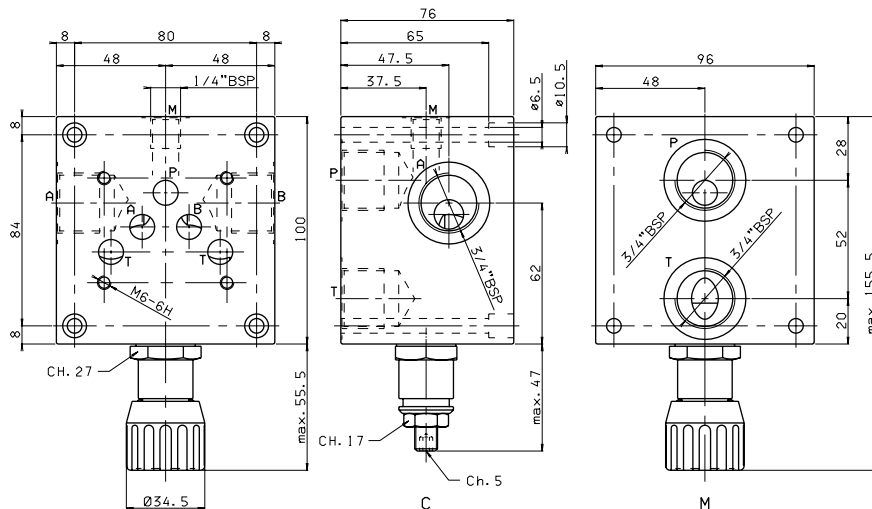

Weight: 5,5 Kg
Fixing screws
M6x75 UNI 5931

BS5.1 (CONNECTORS A AND B SIDE, P AND T SIDE AND REAR)

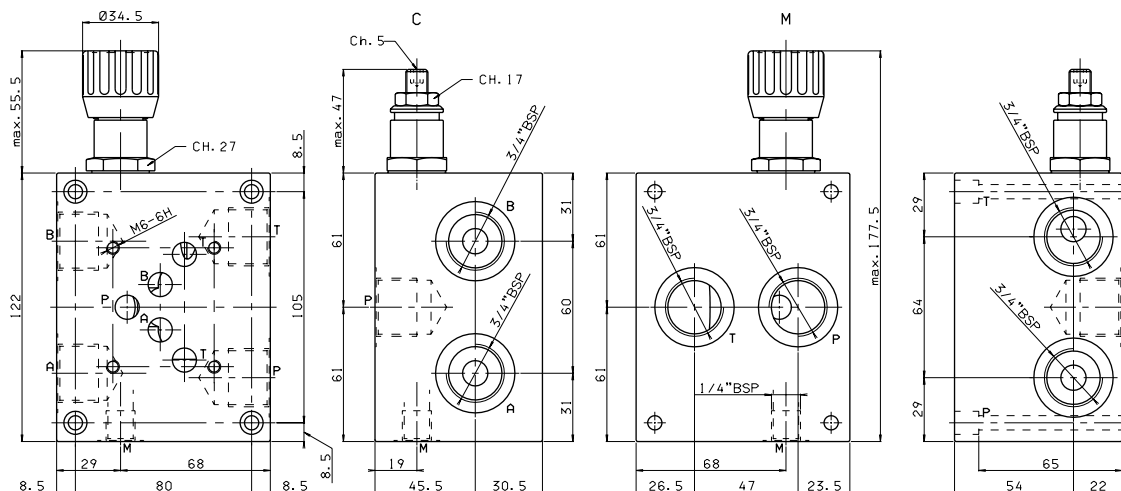

Weight: 6,7 Kg - Fixing screws M6x75 UNI 5931

BS5... SINGLE STATION SUBPLATE

BSVMP20 SINGLE STATION SUBPLATE WITH MAX. PRESSURE VALVE FOR SURFACE MOUNTING (E.G. ON TANK COVER)

- BS** Single subplate
- VMP** Max. pressure valve
- 20** 1/2" BSP connectors
- *** **M** = Plastic knob
C = Grub screw
V = Handwheel
- *** Setting range
1 = max. 30 bar (**white spring**)
2 = max. 140 bar (**yellow spring**)
3 = max. 250 bar (**green spring**)
- 00** No variant
- 1** Serial No.

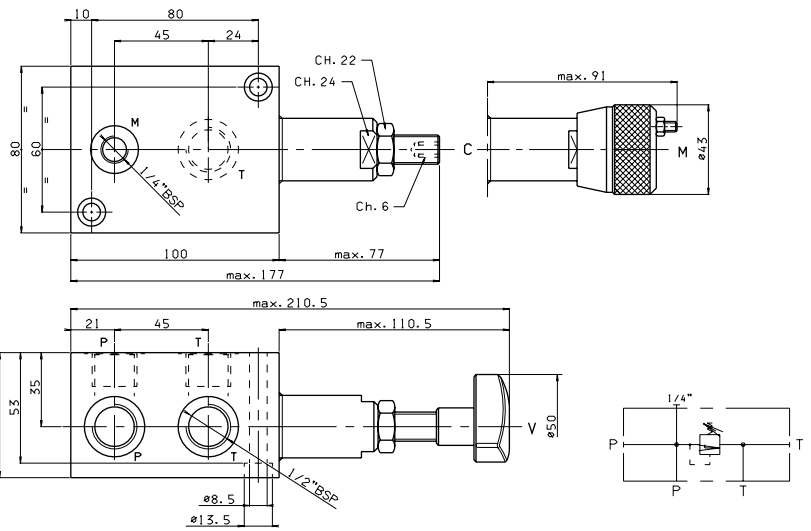

Weight: 3,1 Kg
Fixing screws M8x65 UNI 5931

• The minimum permissible setting pressure depending on the spring: see cartridge valve type CMP20...

BS529 SINGLE STATION SUBPLATE WITH MAX. PRESSURE VALVE FOR AD5I...

- BS** Single subplate
- 5** CETOP 5/NG10
- 29** 1/2" BSP - P rear connector
1/2" BSP - A and B side connectors
1/2" BSP - T rear connector
3/4" BSP - T side connector
- C** Type of adjustment
Grub screw
- *** Setting range
2 = max. 150 bar (**yellow spring**)
3 = max. 320 bar (**green spring**)
- 00** No variant
- 1** Serial No.

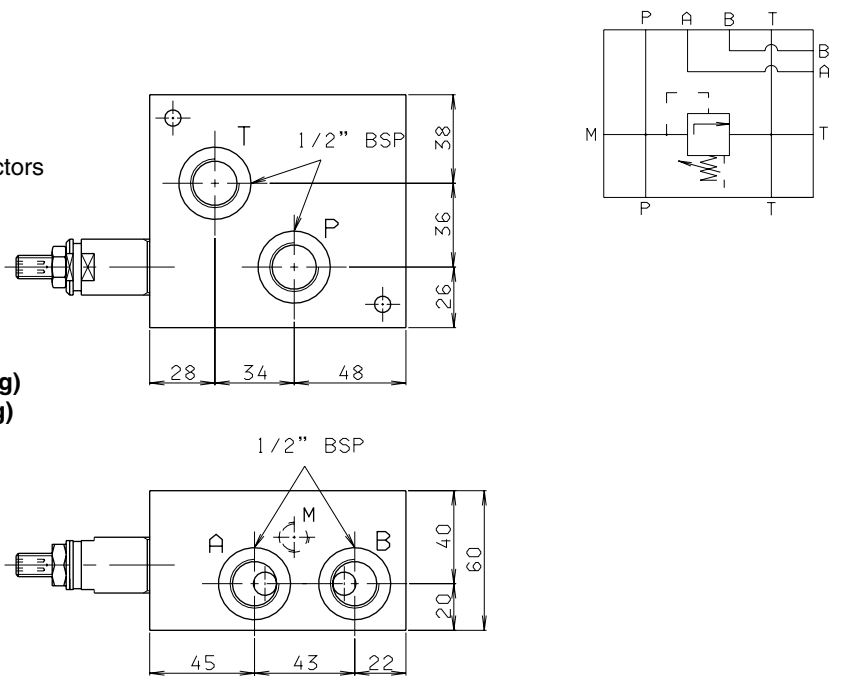

Weight: 4,5 Kg
Fixing screws M6x60 UNI 5931

Tightening torque CMP.10...
60 ÷ 70 Nm / 6 ÷ 7 Kgm

M = Manometer connector (1/4" BSP)

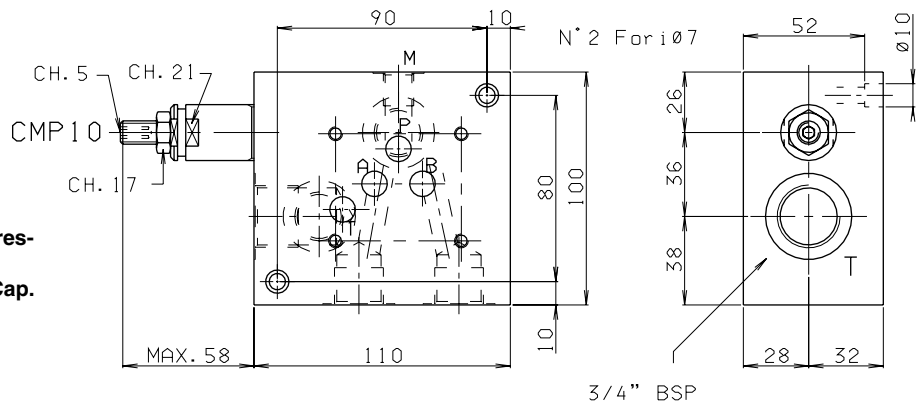

• The minimum permissible setting pressure depending on the spring: see cartridge valve type CMP10... Cap. VII • 30