

EAT•N

Char-Lynn

Hydraulic Motors

General Purpose MotorsR Series



R Series



R

R Series

Geroler® Element	11 Displacements
Flow LPM [GPM]	55 [15] Continuous** 75 [20] Intermittent*
Speed	Up to 1055 RPM
Pressure Bar [PSI]	125 [1800] Cont. 165 [2400] Inter.
Torque Nm [lb-in]	455 [4040] Cont. 520 [4600] Inter.

This Char-Lynn R Series spool valve motor with the Geroler torque generating element is economical, efficient, compact, powerful, and is very effective at low flows and high pressure applications. The outer ring of the Geroler element has seven precision machined rollers that provide rolling contact as the six lobe star orbits within the Geroler element. This orbiting slow turning star coupled to the output shaft with a splined drive provides the hydromechanical six to one advantage. Consequently, with this 6 to 1 reduction built into each motor, gear box speed reducers will not be necessary on most applications.

** Continuous— (Cont.) Continuous rating, motor may be run continuously at these ratings.

* Intermittent— (Inter.) Intermittent operation, 10% of every minute.

R Series Displacement Size = cubic centimeter per shaft revolution (cm^3/r)
= cubic inch per shaft revolution (in^3/r)

- 36 [2.2]
- 49 [3.0]
- 66 [4.0]
- 80 [4.9]
- 102 [6.2]
- 131 [8.0]
- 157 [9.6]
- 195 [11.9]
- 244 [14.9]
- 306 [18.7]
- 370 [22.6]

Mounting Flange

- 2 Bolt (Standard) 82,6 [3.25] Pilot Dia. and 13,59 [.535] Dia. Mounting Holes 106,2 [4.18] Dia. B.C.
- 4 Bolt (Standard) 44,4 [1.75] Pilot Dia. and 3/8-16 Mounting Holes 82,6 [3.25] Dia. B.C.
- 4 Bolt (Standard) 44,4 [1.75] Pilot Dia. and M10 x 1,5 Mounting Holes 82,6 [3.25] Dia. B.C.
- 4 Bolt Magneto 82,6 [3.25] Pilot Dia. and 13,59 [.535] Dia. Mounting Holes 106,2 [4.18] Dia. B.C.

Output Shaft

- 1 inch Dia. Straight with Woodruff Key and 1/4-20 Threaded Hole
- 1 inch Dia. SAE 6B Splined with 1/4-20 Threaded Hole
- 1 inch Dia. Straight with 7,9 [.31] Dia. Crosshole 11,2 [.44] from End
- 1 inch Dia. Straight with 10,2 [.40] Dia. Crosshole 15,7 [.62] from End and 1/4-20 Threaded Hole
- 7/8 inch Dia. SAE B 13 T Splined
- 1 inch Dia. Tapered with Woodruff Key and Nut
- 25mm Dia. Straight with 8mm Key and 8mm x 1,2 Threaded Hole
- 1 inch Dia. Straight with 10,2 [.40] Dia. Crosshole 15,7 [.62] from End and 1/4-20 Threaded Hole (Plated for Corrosion Protection)
- 1 inch Dia. Tapered with Woodruff Key and Nut, 9,52 [.375] Reduced Length

Port Type

- 7/8-14 O-ring
- 1/2-14 NPTF
- Manifold (5/16-18 Mounting Threads)
- Manifold (M8 x 1,5 Mounting Threads)
- G 1/2 (BSP)

Case Drain

- No Case Drain
- 7/16-20 O-ring Port End Cap
- G 1/4 (BSP) Port End Cap

Special Features Available

- Viton® Shaft Seal
- Reverse Rotation
- Flange Rotated 90°
- Corrosion Protected
- Low Speed Valve
- Speed Sensor

Viton® is a Registered Trade Name of Dupont Corp.

R Series

Shaft Seal

This high pressure shaft seal has a patented feature which allows the seal lip to follow shaft deflection, and therefore provides better sealing under high side load conditions. Deflection occurs as radial loads are applied to the output shaft. This time proven shaft seal design and construction is the same as that used in the popular Char-Lynn disc valve motors and is available in either buna or Viton®. With this shaft seal the motors can withstand high back pressures without an external case drain. The motors can be connected together in series, or parallel to one another.

Low Speed Valving

These motors with the low speed valving option provide very low speed while maintaining high torque. Designed to run continuously at up to 200 RPM at standard rated pressures and reduced flows, providing smooth operation at low speeds. Furthermore, they resist slippage and have more momentary load holding ability than the standard R Series motors. Motors with this valving are not intended for low pressure applications (41 Bar [600 PSI] Minimum). Shaft side / radial load ratings are not affected by this valving.

Free Running Motors

R Series motors can be ordered with a special Geroler to permit free running of the output shaft. With this special feature, performance might be affected when extreme conditions exist. Overall efficiency may be reduced slightly.

Corrosion Protected

R Series motors are available with a corrosion resistant coating for use in an hostile environment. This coating protects the motor from salt water and various chemicals. It is especially effective in marine, food processing, car wash, fishing, and agricultural applications. Shaft plating helps eliminate seal damage caused by these caustic or acid materials on this otherwise unprotected shaft sealing area. Corrosion protected motors are available with just the output shaft plated, or protected with an entire motor exterior coating.

Speed Sensor

The R Series motor is available with a rugged digital sensor for monitoring motor shaft speed. Compatible with vehicle electrical systems, this feature is ideal for applications where speeds need to be accurately known.

Catalog Contents

	page
Specifications	5
Performance Data	6- 8
Dimensions — Product (Mtg., Shafts, and Ports Listed Below)	9
Product Numbers (Standard Units)	10
Shaft Side Load Capacity	11
Dimensions — Shafts	12-13
Dimensions — Ports	14
Case Pressure and Case Drain	15-16
Speed Sensor	16
Dimensions — Mtg. Options/Mtg. Kit	17
Fluid Recommendations	18
Model Code (Special* — Orders)	19

* Contact your Eaton Representative

Specifications R Series

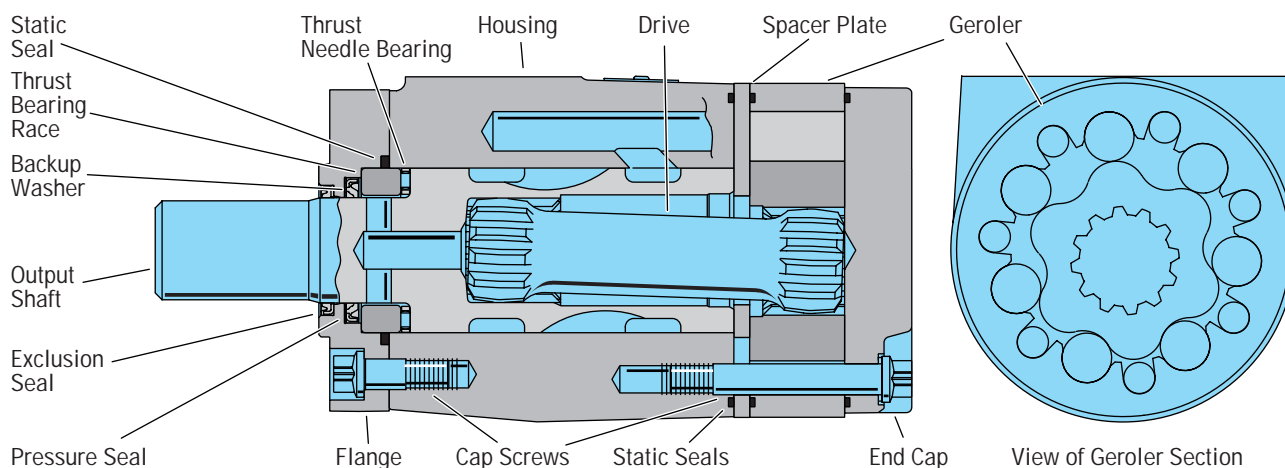

Specification Data —R Series

Displ. cm ³ /r [in ³ /r]		36 [2.2]	49 [3.0]	66 [4.0]	80 [4.9]	102 [6.2]	131 [8.0]	157 [9.6]	195 [11.9]	244 [14.9]	306 [18.7]	370 [22.6]
Max. Speed (RPM) @ Continuous Flow		987	868	805	657	519	401	338	270	215	172	142
Flow LPM [GPM]	Continuous	38 [10]	45 [12]	57 [15]	57 [15]	57 [15]	57 [15]	57 [15]	57 [15]	57 [15]	57 [15]	57 [15]
	Intermittent	38 [10]	53 [14]	64 [17]	68 [18]	68 [18]	76 [20]	76 [20]	76 [20]	76 [20]	76 [20]	76 [20]
Torque Nm [lb-in]	Continuous	58 [517]	81 [721]	110 [971]	135 [1197]	171 [1511]	222 [1968]	269 [2378]	320 [2830]	374 [3310]	423 [3741]	442 [3910]
	Intermittent **	78 [687]	108 [952]	144 [1278]	178 [1577]	226 [1998]	301 [2660]	339 [2996]	378 [3344]	422 [3735]	497 [4398]	520 [4600]
Pressure Δ Bar [Δ PSI]	Continuous*	124 [1800]	124 [1800]	124 [1800]	124 [1800]	124 [1800]	124 [1800]	124 [1800]	121 [1750]	114 [1650]	103 [1500]	90 [1300]
	Intermittent**	165 [2400]	165 [2400]	165 [2400]	165 [2400]	165 [2400]	165 [2400]	159 [2300]	145 [2100]	131 [1900]	124 [1800]	114 [1650]

Maximum Case Pressure w/o Case Drain — 103 Bar [1500 PSI] see page 16

* Maximum intermittent pressure at motor inlet port of 172 Bar [2500 PSI] without regard to Δ Bar [Δ PSI] and/or back pressure ratings or combination thereof.

** A simultaneous maximum torque and maximum speed NOT recommended.

6B Splined or Tapered shafts are recommended whenever operating above 282 Nm [2500 lb-in] of torque, especially for those applications subject to frequent reversals (see page 12).

Δ Bar [Δ PSI]— True pressure difference between inlet port and outlet port.

Continuous Rating — Motor may be run continuously at these ratings.

Intermittent Operation — 10% of every minute.

Recommended Fluids — Premium quality, anti-wear type hydraulic oil with a viscosity of not less than 70 SUS at operating temperature (see page 18).

Recommended Maximum System Operating Temp. — Is 82° C [180° F]

Recommended Filtration — per ISO Cleanliness Code, level 18/13

To assure best motor life, run motor for approximately one hour at 30% of rated pressure before application to full load. Be sure motor is filled with fluid prior to any load applications.



General Purpose Motors

Performance Data R Series

Motors run with high efficiency in all areas designated with a number for torque and speed, however for best motor life select a motor to run with a torque and speed range shown in the light blue area.

36 cm³/r [2.2 in³/r]
Δ Pressure Bar [PSI]

		[200]	[400]	[600]	[800]	[1000]	[1200]	[1400]	[1600]	[1800]	[2400]
		14	28	41	55	69	83	97	110	124	165
Flow LPM [GPM]	[2]	[46] 5	[107] 12	[170] 19	[233] 26	[295] 33	[352] 40	[408] 46	[462] 52	[512] 58	
	7,6	205	198	191	183	175	166	155	140	124	
	[4]	[42] 5	[106] 12	[169] 19	[234] 26	[297] 34	[360] 41	[423] 48	[485] 55	[544] 61	[718] 81
	15,1	413	406	399	389	377	364	350	336	321	261
	[6]	[36] 4	[99] 11	[164] 19	[228] 26	[292] 33	[356] 40	[421] 48	[484] 55	[547] 62	[726] 82
22,7	626	618	610	600	588	575	562	547	533	468	
[8]	[28] 3	[92] 10	[157] 18	[221] 25	[285] 32	[344] 39	[409] 46	[473] 53	[537] 61	[718] 81	
30,3	832	824	815	805	794	781	768	751	737	673	
[10]	[18] 2	[82] 9	[147] 17	[211] 24	[275] 31	[336] 38	[400] 45	[464] 52	[529] 60	[715] 81	
37,9	1038	1032	1021	1012	1000	988	973	955	939	877	

Max. Continuous
Max. Inter-mittent

[82] Torque [lb-in]
9 Nm
1032 Speed RPM

49 cm³/r [3.0 in³/r]
Δ Pressure Bar [PSI]

		[200]	[400]	[600]	[800]	[1000]	[1200]	[1400]	[1600]	[1800]	[2400]
		14	28	41	55	69	83	97	110	124	165
Flow LPM [GPM]	[2]	[68] 8	[156] 18	[242] 27	[327] 37	[412] 47	[493] 56	[571] 65	[644] 73	[711] 80	
	7,6	148	142	137	130	125	118	109	98	82	
	[4]	[66] 7	[154] 17	[242] 27	[330] 37	[418] 47	[505] 57	[592] 67	[677] 76	[761] 86	[1000] 113
	15,1	302	297	291	284	275	265	256	244	231	178
	[6]	[59] 7	[147] 17	[236] 27	[324] 37	[412] 47	[500] 56	[588] 66	[675] 76	[762] 86	[1018] 115
22,7	458	452	445	438	429	420	408	395	382	330	
[8]	[52] 6	[140] 16	[229] 26	[317] 36	[405] 46	[494] 56	[581] 66	[670] 76	[756] 85	[1018] 115	
30,3	608	603	597	590	580	568	557	544	531	478	
[10]	[40] 5	[129] 15	[218] 25	[307] 35	[396] 45	[484] 55	[571] 65	[660] 75	[749] 85	[1011] 114	
37,9	759	754	746	739	730	719	707	694	679	624	
[12]	[28] 3	[117] 13	[206] 23	[293] 33	[383] 43	[471] 53	[560] 63	[648] 73	[736] 83	[998] 113	
45,4	911	904	896	888	878	867	855	843	829	770	
Max. Inter-mittent	[14]	[15] 2	[103] 12	[189] 21	[280] 32	[369] 42	[457] 52	[546] 62	[635] 72	[724] 82	
	53,0	1062	1052	1045	1036	1026	1014	1002	988	970	

66 cm³/r [4.0 in³/r]
Δ Pressure Bar [PSI]

		[200]	[400]	[600]	[800]	[1000]	[1200]	[1400]	[1600]	[1800]	[2400]
		14	28	41	55	69	83	97	110	124	165
Flow LPM [GPM]	[2]	[102] 12	[218] 25	[334] 38	[452] 51	[566] 64	[680] 77	[799] 89	[896] 101	[993] 112	
	7,6	111	107	103	100	94	89	81	72	61	
	[4]	[95] 11	[213] 24	[331] 37	[448] 51	[565] 64	[683] 77	[799] 90	[914] 103	[1028] 116	[1357] 153
	15,1	226	223	219	212	206	200	192	184	173	136
	[6]	[89] 10	[206] 23	[324] 37	[442] 50	[561] 63	[678] 77	[795] 90	[908] 103	[1024] 116	[1368] 155
22,7	344	340	334	328	322	315	308	300	290	254	
[8]	[75] 8	[192] 22	[311] 35	[429] 48	[550] 62	[668] 75	[786] 89	[903] 102	[1021] 115	[1369] 155	
30,3	458	454	449	443	436	431	423	414	404	363	
[10]	[62] 7	[180] 20	[298] 34	[416] 47	[535] 60	[651] 74	[769] 87	[888] 100	[1006] 114	[1354] 153	
37,9	572	568	563	557	550	542	535	525	514	474	
[12]	[45] 5	[164] 19	[282] 32	[400] 45	[518] 59	[636] 72	[755] 85	[874] 99	[990] 112	[1342] 152	
45,4	687	681	675	670	664	655	648	637	627	584	
[14]	[29] 3	[146] 16	[265] 30	[384] 43	[503] 57	[621] 70	[738] 83	[857] 97	[976] 110	[1329] 150	
53,0	800	795	790	783	776	767	760	749	737	694	
Max. Continuous	[15]	[28] 3	[131] 15	[252] 28	[370] 42	[489] 55	[607] 69	[724] 82	[843] 95	[963] 109	[1319] 149
56,8	857	853	848	842	835	828	821	810	797	748	
Max. Inter-mittent	[17]		[116] 13	[235] 27	[353] 40	[470] 53	[589] 67	[707] 80	[825] 93	[944] 107	
	64,4		965	959	952	945	936	926	915	901	

80 cm³/r [4.9 in³/r]
Δ Pressure Bar [PSI]

		[200]	[400]	[600]	[800]	[1000]	[1200]	[1400]	[1600]	[1800]	[2400]
		14	28	41	55	69	83	97	110	124	165
Flow LPM [GPM]	[2]	[115] 13	[258] 29	[400] 45	[539] 61	[675] 76	[809] 91	[940] 106	[1069] 121	[1191] 135	
	7,6	91	89	86	82	78	74	68	62	53	
	[4]	[114] 13	[259] 29	[404] 46	[548] 62	[690] 78	[828] 94	[967] 109	[1103] 125	[1238] 140	[1633] 184
	15,1	185	182	178	174	169	164	158	150	142	108
	[6]	[106] 12	[251] 28	[395] 45	[539] 61	[683] 77	[825] 93	[966] 109	[1104] 125	[1242] 140	[1651] 187
22,7	281	277	273	268	263	258	251	243	235	201	
[8]	[93] 11	[237] 27	[380] 43	[526] 59	[671] 76	[814] 92	[955] 108	[1095] 124	[1235] 140	[1649] 186	
30,3	374	370	366	361	356	350	343	334	325	291	
[10]	[77] 9	[221] 25	[365] 41	[510] 58	[654] 74	[796] 90	[937] 106	[1081] 122	[1220] 138	[1636] 185	
37,9	468	464	459	454	448	441	434	425	416	379	
[12]	[56] 6	[201] 23	[345] 39	[490] 55	[635] 72	[779] 88	[923] 104	[1064] 120	[1207] 136	[1627] 184	
45,4	561	557	552	546	539	532	525	517	506	468	
[14]	[39] 4	[181] 20	[326] 37	[470] 53	[617] 70	[758] 86	[902] 102	[1046] 118	[1189] 134	[1610] 182	
53,0	655	650	644	639	632	624	617	606	596	555	
Max. Continuous	[15]		[170] 19	[315] 36	[462] 52	[606] 68	[751] 85	[895] 101	[1040] 117	[1181] 133	[1604] 181
56,8		696	692	686	680	672	662	653	642	596	
Max. Inter-mittent	[18]		[127] 14	[272] 31	[415] 47	[559] 63	[703] 79	[847] 96	[992] 112	[1136] 128	
	68,1		834	829	824	816	808	799	788	776	

Performance data is typical at 120 SUS. Actual data may vary slightly from unit to unit in production

Performance Data R Series

Motors run with high efficiency in all areas designated with a number for torque and speed, however for best motor life select a motor to run with a torque and speed range shown in the light blue area.

		102 cm ³ /r [6.2 in ³ /r] Δ Pressure Bar [PSI]										Max. Continuous	Max. Inter-mittent
		[200]	[400]	[600]	[800]	[1000]	[1200]	[1400]	[1600]	[1800]	[2400]		
		14	28	41	55	69	83	97	110	124	165		
Flow LPM [GPM]	[2]	[151]	[328]	[508]	[688]	[865]	[1038]	[1202]	[1361]	[1508]			
	7.6	17	37	57	78	98	117	136	154	170			
		72	70	67	64	61	56	50	44	36			
	[4]	[157]	[339]	[520]	[703]	[882]	[1063]	[1241]	[1416]	[1587]	[2065]		
	15.1	18	38	59	79	100	120	140	160	179	233		
		146	144	141	137	133	128	122	114	106	77		
[6]	[143]	[326]	[508]	[691]	[873]	[1054]	[1234]	[1412]	[1587]	[2083]			
22.7	16	37	57	78	99	119	139	160	179	235			
	221	219	212	207	202	197	190	183	173	142			
[8]	[121]	[303]	[485]	[668]	[850]	[1032]	[1211]	[1391]	[1569]	[2083]			
30.3	14	34	55	75	96	117	137	157	177	235			
	295	293	290	285	280	275	268	261	252	217			
[10]	[107]	[291]	[473]	[654]	[838]	[1019]	[1201]	[1380]	[1559]	[2074]			
37.9	12	33	53	73	95	115	136	156	176	234			
	370	367	363	359	354	348	342	334	325	288			
[12]	[81]	[264]	[448]	[632]	[815]	[996]	[1177]	[1359]	[1527]	[2066]			
45.4	9	30	51	71	92	113	133	154	173	233			
	444	441	437	432	427	421	415	406	396	358			
[14]	[55]	[239]	[420]	[603]	[784]	[968]	[1150]	[1332]	[1513]	[2043]			
53.0	6	27	47	68	89	109	130	150	171	231			
	518	515	511	506	500	494	487	479	469	42			
[15]	[37]	[222]	[405]	[587]	[769]	[952]	[1135]	[1314]	[1501]	[2032]			
Max. Continuous	4	25	46	66	87	108	128	149	170	230			
56.8	555	551	547	543	538	532	524	514	504	464			
Max. Inter-mittent	[18]		[169]	[353]	[534]	[720]	[902]	[1085]	[1267]	[1447]			
	68.1		662	657	653	647	640	633	623	612			

		131 cm ³ /r [8.0 in ³ /r] Δ Pressure Bar [PSI]										Max. Continuous	Max. Inter-mittent
		[200]	[400]	[600]	[800]	[1000]	[1200]	[1400]	[1600]	[1800]	[2400]		
		14	28	41	55	69	83	97	110	124	165		
Flow LPM [GPM]	[2]	[119]	[363]	[612]	[848]	[1077]	[1298]	[1505]	[1694]	[1934]			
	7.6	13	41	69	96	122	147	170	191	219			
		55	54	52	50	47	44	40	33	29			
	[4]	[185]	[421]	[660]	[896]	[1126]	[1356]	[1581]	[1798]	[2005]	[2585]		
	15.1	21	48	75	101	127	153	179	203	227	292		
		113	111	109	106	103	100	95	90	84	56		
[6]	[179]	[417]	[656]	[892]	[1123]	[1353]	[1583]	[1803]	[2015]	[2639]			
22.7	20	47	74	101	127	153	179	204	228	298			
	172	169	166	164	161	157	152	147	141	109			
[8]	[165]	[403]	[639]	[875]	[1109]	[1341]	[1569]	[1791]	[2003]	[2634]			
30.3	19	46	72	99	125	152	177	202	226	298			
	229	227	224	221	218	214	209	204	198	163			
[10]	[142]	[378]	[618]	[855]	[1091]	[1323]	[1554]	[1778]	[1992]	[2608]			
37.9	16	43	70	97	123	149	176	201	225	295			
	287	284	281	278	275	271	266	261	255	219			
[12]	[114]	[352]	[589]	[826]	[1062]	[1297]	[1526]	[1747]	[1948]	[2579]			
45.4	13	40	67	93	120	147	172	197	220	291			
	344	341	338	335	332	328	323	319	313	274			
[14]	[102]	[320]	[556]	[791]	[1028]	[1261]	[1493]	[1715]	[1922]	[2566]			
53.0	12	36	63	89	116	142	168	194	217	290			
	401	398	395	393	388	385	380	375	370	328			
[15]	[98]	[301]	[539]	[775]	[1013]	[1245]	[1476]	[1694]	[1906]	[2553]			
Max. Continuous	11	34	61	88	114	141	167	191	215	288			
56.8	430	427	424	421	417	413	408	403	398	356			
Max. Inter-mittent	[20]		[226]	[423]	[659]	[894]	[1129]	[1360]	[1572]	[1784]			
	75.7		26	48	74	101	128	154	178	202			
			570	566	562	558	554	549	543	533			

		157 cm ³ /r [9.6 in ³ /r] Δ Pressure Bar [PSI]										Max. Continuous	Max. Inter-mittent
		[200]	[400]	[600]	[800]	[1000]	[1200]	[1400]	[1600]	[1800]	[2300]		
		14	28	41	55	69	83	97	110	124	159		
Flow LPM [GPM]	[2]	[229]	[507]	[786]	[1052]	[1315]	[1566]	[1813]	[2038]	[2229]			
	7.6	26	57	89	119	149	177	205	230	252			
		46	45	43	41	39	36	32	27	20			
	[4]	[245]	[532]	[818]	[1099]	[1373]	[1638]	[1898]	[2149]	[2385]	[2967]		
	15.1	28	60	92	124	155	185	214	243	269	335		
		94	92	90	87	85	81	77	72	66	47		
[6]	[231]	[516]	[802]	[1085]	[1366]	[1640]	[1904]	[2159]	[2396]	[3015]			
22.7	26	58	91	123	154	185	215	244	271	341			
	143	140	137	134	132	128	124	119	113	88			
[8]	[208]	[495]	[784]	[1068]	[1351]	[1631]	[1900]	[2159]	[2383]	[3012]			
30.3	23	56	89	121	153	184	215	243	269	340			
	190	188	185	182	178	175	171	166	158	136			
[10]	[178]	[467]	[755]	[1038]	[1322]	[1603]	[1879]	[2133]	[2368]	[2989]			
37.9	20	53	85	117	149	181	212	241	268	338			
	238	235	232	229	225	222	218	213	205	176			
[12]	[143]	[431]	[719]	[1005]	[1290]	[1569]	[1845]	[2104]	[2332]	[2965]			
45.4	16	49	81	114	146	177	208	238	263	335			
	286	283	280	277	273	268	264	259	252	224			
[14]	[101]	[392]	[680]	[966]	[1252]	[1530]	[1803]	[2061]	[2298]	[2935]			
53.0	11	44	77	109	141	171	204	233	260	332			
	333	330	327	323	319	314	311	306	298	267			
[15]	[88]	[368]	[659]	[946]	[1230]	[1510]	[1789]	[2034]	[2274]	[2919]			
Max. Continuous	10	42	74	107	139	171	202	230	257	330			
56.8	357	354	351	347	344	340	335	330	322	289			
Max. Inter-mittent	[20]		[229]	[516]	[796]	[1084]	[1368]	[1645]	[1912]	[2144]			
	75.7		26	58	90	122	155	186	216	242			
			472	468	465	460	455	450	444	435			

		195 cm ³ /r [11.9 in ³ /r] Δ Pressure Bar [PSI]										Max. Continuous	Max. Inter-mittent
		[200]	[400]	[600]	[800]	[1000]	[1200]	[1400]	[1600]	[1750]	[2100]		
		14	28	41	55	69	83	97	110	121	145		
Flow LPM [GPM]	[2]	[207]	[566]	[921]	[1256]	[1577]	[1889]	[2179]	[2407]	[2561]			
	7.6	23	64	104	142	178	213	246	272	289			
		37	36	34	33	31	28	24	17	11			
	[4]	[359]	[618]	[967]	[1315]	[1654]	[1977]	[2289]	[2583]	[2794]	[3262]		
	15.1	29	70	109	149	187	223	259	292	316	369		
		76	74	72	70	68	64	61	55	51	35		
[6]	[274]	[628]	[977]	[1322]	[1665]	[1995]	[2308]	[2597]	[2816]	[3340]			
22.7	31	71	110	149	188	225	261	293	318	377			
	115	113	111	109	106	103	100	95	89	74			
[8]	[253]	[610]	[961]	[1307]	[1652]	[1987]	[2298]	[2579]	[2810]	[3344]			
30.3	29	69	109	148	187	224	260	291	317	378			
	154	152	150	148	145	142	138	133	127	110			
[10]	[217]	[569]	[923]	[1267]	[1611]	[1951]	[2274]	[2566]	[2784]	[3320]			
37.9	25	64	104	143	182	220	257	290	315	375			
	193	191	189	187	184	181	177	172	165	144			
[12]	[184]	[539]	[892]	[1239]	[1586]	[1925]	[2239]	[2526]	[2750]	[3280]			
45.4	21	61	101	140	179	217	253	285	311	371			
	231	229	227	224	221	217	214	210	202	180			
[14]	[128]	[485]	[838]	[1191]	[1536]	[1880]	[2193]	[2477]	[2701]	[3242]			
53.0	14	55	95	135	174	212	248	280	305	366			
	270	268	265	263	259	255	252	247	240	218			
[15]	[111]	[461]	[816]	[1167]	[1512]	[1851]	[2170]	[2455]	[2679]	[3227]			
Max. Continuous	13	52	92	132	171	209	245	277	303	365			
56.8	289	287	285	281	278	274	270	265	259	237			
Max. Inter-mittent	[20]		[293]	[648]	[1000]	[1345]	[1688]	[2013]	[2289]	[2527]			
	75.7		33	73	113	152	191	227	259	286			
			383	380	377</								



General Purpose Motors

Performance Data R Series

Motors run with high efficiency in all areas designated with a number for torque and speed, however for best motor life select a motor to run with a torque and speed range shown in the light blue area.

244 cm³/r [14.9 in³/r]
Δ Pressure Bar [PSI]

	[200]	[400]	[600]	[800]	[1000]	[1200]	[1400]	[1600]	[1650]	[1900]
	14	28	41	55	69	83	97	110	114	131
[2]	[311]	[744]	[1183]	[1592]	[1981]	[2352]	[2691]	[2963]	[3039]	
	35	84	134	180	224	266	304	335	343	
7,6	30	29	28	26	24	22	18	14	11	
[4]	[361]	[801]	[1238]	[1669]	[2089]	[2491]	[2851]	[3205]	[3292]	[3697]
	41	90	140	189	236	281	322	362	372	418
15,1	61	59	58	56	54	52	49	44	42	34
[6]	[347]	[792]	[1235]	[1665]	[2098]	[2516]	[2892]	[3239]	[3320]	[3771]
	39	89	140	188	237	284	327	366	375	426
22,7	92	91	89	87	85	83	80	75	73	63
[8]	[317]	[762]	[1202]	[1634]	[2062]	[2476]	[2856]	[3226]	[3317]	[3779]
	36	86	136	185	233	280	323	364	375	427
30,3	123	121	120	118	116	114	111	105	103	90
[10]	[278]	[721]	[1166]	[1600]	[2029]	[2450]	[2808]	[3178]	[3275]	[3746]
	31	81	132	181	229	277	317	359	370	423
37,9	153	152	150	149	146	144	141	135	133	119
[12]	[229]	[673]	[1114]	[1554]	[1983]	[2399]	[2770]	[3130]	[3228]	[3699]
	26	76	126	176	224	271	313	354	365	418
45,4	185	183	181	179	177	174	171	165	163	148
[14]	[168]	[614]	[1059]	[1494]	[1927]	[2348]	[2728]	[3081]	[3171]	[3649]
	19	69	120	169	218	265	308	348	358	412
53,0	215	214	211	209	207	204	201	195	194	178
[15]	[132]	[581]	[1025]	[1463]	[1894]	[2315]	[2694]	[3043]	[3144]	[3621]
	15	66	116	165	214	262	304	344	355	409
56,8	231	229	227	224	222	219	216	211	208	193
Max. Continuous	[20]	[377]	[818]	[1255]	[1686]	[2104]	[2477]	[2838]	[2929]	
		43	92	142	190	238	280	321	331	
Max. Inter-mittent	75,7	306	303	301	298	295	292	284	282	

306 cm³/r [18.7 in³/r]
Δ Pressure Bar [PSI]

	[200]	[400]	[600]	[800]	[1000]	[1200]	[1300]	[1500]	[1800]
	14	28	41	55	69	83	90	103	124
[2]	[332]	[913]	[1484]	[2029]	[2532]	[2971]	[3199]	[3533]	
	38	103	168	229	286	336	361	399	
7,6	24	23	22	21	20	19	18	14	
[4]	[400]	[977]	[1543]	[2092]	[2599]	[3072]	[3311]	[3766]	[4329]
	45	110	174	236	294	347	374	425	489
15,1	48	47	47	46	45	44	43	40	30
[6]	[402]	[969]	[1533]	[2079]	[2581]	[3046]	[3290]	[3750]	[4390]
	45	109	173	235	292	344	372	424	496
22,7	73	73	72	71	71	70	69	66	58
[8]	[383]	[948]	[1502]	[2041]	[2537]	[3006]	[3249]	[3716]	[4361]
	43	107	170	231	287	340	367	420	493
30,3	98	97	96	96	96	95	94	91	82
[10]	[338]	[896]	[1449]	[1986]	[2471]	[2939]	[3183]	[3647]	[4296]
	38	101	164	224	279	332	360	412	485
37,9	122	122	121	121	120	120	119	116	106
[12]	[287]	[842]	[1391]	[1917]	[2382]	[2868]	[3112]	[3580]	[4221]
	32	95	157	217	270	324	352	404	477
45,4	147	146	146	146	145	145	144	140	129
[14]	[217]	[773]	[1324]	[1846]	[2312]	[2785]	[3028]	[3498]	[4152]
	25	87	150	209	261	315	342	395	469
53,0	172	171	170	169	170	169	169	165	152
[15]	[169]	[729]	[1280]	[1816]	[2271]	[2746]	[2988]	[3460]	[4116]
	19	82	145	205	257	310	338	391	465
56,8	183	183	182	182	181	177	171	151	164
Max. Continuous	[20]	[469]	[1020]	[1549]	[2013]	[2467]	[2710]	[3185]	
		53	115	175	227	279	306	360	
Max. Inter-mittent	75,7	244	243	243	243	242	241	237	

[729] Torque [lb-in]
82 Nm
183 Speed RPM

370 cm³/r [22.6 in³/r]
Δ Pressure Bar [PSI]

	[200]	[400]	[600]	[800]	[1000]	[1200]	[1300]	[1500]
	14	28	41	55	69	83	90	103
[2]	[476]	[1166]	[1835]	[2464]	[3043]			
	54	132	207	278	344			
7,6	19	19	18	17	16			
[4]	[552]	[1226]	[1895]	[2540]	[3124]	[3639]	[3892]	[4386]
	62	139	214	287	353	411	440	496
15,1	40	39	39	38	37	35	33	29
[6]	[544]	[1218]	[1879]	[2531]	[3108]	[3628]	[3886]	[4406]
	61	138	212	286	351	410	439	498
22,7	60	60	59	59	58	56	54	49
[8]	[504]	[1177]	[1836]	[2484]	[3066]	[3578]	[3853]	[4380]
	57	133	207	281	346	404	435	495
30,3	81	80	80	79	79	77	75	69
[10]	[442]	[1114]	[1772]	[2414]	[2986]	[3503]	[3782]	[4317]
	50	126	200	273	337	396	427	488
37,9	101	101	100	99	99	97	94	89
[12]	[359]	[1031]	[1690]	[2330]	[2916]	[3423]	[3690]	[4226]
	41	116	191	263	329	387	417	477
45,4	122	121	121	120	119	117	115	108
[14]	[273]	[946]	[1605]	[2240]	[2830]	[3328]	[3600]	[4134]
	31	107	181	253	320	376	407	467
53,0	142	141	140	140	139	137	135	128
[15]	[223]	[893]	[1554]	[2188]	[2777]	[3272]	[3550]	[4085]
	25	101	176	247	314	370	401	462
56,8	152	151	150	150	150	148	145	138
Max. Continuous	[20]	[569]	[1231]	[1861]	[2458]	[2968]	[3238]	
		64	139	210	278	335	366	
Max. Inter-mittent	75,7	202	201	200	200	197	195	

Performance data is typical at 120 SUS. Actual data may vary slightly from unit to unit in production

Dimensions R Series

2 Bolt Flange

82,55/82,42
[3.250/3.245]
Pilot Dia.

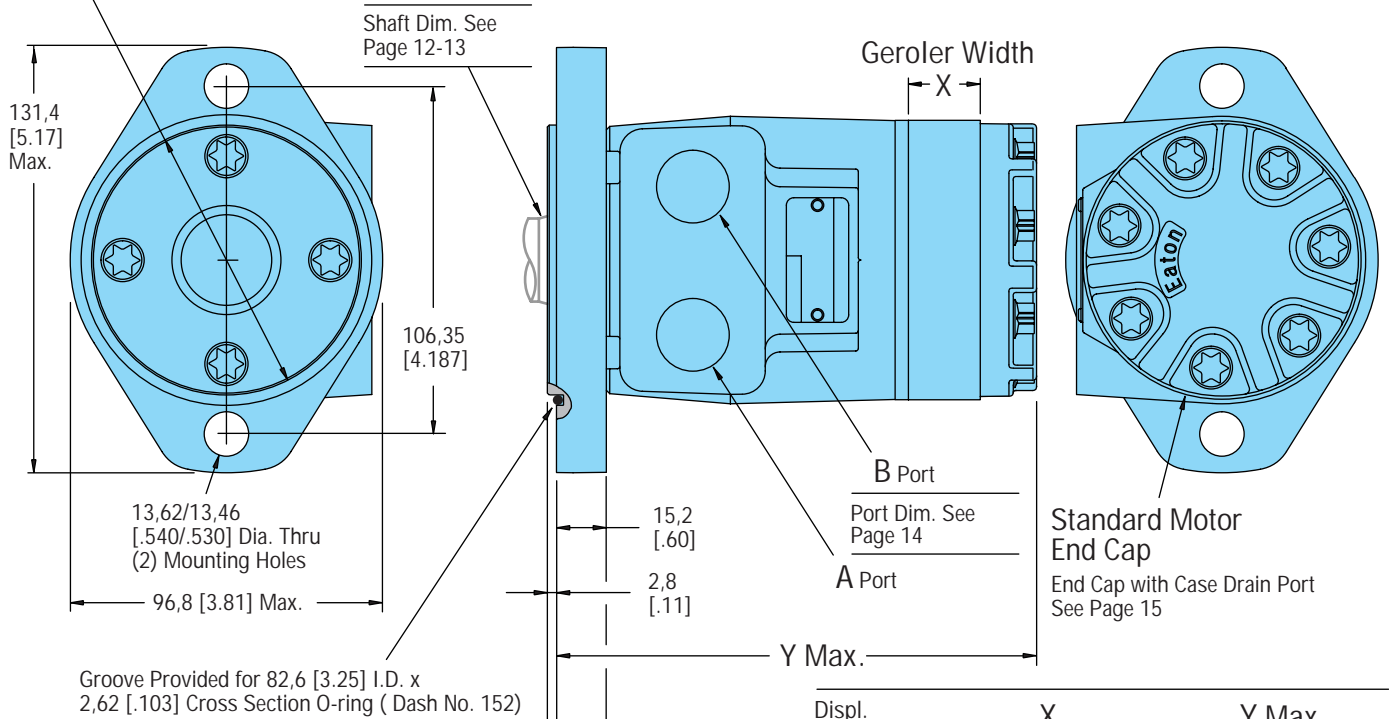

Standard Rotation
Viewed from Shaft End
Port A Pressurized — CW
Port B Pressurized — CCW

4 Bolt Flange

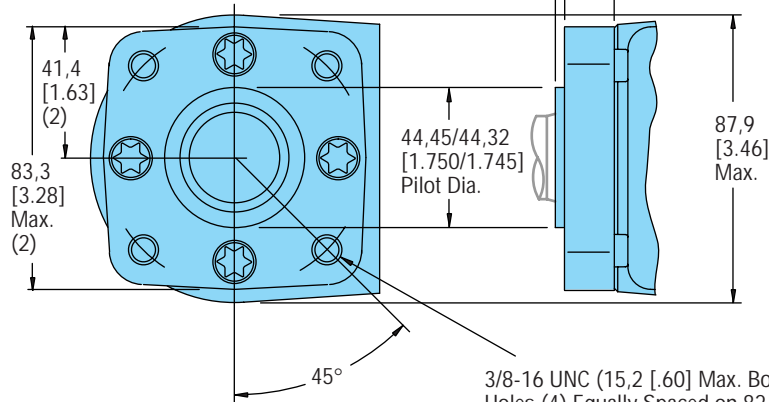

3/8-16 UNC (15,2 [.60] Max. Bolt Thread Engagement) Mounting Holes (4) Equally Spaced on 82,6 [3.25] Dia. Bolt Circle
or
M10 x 1,5 (15,2 [.60] Max. Bolt Thread Engagement) Mounting Holes (4) Equally Spaced on 82,6 [3.25] Dia. Bolt Circle

Displ. cm ³ /r [in ³ /r]	X	Y Max.
	Width mm [in.]	Length mm [in.]
36 [2.2]	6,6 [.26]	132,2 [5.21]
49 [3.0]	9,1 [.36]	134,6 [5.30]
66 [4.0]	12,2 [.48]	137,7 [5.42]
80 [4.9]	14,7 [.58]	140,3 [5.53]
102 [6.2]	18,5 [.73]	144,3 [5.68]
131 [8.0]	24,1 [.95]	149,6 [5.89]
157 [9.6]	29,0 [1.14]	154,5 [6.09]
195 [11.9]	35,6 [1.40]	161,3 [6.35]
244 [14.9]	44,7 [1.76]	170,3 [6.71]
306 [18.7]	56,1 [2.21]	181,6 [7.16]
370 [22.6]	72,1 [2.84]	197,9 [7.79]

Product Numbers

R Series 146-xxxx

Product Numbers—R Series

Add three digit prefix —146—to four digit number from chart for complete product number—Example 146-1204.
Orders will not be accepted without three digit prefix.

Mounting	Shaft	Ports	Displ. cm ³ /r [in ³ /r] Product Number 146-xxxx										
			36 [2.2]	49 [3.0]	66 [4.0]	80 [4.9]	102 [6.2]	131 [8.0]	157 [9.6]	195 [11.9]	244 [14.9]	306 [18.7]	370 [22.6]
2 Bolt Flange	1 in. Straight w/Woodruff Key	7/8-14 O-ring	146-1041	-1042	-1043	-1044	-1045	-1046	-1047	-1048	-1049	-1050	—
		1/2 NPTF	146-1031	-1032	-1033	-1034	-1035	-1036	-1037	-1038	-1039	-1040	—
		Manifold*	146-1051	-1052	-1053	-1054	-1055	-1056	-1057	-1058	-1059	-1060	—
	1 in. SAE 6B Splined	7/8-14 O-ring	146-1101	-1102	-1103	-1104	-1105	-1106	-1107	-1108	-1109	-1110	—
		1/2 NPTF	146-1091	-1092	-1093	-1094	-1095	-1096	-1097	-1098	-1099	-1100	—
		Manifold*	146-1111	-1112	-1113	-1114	-1115	-1116	-1117	-1118	-1119	-1120	—
	1 in. Straight w/.31 Dia. Crosshole	7/8-14 O-ring	146-1121	-1122	-1123	-1124	-1125	-1126	-1127	—	—	—	—
		1/2 NPTF	146-1128	-1129	-1130	-1131	-1132	-1133	-1134	—	—	—	—
		Manifold*	146-1135	-1136	-1137	-1138	-1139	-1140	-1141	—	—	—	—
	1 in. Straight w/.40 Dia. Crosshole	7/8-14 O-ring	146-1142	-1143	-1144	-1145	-1146	-1147	-1148	—	—	—	—
		1/2 NPTF	146-1149	-1150	-1151	-1152	-1153	-1154	-1155	—	—	—	—
		Manifold*	146-1156	-1157	-1158	-1159	-1160	-1161	-1162	—	—	—	—
4 Bolt Flange	1 in. Straight w/Woodruff Key	7/8-14 O-ring	146-1011	-1012	-1013	-1014	-1015	-1016	-1017	-1018	-1019	-1020	—
		1/2 NPTF	146-1001	-1002	-1003	-1004	-1005	-1006	-1007	-1008	-1009	-1010	—
		Manifold*	146-1021	-1022	-1023	-1024	-1025	-1026	-1027	-1028	-1029	-1030	—
	1 in. SAE 6B Splined	7/8-14 O-ring	146-1071	-1072	-1073	-1074	-1075	-1076	-1077	-1078	-1079	-1080	—
		1/2 NPTF	146-1061	-1062	-1063	-1064	-1065	-1066	-1067	-1068	-1069	-1070	—
		Manifold*	146-1081	-1082	-1083	-1084	-1085	-1086	-1087	-1088	-1089	-1090	—
	1 in. Straight w/.31 Dia. Crosshole	7/8-14 O-ring	146-1163	-1164	-1165	-1166	-1167	-1168	-1169	—	—	—	—
		1/2 NPTF	146-1170	-1171	-1172	-1173	-1174	-1175	-1176	—	—	—	—
		Manifold*	146-1177	-1178	-1179	-1180	-1181	-1182	-1183	—	—	—	—
	1 in. Straight w/.40 Dia. Crosshole	7/8-14 O-ring	146-1184	-1185	-1186	-1187	-1188	-1189	-1190	—	—	—	—
		1/2 NPTF	146-1191	-1192	-1193	-1194	-1195	-1196	-1197	—	—	—	—
		Manifold*	146-1198	-1199	-1200	-1201	-1202	-1203	-1204	—	—	—	—

*Manifold product numbers shown are 5/16-18 port face mounting threads (for M8 x 1,5 port face mounting threads see note below).

146-1204

For R Series motors with a configuration *Not Shown* in the chart above: Use the model code number system on page 19 to specify the product in detail.

Shaft Side Load Capacity R Series

The hydrodynamic bearing has infinite life when shaft load ratings are not exceeded. Hence, the shaft side load capacity is more than adequate to handle most externally applied loads (such as belts, chains, etc.), providing the motor to shaft size is applied within its torque rating.

Allowable side load chart, shaft load location drawing and load curves (below) are based on the side / radial loads being applied to shaft at locations A, B, and C, to determine the shaft side load capacity at locations other than those shown use the formula (shown below). For more information about shaft side loads on Char-Lynn motors contact your Eaton representative.

$$\text{Sideload } P \text{ kg} = \frac{900}{N} \left(\frac{16800}{L + 96,3} \right) \quad \text{for 200-900 RPM}$$

$$\text{Sideload } P \text{ [lb]} = \frac{900}{N} \left(\frac{1460}{L + [3.79]} \right) \quad \text{for 200-900 RPM}$$

Where N = Shaft Speed (RPM)

L = Distance from Mounting Surface

RPM	Allowable Shaft Side Load —Kg [lb]		
	A	B	C
900	154 [339]	136 [300]	118 [261]
625	205 [452]	181 [400]	158 [348]
500	256 [565]	227 [500]	197 [435]
400	307 [678]	272 [600]	237 [522]
300	410 [904]	363 [800]	316 [696]
200	718 [1582]	635 [1400]	552 [1216]

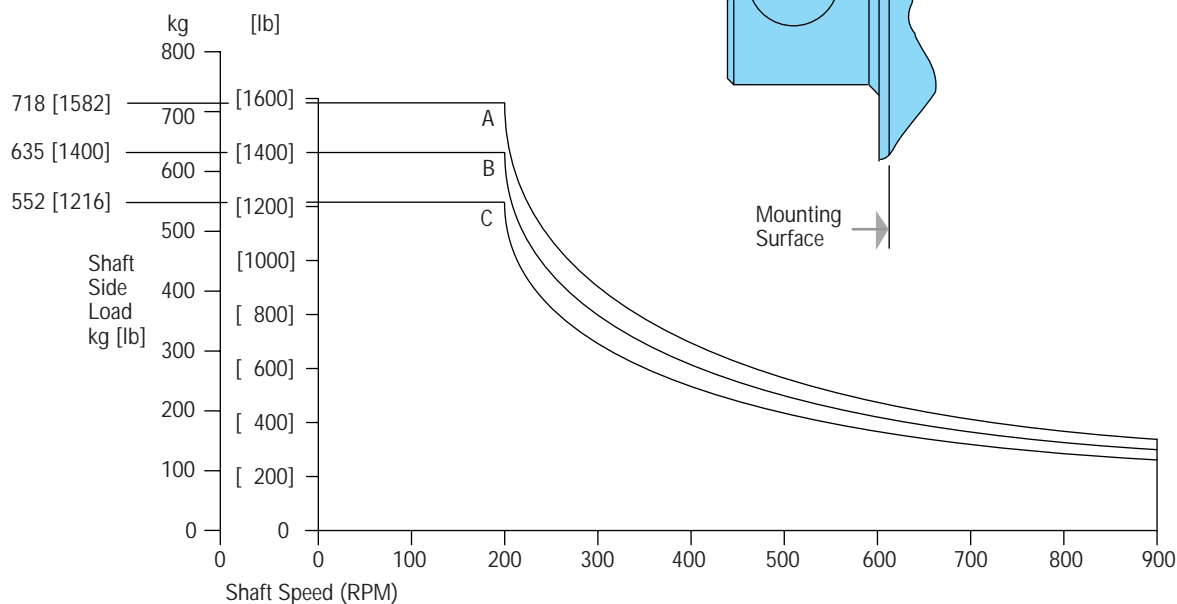
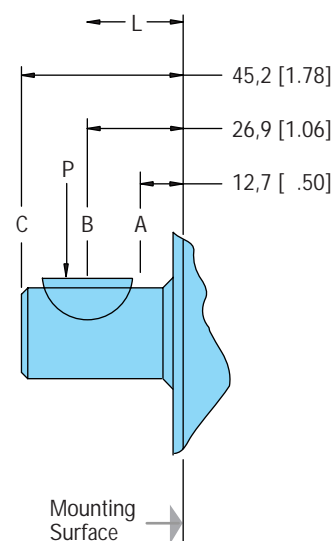

Dimensions — Shafts

R Series

Shaft Size /Motor Torque Combination Limit Guide

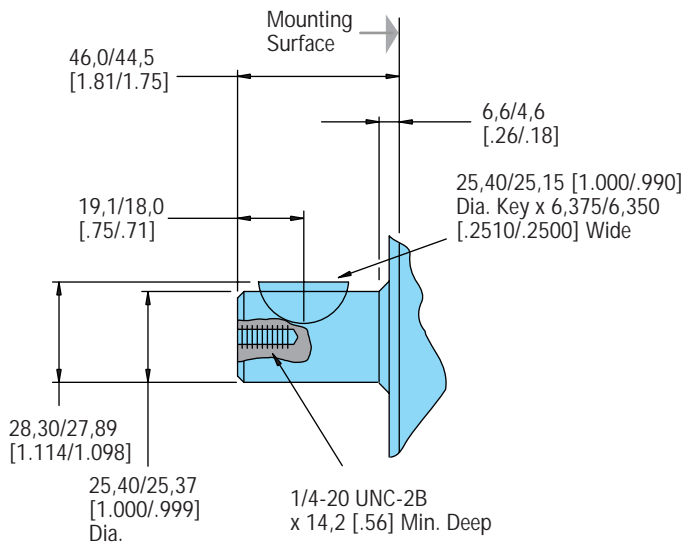
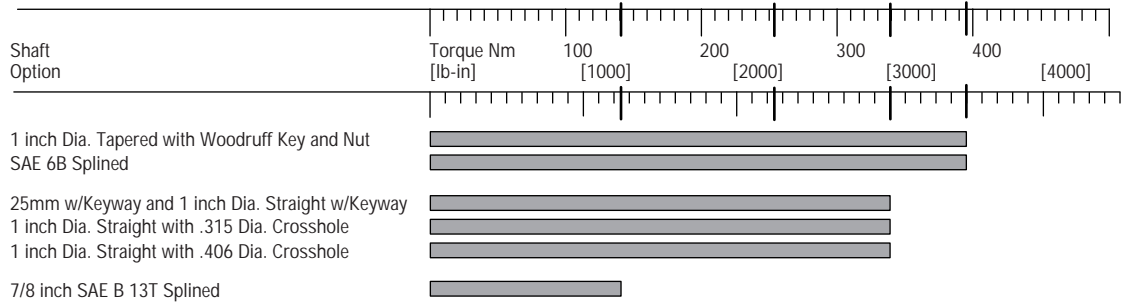

1 in. Dia. Straight with Woodruff Key

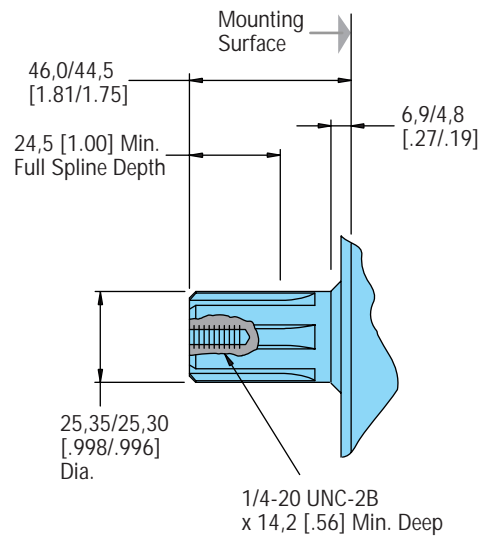

SAE 6B Splined Shaft

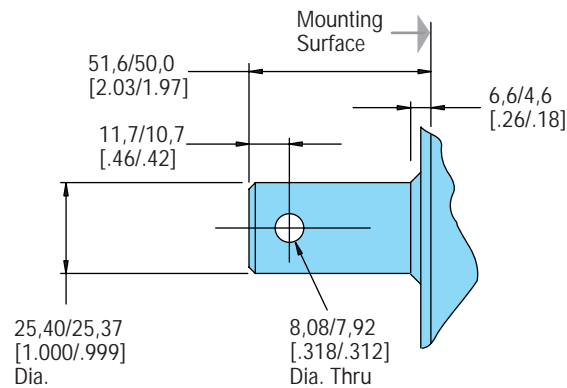

1 in. Dia. Straight Shaft with .315 Dia. Crosshole

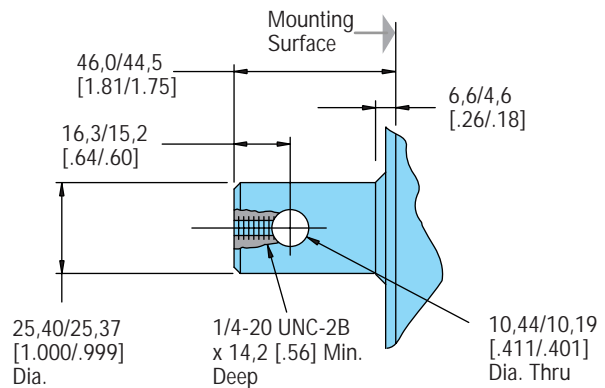

1 in. Dia. Straight Shaft with .406 Dia. Crosshole

General Purpose Motors

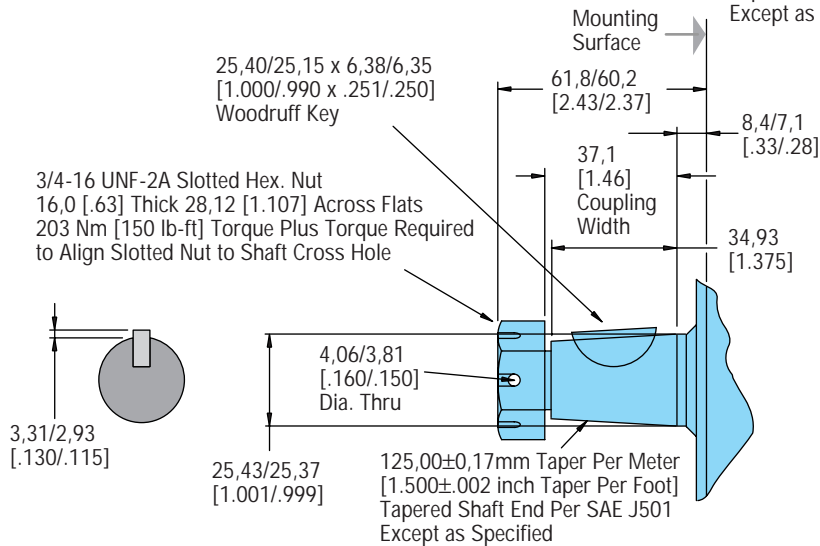
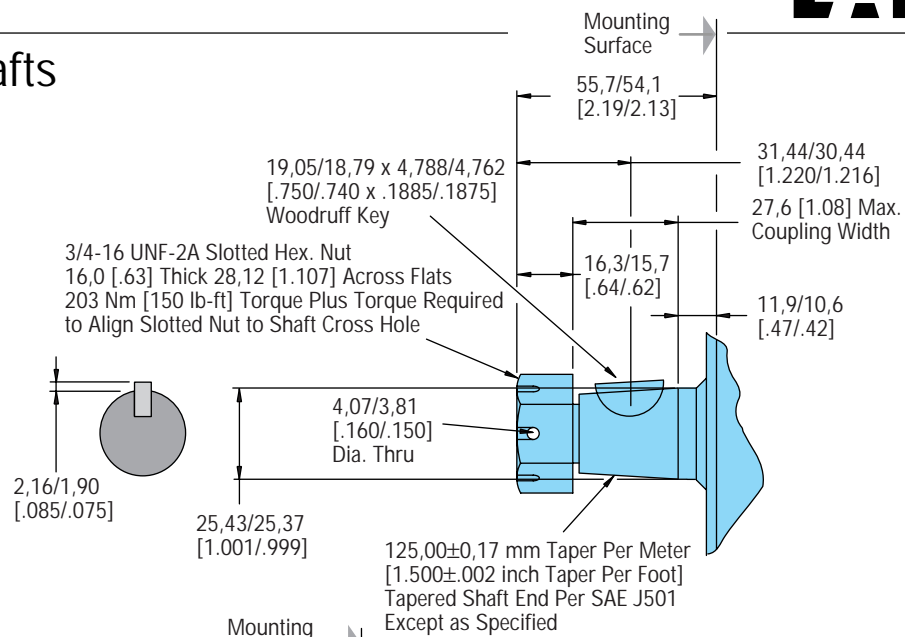
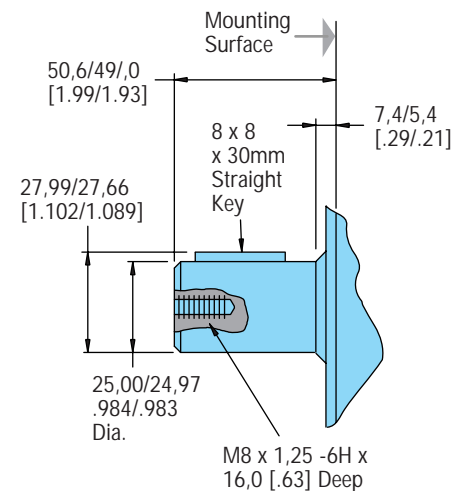
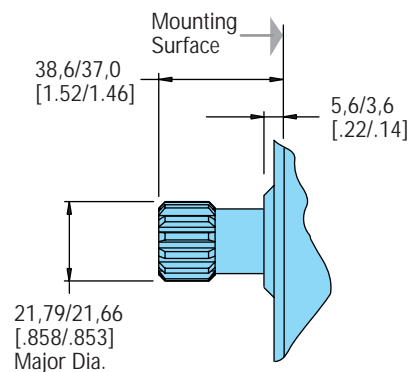
Dimensions — Shafts
R SeriesReduced Length
Tapered Shaft Option1 in. Dia. Tapered
(Reduced Length)
with Woodruff Key and Nut1 in. Dia. Tapered Shaft
with Woodruff Key and Nut25mm Dia. Straight Shaft
with 8mm Keyway7/8 in. Dia. SAE B Shaft
13 T Splined

Dimensions Ports R Series

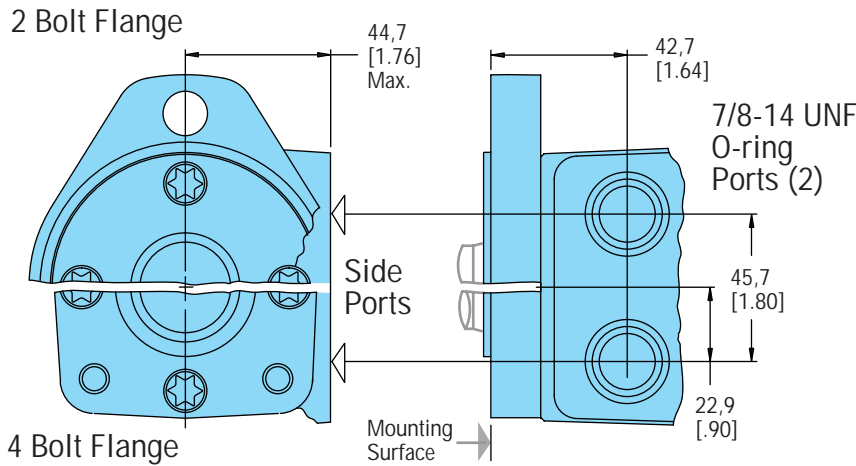

Use of Teflon Tape Sealant/Lubricant (with 1/2 14 NPTF Port Connectors only).
When using fittings with Teflon tape, be careful when taping and tightening. Over tightening or

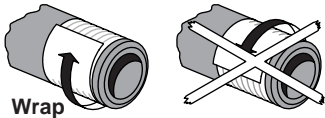

improperly taped fittings can cause damage to housing or leakage.

Use the following procedures:

- Wrap approx. 1 1/2 Turns of 13 mm [1/2 in.] wide Teflon Tape around fitting threads — start tape 2 threads up from end of fitting.
- Tighten threads to a Maximum of 34 Nm [25 lb-ft]. — **Do Not Tighten Further** —
- If fittings leak when tightened to maximum torque, either retape, reseal, or replace fittings.

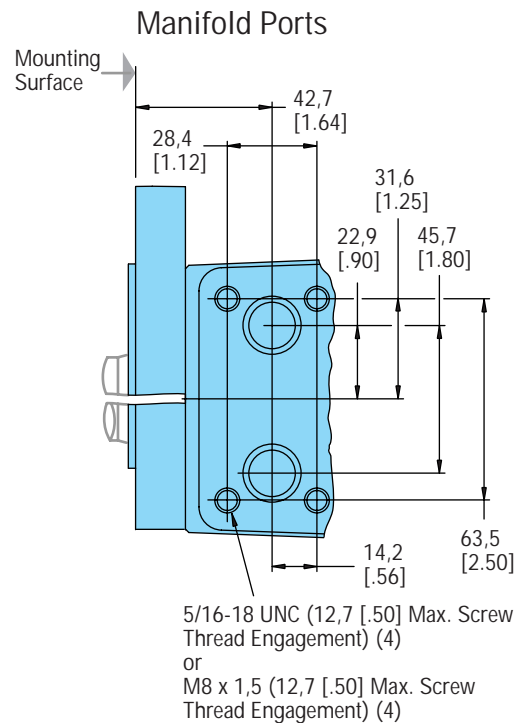
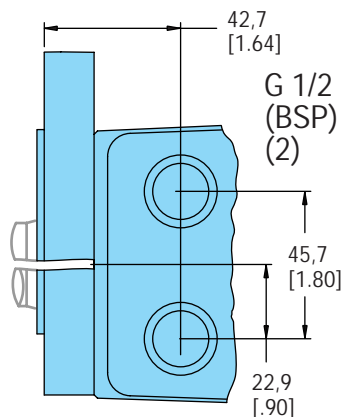
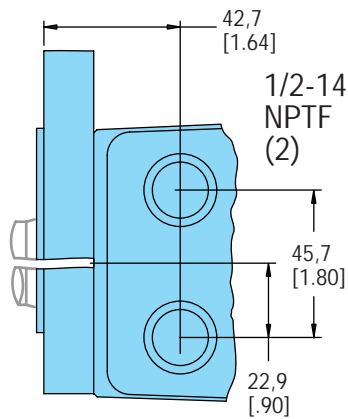

Case Pressure and Case Drain — R Series

Parallel or Series Connection

Hydraulic lines bringing pressurized fluid from the pump to the motor and return flow from the motor back to tank can be flexible or rigid. One power source and one pump can be sized to supply one motor or many motors. Furthermore, one pump and multiple motors can be connected in series or in parallel (see each type of connection shown below). When connecting the pump to the motors in series excess internal case pressure is created in the motor, this excess pressure in each motor must be ported back to tank. However, when making a parallel connection from the pump to the motors no excess case pressure will be added. Hence, using the case drain ports are not necessary. Meanwhile, take a look at the application and see if this optional case drain port can be connected to your advantage, whether it be a single motor to pump connection, multiple motors connected to pump in parallel, as well as multiple motors connected to pump in series...

...Case Drain Advantage — In addition to providing lower case pressures for motors connected in series, there are advantages for adding an external case drain line to motors with normal case pressures as well. These advantages are: Contamination Control — flushing the motor case. Cooler Systems — exiting oil draws motor heat away. Extend Motor Seal Life — maintain low case pressure with a preset restriction installed in the case drain line.

Motors ordered with case drain port will be shipped with steel hex socket plug installed in that end cap drain port.

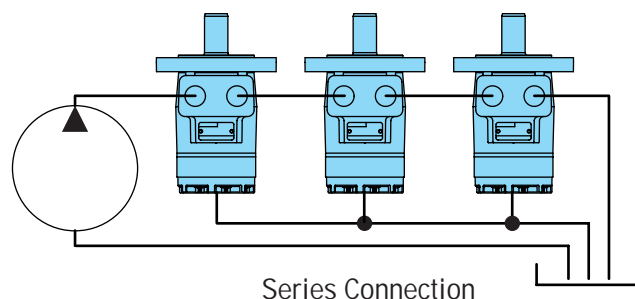
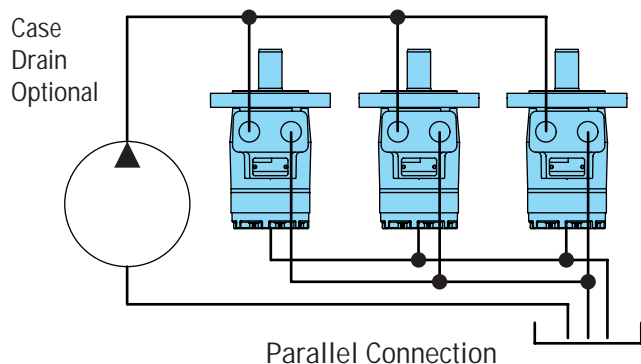

R Series with Case Drain Port —
G 1/4 (BSP) or
7/16-20 O-ring

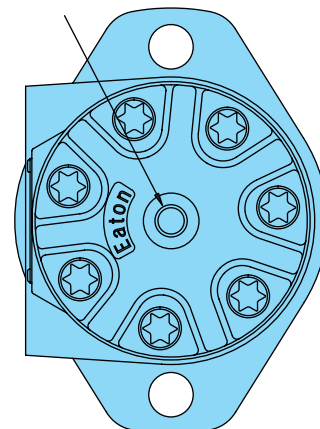

Case Pressure and Case Drain — R Series

Char-Lynn R Series motors are durable and have long life as long as the recommended case pressure is not exceeded. Allowable case pressure is highest at low shaft speeds. Consequently, motor life will be shortened if case pressure exceeds these ratings (acceptability may vary with application). Finally, determine if an external case drain is required (see case pressure seal limitation chart below — chart based on case pressure and shaft speed). In conclusion, if a case drain line is needed, connect drain line to assure that the motor will always remain full of fluid. However, a pressure restriction should be added to the case drain line, during which a motor case pressure of 3,5 Bar [50 PSI] is maintained.

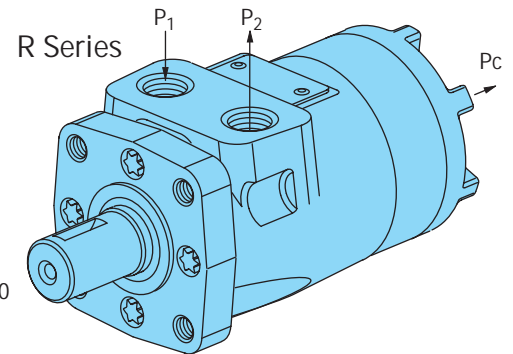
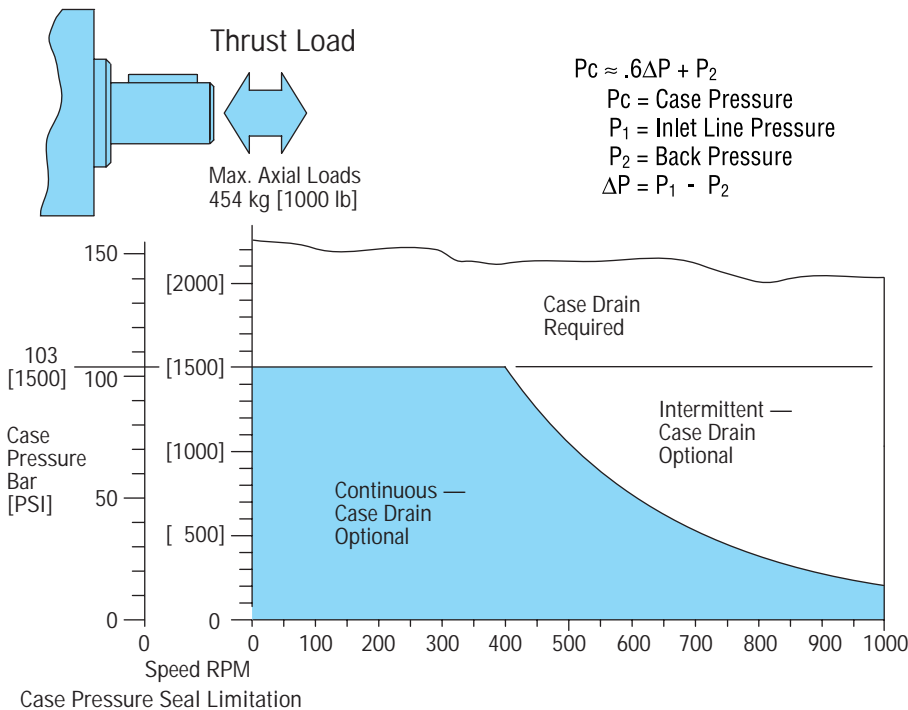

Speed Sensor R Series

Eaton has developed a speed sensor specifically designed for LSHT motors. The design is rugged and fully protected against accidental reverse polarity or short circuit hook up. A built in pull up resistor simplifies installation with control systems.

This sensor is fully compatible with mobile vehicle electrical systems and gives a reliable digital on/off signal over a wide speed range and temperature range.

Connection — standard 3 prong Weatherpack connector with 18 AWG (american wire gage) cables:

Position A (red) = power supply Position B (white) = signal output Position C (black) = common

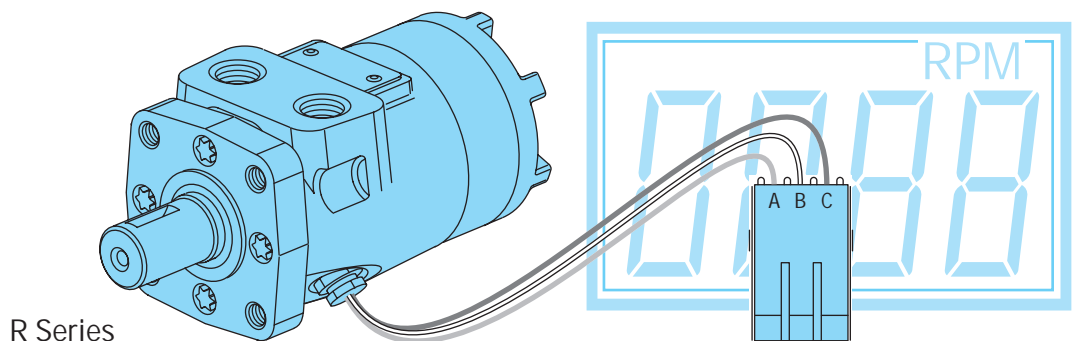

Dimensions — Mounting Options R Series

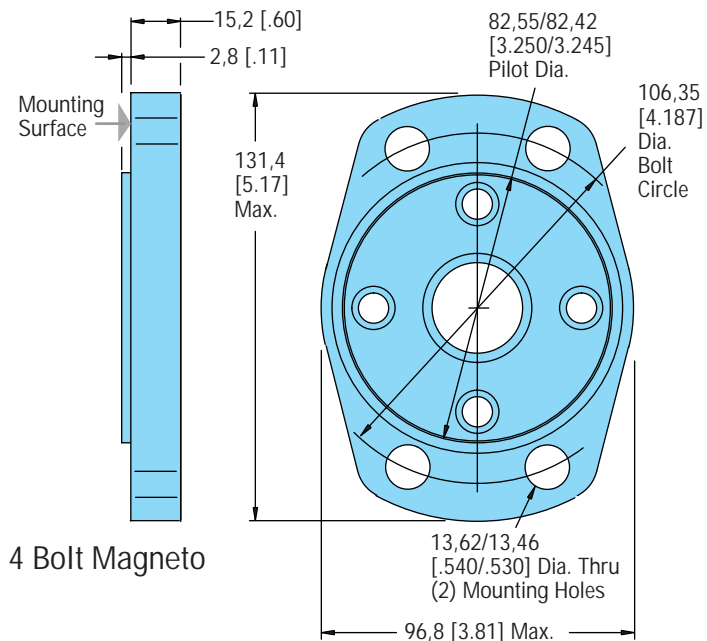

4 Bolt Magneto

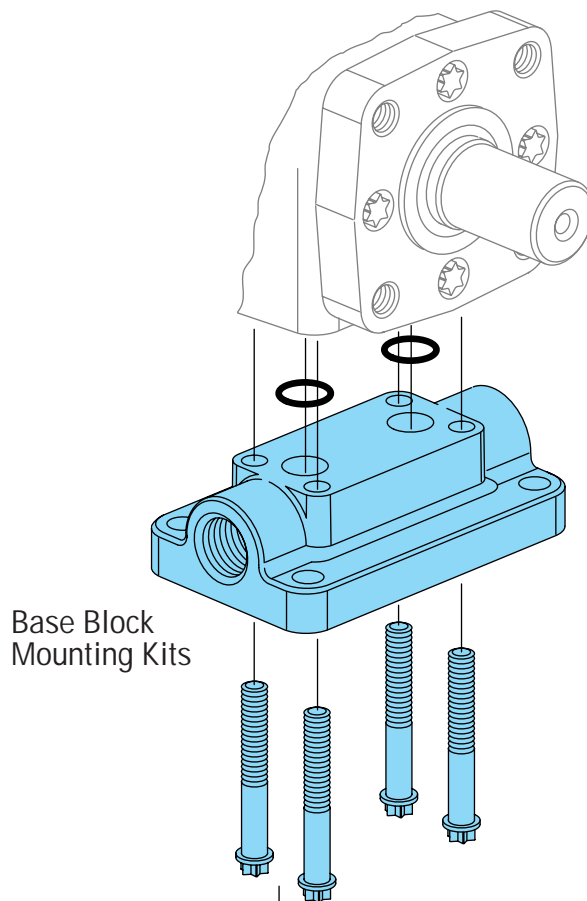

Base Block Mounting Kits

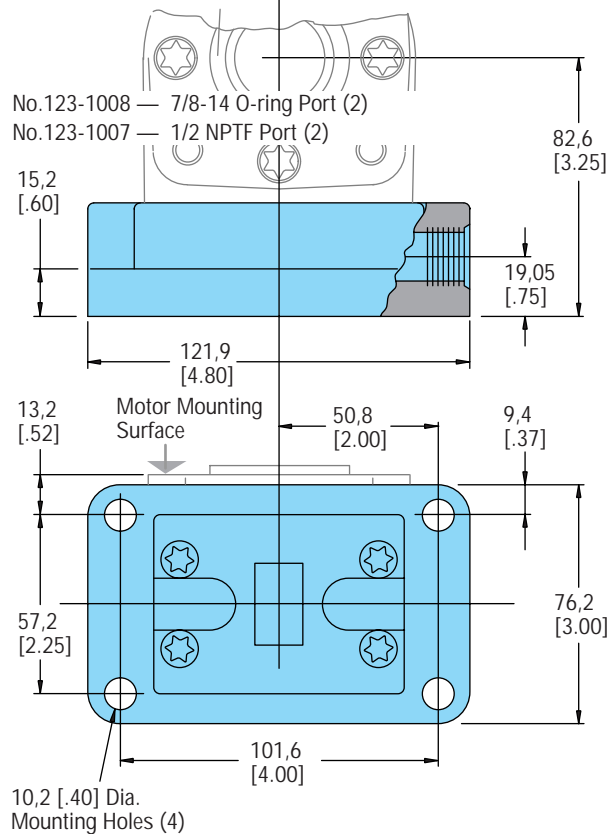

10,2 [.40] Dia. Mounting Holes (4)

Fluid Recommendations

R Series

Introduction

The ability of Eaton hydraulic components to provide the desired performance and life expectancy depends largely on the fluid used. The purpose of this section is to provide readers with the knowledge required to select the appropriate fluids for use in systems that employ Eaton hydraulic components.

One of the most important characteristics to consider when choosing a fluid to be used in a hydraulic system is viscosity. Viscosity choice is always a compromise; the fluid must be thin enough to flow easily but thick enough to seal and maintain a lubricating film between bearing and sealing surfaces. Viscosity requirements, see chart below.

Viscosity and Temperature

Fluid temperature affects viscosity. In general, as the fluid warms it gets thinner and its viscosity decreases. The opposite is true when fluid cools. When choosing a fluid, it is important to consider the start-up and operating temperatures of the hydraulic system. Generally, the fluid is thick when the hydraulic system is started. With movement, the fluid warms to a point where a cooling system begins to operate. From then on, the fluid is maintained at the temperature for which the hydraulic system was designed. In actual applications this sequence varies; hydraulic systems are used in many environments from very cold to very hot. Cooling systems also vary from very elaborate to very simple, so ambient temperature may affect operating temperature. Equipment manufacturers who use Eaton hydraulic components in their products should anticipate temperature in their designs and make the appropriate fluid recommendations to their customers.

Cleanliness

Cleanliness of the fluid in a hydraulic system is extremely important. Eaton recommends that the fluid used in its hydraulic components be maintained at ISO Cleanliness Code 18/13 per SAE J1165. This code allows a maximum of 2500 particles per milliliter greater than 5 µm and a maximum of 80 particles per milliliter greater than 15 µm. Cleanliness requirements for specific products are given in the table below.

OEM's and distributors who use Eaton hydraulic components in their products should provide for these requirements in their designs.

A reputable filter supplier can supply filter information.

Fluid Maintenance

Maintaining correct fluid viscosity and cleanliness level is essential for all hydraulic systems. Since Eaton hydraulic components are used in a wide variety of applications it is impossible for Eaton to publish a fluid maintenance schedule that would cover every situation. Field testing and monitoring are the only ways to get accurate measurements of system cleanliness. OEM's and distributors who use Eaton hydraulic components should test and establish fluid maintenance schedules for their products. These maintenance schedules should be designed to meet the viscosity and cleanliness requirements laid out in this document.

Fluid Selection

Premium grade petroleum based hydraulic fluids will provide the best performance in Eaton hydraulic components. These fluids typically contain additives that are beneficial to hydraulic systems. Eaton recommends fluids that contain anti-wear agents, rust inhibitors, anti-foaming agents, and oxidation inhibitors. Premium grade petroleum based hydraulic fluids carry an ISO VG rating.

SAE grade crankcase oils may be used in systems that employ Eaton hydraulic components, but it should be noted that these oils may not contain all of the recommended additives. This means using crankcase oils may increase fluid maintenance requirements.

Hydraulic fluids that contain V.I. (viscosity index) improvers, sometimes called multi-viscosity oils, may be used in systems that employ Eaton hydraulic components. These V.I. improved fluids are known to "shear-down" with use. This means that their actual viscosity drops below the rated value. Fluid maintenance must be increased if V.I. improved fluids are used. Automotive automatic transmission fluids contain V.I. improvers.

Synthetic fluids may be used in Eaton hydraulic components. A reputable fluid supplier can provide information on synthetic fluids. Review applications that require the use of synthetic fluids with your Eaton representative.

Product Line	Viscosity		ISO Cleanliness Requirements
	Minimum	Best Range	
R Series	70 SUS 13 cSt	100-200 SUS 20-43 cSt	18/13

Additional Notes:

- Fluids too thick to flow in cold weather start-ups will cause pump cavitation and possible damage. Motor cavitation is not a problem during cold start-ups.
- When choosing a hydraulic fluid, all the components in the system must be considered and the best viscosity range adjusted accordingly. For example, when a medium duty piston pump is combined with a Geroler motor the best viscosity range becomes 100 - 150 SUS [20 - 32 cSt] and viscosity should never fall below 70 SUS [13 cSt].

- If the natural color of the fluid has become black it is possible that an overheating problem exists.
- If the fluid becomes milky a water contamination problem may exist.
- Take fluid level reading when the system is cold.
- Contact your Eaton representative if you have specific questions about the fluid requirements of Eaton hydraulic components.

Model Code for R Series Motors

The following 16-digit coding system has been developed to identify all of the configuration options for the R Series Motor. Use this model code to specify a motor with the desired features. All 16-digits of the code must be present when ordering. You may want to photocopy the matrix below to ensure that each number is entered in the correct box.

Model Code — R Series Spool Valve Motors

1	2	3	4	5	6	7	8	9	10	11	12	13	14	15	16
M	R	0												0	0

Position 1 Product Series

M Motor

Position 2, 3 R Series

R0 R Series

Position 4, 5 Displacement cm³/r [in³/r]

02 36 [2.2]

03 49 [3.0]

04 66 [4.0]

05 80 [4.9]

06 102 [6.2]

08 131 [8.0]

10 157 [9.6]

12 195 [11.9]

15 244 [14.9]

19 306 [18.7]

05 370 [22.6]

Position 6 Mounting Flange

A 2 Bolt (Standard) 82,6 [3.25] Pilot Dia. and 13,59 [.535] Dia. Mounting Holes 106,2 [4.18] Dia. B.C.

B 4 Bolt (Standard) 44,4 [1.75] Pilot Dia. and 3/8-16 Mounting Holes 82,6 [3.25] Dia. B.C.

E 4 Bolt (Standard) 44,4 [1.75] Pilot Dia. and M10 x 1,5 Mounting Holes 82,6 [3.25] Dia. B.C.

K 4 Bolt Magneto 82,6 [3.25] Pilot Dia. and 13,59 [.535] Dia. Mounting Holes 106,2 [4.18] Dia. B.C.

Position 7, 8 Output Shaft

01 1 inch Dia. Straight with Woodruff Key and 1/4-20 Threaded hole

02 1 inch Dia. SAE 6B Splined with 1/4-20 Threaded Hole

07 1 inch Dia. Straight with 7,9 [.31] Dia. Crosshole 11,2 [.44] from End

08 1 inch Dia. Straight with 10,2 [.40] Dia. Crosshole 15,7 [.62] from End and 1/4-20 Threaded Hole

16 7/8 inch Dia. SAE B 13T Splined

18 1 inch Dia. Tapered with Woodruff Key and Nut

24 25mm Dia. Straight with 8mm Key and 8mm x 1,2 Threaded Hole

32 1 inch Dia. Straight with 10,2 [.40] Dia. Crosshole 15,7 [.62] from End and 1/4-20 Threaded Hole (Plated for Corrosion Protection)

37 1 inch Dia. Tapered with Woodruff Key and Nut, 9,52 [.375] Reduced Length

Position 9 Port Type

A 7/8-14 O-ring

B 1/2-14 NPTF

C Manifold (5/16-18 Mounting Threads)

D Manifold (M8 x 1,5 Mounting Threads)

E G 1/2 (BSP)

Position 10 Case Drain

0 No Case Drain

1 7/16-20 O-ring Port End Cap

2 G 1/4 (BSP) Port End Cap

Position 11, 12 Special Features (Hardware)

00 None

AC Viton Shaft Seal

AB Low Speed Valve

BZ Speed Sensor

Position 13 Special Features (Assembly)

0 None

1 Reverse Rotation

2 Flange Rotated 90°

Position 14 Paint/Special Packaging

0 No Paint

A Painted Low Gloss Black (Standard)

D Corrosion Protected

Position 15 Eaton Assigned Code when Applicable

0 Assigned Code

Position 16 Eaton Assigned Design Code

0 Design Code

Eaton
Fluid Power Group
Hydraulics Business USA
14615 Lone Oak Road
Eden Prairie, MN 55344
USA
Tel: 952-937-9800
Fax: 952-294-7722
www.eaton.com/hydraulics

Eaton
Fluid Power Group
Hydraulics Business Europe
Route de la Longeraie 7
1110 Morges
Switzerland
Tel: +41 (0) 21 811 4600
Fax: +41 (0) 21 811 4601

Eaton
Fluid Power Group
Hydraulics Business Asia Pacific
11th Floor Hong Kong New World Tower
300 Huaihai Zhong Road
Shanghai 200021
China
Tel: 86-21-6387-9988
Fax: 86-21-6335-3912



© 2008 Eaton Corporation
All Rights Reserved
Printed in USA
Document No. C-MOLO-TM009-E
Supersedes 11-103
December 2008

available at:
www.atphydraulik.com
info@atphydraulik.com

