



SAE Flansche aus rostfreiem Stahl





Inhaltsverzeichnis

Table of contents

Einschraubflansch SAE mit Gewinde BSP	2
BSP threaded SAE flanges.....	2
Einschraubflansch SAE mit Gewinde BSP	3
BSP threaded SAE flanges.....	3
Einschraubflansch SAE mit Gewinde NPT	4
NPT threaded SAE flanges.....	4
Einlötflansch SAE	5
Weld in SAE flanges	5
Anschweissflansch SAE	6
Weld on SAE flanges.....	6
Gegenflanschverbinder SAE mit Gewinde BSP	7
BSP threaded SAE counterflanges	7
Gegenflanschverbinder SAE zum Einlöten	8
Weld in SAE counterflanges	8
Gegenflanschverbinder SAE zum Anschweissen	9
Weld on SAE counterflanges.....	9
90° Flanschverbinder SAE mit Gewinde BSP	10
90° BSP threaded SAE flanges	10
90° Flanschverbinder SAE zum Anschweissen.....	11
90° weld in SAE flanges.....	11
SAE Verschlussflansch.....	12
Blinde flanges SAE	12
SAE Voll-Flanschverbinder.....	13
Uncut SAE split flanges	13
SAE Halbflansche.....	14
SAE split flanges.....	14
SAE Voll-Flanschverbinder als Gegenflansch mit Gewinde.....	15
Uncut SAE split flanges with metric threaded fixing holes	15
SAE Flansch-Schulter zum Vorschweissen	16
Weld on SAE adaptors	16
O-Ringe.....	17
O-Rings.....	17
Spezifikation für SAE-Flanschlochbilder.....	17
Specification for SAE flange ports	17
Abmasse für SAE-Flanschlochbilder	18
Dimenson for SAE flange ports	18
Flow rate nomogram.....	19
Nomogram	20
Chemische Material Zusammensetzung	21
Chemical material composition.....	21
INDEX.....	22



Einschraubflansch SAE mit Gewinde BSP

BSP threaded SAE flanges

mit metrischen Befestigungsschrauben

Material: rostfreier Stahl 1.4404

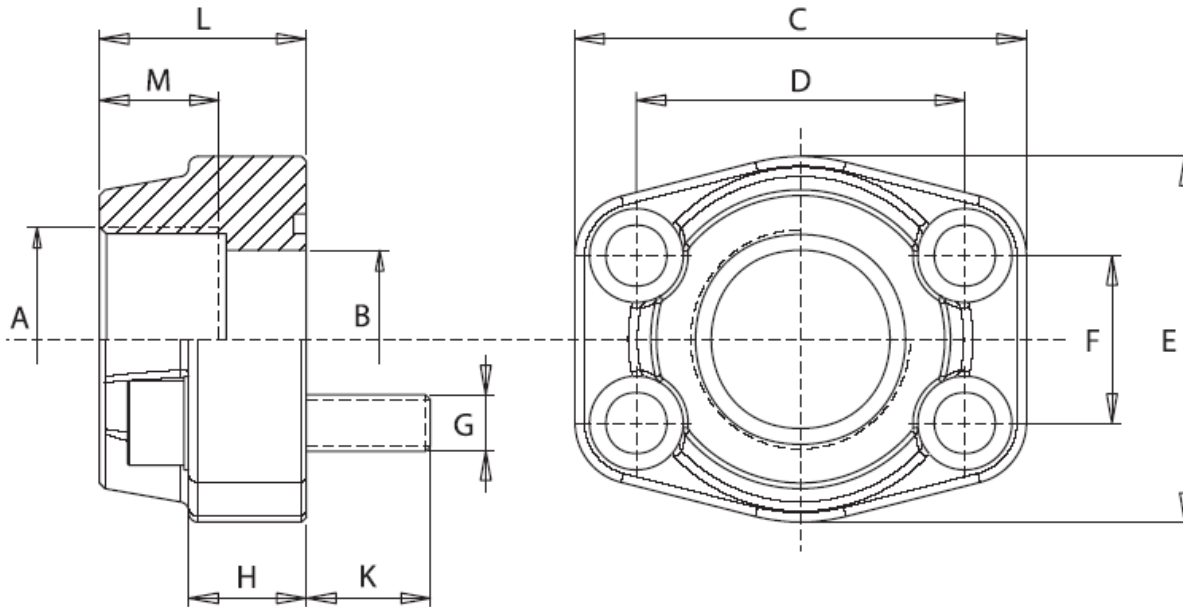

Max. Druck	TYPE	A	B	C	D	E	F	G	H	K	L	M	OR	ATP-Artikelnummer
		BSP						Metr.					O-Ring	
348	RF-C.F.S. 080-GAS-M	1/2"	13	57	38	47	17.5	M8	16	14	36	15	AN 210	070 511 206
348	RF-C.F.S. 100-GAS-M	3/4"	19	66	47.6	49	22.2	M10	18	16	36	18	AN 214	070 511 208
348	RF-C.F.S. 102-GAS-M	1"	25	71	52.4	53	26.2	M10	18	16	38	20	AN 219	070 511 212
278	RF-C.F.S. 104-GAS-M	1 1/4"	31	80	58.7	69	30.2	M10	21	18	41	22	AN 222	070 511 213
210	RF-C.F.S. 106-GAS-M	1 1/2"	38	94	70	77	35.7	M12	25	18	44	24	AN 225	070 511 216
210	RF-C.F.S. 108-GAS-M	2"	50	103	77.8	89	42.9	M12	25	18	45	26	AN 228	070 511 221
175	RF-C.F.S. 110-GAS-M	2 1/2"	63	115	89	101	50.8	M12	25	18	50	30	AN 232	070 511 226
138	RF-C.F.S. 112-GAS-M	3"	73	135	106.4	124	62	M16	27	25	50	30	AN 237	070 511 231
35	RF-C.F.S. 114-GAS-M	3 1/2"	89	152	120.7	136	70	M16	27	25	50	30	AN 241	070 511 236
35	RF-C.F.S. 116-GAS-M	4"	99	162	130	146	77.8	M16	27	25	50	30	AN 245	070 511 241

Max. Druck	TYPE	A	B	C	D	E	F	G	H	K	L	M	OR	ATP-Artikelnummer
		BSP						Metr.					O-Ring	
420	RF-C.F.S. 401-GAS-M	3/8"	13	57	40.5	47	18.2	M8	16	14	36	13	AN 210	070 530 204
420	RF-C.F.S. 402-GAS-M	3/4"	19	71	50.8	53	23.8	M10	18	16	36	18	AN 214	070 530 207
420	RF-C.F.S. 403-GAS-M	1"	25	80	57.2	69	27.8	M12	20	19	44	20	AN 219	070 530 210
420	RF-C.F.S. 404-GAS-M	1 1/4"	31	94	66.6	77	31.8	M14	27	22	44	22	AN 222	070 530 213
420	RF-C.F.S. 405-GAS-M	1 1/2"	38	106	79.3	89	36.5	M16	30	24	51	24	AN 225	070 530 216
420	RF-C.F.S. 406-GAS-M	2"	50	135	96.8	116	44.5	M20	37	32	70	33	AN 228	070 530 220



Einschraubflansch SAE mit Gewinde BSP

BSP threaded SAE flanges

mit UNC Befestigungsschrauben

Material: rostfreier Stahl 1.4404

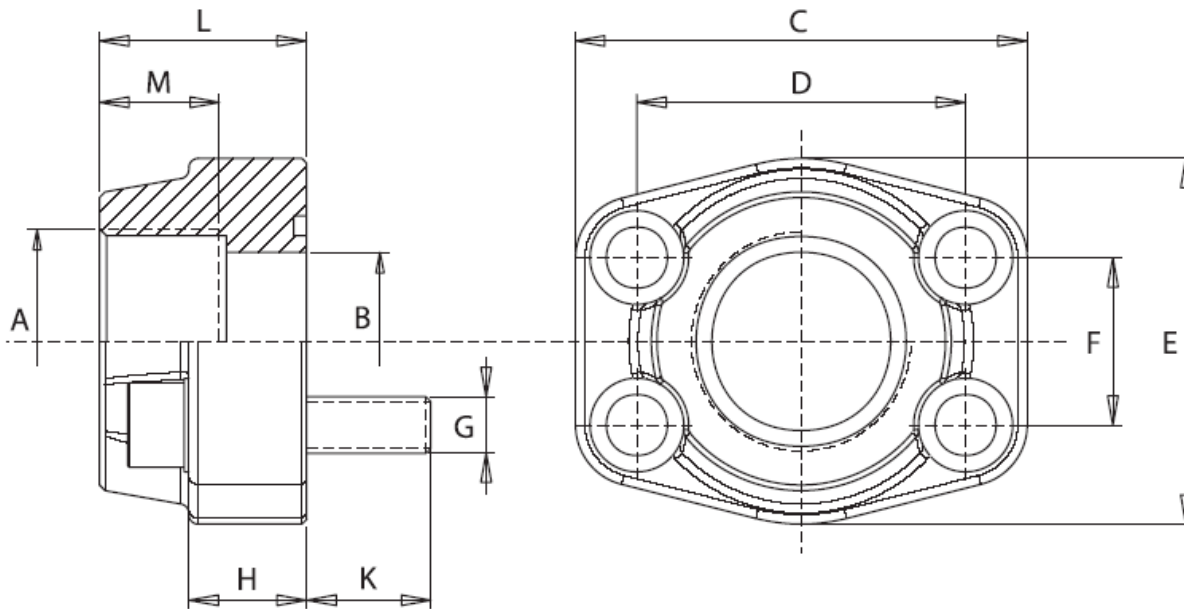

Max. Druck	TYPE	A	B	C	D	E	F	G	H	K	L	M	OR	ATP-
		BSP						UNC					O-Ring	Artikelnummer
348	RF-C.F.S. 080-GAS-U	1/2"	13	57	38	47	17.5	5/16"	16	14	36	15	AN 210	070 511 256
348	RF-C.F.S. 100-GAS-U	3/4"	19	66	47.6	49	22.2	3/8"	18	16	36	18	AN 214	070 511 258
348	RF-C.F.S. 102-GAS-U	1"	25	71	52.4	53	26.2	3/8"	18	16	38	20	AN 219	070 511 259
278	RF-C.F.S. 104-GAS-U	1 1/4"	31	80	58.7	69	30.2	7/16"	21	18	41	22	AN 222	070 511 262
210	RF-C.F.S. 106-GAS-U	1 1/2"	38	94	70	77	35.7	1/2"	25	18	44	24	AN 225	070 511 266
210	RF-C.F.S. 108-GAS-U	2"	50	103	77.8	89	42.9	1/2"	25	18	45	26	AN 228	070 511 271
175	RF-C.F.S. 110-GAS-U	2 1/2"	63	115	89	101	50.8	1/2"	25	18	50	30	AN 232	070 511 276
138	RF-C.F.S. 112-GAS-U	3"	73	135	106.4	124	62	5/8"	27	25	50	30	AN 237	070 511 278
35	RF-C.F.S. 114-GAS-U	3 1/2"	89	152	120.7	136	70	5/8"	27	25	50	30	AN 241	070 511 281
35	RF-C.F.S. 116-GAS-U	4"	99	162	130	146	77.8	5/8"	27	25	50	30	AN 245	070 511 286

Max. Druck	TYPE	A	B	C	D	E	F	G	H	K	L	M	OR	ATP-
		BSP						UNC					O-Ring	Artikelnummer
420	RF-C.F.S. 401-GAS-U	3/8"	13	57	40.5	47	18.2	5/16"	16	14	36	13	AN 210	070 531 254
420	RF-C.F.S. 402-GAS-U	3/4"	19	71	50.8	53	23.8	3/8"	18	16	36	18	AN 214	070 531 258
420	RF-C.F.S. 403-GAS-U	1"	25	80	57.2	69	27.8	7/16"	20	19	44	20	AN 219	070 531 262
420	RF-C.F.S. 404-GAS-U	1 1/4"	31	94	66.6	77	31.8	1/2"	27	22	44	22	AN 222	070 531 263
420	RF-C.F.S. 405-GAS-U	1 1/2"	38	106	79.3	89	36.5	5/8"	30	24	51	24	AN 225	070 531 266
420	RF-C.F.S. 406-GAS-U	2"	50	135	96.8	116	44.5	3/4"	37	32	70	33	AN 228	070 531 271



Einschraubflansch SAE mit Gewinde NPT

NPT threaded SAE flanges

Material: rostfreier Stahl 1.4404

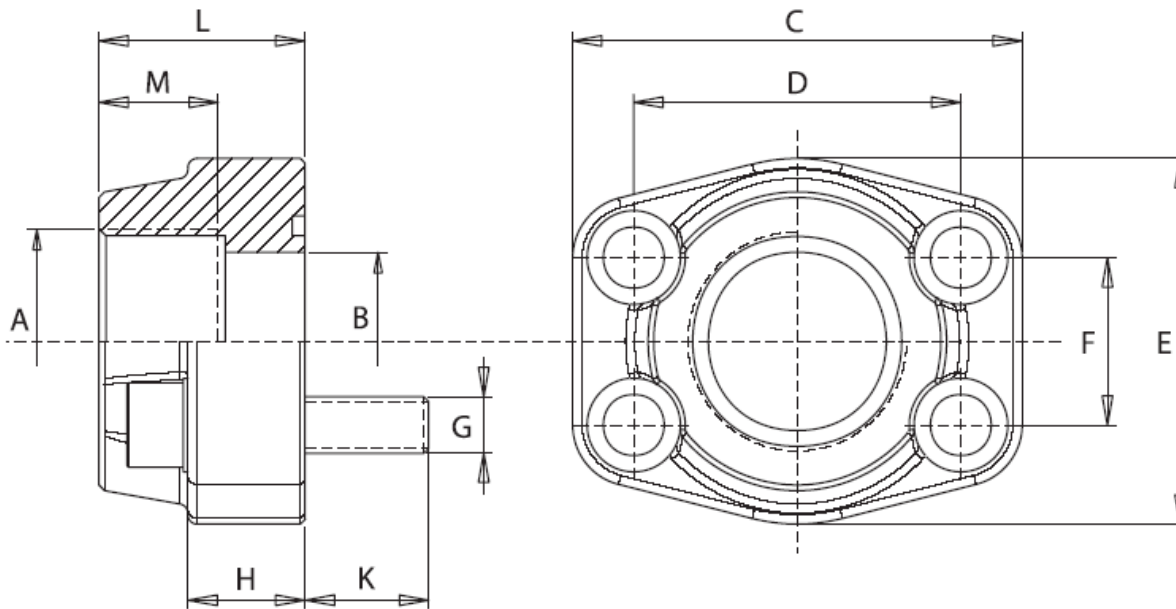

Max. Druck	TYPE	A	B	C	D	E	F	G	H	K	L	M	OR	ATP Artikelnummer
		NPT						Metr.					O-Ring	
348	RF-C.F.S. 080-NPT-M	1/2"	13	57	38.1	47	17.5	M8	16	14	36	19	AN 210	070 511 306
348	RF-C.F.S. 100-NPT-M	3/4"	19	66	47.6	49	22.3	M10	18	16	36	19	AN 214	070 511 308
348	RF-C.F.S. 102-NPT-M	1"	25	71	52.4	53	26.2	M10	18	16	38	19	AN 219	070 511 311
278	RF-C.F.S. 104-NPT-M	1 1/4"	31	80	58.7	69	30.2	M10	21	18	41	22	AN 222	070 511 313
210	RF-C.F.S. 106-NPT-M	1 1/2"	38	94	70	77	35.7	M12	25	18	44	24	AN 225	070 511 316
210	RF-C.F.S. 108-NPT-M	2"	50	103	77.8	89	42.9	M12	25	18	45	26	AN 228	070 511 321

Max. Druck	TYPE	A	B	C	D	E	F	G	H	K	L	M	OR	ATP Artikelnummer
		NPT						Metr.					O-Ring	
420	RF-C.F.S. 401-NPT-M	3/8"	13	57	40.5	47	18.2	M8	16	14	36	19	AN 210	070 531 304
420	RF-C.F.S. 401-NPT-M	1/2"	13	57	40.5	47	18.2	M8	16	14	36	19	AN 210	
420	RF-C.F.S. 402-NPT-M	3/4"	19	71	50.8	53	23.8	M10	19	16	36	22	AN 214	070 531 308
420	RF-C.F.S. 403-NPT-M	1"	25	80	57.2	69	27.8	M12	24	19	44	24	AN 219	070 531 311
420	RF-C.F.S. 404-NPT-M	1 1/4"	31	94	66.6	77	31.8	M14	27	22	44	25	AN 222	070 531 313
420	RF-C.F.S. 405-NPT-M	1 1/2"	38	106	79.3	89	36.5	M16	30	24	51	28	AN 225	070 531 316



Einlötlansch SAE Weld in SAE flanges

Material: rostfreier Stahl 1.4404

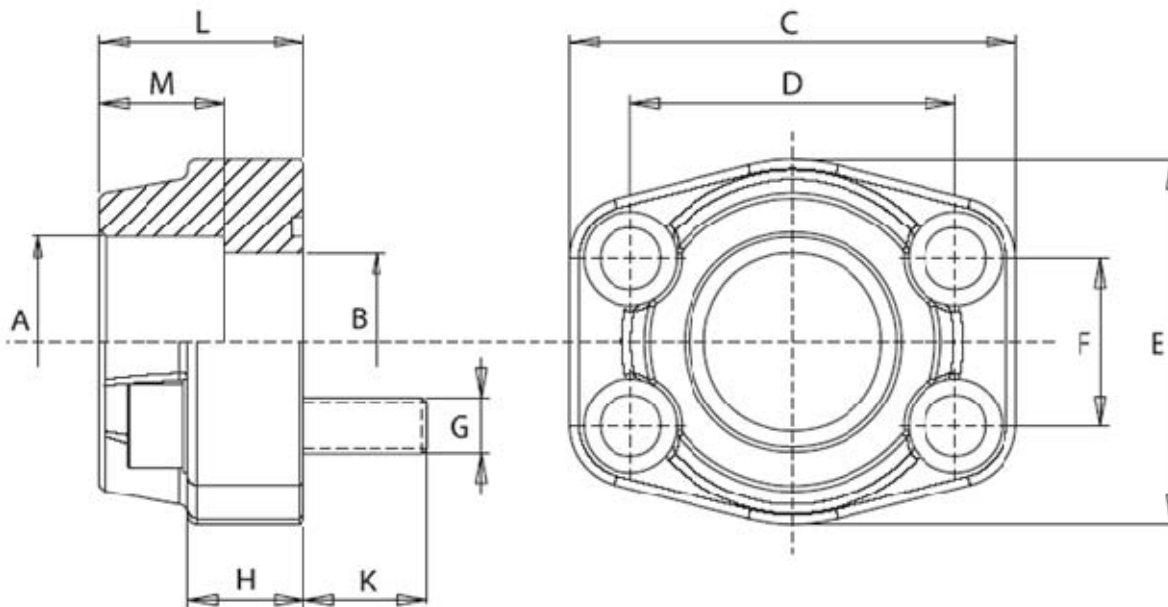

Max. Druck	TYPE	A		B	C	D	E	F	G	H	K	L	M	OR O-Ring	ATP Artikelnummer
		Metr.													
348	RF-C.F.S. 080-S-M	21.6	1/2"	13	57	38.1	47	17.5	M8	16	14	36	18	AN 210	070 513 206
348	RF-C.F.S. 100-S-M	27.2	3/4"	19	66	47.6	49	22.3	M10	18	16	36	18	AN 214	070 513 208
348	RF-C.F.S. 102-S-M	34.1	1"	25	70	52.4	53	26.2	M10	18	16	38	18	AN 219	070 513 212
278	RF-C.F.S. 104-S-M	42.8	1 1/4"	31	80	58.7	69	30.2	M10	21	18	41	20	AN 222	070 513 213
210	RF-C.F.S. 106-S-M	48.6	1 1/2"	38	94	69.9	77	35.7	M12	25	18	44	22	AN 225	070 513 216
210	RF-C.F.S. 108-S-M	61	2"	50	103	77.8	89	42.9	M12	25	18	45	24	AN 228	070 513 221
175	RF-C.F.S. 110-S-M	76.6	2 1/2"	63	115	88.9	101	50.8	M12	25	18	50	28	AN 232	070 513 226
138	RF-C.F.S. 112-S-M	90.5	3"	73	135	106.4	124	61.9	M16	27	25	50	28	AN 237	070 513 231
35	RF-C.F.S. 114-S-M	103	3 1/2"	89	153	120.7	136	69.9	M16	27	25	50	28	AN 241	070 513 236
35	RF-C.F.S. 116-S-M	115.3	4"	99	163	130.2	147	77.8	M16	27	25	50	28	AN 245	070 513 241

Max. Druck	TYPE	A		B	C	D	E	F	G	H	K	L	M	OR O-Ring	ATP Artikelnummer
		Metr.													
420	RF-C.F.S. 401-S-M	17.5	3/8"	13	57	40.5	47	18.2	M8	16	14	36	18	AN 210	070 533 204
420	RF-C.F.S. 402-S-M	27.2	3/4"	19	71	50.8	53	23.8	M10	19	14	36	20	AN 214	070 533 208
420	RF-C.F.S. 403-S-M	34.1	1"	25	80	57.2	66	27.8	M12	24	18	44	22	AN 219	070 533 212
420	RF-C.F.S. 404-S-M	42.8	1 1/4"	31	94	66.6	77	31.8	M14	27	18	44	22	AN 222	070 533 213
420	RF-C.F.S. 405-S-M	48.6	1 1/2"	38	106	79.3	89	36.5	M16	30	18	51	24	AN 225	070 533 216
420	RF-C.F.S. 406-S-M	61	2"	50	135	96.8	116	44.5	M20	37	22	70	25	AN 228	070 533 221



Anschweisflansch SAE

Weld on SAE flanges

Material: rostfreier Stahl 1.4404

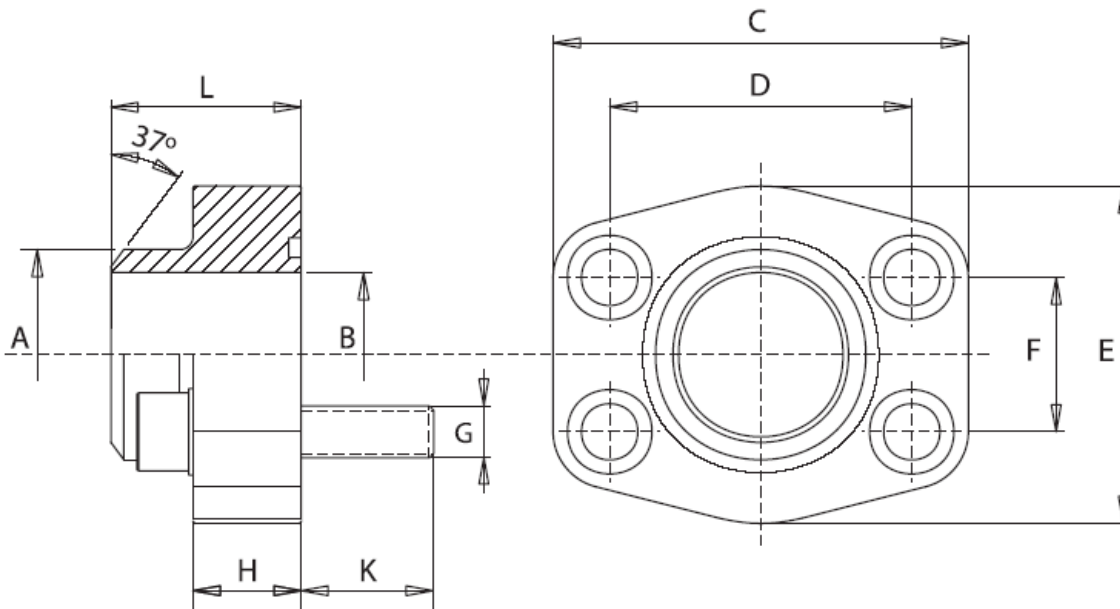

Max. Druck	TYPE	A		B	C	D	E	F	G	H	K	L	OR	ATP Artikelnummer
													O-Ring	
348	RF-C.F.S. 080-ST-M	21.6	1/2"	13	57	38.1	47	17.5	M8	16	14	36	AN 210	070 514 206
348	RF-C.F.S. 100-ST-M	27.2	3/4"	19	66	47.6	49	22.3	M10	18	16	36	AN 214	070 514 208
348	RF-C.F.S. 102-ST-M	34.5	1"	25	71	52.4	53	26.2	M10	18	16	38	AN 219	070 514 209
278	RF-C.F.S. 104-ST-M	42.8	1 1/4"	31	80	58.7	69	30.2	M10	21	18	41	AN 222	070 514 212
210	RF-C.F.S. 106-ST-M	48.6	1 1/2"	38	94	69.9	77	35.7	M12	25	18	44	AN 225	070 514 216
210	RF-C.F.S. 108-ST-M	61	2"	50	103	77.8	89	42.9	M12	25	18	45	AN 228	070 514 221
175	RF-C.F.S. 110-ST-M	76.6	2 1/2"	63	115	88.9	101	50.8	M12	25	18	50	AN 232	070 514 226
138	RF-C.F.S. 112-ST-M	89	3"	73	135	106.4	124	61.9	M16	27	25	50	AN 237	070 514 231
35	RF-C.F.S. 114-ST-M	103	3 1/2"	89	153	120.7	137	69.9	M16	27	25	50	AN 241	070 514 236
35	RF-C.F.S. 116-ST-M	115	4"	99	163	130.2	147	77.8	M16	27	25	50	AN 245	070 514 241

Max. Druck	TYPE	A		B	C	D	E	F	G	H	K	L	OR	ATP Artikelnummer
													O-Ring	
420	RF-C.F.S. 401-ST-M	17.5	3/8"	10	57	40.5	47	18.2	M8	16	14	36	AN 210	070 534 204
420	RF-C.F.S. 402-ST-M	27.2	3/4"	18	71	50.8	53	23.8	M10	19	16	36	AN 214	070 534 208
420	RF-C.F.S. 403-ST-M	34.5	1"	22	80	57.2	66	27.8	M12	24	19	44	AN 219	070 534 209
420	RF-C.F.S. 404-ST-M	42.8	1 1/4"	28	94	66.6	77	31.8	M14	27	22	44	AN 222	070 534 212
420	RF-C.F.S. 405-ST-M	48.6	1 1/2"	32	106	79.3	89	36.5	M16	30	24	51	AN 225	070 534 216
420	RF-C.F.S. 406-ST-M	61	2"	41	135	96.8	116	44.5	M20	37	32	70	AN 228	070 534 221



Gegenflanschverbinder SAE mit Gewinde BSP

BSP threaded SAE counterflanges

Material: rostfreier Stahl 1.4404

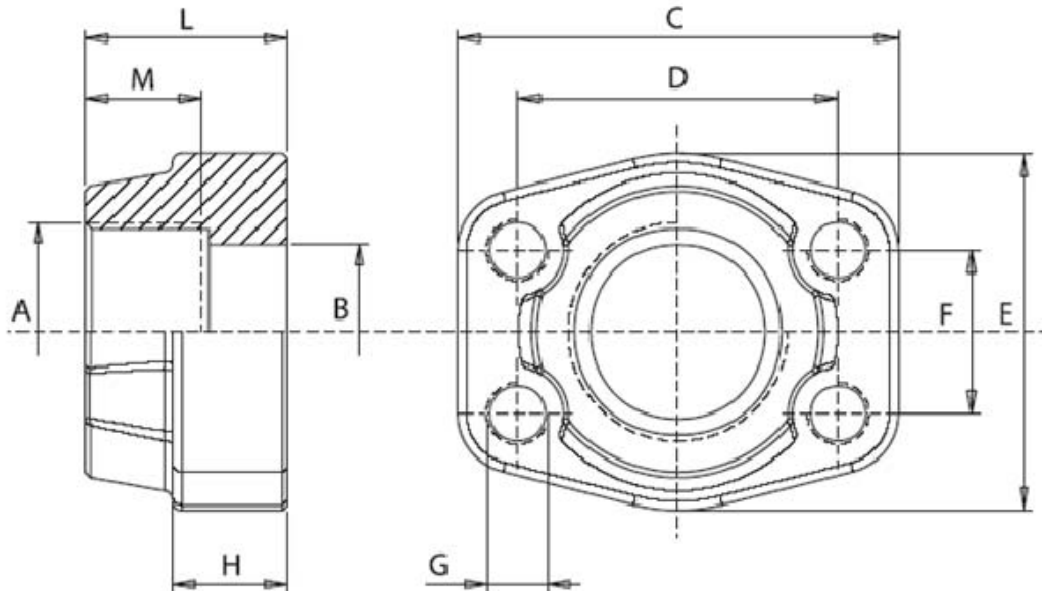

Max. Druck	TYPE	A	B	C	D	E	F	G	H	L	M	ATP Artikelnummer
		BSP						Metr.				
348	RF-C. 080-GAS-F-F-M	1/2"	13	57	38.1	47	17.5	M8	16	36	19	
348	RF-C. 100-GAS-F-F-M	3/4"	19	66	47.6	49	22.3	M10	18	36	19	
348	RF-C. 102-GAS-F-F-M	1"	25	71	52.4	53	26.2	M10	18	38	19	
278	RF-C. 104-GAS-F-F-M	1 1/4"	31	80	58.7	69	30.2	M10	21	41	22	
210	RF-C. 106-GAS-F-F-M	1 1/2"	38	94	69.9	77	35.7	M12	25	44	24	
210	RF-C. 108-GAS-F-F-M	2"	50	103	77.8	89	42.9	M12	25	45	26	
175	RF-C. 110-GAS-F-F-M	2 1/2"	63	115	88.9	101	50.8	M12	25	50	30	
138	RF-C. 112-GAS-F-F-M	3"	73	135	106.4	124	61.9	M16	27	50	34	
35	RF-C. 114-GAS-F-F-M	3 1/2"	89	152	120.7	136	69.9	M16	27	50	27	
35	RF-C. 116-GAS-F-F-M	4"	99	162	130.2	146	77.8	M16	27	50	30	

Max. Druck	TYPE	A	B	C	D	E	F	G	H	L	M	ATP Artikelnummer
		BSP						Metr.				
420	RF-C. 401-GAS-F-F-M	3/8"	13	57	40.5	47	18.2	M8	16	36	19	
420	RF-C. 402-GAS-F-F-M	3/4"	19	71	50.8	53	23.8	M10	19	36	22	
420	RF-C. 403-GAS-F-F-M	1"	25	80	57.2	69	27.8	M12	24	44	24	
420	RF-C. 404-GAS-F-F-M	1 1/4"	31	94	66.6	77	31.8	M14	27	44	25	
420	RF-C. 405-GAS-F-F-M	1 1/2"	38	106	79.3	89	36.5	M16	30	51	28	
420	RF-C. 406-GAS-F-F-M	2"	50	135	96.8	116	44.5	M20	37	70	33	



Gegenflanschverbinder SAE zum Einlöten Weld in SAE counterflanges

Material: rostfreier Stahl 1.4404

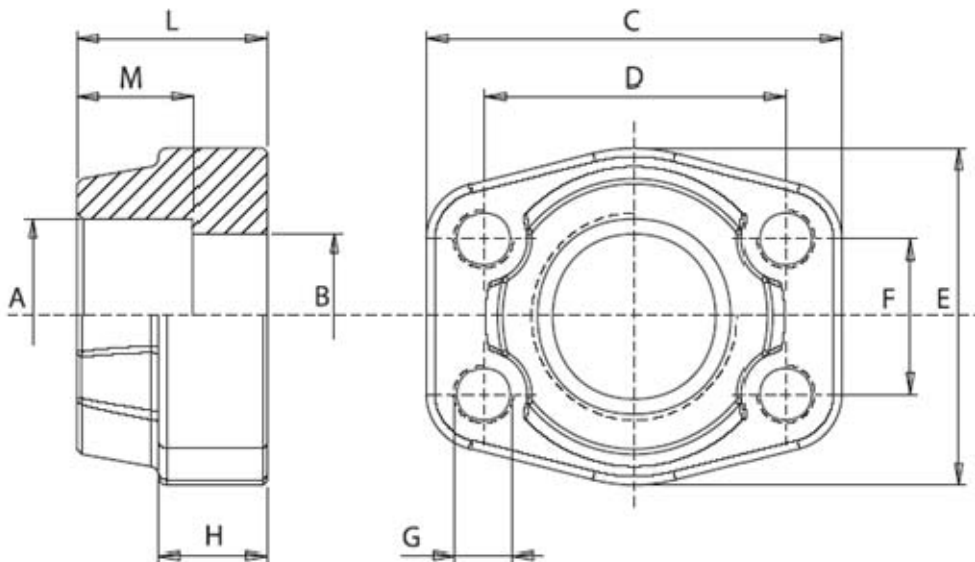

Max. Druck	TYPE	A		B	C	D	E	F	G	H	L	M	ATP Artikelnummer
		Metr.											
348	RF-M-C. 080-S-F-F	17.5	3/8"	13	57	38.1	47	17.5	M8	16	36	18	070 513 806
348	RF-M-C. 100-S-F-F	27.2	3/4"	19	66	47.6	49	22.3	M10	18	36	18	070 513 808
348	RF-M-C. 102-S-F-F	34.1	1"	25	70	52.4	53	26.2	M10	18	38	18	070 513 812
278	RF-M-C. 104-S-F-F	42.8	1 1/4"	31	80	58.7	69	30.2	M10	21	41	20	070 513 813
210	RF-M-C. 106-S-F-F	48.6	1 1/2"	38	94	69.9	77	35.7	M12	25	44	22	070 513 816
210	RF-M-C. 108-S-F-F	61	2"	50	103	77.8	89	42.9	M12	25	45	24	070 513 821
175	RF-M-C. 110-S-F-F	76.6	2 1/2"	63	115	88.9	101	50.8	M12	25	50	28	070 513 826
138	RF-M-C. 112-S-F-F	90.5	3"	73	135	106.4	124	61.9	M16	27	50	28	070 513 831
35	RF-M-C. 114-S-F-F	103	3 1/2"	89	153	120.7	137	69.9	M16	27	50	28	070 513 836
35	RF-M-C. 116-S-F-F	115.3	4"	99	163	130.2	147	77.8	M16	27	50	28	070 513 841

Max. Druck	TYPE	A		B	C	D	E	F	G	H	L	M	ATP Artikelnummer
		Metr.											
420	RF-M-C. 401-S-F-F	17.5	3/8"	13	57	40.5	47	18.2	M8	16	36	18	070 533 804
420	RF-M-C. 402-S-F-F	27.2	3/4"	19	71	50.8	53	23.8	M10	19	36	20	070 533 808
420	RF-M-C. 403-S-F-F	34.1	1"	25	80	57.2	66	27.8	M12	24	44	22	070 533 812
420	RF-M-C. 404-S-F-F	42.8	1 1/4"	31	94	66.6	77	31.8	M14	27	44	22	070 533 813
420	RF-M-C. 405-S-F-F	48.6	1 1/2"	38	106	79.3	89	36.5	M16	30	51	24	070 533 816
420	RF-M-C. 406-S-F-F	61	2"	50	135	96.8	116	44.5	M20	37	70	25	070 533 821



Gegenflanschverbinder SAE zum Anschweißen Weld on SAE counterflanges

Material: rostfreier Stahl 1.4404

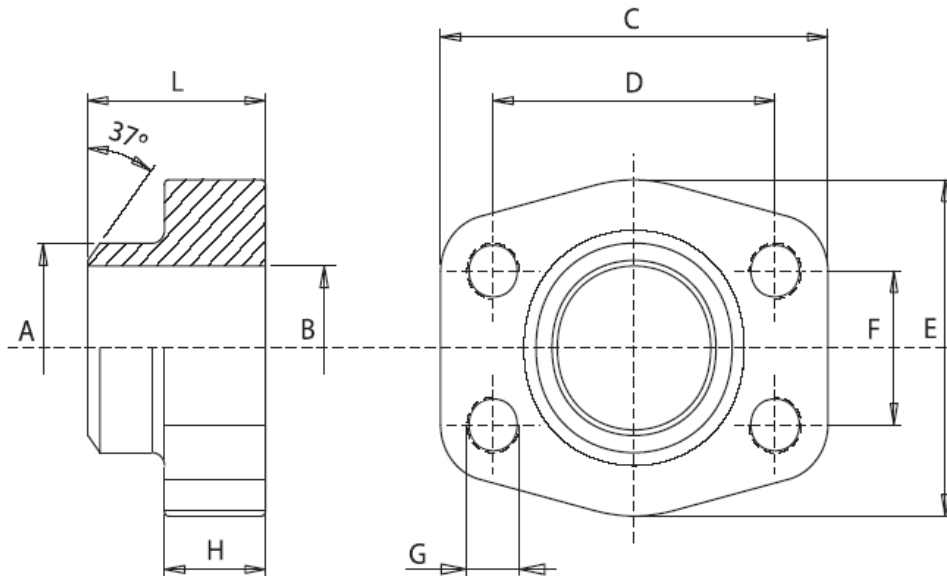

Max. Druck	TYPE	A		B	C	D	E	F	G	H	L	ATP Artikelnummer
348	RF-C. 080-ST-F-F-M	17.5	3/8"	10	57	38.1	47	17.5	M8	16	36	070 514 806
348	RF-C. 100-ST-F-F-M	27.2	3/4"	19	66	47.6	49	22.3	M10	18	36	070 514 808
348	RF-C. 102-ST-F-F-M	34.5	1"	25	71	52.4	53	26.2	M10	18	38	070 514 812
278	RF-C. 104-ST-F-F-M	42.8	1 1/4"	31	80	58.7	69	30.2	M10	21	41	070 514 813
210	RF-C. 106-ST-F-F-M	48.6	1 1/2"	38	94	69.9	77	35.7	M12	25	44	070 514 816
210	RF-C. 108-ST-F-F-M	61	2"	50	103	77.8	89	42.9	M12	25	45	070 514 823
175	RF-C. 110-ST-F-F-M	76.6	2 1/2"	63	115	88.9	101	50.8	M12	25	50	070 514 826
138	RF-C. 112-ST-F-F-M	89	3"	73	135	106.4	124	61.9	M16	27	50	070 514 831
35	RF-C. 114-ST-F-F-M	103	3 1/2"	89	153	120.7	137	69.9	M16	27	50	070 514 836
35	RF-C. 116-ST-F-F-M	115	4"	99	163	130.2	147	77.8	M16	27	50	070 514 841

Max. Druck	TYPE	A		B	C	D	E	F	G	H	L	ATP Artikelnummer
420	RF-C. 401-ST-F-F-M	17.5	3/8"	10	57	40.5	47	18.2	M8	16	36	070 534 804
420	RF-C. 402-ST-F-F-M	27.2	3/4"	18	71	50.8	53	23.8	M10	19	36	070 534 808
420	RF-C. 403-ST-F-F-M	34.5	1"	22	80	57.2	66	27.8	M12	24	44	070 534 812
420	RF-C. 404-ST-F-F-M	42.8	1 1/4"	28	94	66.6	77	31.8	M14	27	44	070 534 813
420	RF-C. 405-ST-F-F-M	48.6	1 1/2"	32	106	79.3	89	36.5	M16	30	51	070 534 816
420	RF-C. 406-ST-F-F-M	61	2"	41	135	96.8	116	44.5	M20	37	70	070 534 821



90° Flanschverbinder SAE mit Gewinde BSP

90° BSP threaded SAE flanges

Material: rostfreier Stahl 1.4404

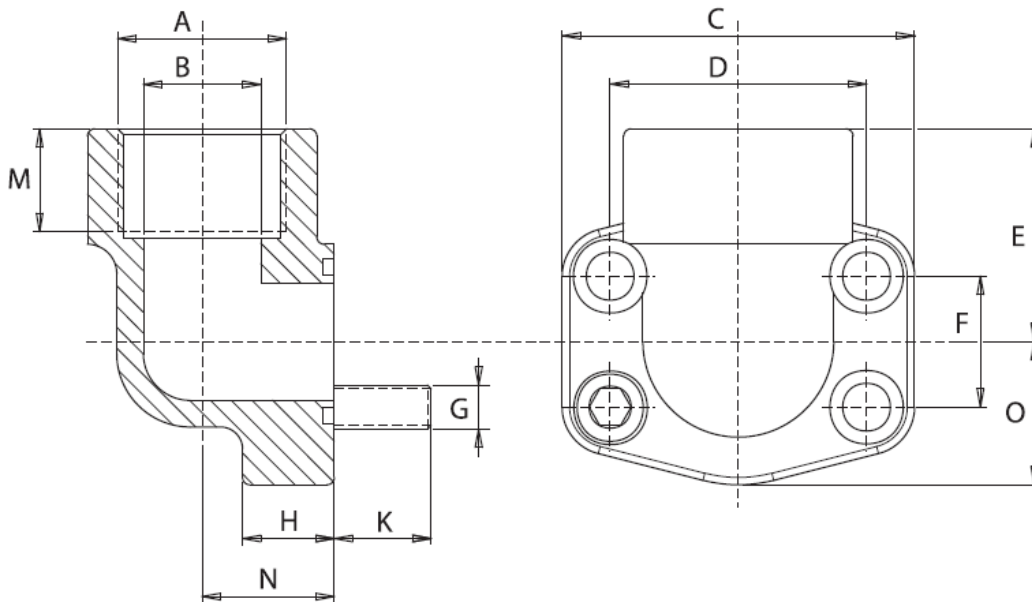

Max. Druck	TYPE	A	B	C	D	E	F	G	H	K	M	O	OR	ATP Artikelnummer
								Metr.					O-Ring	
348	RF-F.S. 300.90°-GAS-M	3/4"	19	68	47.6	38	22.3	M10	18	15	19	25	AN 214	070 511 608
348	RF-F.S. 302.90°-GAS-M	1"	25	74	52.4	41	26.2	M10	19	15	19	27	AN 219	070 511 612
278	RF-F.S. 304.90°-GAS-M	1 1/4"	31	81	58.7	50	30.2	M10	22	17	22	34	AN 222	070 511 613
210	RF-F.S. 306.90°-GAS-M	1 1/2"	38	95	69.9	58	35.7	M12	25	18	24	39	AN 225	070 511 616
210	RF-F.S. 308.90°-GAS-M	2"	50	105	77.8	65	42.9	M12	25	18	26	44	AN 228	070 511 621

Max. Druck	TYPE	A	B	C	D	E	F	G	H	K	M	O	OR	ATP Artikelnummer
								Metr.					O-Ring	
420	RF-F.S. 600.90°-GAS-M	3/4"	19	72	50.8	41	23.8	M10	20	15	22	27	AN 214	070 531 608
420	RF-F.S. 602.90°-GAS-M	1"	25	82	57.2	50	27.8	M12	24	19	24	34	AN 219	070 531 612
420	RF-F.S. 604.90°-GAS-M	1 1/4"	31	95	66.6	58	31.8	M14	25	21	25	39	AN 222	070 531 613
420	RF-F.S. 606.90°-GAS-M	1 1/2"	38	110	79.3	65	36.5	M16	26	25	28	44	AN 225	070 531 616



90° Flanschverbinder SAE zum Anschweißen

90° weld in SAE flanges

Material: rostfreier Stahl 1.4404

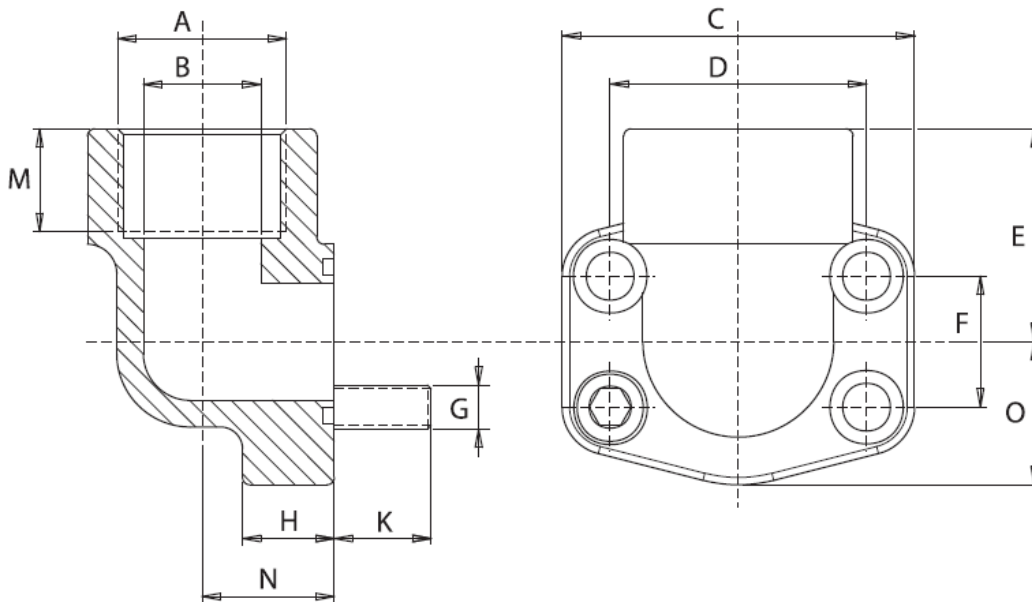

Max. Druck	TYPE	A		B	C	D	E	F	G	H	K	M	O	OR	ATP Artikelnummer
		SAE													
348	RF-F.S. 300.90°-S-M	3/4"	38.5	19	68	47.6	25	22.3	M10	18	15	5	25	AN 214	070 514 608
348	RF-F.S. 302.90°-S-M	1"	44.5	25	72	52.4	28	26.2	M10	19	15	6	27	AN 219	070 514 612
278	RF-F.S. 304.90°-S-M	1 1/4"	53.5	31	82	58.7	34	30.2	M10	22	17	7	34	AN 222	070 514 613
210	RF-F.S. 306.90°-S-M	1 1/2"	62.5	38	95	69.9	43	35.7	M12	25	18	8	39	AN 225	070 514 616
210	RF-F.S. 308.90°-S-M	2"	77	50	105	77.8	50	42.9	M12	25	18	10	44	AN 228	070 514 621

Max. Druck	TYPE	A		B	C	D	E	F	G	H	K	M	O	OR	ATP Artikelnummer
		SAE													
420	RF-F.S. 600.90°-S-M	3/4"	44.5	19	72	50.8	28	23.8	M10	19	15	6	27	AN 214	070 534 608
420	RF-F.S. 602.90°-S-M	1"	53.5	25	82	57.2	34	27.8	M12	24	19	7	34	AN 219	070 534 612
420	RF-F.S. 604.90°-S-M	1 1/4"	62.5	31	95	66.6	43	31.8	M14	25	21	8	39	AN 222	070 534 613
420	RF-F.S. 606.90°-S-M	1 1/2"	77	38	110	79.3	50	36.5	M16	26	25	10	44	AN 225	070 534 616



SAE Verschlussflansch

Blinde flanges SAE

Material: rostfreier Stahl 1.4404

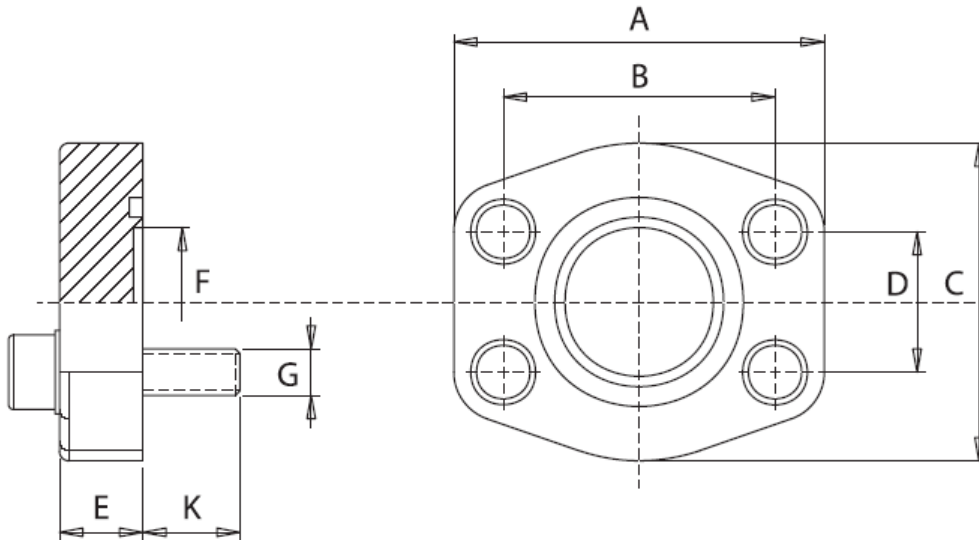

Max. Druck	TYPE	A		B	C	D	E	F	G	K	OR	ATP Artikelnummer
348	RF-C.F.C.S. 100-M	3/4"	66	47.6	49	22.3	18	16	M10	16	AN 214	070 515 208
348	RF-C.F.C.S. 102-M	1"	71	52.4	53	26.2	19	25	M10	16	AN 219	070 515 212
278	RF-C.F.C.S. 104-M	1 1/4"	80	58.7	69	30.2	21	25	M10	18	AN 222	070 515 213
210	RF-C.F.C.S. 106-M	1 1/2"	95	69.9	77	35.7	25	34	M12	19	AN 225	070 515 216
210	RF-C.F.C.S. 108-M	2"	103	77.8	89	42.9	25	43	M12	19	AN 228	070 515 221
175	RF-C.F.C.S. 110-M	2 1/2"	116	89	101	50.8	25	61	M12	19	AN 232	070 515 226
138	RF-C.F.C.S. 112-M	3"	136	106.4	124	61.9	27	60	M16	27	AN 237	070 515 231
35	RF-C.F.C.S. 114-M	3 1/2"	152	120.7	136	69.9	27	73	M16	27	AN 241	070 515 236
35	RF-C.F.C.S. 116-M	4"	162	130.2	146	77.8	27	87	M16	27	AN 245	070 515 241

Max. Druck	TYPE	A		B	C	D	E	F	G	K	OR	ATP Artikelnummer
420	RF-C.F.C.S. 402-M	3/4"	71	50.8	53	23.8	15	20	M10	16	AN 214	070 535 208
420	RF-C.F.C.S. 403-M	1"	80	57.2	66	27.8	17	25	M12	18	AN 219	070 535 212
420	RF-C.F.C.S. 404-M	1 1/4"	94	66.6	77	31.8	18	25	M14	24	AN 222	070 535 213
420	RF-C.F.C.S. 405-M	1 1/2"	103	79.3	89	36.5	20	34	M16	24	AN 225	070 535 216
420	RF-C.F.C.S. 406-M	2"	135	96.8	123	44.5	23	46	M20	31	AN 228	070 535 221



SAE Voll-Flanschverbinder

Uncut SAE split flanges

Material: rostfreier Stahl 1.4404

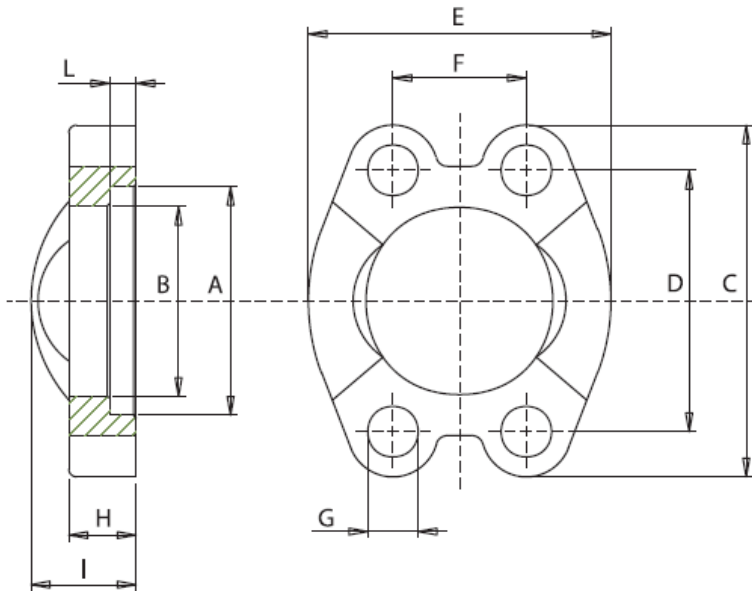

Max. Druck	TYPE	A		B	C	D	E	F	G	H	I	L	ATP Artikelnummer
		1/2"	31	24.3	54	38.1	46	17.4	8.75	13	20	6.2	
210	RF-S.I. 3001-M	1/2"	31	24.3	54	38.1	46	17.4	8.75	13	20	6.2	070 516 006
210	RF-S.I. 3002-M	3/4"	38.9	32.1	65	47.6	52	22.2	10.5	14	22	6.2	070 516 008
210	RF-S.I. 3003-M	1"	45.2	38.5	70	52.4	59	26.2	10.5	16	24	7.5	070 516 012
210	RF-S.I. 3004-M	1 1/4"	51.6	43.7	80	58.7	73	30.2	12	14	22	7.5	070 516 013
210	RF-S.I. 3005-M	1 1/2"	61.1	50.8	94	69.9	83	35.8	13.5	16	25	7.5	070 516 016
210	RF-S.I. 3006-M	2"	72.2	62.7	102	77.8	97	42.8	13.5	16	26	9	070 516 021
175	RF-S.I. 3007-M	2 1/2"	84.9	74.9	115	88.9	109	50.8	13.5	19	38	9	070 516 026
138	RF-S.I. 3008-M	3"	102.4	90.9	135	106.4	131	62.0	17	22	41	9	070 516 031
35	RF-S.I. 3009-M	3 1/2"	115	102.4	152	120.7	140	69.9	17	23	45	10.7	070 516 037

Max. Druck	TYPE	A		B	C	D	E	F	G	H	I	L	ATP Artikelnummer
		1/2"	32.5	24.6	57	40.5	48	18.2	8.75	16	22	7.2	
420	RF-S.I. 6001-M	1/2"	32.5	24.6	57	40.5	48	18.2	8.75	16	22	7.2	070 536 006
420	RF-S.I. 6002-M	3/4"	42	32.5	72	50.8	60	23.8	10.5	19	28	8.3	070 536 008
420	RF-S.I. 6003-M	1"	48.4	38.9	81	57.2	70	27.8	13	24	32	9	070 536 012
420	RF-S.I. 6004-M	1 1/4"	54.8	44.5	96	66.6	78	31.8	15	27	38	9.8	070 536 013
420	RF-S.I. 6005-M	1 1/2"	64.3	51.6	113	79.3	96	36.5	17	30	42	12.1	070 536 016
420	RF-S.I. 6006-M	2"	80.2	67.6	134	96.8	114	44.5	21	37	52	12.1	070 536 021



SAE Halbflansche

SAE split flanges

Material: rostfreier Stahl 1.4404

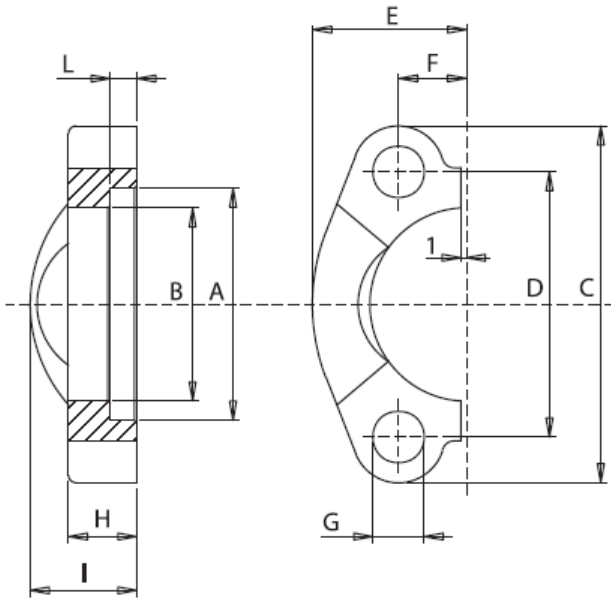

Max. Druck	TYPE	A		B	C	D	E	F	G	H	I	L	ATP Artikelnummer
		1/2"	31	24.3	54	38.1	23	8.7	8.75	13	20	6.2	
210	RF-S.F. 3001-M	1/2"	31	24.3	54	38.1	23	8.7	8.75	13	20	6.2	070 517 006
210	RF-S.F. 3002-M	3/4"	38.9	32.1	65	47.6	26	11.1	10.5	14	22	6.2	070 517 008
210	RF-S.F. 3003-M	1"	45.2	38.5	70	52.4	29.2	13.1	10.5	16	24	7.5	070 517 012
210	RF-S.F. 3004-M	1 1/4"	51.6	43.7	80	58.7	36.3	15.1	12	14	22	7.5	070 517 013
210	RF-S.F. 3005-M	1 1/2"	61.1	50.8	94	69.9	41.1	17.9	13.5	16	25	7.5	070 517 016
210	RF-S.F. 3006-M	2"	72.2	62.7	102	77.8	48.2	21.4	13.5	16	26	9	070 517 021
175	RF-S.F. 3007-M	2 1/2"	84.9	74.9	115	88.9	54	25.4	13.5	19	38	9	070 517 026
138	RF-S.F. 3008-M	3"	102.4	90.9	135	106.4	65.3	31	17	22	41	9	070 517 031
35	RF-S.F. 3009-M	3 1/2"	115	102.4	152	120.7	70	34.85	17	23	45	10.7	070 517 036
35	RF-S.F. 3010-M	4"	127.8	115.1	160	130.2	75	38.9	17	25	48	10.7	070 517 041

Max. Druck	TYPE	A		B	C	D	E	F	G	H	I	L	ATP Artikelnummer
		1/2"	32.5	24.6	57	40.5	24	9.1	8.75	16	22	7.2	
420	RF-S.F. 6001-M	1/2"	32.5	24.6	57	40.5	24	9.1	8.75	16	22	7.2	070 537 006
420	RF-S.F. 6002-M	3/4"	42	32.5	72	50.8	30	11.9	10.5	19	28	8.3	070 537 008
420	RF-S.F. 6003-M	1"	48.4	38.9	81	57.2	35	13.9	13	24	32	9	070 537 012
420	RF-S.F. 6004-M	1 1/4"	54.8	44.5	96	66.6	39	15.9	15	27	38	9.8	070 537 013
420	RF-S.F. 6005-M	1 1/2"	64.3	51.6	113	79.3	48	18.3	17	30	42	12.1	070 537 016
420	RF-S.F. 6006-M	2"	80.2	67.6	134	96.8	57	22.2	21	37	52	12.1	070 537 021



SAE Voll-Flanschverbinder als Gegenflansch mit Gewinde

Uncut SAE split flanges with metric threaded fixing holes

Material: rostfreier Stahl 1.4404

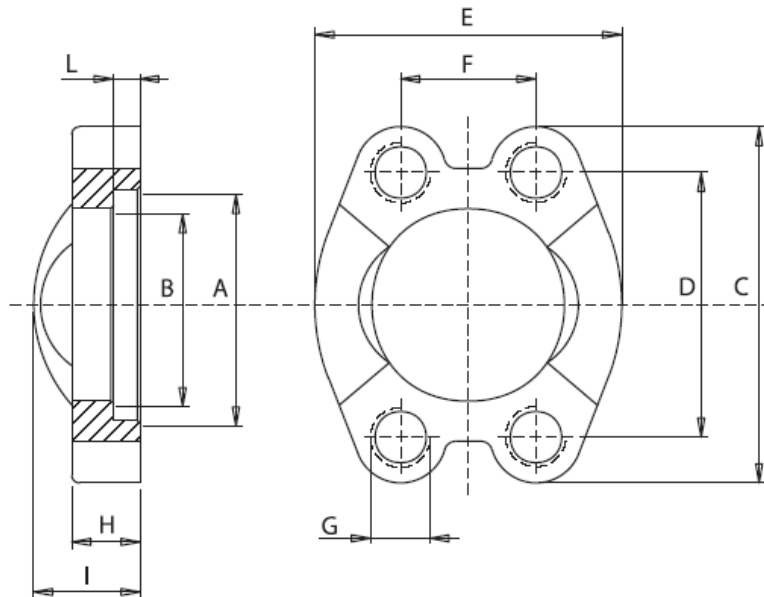

Max. Druck	TYPE	A		B	C	D	E	F	G	H	I	L	ATP Artikelnummer
210	RF-S.I. 3001-F-F	1/2"	31	24.3	54	38.1	46	17.5	M8	13	20	6.2	070 516 106
210	RF-S.I. 3002-F-F	3/4"	38.9	32.1	65	47.6	52	22.3	M10	14	22	6.2	070 516 108
210	RF-S.I. 3003-F-F	1"	45.2	38.5	70	52.4	59	26.2	M10	16	24	7.5	070 516 112
210	RF-S.I. 3004-F-F	1 1/4"	51.6	43.7	80	58.7	73	30.2	M10	14	22	7.5	070 516 113
210	RF-S.I. 3005-F-F	1 1/2"	61.1	50.8	94	69.9	83	35.7	M12	16	25	7.5	070 516 116
210	RF-S.I. 3006-F-F	2"	72.2	62.7	102	77.8	97	42.9	M12	16	26	9	070 516 122
175	RF-S.I. 3007-F-F	2 1/2"	84.9	74.9	115	88.9	109	50.8	M12	19	38	9	070 516 123
138	RF-S.I. 3008-F-F	3"	102.4	90.9	135	106.4	131	61.9	M16	22	41	9	070 516 126
35	RF-S.I. 3009-F-F	3 1/2"	115	102.4	152	120.7	140	69.9	M16	23	45	10.7	070 516 131

Max. Druck	TYPE	A		B	C	D	E	F	G	H	I	L	ATP Artikelnummer
420	RF-S.I. 6001-F-F	1/2"	32.5	24.6	57	40.5	48	18.2	8.75	16	22	7.2	070 536 106
420	RF-S.I. 6002-F-F	3/4"	42	32.5	72	50.8	60	23.8	10.5	19	28	8.3	070 536 108
420	RF-S.I. 6003-F-F	1"	48.4	38.9	81	57.2	70	27.8	13	24	32	9	070 536 112
420	RF-S.I. 6004-F-F	1 1/4"	54.8	44.5	96	66.6	78	31.8	15	27	38	9.8	070 536 113
420	RF-S.I. 6005-F-F	1 1/2"	64.3	51.6	113	79.3	96	36.5	17	30	42	12.1	070 536 116
420	RF-S.I. 6006-F-F	2"	80.2	67.6	134	96.8	114	44.5	21	37	52	12.1	070 536 121



SAE Flansch-Schulter zum Vorschweissen

Weld on SAE adaptors

Material: rostfreier Stahl 1.4404

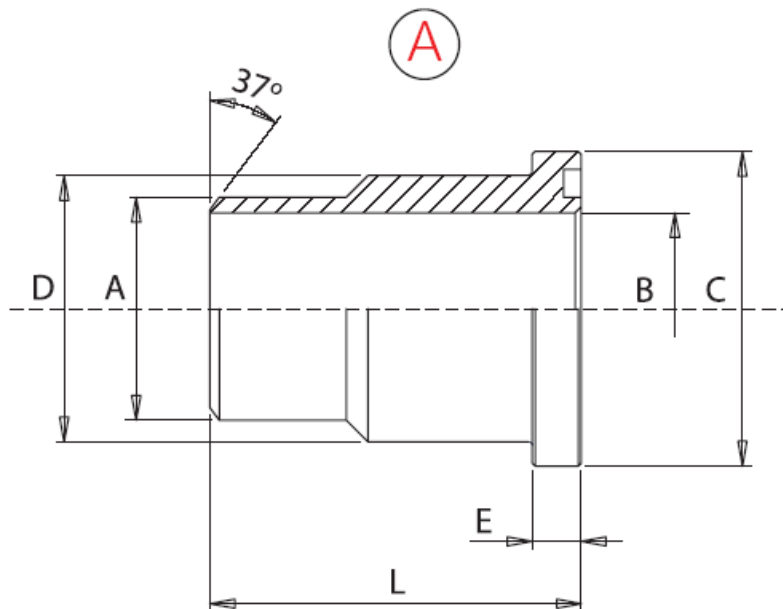

Max. Druck	TYPE	für	A	B	C	D	E	L	OR	ATP Artikelnummer
		Flansch							O-Ring	
210	RF-C. 3001-ST-A	1/2"	16	12	30.2	23.9	6.7	41	AN 210	070 517 906
210	RF-C. 3002-ST-A	3/4"	25	19	38.1	31.7	6.7	50	AN 214	070 517 908
210	RF-C. 3003-ST-A	1"	30	22	44.4	38	8	50	AN 219	070 517 911
210	RF-C. 3004-ST-A	1 1/4"	38	28	50.8	43	8	55	AN 222	070 517 913
210	RF-C. 3005-ST-A	1 1/2"	45	35	60.3	50	8	57	AN 225	070 517 916
210	RF-C. 3006-ST-A	2"	60	45	71.4	62	9.5	57	AN 228	070 517 921
175	RF-C. 3007-ST-A	2 1/2"	70	55	84.1	74	9.5	58	AN 232	070 517 926
138	RF-C. 3008-ST-A	3"	80	68	101.6	90	9.5	60	AN 237	070 517 936
35	RF-C. 3009-ST-A	3 1/2"	100	88	114.3	102	11.2	60	AN 241	
35	RF-C. 3010-ST-A	4"	110	98	127	114	11.2	60	AN 245	

Max. Druck	TYPE	für	A	B	C	D	E	L	OR	ATP Artikelnummer
		Flansch							O-Ring	
420	RF-C. 6001-ST-A	1/2"	17	12	31.8	24	7.7	34	AN 210	070 537 906
420	RF-C. 6002-ST-A	3/4"	25	18	41.3	32	8.7	38	AN 214	070 537 908
420	RF-C. 6003-ST-A	1"	30	22	47.6	38.5	9.5	40	AN 219	070 537 912
420	RF-C. 6004-ST-A	1 1/4"	38	27	54	44	10.3	45	AN 222	070 537 913
420	RF-C. 6005-ST-A	1 1/2"	45	32	63.5	51	12.5	50	AN 225	070 537 916
420	RF-C. 6006-ST-A	2"	60	45	79.4	67	12.5	58	AN 228	070 537 921



O-Ringe O-Rings

Die O-Ringe sind aus NBR in der Härte von 90 Shore
The O-rings are made of NBR (90 shore)

AN-Nr.	Dimensionen	ATP Artikelnummer
AN 210	Ø 18,64 x 3,53	203 540 186
AN 214	Ø 24,99 x 3,53	203 540 250
AN 219	Ø 32,92 x 3,53	203 540 329
AN 222	Ø 37,69 x 3,53	203 540 377
AN 225	Ø 47,22 x 3,53	203 540 472
AN 228	Ø 56,74 x 3,53	203 540 567
AN 232	Ø 69,44 x 3,53	203 540 694
AN 237	Ø 85,32 x 3,53	203 540 853
AN 241	Ø 98,02 x 3,53	203 540 980
AN 245	Ø 110,70 x 3,53	203 541 107

Spezifikation für SAE-Flanschlochbilder Specification for SAE flange ports

SAE Norm	Reihe	Im Katalog
SAE Code 61	Standartreihe	210 bar = 3000 psi
SAE Code 62	Hochdruckreihe	420 bar = 6000 psi

Achtung:
SAE-Flansche > 2" dürfen nicht mit dem Druck von 210 bar resp. 420 bar beaufschlagt werden



Abmasse für SAE-Flanschlochbilder

Dimension for SAE flange ports

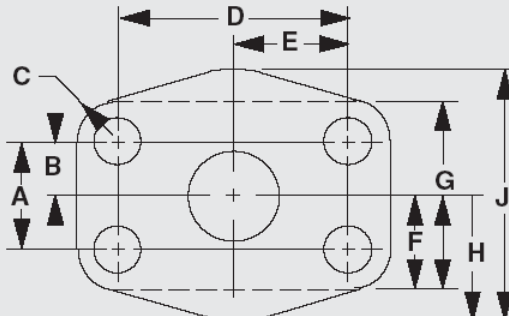
SAE CODE 61			SAE CODE 62	
Nominaler SAE-Flansch	SAE maximal empfohlener Arbeitsdruck*		Nominaler SAE-Flansch	SAE maximal empfohlener Arbeitsdruck*
3/4"	350 bar		1/2"	420 bar
1"	350 bar		3/4"	420 bar
1 1/4"	280 bar		1"	420 bar
1 1/2"	210 bar		1 1/4"	420 bar
2"	210 bar		1 1/2"	420 bar
			2"	420 bar

Standard										Hochdruck									
SAE CODE 61 / 4 Bolzen-Flanschlochbild										SAE CODE 62 / 4 Bolzen-Flanschlochbild									
SAE-Flansch	A	B	C	D	E	F	G	H	J	SAE-Flansch	A	B	C	D	E	F	G	H	J
3/4"	22,2	11,1	8,7	47,6	23,8	20,6	41,3	26,2	52,4	1/2"	18,3	9,1	7,9	40,5	20,2	19,1	38,1	23,8	47,6
1"	26,2	13,1	8,7	52,4	26,2	23,8	47,6	29,4	58,7	3/4"	23,8	11,9	10,3	50,8	25,4	23,8	47,6	30,2	60,3
1 1/4"	30,2	15,1	10,3	58,7	29,4	27	54	36,5	73	1"	27,8	13,9	11,9	57,2	28,6	27	54	34,9	69,9
1 1/2"	35,7	17,9	11,9	69,9	34,9	31,8	63,8	41,3	82,6	1 1/4"	31,8	15,9	14,3	66,7	33,3	30,2	60,3	38,9	77,8
2"	42,9	21,4	11,9	77,8	38,9	38,1	76,2	48,4	96,8	1 1/2"	36,5	18,3	16,7	79,4	39,7	34,9	69,9	47,6	95,3
										2"	44,5	22,2	18,3	96,8	48,4	42,9	85,7	57,2	14,3

Metrisches Befestigungsgewinde					Metrisches Befestigungsgewinde				
SAE-Flansch	Bohrungs-durchmesser	Senkungs-durchmesser	Befestigungs-gewinde	Gewinde-tiefe	SAE-Flansch	Bohrungs-durchmesser	Senkungs-durchmesser	Befestigungs-gewinde	Gewinde-tiefe
3/4"	10,7	17,5	M10x1,5-6H	22,2	1/2"	8,6	14,3	M8x1,25-6H	20,6
1"	10,7	17,5	M10x1,5-6H	22,2	3/4"	10,7	17,5	M10x1,5-6H	23,8
1 1/4"	10,7	17,5	M10x1,5-6H	28,6	1"	12,7	19,1	M12x1,75-6H	27
1 1/2"	12,7	19,1	M12x1,75-6H	27	1 1/4"	15	22,2	M14x2,0-6H	28,4
2"	12,7	19,1	M12x1,75-6H	27	1 1/2"	16,8	25,4	M16x2,0-6H	34,9
					2"	20,6	31,8	M20x2,5-6H	38,1

Referenz: DIN 20066 4-Bolzenflansch

Referenz: DIN 20066 4-Bolzenflansch

Zölliges Befestigungsgewinde					Zölliges Befestigungsgewinde				
SAE-Flansch	Bohrungs-durchmesser	Senkungs-durchmesser	Befestigungs-gewinde	Gewinde-tiefe	SAE-Flansch	Bohrungs-durchmesser	Senkungs-durchmesser	Befestigungs-gewinde	Gewinde-tiefe
3/4"	10,4	15,1	3/8-16 UNC	22,2	1/2"	8,6	12,7	5/16-18UNC	12,7
1"	10,4	15,1	3/8-16 UNC	22,2	3/4"	10,4	15	3/8-16UNC	15
1 1/4"	11,9	17,5	7/16-14UNC	28,6	1"	11,9	17,5	7/16-14UNC	17,5
1 1/2"	13,5	19,8	1/2-13UNC	27	1 1/4"	13,5	19,8	1/2-13UNC	19,8
2"	13,5	19,8	1/2-13UNC	27	1 1/2"	16,8	24,6	5/8-11UNC	24,6
					2"	19,8	29,4	3/4-10UNC	29,4

Referenz: J518 4-Bolzenflansch

Referenz: J518 4-Bolzenflansch



Durchfluss-Nomogramm

Die nachstehende Tabelle erleichtert die Bestimmung des wirtschaftlichen Schlauchquerschnittes für eine bestimmte Durchflussmenge bei idealer Strömungsgeschwindigkeit.

Druckverluste in Schlauchleitungen und Festlegen der Leitungsquerschnitte

Im Interesse eines günstigen Wirkungsgrades ist es bei der Planung von hydraulischen Anlagen wichtig, die **Durchflussquerschnitte** der Leitung so genau wie möglich zu bestimmen.

Zu enge Leitungen haben Druckverluste und übermäßige Erwärmung des Mediums zur Folge, da der gesamte Energieverlust in Wärme umgesetzt wird. Die Lichtweite von Hydraulikschläuchen sollte so gewählt werden, dass die Strömungsgeschwindigkeit je nach der Länge der Leitungen und der Viskosität des Mediums im Bereich von 2 bis 6 m/Sek. liegt. Der Druckverlust verhält sich ungefähr **proportional** zur Durchflussgeschwindigkeit, zur Länge der Schlauchleitung und zur Viskosität des Mediums, wobei sich die einzelnen Werte **addieren**.

Saugleitungen bedingen einen möglichst kleinen Druckverlust. Der Schlauchquerschnitt ist daher so zu wählen, dass die Strömungsgeschwindigkeit, wenn möglich unter 2 m/Sek. liegt.

Flow rate nomogram

The chart shown below facilitates the definition of the most economic hose-width for a certain flow quantity at an ideal flow rate.

Loss of pressure in hose line and determination of the line widths

In the interest of an economic efficiency it is important during the planning of hydraulic plants to determine the line widths as accurately as possible.

Too narrow lines cause loss of pressure and excessive heating of the medium, since the entire loss of energy is transformed into heat. The width of the hydraulic hoses should be chosen so that the flow rate (depending on the length of the lines and viscosity of the medium) lies in the range of 2 to 6 m/sec. The loss of pressure is approximately proportional to the flow rate, to the length of the hose lines and to the viscosity of the medium, whereby all the values are added together.

Suction-lines require a pressure loss that is as low as possible. The hose diameter is therefore to be chosen so that the flow rate lies under 2m/sec. if possible.



Nomogram

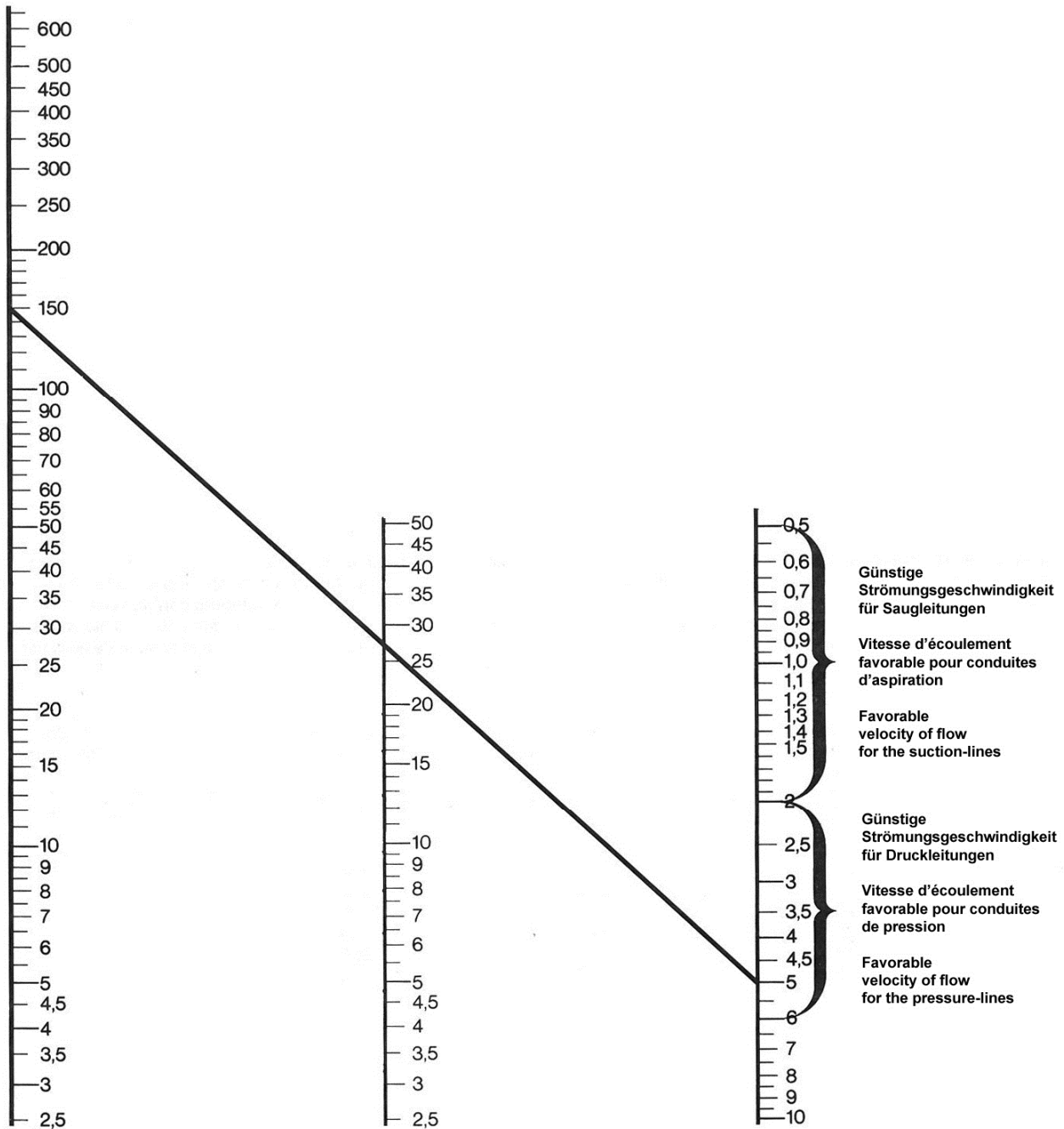

Durchflussmenge l/min. (Q)
Volume du débit l/min. (Q)
Flow rate l/min. (Q)

Schlauch-Innendurchmesse in mm (d)
Diamètre intérieur du tuyau en mm (d)
Inner diameter of hose in mm (d)

Beispiel

Gesucht ist der Leitungsdurchmesser (d) für eine gegebene Durchflussmenge 150 l/min. (Q) bei einer Strömungsgeschwindigkeit von 5 m/Sek. (v)

Ergebnis

d=25 (DN 25)

Exemple

Déterminez le diamètre de la tuyauterie (d), partant d'une débit de 150 l/min (Q), et d'une vitesse de passage de 5 m/sec. (v).

Résultat

d=25 (DN25)

Example

Find the line diameter (d) for a flow quantity of 150 l/min. (Q) at a flow rate of 5m/sec. (v)

Result

d=25 (DN 25)



Chemische Material Zusammensetzung

Chemical material composition

(Schmelzenanalyse) in Gewichtsprozent [%]

Typ	C	Si	Mn	P	S	N
X2CrNiMo 17-12-2	≤ 0.03	≤ 1.0	≤ 2.0	≤ 0.045	≤ 0.015	≤ 0.11



INDEX

ATP-Art.Nr.	Seite	Bezeichnung	Seite
070 511 2xx.....	2, 3	RF-C. 4xx-GAS-F-F-M	7
070 511 3xx.....	4	RF-C. 4xx-ST-F-F-M	9
070 511 6xx.....	10	RF-C. 300x-ST-A.....	16
		RF-C. 600x-ST-A.....	16
070 513 2xx.....	5	RF-C. xxx-GAS-F-F-M.....	7
070 513 8xx.....	8	RF-C. xxx-ST-F-F-M.....	9
070 514 2xx.....	6	RF-C.F.C.S. 1xx-M.....	12
070 514 6xx.....	11	RF-C.F.C.S. 40x-M.....	12
070 514 8xx.....	9	RF-C.F.S. 4xx-GAS-M.....	2
070 515 2xx.....	12	RF-C.F.S. 4xx-GAS-U	3
070 516 0xx.....	13	RF-C.F.S. 4xx-NPT-M.....	4
070 516 1xx.....	15	RF-C.F.S. 4xx-S-M.....	5
070 517 0xx.....	14	RF-C.F.S. 4xx-ST-M.....	6
070 517 9xx.....	16	RF-C.F.S. xxx-GAS-M.....	2
070 531 2xx.....	3	RF-C.F.S. xxx-GAS-U	3
070 531 3xx.....	4	RF-C.F.S. xxx-NPT-M	4
070 531 6xx.....	10	RF-C.F.S. xxx-S-M.....	5
		RF-C.F.S. xxx-ST-M.....	6
070 533 2xx.....	5	RF-F.S. 30x.90°-S-M.....	11
070 533 8xx.....	8	RF-F.S. 3xx.90°-GAS-M.....	10
070 534 2xx.....	6	RF-F.S. 60x. 90° S-M.....	11
070 534 6xx.....	11	RF-F.S. 6xx. 90°-GAS-M.....	10
070 534 8xx.....	9	RF-M-C. 4xx-S-F-F.....	8
070 535 2xx.....	12	RF-M-C. xxx-S-F-F.....	8
070 536 0xx.....	13	RF-S.F. 600x-M.....	14
070 536 1xx.....	15	RF-S.I. 300x-F-F	15
070 537 0xx.....	14	RF-S.I. 300x-M	13
070 537 9xx.....	16	RF-S.I. 600x-F-F	15
		RF-S.I. 600x-M.....	13
		RF-S.F. 30xx-M.....	14